

### Features

- Beam-Lead Device
- No Wirebonds Required
- Rugged Silicon-Glass Construction
- Silicon Nitride Passivation
- Polymer Scratch and Impact Protection
- Low Parasitic Capacitance and Inductance
- Ultra Low Capacitance < 40 fF
- Excellent RC Product < 0.10 pS
- High Switching Cutoff Frequency > 110 GHz
- 110 Nanosecond Minority Carrier Lifetime
- Driven by Standard +5V TTL PIN Diode Driver

### Description

This device is a Silicon-Glass Beam-Lead PIN diode fabricated with M/A-COM's patented HMIC™ process. This device features one silicon pedestal embedded in a low loss, low dispersion glass which supports the beam-leads. The diode is formed on the top of the pedestal, and airbridges connect the diode to the beam-leads. The topside is fully encapsulated with silicon nitride and has an additional polymer layer for scratch and impact protection. These protective coatings prevent damage to the junction and the air-bridges during handling and assembly.

The diodes themselves exhibit low series resistance, low capacitance, and extremely fast switching speed.

### Applications

The ultra low capacitance of this device allows use through W-band (110 GHz) applications. The low RC product and low profile of the PIN diodes makes it ideal for use in microwave and millimeter wave switch designs, where lower insertion loss and higher isolation are required. The + 10 mA ( low loss state ) and the 0v ( isolation state ) bias of the diodes allows the use a simple + 5V TTL gate driver. These diodes are used as switching arrays on radar systems, high-speed ECM circuits, optical switching networks, instrumentation, and other wideband multi-throw switch assemblies.

### Absolute Maximum Ratings<sup>1</sup>

@ T<sub>A</sub> = +25°C ( Unless otherwise specified )

Parameter	Absolute Maximum
Forward Current	100 mA
Reverse Voltage	90 V
Operating Temperature	-55 °C to +125 °C
Storage Temperature	-55 °C to +150 °C
Junction Temperature	+ 175 °C
RF C.W. Incident Power	30 dBm C.W.
RF & DC Dissipated Power	150 mW
Mounting Temperature	+235°C for 10 seconds

1. Exceeding these limits may cause permanent damage.

### Case Style ODS-1302

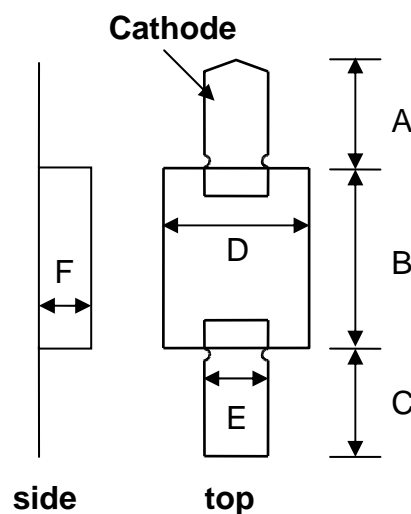

Dimension	Mils	mm
A	9.3 +/- 2.0	0.24 +/- 0.05
B	15.3 +/- 2.0	0.39 +/- 0.05
C	9.3 +/- 2.0	0.24 +/- 0.05
D	12.6 +/- 2.0	0.32 +/- 0.05
E	5.5 +/- 2.0	0.14 +/- 0.05
F	5.0 +/- 1.0	0.13 +/- 0.03

### Electrical Specifications at +25°C

Symbol	Conditions	Units	Typ	Max
$C_T$	0V, 1MHz <sup>2</sup>	pF	0.048	
$C_T$	-3V, 1MHz <sup>2</sup>	pF	0.039	
$C_T$	-10V, 1MHz <sup>2</sup>	pF	0.033	<b>0.040</b>
$C_T$	-40V, 1MHz <sup>2</sup>	pF	0.030	<b>0.040</b>
$C_T$	0V, 100MHz <sup>2,4</sup>	pF	0.043	
$C_T$	-3V, 100MHz <sup>2,4</sup>	pF	0.033	
$C_T$	-10V, 100MHz <sup>2,4</sup>	pF	0.031	
$C_T$	-40V, 100MHz <sup>2,4</sup>	pF	0.027	
$C_T$	0V, 1GHz <sup>2,4</sup>	pF	0.039	
$C_T$	-3V, 1GHz <sup>2,4</sup>	pF	0.032	
$C_T$	-10V, 1GHz <sup>2,4</sup>	pF	0.029	
$C_T$	-40V, 1GHz <sup>2,4</sup>	pF	0.026	
$R_S$	10mA, 100 MHz <sup>3,4</sup>	$\Omega$	3.8	
$R_S$	20mA, 100 MHz <sup>3,4</sup>	$\Omega$	3.0	
$R_S$	10mA, 1GHz <sup>3,4</sup>	$\Omega$	3.5	
$R_S$	20mA, 1GHz <sup>3,4</sup>	$\Omega$	2.8	
$V_F$	20mA	V	0.917	<b>1.1</b>
$V_R$	-10 $\mu$ A	V	110	
$I_R$	-40 V	nA	1.0	
$I_R$	-90 V	$\mu$ A	-	<b>10.0</b>
TL	+10mA / -6mA	ns	110	

Notes:

- Total capacitance,  $C_T$ , is equivalent to the sum of Junction Capacitance,  $C_j$ , and Parasitic Capacitance,  $C_{par}$ .
- Series resistance  $R_S$  is equivalent to the total diode resistance :  
 $R_S = R_j$  ( Junction Resistance) +  $R_c$  ( Ohmic Resistance)
- $R_S$  and  $C_T$  are measured on an HP4291A Impedance Analyzer with die mounted in an ODS-186 package with conductive silver epoxy.

### Die Handling

All semiconductor chips should be handled with care to avoid damage or contamination from perspiration and skin oils. The use of plastic tipped tweezers or vacuum pickups is strongly recommended for individual components. Bulk handling should insure that abrasion and mechanical shock are minimized.

### Die Bonding

These devices were designed to be inserted onto hard or soft substrates. Recommended methods of attachment include thermocompression bonding, parallel-gap welding, and electrically conductive silver epoxy.

See Application Note M541, “Bonding and Handling Procedures for Chip Diode Devices” for More Detailed Assembly Instructions.

### Typical Performance Curves @ +25°C

#### Total Capacitance $C_t$ vs V

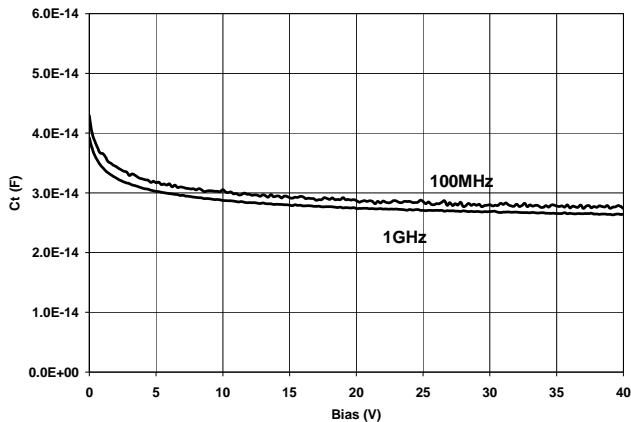

#### Total Capacitance $C_t$ vs Freq

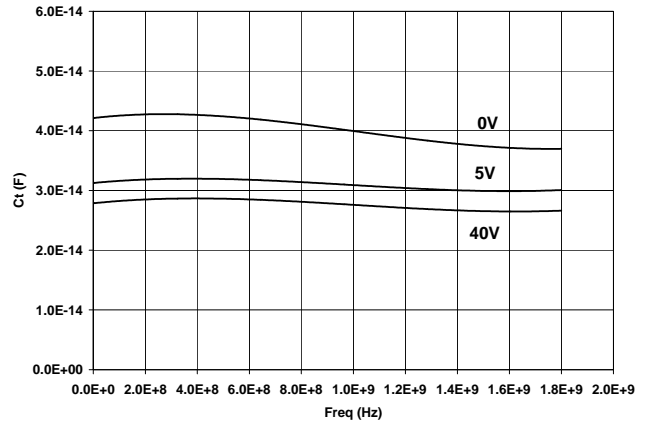

#### Parallel Resistance $R_p$ vs V

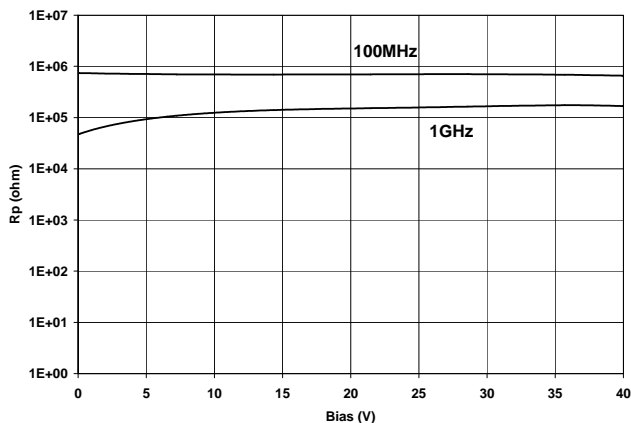

#### Series Resistance $R_s$ vs F

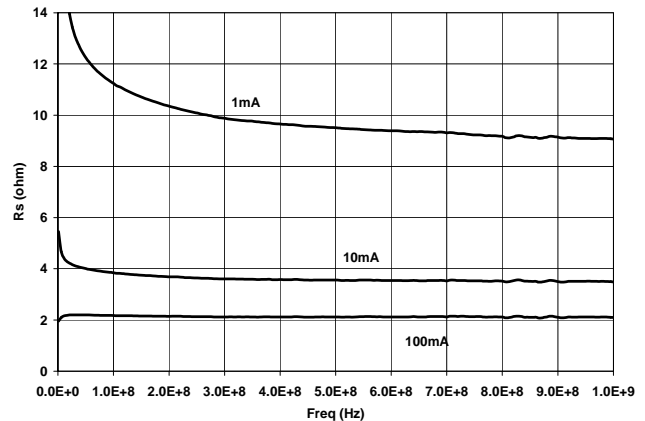

#### Series Resistance $R_s$ vs I

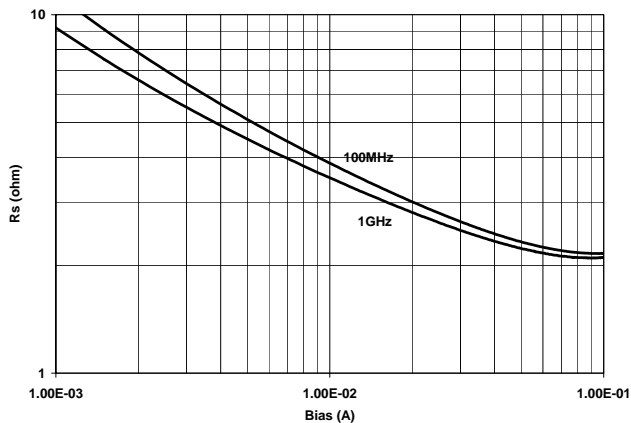

#### Series Inductance $L_s$ vs Freq

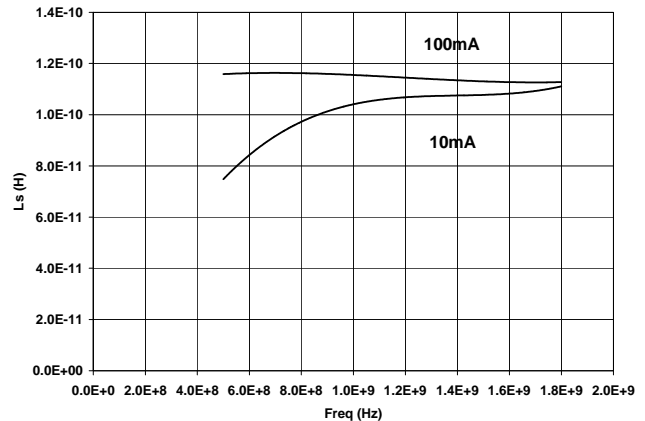

**ADVANCED:** Data Sheets contain information regarding a product M/A-COM Technology Solutions is considering for development. Performance is based on target specifications, simulated results, and/or prototype measurements. Commitment to develop is not guaranteed.

**PRELIMINARY:** Data Sheets contain information regarding a product M/A-COM Technology Solutions has under development. Performance is based on engineering tests. Specifications are typical. Mechanical outline has been fixed. Engineering samples and/or test data may be available. Commitment to produce in volume is not guaranteed.

• **North America** Tel: 800.366.2266 • **Europe** Tel: +353.21.244.6400  
 • **India** Tel: +91.80.43537383 • **China** Tel: +86.21.2407.1588  
 Visit [www.macomtech.com](http://www.macomtech.com) for additional data sheets and product information.

M/A-COM Technology Solutions Inc. and its affiliates reserve the right to make changes to the product(s) or information contained herein without notice.

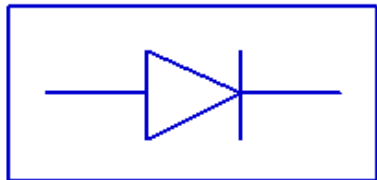

## MA4PBL027 SPICE Model

PinDiodeModel

NLPINM1

Is=1.0E-14 A

Vi=0.0 V

Un= 900 cm<sup>2</sup>/V-sec

Wi= 14 um

Rr= 100 K Ohms

Cjmin= 0.03 pF

Tau= 110 nsec

Rs(l)= Rc + Rj(l) = 0.05 Ohm + Rj(l)

Cj0= 0.04 pF

Vj= 0.7 V

M= 0.5

Fc= 0.5

Imax= 1.1E+5 A/m<sup>2</sup>

Kf=0.0

Af=1.0

wBv= 90 V

wPmax= 150 mW

Ffe= 1.0

AllParams=

## MA4PBL027 Microwave Model

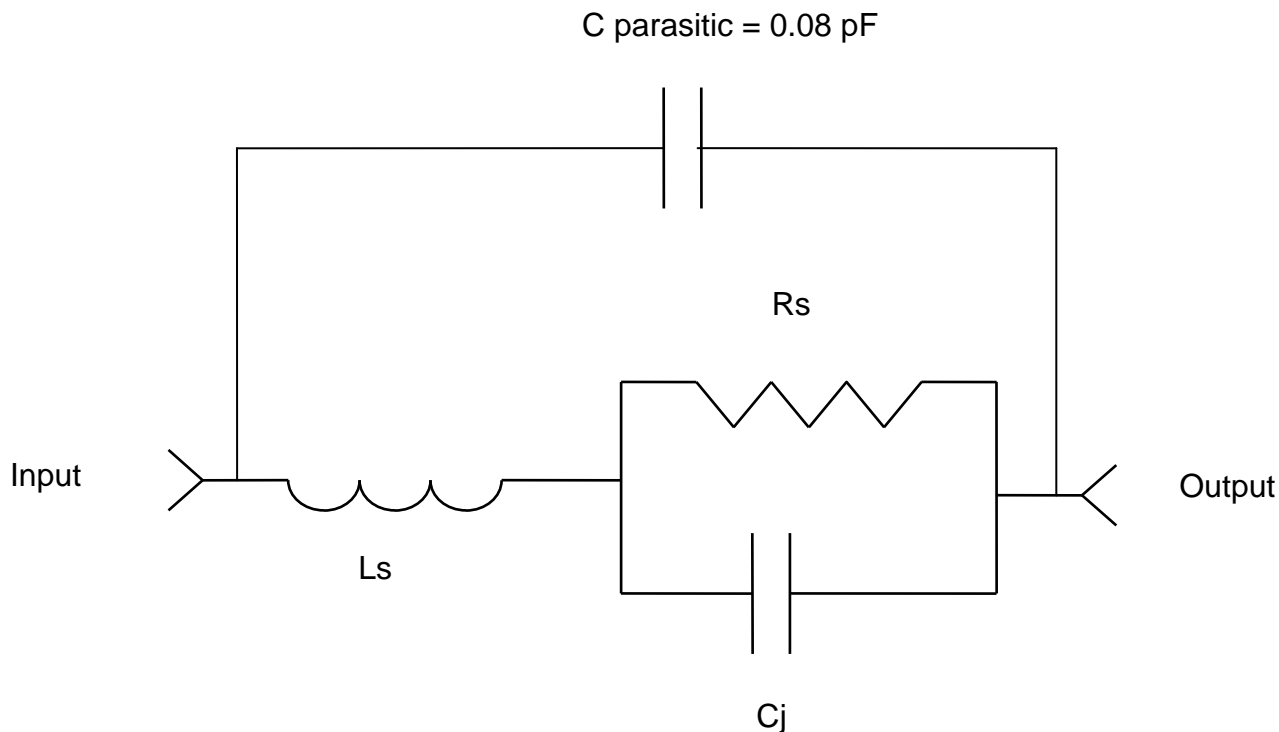

### Notes :

$$C_T(V) = C_j(V) + C_{\text{parasitic}} \text{ ( Reverse Bias State )}$$

$$R_s(I) = R_j(I) + R_c \text{ ( Forward Bias State )}$$

$$R_s(V) = R_j(V) = R_p(V) \text{ ( Reverse Bias State )}$$

Компания «Life Electronics» занимается поставками электронных компонентов импортного и отечественного производства от производителей и со складов крупных дистрибьюторов Европы, Америки и Азии.

С конца 2013 года компания активно расширяет линейку поставок компонентов по направлению коаксиальный кабель, кварцевые генераторы и конденсаторы (керамические, пленочные, электролитические), за счёт заключения дистрибьюторских договоров

Мы предлагаем:

- Конкуренспособные цены и скидки постоянным клиентам.
- Специальные условия для постоянных клиентов.
- Подбор аналогов.
- Поставку компонентов в любых объемах, удовлетворяющих вашим потребностям.
- Приемлемые сроки поставки, возможна ускоренная поставка.
- Доставку товара в любую точку России и стран СНГ.
- Комплексную поставку.
- Работу по проектам и поставку образцов.
- Формирование склада под заказчика.
- Сертификаты соответствия на поставляемую продукцию (по желанию клиента).
- Тестирование поставляемой продукции.
- Поставку компонентов, требующих военную и космическую приемку.
- Входной контроль качества.
- Наличие сертификата ISO.

В составе нашей компании организован Конструкторский отдел, призванный помогать разработчикам, и инженерам.

Конструкторский отдел помогает осуществить:

- Регистрацию проекта у производителя компонентов.
- Техническую поддержку проекта.
- Защиту от снятия компонента с производства.
- Оценку стоимости проекта по компонентам.
- Изготовление тестовой платы монтаж и пусконаладочные работы.



Тел: +7 (812) 336 43 04 (многоканальный)

Email: [org@lifeelectronics.ru](mailto:org@lifeelectronics.ru)