

DATA SHEET

Part No.	AN44075A
Package Code No.	HSOP034-P-0300A

Contents

■ Overview	3
■ Features	3
■ Applications	3
■ Package	3
■ Type	3
■ Application Circuit Example (Block Diagram)	4
■ Pin Descriptions	5
■ Absolute Maximum Ratings	6
■ Operating Supply Voltage Range	6
■ Electrical Characteristics	7
■ Electrical Characteristics (Reference values for design)	9
■ Technical Data	10
• Control mode (truth table)	10

AN44075A

Driver IC for DC motor

■ Overview

AN44075A is a one channel H-bridge driver IC. 1-ch. DC motor can be controlled by a single driver IC.

■ Features

- Built-in thermal protection and low voltage detection circuit
- Built-in over current protection (when external resistance is added to pin 7 and pin 8.)
- Built-in 5 V power supply

■ Applications

- IC for DC motor drives

■ Package

- 34 pin plastic small outline package with back heat sink (SOP type)

■ Type

- Bi-CDMOS IC

■ Application Circuit Example (Block Diagram)

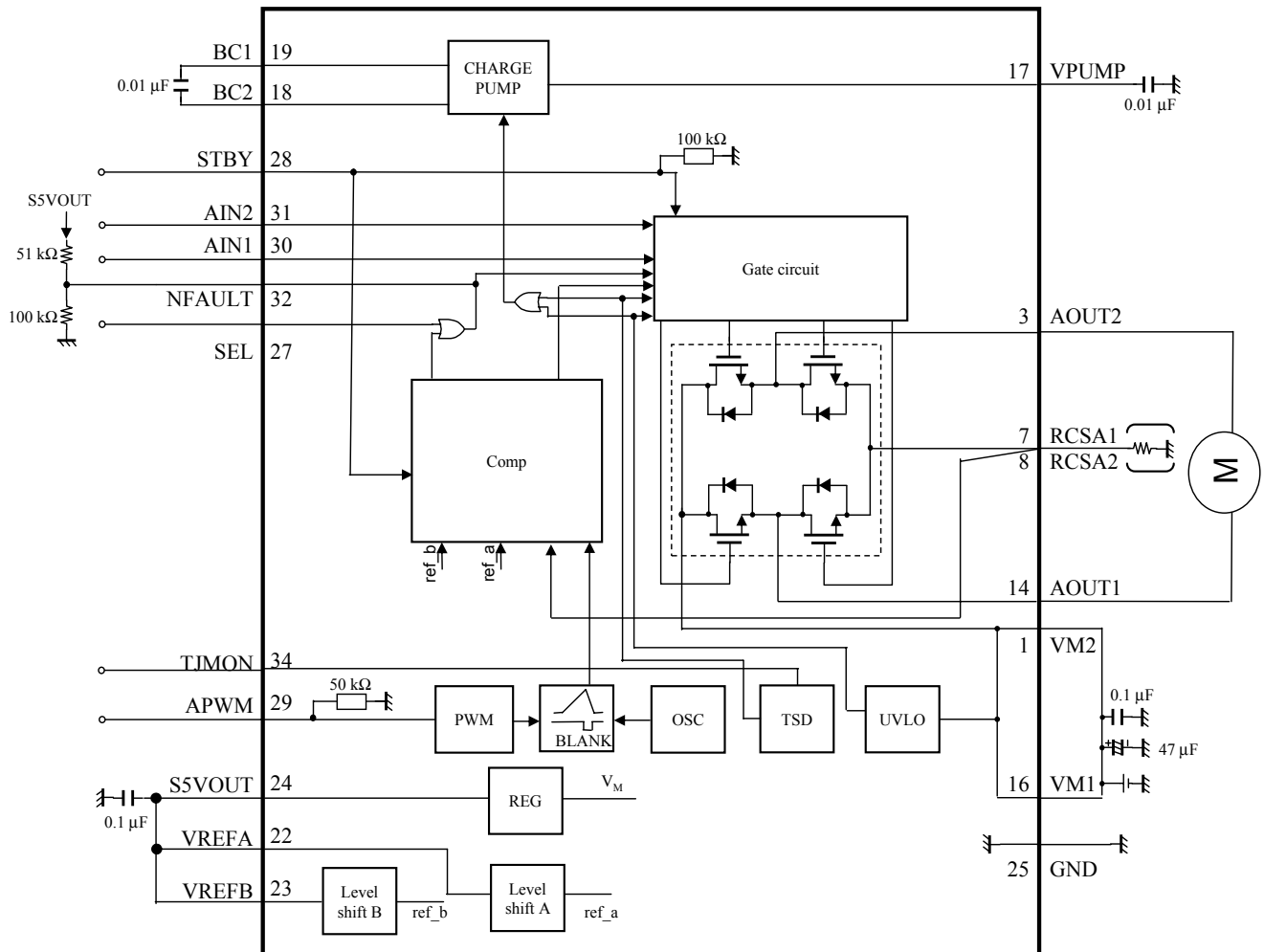

Note) This application circuit is shown as an example but does not guarantee the design for mass production set.

■ Pin Descriptions

Pin No.	Pin name	Type	Description
1	VM2	Power supply	Motor power supply 2
2	N.C.	—	not used
3	AOUT2	Output	Motor drive output 2
4	N.C.	—	not used
5	N.C.	—	not used
6	N.C.	—	not used
7	RCSA1	Input / Output	Current detection 1
8	RCSA2	Input / Output	Current detection 2
9	GND	Ground	Die pad ground
10	N.C.	—	not used
11	N.C.	—	not used
12	N.C.	—	not used
13	N.C.	—	not used
14	AOUT1	Output	Motor drive output 1
15	N.C.	—	not used
16	VM1	Power supply	Motor power supply 1
17	VPUMP	Output	Charge pump circuit output
18	BC2	Output	Charge pump capacitor connection 2
19	BC1	Output	Charge pump capacitor connection 1
20	N.C.	—	not used
21	N.C.	—	not used
22	VREFA	Input	Peak current setting input
23	VREFB	Input	Load short threshold input
24	S5VOUT	Output	Internal reference voltage (5 V output)
25	GND	Ground	Signal ground
26	GND	Ground	Die pad ground
27	SEL	Input	Test mode input
28	STBY	Input	Standby input
29	APWM	Input	PWM input
30	AIN1	Input	Forward-reverse input
31	AIN2	Input	Brake mode input
32	NFAULT	Output	Abnormal detection output
33	N.C.	—	not used
34	TJMON	Output	VBE monitor

■ Absolute Maximum Ratings

A No.	Parameter	Symbol	Rating	Unit	Note
1	Supply voltage (pin 1, pin 16)	V_M	37	V	*1
5	Output pin voltage (pin 3, pin 14)	V_{OUT}	37	V	*2
6	Motor drive current (pin 3, pin 14)	I_{OUT}	± 3.0	A	*2, *3
7	Flywheel diode current (pin 3, pin 14)	I_f	3.0	A	*2, *3
2	Power dissipation	P_D	0.466	W	*4
3	Operating ambient temperature	T_{opr}	-20 to +70	°C	*5
4	Storage temperature	T_{stg}	-55 to +150	°C	*5

Note) *1: The range under absolute maximum ratings, power dissipation.

*2: Do not apply external currents to any pin specially mentioned. For circuit currents, (+) denotes current flowing into the IC and (-) denotes current flowing out of the IC.

*3: Rating when cooling fin on the back side of the IC is connected to the GND pattern of the glass epoxy 4-layer board.
(GND area: 2nd-layer or 3rd-layer: more than 1 500 mm²)

In case of no cooling fin on the back side of the IC, rating current is 1.5 A on the glass epoxy 2-layer board.

*4: Power dissipation shows the value of only package at $T_a = 70^\circ\text{C}$.

When using this IC, refer to the $\bullet P_D - T_a$ diagram in the ■ Technical Data and use under the condition not exceeding the allowable value.

*5: Expect for the storage temperature and operating ambient temperature, all ratings are for $T_a = 25^\circ\text{C}$.

■ Operating Supply Voltage Range

Parameter	Symbol	Range	Unit	Note
Supply voltage range	V_M	10.0 to 35.0	V	—

Note) The values under the condition not exceeding the above absolute maximum ratings and the power dissipation.

■ Electrical Characteristics at $V_{CC} = 24\text{ V}$

Note) $T_a = 25^\circ\text{C} \pm 2^\circ\text{C}$ unless otherwise specified.

B No.	Parameter	Symbol	Conditions	Limits			Unit	Note
				Min	Typ	Max		
Output drivers								
1	High-level output saturation voltage	V_{OH}	$I_{SA1} = I_{SA2} = -1\text{ A}$	V_M -0.47	V_M -0.36	—	V	—
2	Low-level output saturation voltage	V_{OL}	$I_{SA1} = I_{SA2} = 1\text{ A}$	—	0.50	0.65	V	—
3	Flywheel diode forward voltage	V_{DI}	$I_{DI} = \pm 1\text{ A}$	0.5	1.0	1.5	V	—
4	Output leakage current	I_{LEAK}	$V_M = 37\text{ V}, V_{SRCS} = 0\text{ V}$	—	10	20	μA	—
Power supply								
5	Supply current 1 (sleep)	I_{M1}	$V_{STBY} = 0\text{ V}$	—	65	105	μA	—
6	Supply current 2 (with circuit turned on)	I_{M2}	$V_{STBY} = 5\text{ V}$	—	7.3	12	mA	—
7	Reference voltage	V_{SSVOUT}	$I_{SSVOUT} = -2.5\text{ mA}$	4.5	5.0	5.5	V	—
8	Output impedance	Z_{SSVOUT}	$\Delta I_{SSVOUT} = -5\text{ mA}$	—	18	27	Ω	—
IN input								
9	High-level IN input voltage	V_{INH}	—	2.1	—	5	V	—
10	Low-level IN input voltage	V_{INL}	—	0	—	0.6	V	—
11	High-level IN input current	I_{INH}	$V_{AIN1} = V_{AIN2} = 5\text{ V}$	-10	—	10	μA	—
12	Low-level IN input current	I_{INL}	$V_{AIN1} = V_{AIN2} = 0\text{ V}$	-10	—	10	μA	—
Standby input								
13	High-level STBY input voltage	V_{STBYH}	—	2.1	—	5	V	—
14	Low-level STBY input voltage	V_{STBYL}	—	0	—	0.6	V	—
15	High-level STBY input current	I_{STBYH}	$V_{STBY} = 5\text{ V}$	30	—	80	μA	—
16	Low-level STBY input current	I_{STBYL}	$V_{STBY} = 0\text{ V}$	-10	—	10	μA	—
PWM input								
17	High-level PWM input voltage	V_{PWMH}	—	2.1	—	5	V	—
18	Low-level PWM input voltage	V_{PWML}	—	0	—	0.6	V	—
19	High-level PWM input current	I_{PWMH}	$V_{APWM} = 5\text{ V}$	60	—	150	μA	—
20	Low-level PWM input current	I_{PWML}	$V_{APWM} = 0\text{ V}$	-10	—	10	μA	—
21	PWM input max. frequency	f_{PWM}	—	—	—	200	kHz	—
22	Input min. pulse width	t_w	—	2	—	—	μs	—

■ Electrical Characteristics at $V_{CC} = 24\text{ V}$ (continued)

Note) $T_a = 25^\circ\text{C} \pm 2^\circ\text{C}$ unless otherwise specified.

B No.	Parameter	Symbol	Conditions	Limits			Unit	Note
				Min	Typ	Max		
Peak current detection / over current protection								
23	Input bias current	I_{REF}	$V_{REFA} = V_{REFB} = 5\text{ V}$	83	100	125	μA	—
24	PWM frequency	f_{PWM}	$V_{REFA} = 0\text{ V}, V_{REFB} = 5\text{ V}$	17	26	35	kHz	—
25	Pulse blanking time	T_B	$V_{REFA} = 0\text{ V}, V_{REFB} = 5\text{ V}$	1.5	2.5	4.5	μs	—
26	Comp threshold 1	V_{TH1}	$V_{REFA} = V_{REFB} = 5\text{ V}$	480	500	520	mV	—
27	Comp threshold 2	V_{TH2}	$V_{REFA} = 5.5\text{ V}, V_{REFB} = 2.5\text{ V}$	475	500	525	mV	—
28	NFAULT output voltage	V_{NFLT}	$I_{NFLT} = 1\text{ mA}$	—	—	0.4	V	—

■ Electrical Characteristics (Reference values for design) at $V_{CC} = 9\text{ V}$

Note) $T_a = 25^\circ\text{C} \pm 2^\circ\text{C}$ unless otherwise specified.

The characteristics listed below are reference values for design of the IC and are not guaranteed by inspection.

If a problem does occur related to these characteristics, Panasonic will respond in good faith to user concerns.

B No.	Parameter	Symbol	Conditions	Limits			Unit	Note
				Min	Typ	Max		
Output drivers								
29	Output slew rate 1	VT_r	Rising edge	—	270	—	V/ μs	—
30	Output slew rate 2	VT_f	Falling edge	—	330	—	V/ μs	—
31	Dead time	T_D	—	—	0.45	—	μs	—
Thermal protection								
32	Thermal protection operating temperature	TSD_{on}	—	—	150	—	$^\circ\text{C}$	—
33	Thermal protection hysteresis width	ΔTSD	—	—	40	—	$^\circ\text{C}$	—
Low voltage protection								
34	Protection operating voltage	UVLO1	—	—	8.0	—	V	—
35	Protection release voltage	UVLO2	—	—	8.6	—	V	—

■ Technical Data

- Control mode (truth table)

INPUT				OUTPUT		
STBY	AIN1	AIN2	APWM	AOUT1	AOUT2	Mode
"H"	—	"H"	"L"	"H"	"H"	Short brake
	"L"	—	"H"	"L"	"H"	Forward
	"H"	—	"H"	"H"	"L"	Reverse
	—	"L"	"L"	OFF	OFF	Stop
"L"	—	—	—	OFF	OFF	Standby

INPUT	OUTPUT
SEL	Mode
"H"	Short detect off
"L"	Short detect on

Request for your special attention and precautions in using the technical information and semiconductors described in this book

- (1) If any of the products or technical information described in this book is to be exported or provided to non-residents, the laws and regulations of the exporting country, especially, those with regard to security export control, must be observed.
- (2) The technical information described in this book is intended only to show the main characteristics and application circuit examples of the products. No license is granted in and to any intellectual property right or other right owned by Panasonic Corporation or any other company. Therefore, no responsibility is assumed by our company as to the infringement upon any such right owned by any other company which may arise as a result of the use of technical information described in this book.
- (3) The products described in this book are intended to be used for standard applications or general electronic equipment (such as office equipment, communications equipment, measuring instruments and household appliances).
Consult our sales staff in advance for information on the following applications:
 - Special applications (such as for airplanes, aerospace, automobiles, traffic control equipment, combustion equipment, life support systems and safety devices) in which exceptional quality and reliability are required, or if the failure or malfunction of the products may directly jeopardize life or harm the human body.
 - Any applications other than the standard applications intended.
- (4) The products and product specifications described in this book are subject to change without notice for modification and/or improvement. At the final stage of your design, purchasing, or use of the products, therefore, ask for the most up-to-date Product Standards in advance to make sure that the latest specifications satisfy your requirements.
- (5) When designing your equipment, comply with the range of absolute maximum rating and the guaranteed operating conditions (operating power supply voltage and operating environment etc.). Especially, please be careful not to exceed the range of absolute maximum rating on the transient state, such as power-on, power-off and mode-switching. Otherwise, we will not be liable for any defect which may arise later in your equipment.
 - Even when the products are used within the guaranteed values, take into the consideration of incidence of break down and failure mode, possible to occur to semiconductor products. Measures on the systems such as redundant design, arresting the spread of fire or preventing glitch are recommended in order to prevent physical injury, fire, social damages, for example, by using the products.
- (6) Comply with the instructions for use in order to prevent breakdown and characteristics change due to external factors (ESD, EOS, thermal stress and mechanical stress) at the time of handling, mounting or at customer's process. When using products for which damp-proof packing is required, satisfy the conditions, such as shelf life and the elapsed time since first opening the packages.
- (7) This book may be not reprinted or reproduced whether wholly or partially, without the prior written permission of our company.

Компания «Life Electronics» занимается поставками электронных компонентов импортного и отечественного производства от производителей и со складов крупных дистрибьюторов Европы, Америки и Азии.

С конца 2013 года компания активно расширяет линейку поставок компонентов по направлению коаксиальный кабель, кварцевые генераторы и конденсаторы (керамические, пленочные, электролитические), за счёт заключения дистрибьюторских договоров

Мы предлагаем:

- Конкурентоспособные цены и скидки постоянным клиентам.
- Специальные условия для постоянных клиентов.
- Подбор аналогов.
- Поставку компонентов в любых объемах, удовлетворяющих вашим потребностям.
- Приемлемые сроки поставки, возможна ускоренная поставка.
- Доставку товара в любую точку России и стран СНГ.
- Комплексную поставку.
- Работу по проектам и поставку образцов.
- Формирование склада под заказчика.
- Сертификаты соответствия на поставляемую продукцию (по желанию клиента).
- Тестирование поставляемой продукции.
- Поставку компонентов, требующих военную и космическую приемку.
- Входной контроль качества.
- Наличие сертификата ISO.

В составе нашей компании организован Конструкторский отдел, призванный помогать разработчикам, и инженерам.

Конструкторский отдел помогает осуществить:

- Регистрацию проекта у производителя компонентов.
- Техническую поддержку проекта.
- Защиту от снятия компонента с производства.
- Оценку стоимости проекта по компонентам.
- Изготовление тестовой платы монтаж и пусконаладочные работы.



Тел: +7 (812) 336 43 04 (многоканальный)

Email: org@lifeelectronics.ru