

**PLEASE CHECK WWW.MOLEX.COM FOR LATEST PART INFORMATION**

**Part Number:** [0751341000](#)  
**Status:** **Active**  
**Overview:** [dms59](#)  
**Description:** 1.27mm (.050") Pitch DMS-59® Receptacle, Shielded, Right Angle

**Documents:**

[3D Model](#) [Product Specification PS-75134-001 \(PDF\)](#)  
[Drawing \(PDF\)](#) [RoHS Certificate of Compliance \(PDF\)](#)

**General**

Product Family	I/O Connectors
Series	75134
Application	Wire-to-Board
Component Type	Receptacle
Overview	<a href="#">dms59</a>
Product Name	DMS59®
Type	N/A

**Physical**

Circuits (Loaded)	59
Circuits (maximum)	59
Color - Resin	Black
Lock to Mating Part	Yes
Material - Metal	Beryllium Copper
Material - Plating Mating	Gold
Material - Plating Termination	Tin
Material - Resin	High Temperature Thermoplastic
Orientation	Right Angle
PC Tail Length (in)	0.092 In
PC Tail Length (mm)	2.34 mm
PCB Retention	Yes
PCB Thickness Recommended (in)	0.062 In
PCB Thickness Recommended (mm)	1.60 mm
Packaging Type	Tube
Panel Mount	Yes
Pitch - Mating Interface (in)	0.050 In
Pitch - Mating Interface (mm)	1.27 mm
Plating min: Mating (µin)	2
Plating min: Mating (µm)	0.05
Plating min: Termination (µin)	100
Plating min: Termination (µm)	2.5
Polarized to Mating Part	Yes
Surface Mount Compatible (SMC)	Yes
Temperature Range - Operating	-20°C to +80°C
Termination Interface: Style	Surface Mount
Wire Size AWG	N/A

**Electrical**

Current - Maximum per Contact	1A
Shielded	Yes
Voltage - Maximum	40V

**Solder Process Data**

Duration at Max. Process Temperature (seconds)	5
Lead-free Process Capability	Wave Capable (TH only)
Max. Cycles at Max. Process Temperature	1

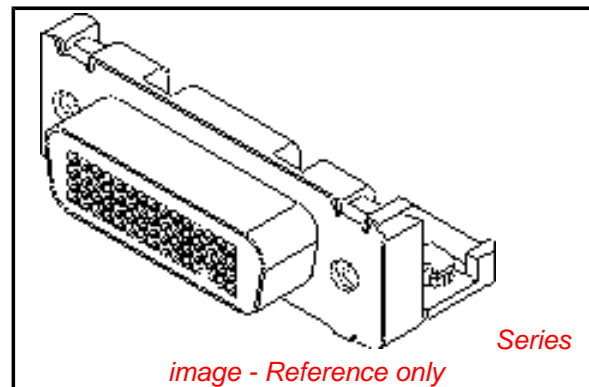

*image - Reference only*

**EU RoHS**

**ELV and RoHS  
Compliant**  
**REACH SVHC  
Contains SVHC: No**  
**Halogen-Free  
Status**

**China RoHS**



**Need more information on product  
environmental compliance?**

Email [productcompliance@molex.com](mailto:productcompliance@molex.com)  
For a multiple part number RoHS Certificate of  
Compliance, [click here](#)

Please visit the [Contact Us](#) section for any  
non-product compliance questions.

**Search Parts in this Series**

[75134Series](#)

**Mates With**

[75135](#)

**Use With**

[70982](#) Panel Mount Hex Screw Kit

Process Temperature max. C

245

**Material Info**

**Reference - Drawing Numbers**

Packaging Specification

PK-70873-0291

Product Specification

PS-75134-001

Sales Drawing

SD-75134-001

This document was generated on 05/28/2010

**PLEASE CHECK [WWW.MOLEX.COM](http://WWW.MOLEX.COM) FOR LATEST PART INFORMATION**

ITEM NUMBER	DIMENSION "A"	HEXAGONAL SCREWLOCKS PACKAGED WITH CONNECTORS	SCREWLOCK ITEM NUMBER (SEE SD-70982-****)	PACKAGED PER PACKAGING SPECIFICATION
75134-1000	.092±.010/2.34±0.25	NO		PK-70873-0291
75134-1001	.092±.010/2.34±0.25	YES	70982-1003; 4-40 INTERNAL THD	PK-70873-0686

NOTES:

1) MATERIALS:

HOUSING: GLASS FILLED LCP (LIQUID CRYSTAL POLYMER), UL94 V-0, COLOR NATURAL.  
 STICK HOUSING: GLASS FILLED LCP (LIQUID CRYSTAL POLYMER), UL94 V-0, COLOR BLACK.  
 TERMINALS: COPPER ALLOY.  
 OUTER SHELL: DEEP DRAWN STEEL.  
 HEXAGONAL SCREWLOCK: STEEL.

2) PLATING :

TERMINAL: SELECTIVE GOLD (Au) FLASH IN CONTACT AREA;  
 THICKNESS= 2 TO 10 MICROINCHES/0.05 TO 0.25 MICROMETERS;  
 SELECTIVE TIN (Sn) ALLOY IN THE PC TAIL AREA;  
 THICKNESS=100 MICROINCHES/2.54 MICROMETERS MINIMUM;  
 NICKEL (Ni) UNDERPLATE OVER ENTIRE PIN.

OUTER SHELL: 150 MICROINCHES/3.81 MICROMETERS MINIMUM OF BRIGHT TIN  
 OVER 50 MICROINCHES/1.27 MICROMETERS MINIMUM OF NICKEL  
 OVER COPPER FLASH (OPTIONAL).

3) CONFORMS TO PRODUCT SPECIFICATION PS-75134-001.

4) THREAD GAGE MAY REQUIRE UP TO 1 INCH-POUND/0.113 NEWTON-METER OF TORQUE DURING GAGING PROCESS.

5) SEE CHART FOR PACKAGING.

6) PART COMPLIES WITH CLASS B OF COSMETIC SPECIFICATION PS-45499-002

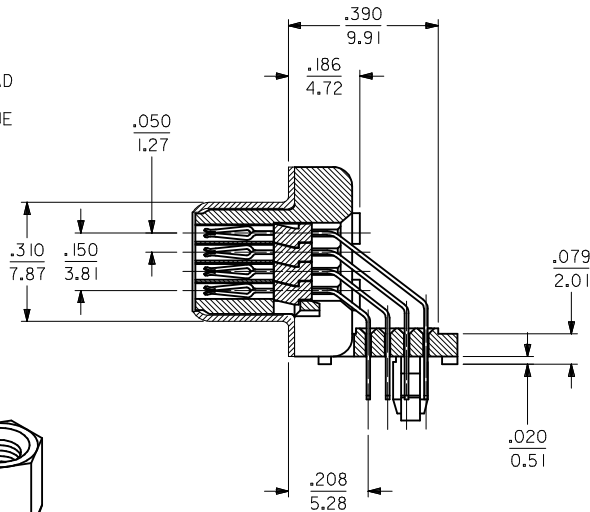
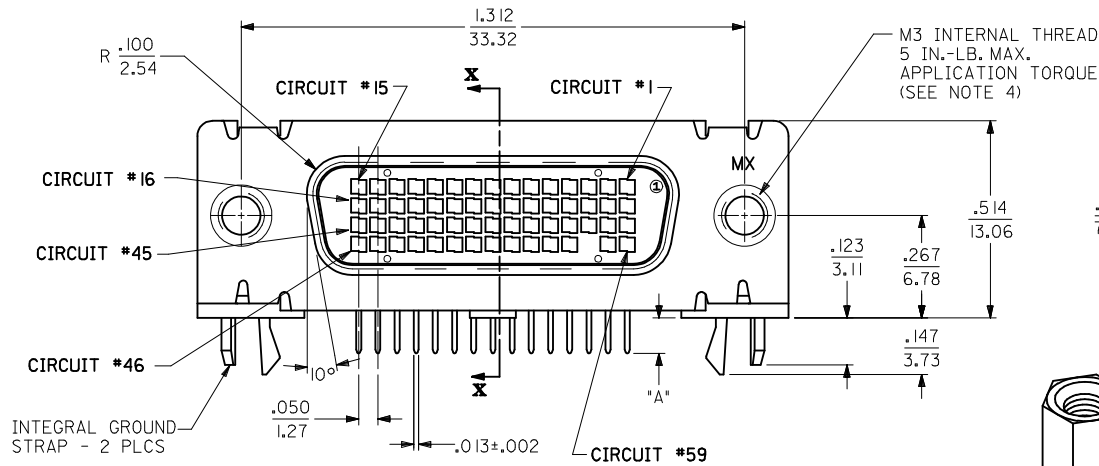
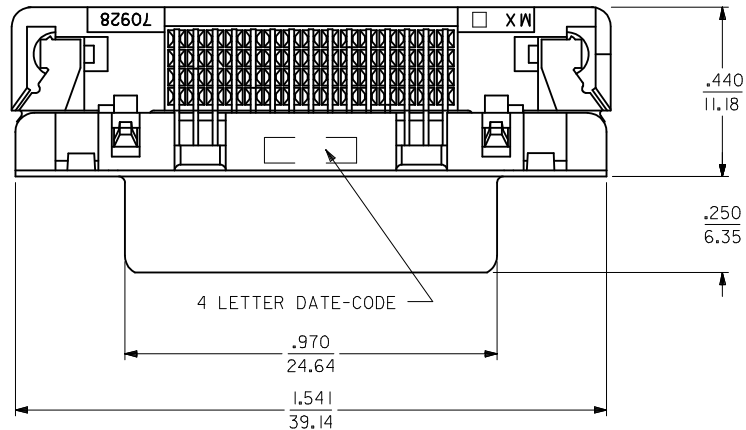

SECTION X-X

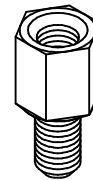

OPTIONAL HEXAGONAL SCREWLOCK

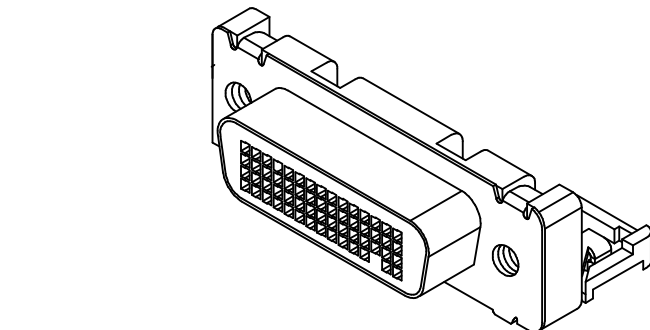

MODIFY T/A ACTUAL EC NO: UCP2009-2635 DRWING:MORGAN 2009/04/29 CHKD:SDANNELLEY 2009/04/30 APPR:SMILLER 2009/04/30	QUALITY SYMBOLS ▽=0 ▽=0	GENERAL TOLERANCES (UNLESS SPECIFIED)		DIMENSION STYLE	SCALE	DESIGN UNITS	THIRD ANGLE PROJECTION	
				IN/MM	INCH	INCH		
				DRAWN BY	DATE	TITLE		
				CHECKED BY	DATE			
D REV DESCRIPTION	DRAFT WHERE APPLICABLE MUST REMAIN WITHIN DIMENSIONS	4 PLACES ± --- ± --- 3 PLACES ± --- ± .010 2 PLACES ± 0.25 ± .015 1 PLACE ± 0.38 ± --- ANGULAR ± 1/2°		DMORGAN 2002/10/18 BBARKER 2002/10/18 SMILLER 2002/10/18	SALES DMS-59 RECEPTACLE LFH .050/1.27 PITCH RIGHT ANGLE I/O 59 CKT			
		MATERIAL NO. <b>SEE TABLE</b>		MOLEX INCORPORATED				
		SIZE C		DOCUMENT NO. <b>SD-75134-001</b>				
		THIS DRAWING CONTAINS INFORMATION THAT IS PROPRIETARY TO MOLEX INCORPORATED AND SHOULD NOT BE USED WITHOUT WRITTEN PERMISSION		SHEET NO. 1 OF 2				

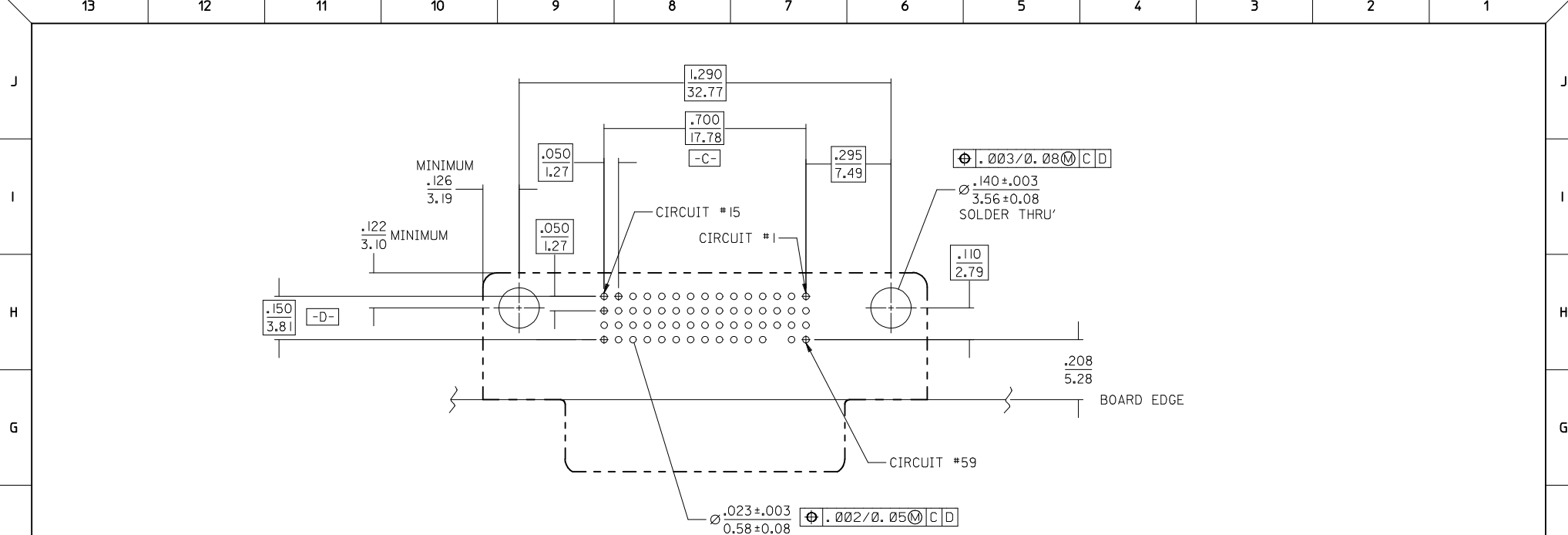

COMPONENT SIDE  
RECOMMENDED P.C.B. LAYOUT

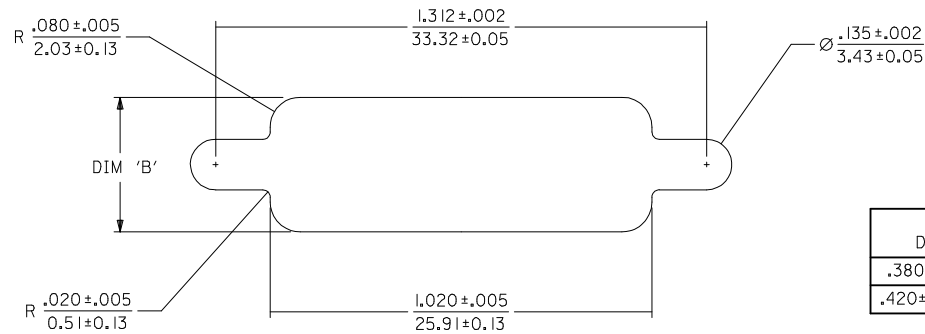

DIMENSION 'B'	MAXIMUM PANEL THICKNESS
$.380 \pm .005 / 9.65 \pm 0.13$	.039/0.99
$.420 \pm .005 / 10.67 \pm 0.13$	.064/1.63

RECOMMENDED PANEL CUT-OUT

<b>SEE SHEET 1</b> IEC NO: UCP2009-2635 DRW:DMORGAN 2009/04/28 CHK:D.SANNELLEY 2009/04/30 APPR:SMILLER 2009/04/30	QUALITY SYMBOLS $\blacktriangledown = 0$ $\blacktriangledown = 0$	GENERAL TOLERANCES (UNLESS SPECIFIED)		DIMENSION STYLE <b>IN/MM</b>		SCALE <b>4:1</b>	DESIGN UNITS <b>INCH</b>	$\text{THIRD ANGLE PROJECTION}$	
		4 PLACES $\pm .010$	3 PLACES $\pm .010$	DRAWN BY DMORGAN	DATE 2002/10/18	TITLE <b>SALES DMS-59 RECEPTACLE          LFH .050/1.27 PITCH          RIGHT ANGLE I/O 59 CKT</b>			
		2 PLACES $\pm .025$	1 PLACE $\pm .038$	CHECKED BY BBARKER	DATE 2002/10/18	APPROVED BY SMILLER			
		ANGULAR $\pm 1/2^\circ$		MATERIAL NO. <b>SEE TABLE</b>		DOCUMENT NO. <b>SD-75134-001</b>		SHEET NO. <b>2 OF 2</b>	
DRAFT WHERE APPLICABLE MUST REMAIN WITHIN DIMENSIONS				THIS DRAWING CONTAINS INFORMATION THAT IS PROPRIETARY TO MOLEX INCORPORATED AND SHOULD NOT BE USED WITHOUT WRITTEN PERMISSION					

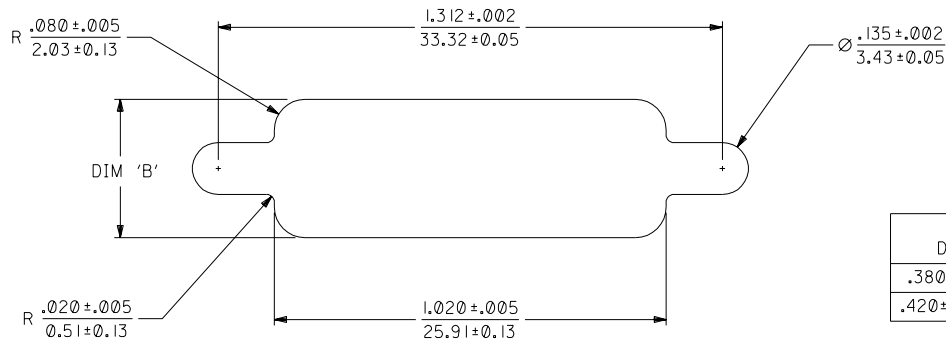
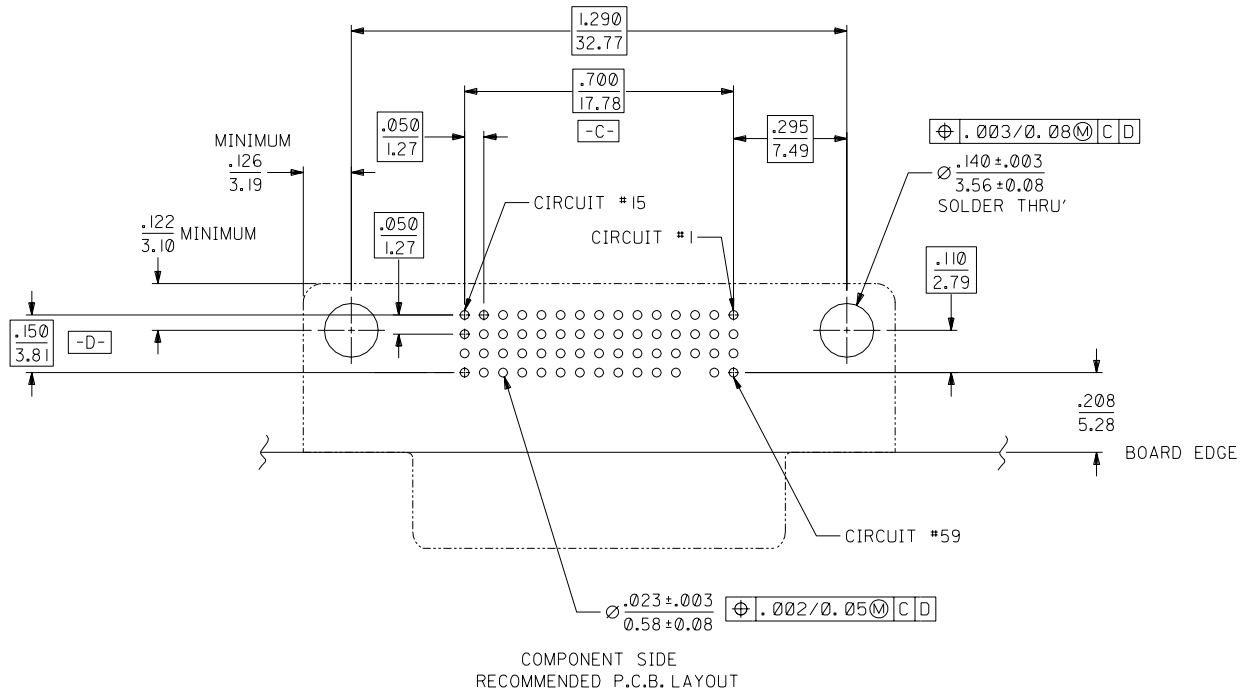

DIMENSION 'B'	MAXIMUM PANEL THICKNESS
.380 ± .005 / 9.65 ± 0.13	.039 / 0.99
.420 ± .005 / 10.67 ± 0.13	.064 / 1.63

RECOMMENDED PANEL CUT-OUT

INITIAL RELEASE EC NO. UCP2003-0543 DRWN:DMORGAN 02/10/18 CHK: BBARKER 02/10/18 APPR:SMILLER 02/10/18	DESCRIPTION MAJOR CRITICAL REV	QUALITY SYMBOLS MAJOR CRITICAL	GENERAL TOLERANCES: (UNLESS SPECIFIED) mm INCH	SCALE 4:1	DESIGN UNITS mm INCH	DIMENSIONS: mm INCH mm ONLY	SHT REV
		4 PLACES ±0. ±.	DRAWN BY & DATE DMORGAN 02/10/18	THIRD ANGLE PROJECTION	TITLE: SALES DMS-59 RECEPTALCE LFH .050/1.27 PITCH RIGHT ANGLE I/O 59 CKT	REVISE ON CAD ONLY	
		3 PLACES ±0. ±.010	CHECKED BY & DATE BBARKER 02/10/18	APPROVED BY & DATE SMILLER 02/10/18	MATERIAL NO. SEE CHART	DRAWING NO. SD-75134-001	SHEET NO. 2
		2 PLACES ±0.25 ±.015 1 PLACE ±0.38 ±.	ANGULAR: ± 1/2 °	CAD FILENAME	MOLEX INCORPORATED	THIS DRAWING CONTAINS INFORMATION THAT IS PROPRIETARY TO MOLEX INCORPORATED AND SHOULD NOT BE USED WITHOUT WRITTEN PERMISSION.	SIZE C

Компания «Life Electronics» занимается поставками электронных компонентов импортного и отечественного производства от производителей и со складов крупных дистрибьюторов Европы, Америки и Азии.

С конца 2013 года компания активно расширяет линейку поставок компонентов по направлению коаксиальный кабель, кварцевые генераторы и конденсаторы (керамические, пленочные, электролитические), за счёт заключения дистрибьюторских договоров

Мы предлагаем:

- Конкурентоспособные цены и скидки постоянным клиентам.
- Специальные условия для постоянных клиентов.
- Подбор аналогов.
- Поставку компонентов в любых объемах, удовлетворяющих вашим потребностям.
- Приемлемые сроки поставки, возможна ускоренная поставка.
- Доставку товара в любую точку России и стран СНГ.
- Комплексную поставку.
- Работу по проектам и поставку образцов.
- Формирование склада под заказчика.
- Сертификаты соответствия на поставляемую продукцию (по желанию клиента).
- Тестирование поставляемой продукции.
- Поставку компонентов, требующих военную и космическую приемку.
- Входной контроль качества.
- Наличие сертификата ISO.

В составе нашей компании организован Конструкторский отдел, призванный помогать разработчикам, и инженерам.

Конструкторский отдел помогает осуществить:

- Регистрацию проекта у производителя компонентов.
- Техническую поддержку проекта.
- Защиту от снятия компонента с производства.
- Оценку стоимости проекта по компонентам.
- Изготовление тестовой платы монтаж и пусконаладочные работы.



Тел: +7 (812) 336 43 04 (многоканальный)

Email: [org@lifeelectronics.ru](mailto:org@lifeelectronics.ru)