

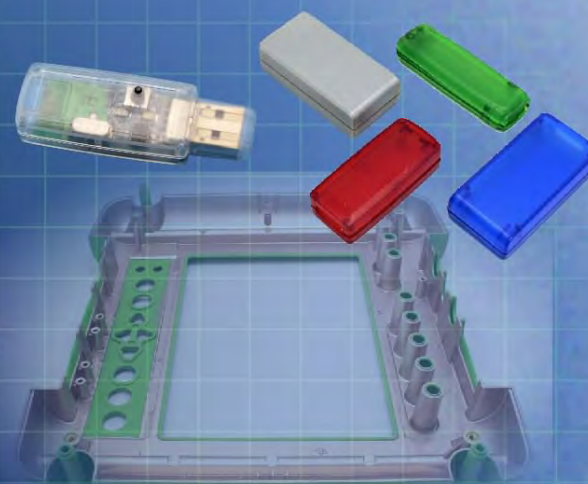

Ordering a market-ready enclosure® is made fast and affordable with our complete in-house capabilities. New Age provides machined openings to fit your PCB, pad printing for your graphics, custom enclosures, custom colors, final assembly, testing and fulfillment services to save you additional time and money. Ask your representative for a free quote today 805-595-1310.

Fast and Affordable Customization

**CNC Modifications
Pad Printing
Colored Resins
EMI/RF Shielding
Custom Enclosure
Assembly & Testing**



ISO quality
off-the-shelf
to market-ready®

NEW AGE ENCLOSURES

www.NewAgeEnclosures.com

4330 Santa Fe Road • San Luis Obispo, CA 93401 • T 805.595.1310 • F 805.595.1024

NOTES: UNLESS OTHERWISE SPECIFIED

- CORNERS DRAWN SHARP TO BE R.005 MAXIMUM.
- EXTERIOR SURFACE TEXTURE TO BE LIGHT EDM FINISH. EQUIVELANT TO MT-11020. CENTER PART TO BE POLISHED.
- INTERIOR SURFACE TEXTURE TO BE: NONE.
- ALL INSIDE RADII .010R. UNLESS OTHERWISE SPECIFIED.
- ALL EXTERNAL DIMENSIONS AFFECTED BY THE DRAFT APPLY AT THE LARGE END OF THE FEATURE, AND ALL INTERNAL FEATURES AFFECTED BY THE DRAFT APPLY AT THE SMALL END OF THE FEATURE UNLESS OTHERWISE SPECIFIED.
- 1 DEGREE DRAFT IN THE DIRECTION OF PULL IS PERMISSIBLE UNLESS OTHERWISE SPECIFIED.
- ASSEMBLY SCREWS FOR THE ENCLOSURE ARE INCLUDED. MOUNTING SCREWS FOR THE PCB AND WALL ARE SOLD SEPERATELY.
- MATERIAL / COLOR: ASA PLASTIC IS STANDARD IN BLACK OR GRAY. CUSTOM MATERIALS AND COLORS ARE AVAILABLE UPON REQUEST FOR QUOTE.
- PCB SIZES ARE RECOMMENDATIONS ONLY. FINAL SIZES AND VERIFICATION OF IT'S FIT ARE THE SOLE RESPONSIBILITY OF OEM.

R E V I S I O N					
REV.	DRAWN BY	ECO No	DESCRIPTION	DATE	APPROVED
A	M BOYER	DR XXX	PRELIMINARY RELEASE	17-Sep-10	D.C.
J	M BOYER		INCLUDE STANDARD CONFIG IN BOM	27-Jan-12	D.C.
1.0	M BOYER		UPDATE TO AS-BUILT AND RELEASED TO MFG	23-May-12	

452715(x) CONFIGURATIONS

	-SW	-BS	-SS	-BW	-OM	-OB
452715 BATTERY COVER		1		1		
452715 COVER (w/o BATTERY)	1		1			
452715 BASE		1	1			
452715 WALL BASE	1			1		
452715 HATCH		1		1		
6-32 PHILLIPS HEAD SCREW x .500"		4		4		
6-32 PHILLIPS HEAD SCREW x .375"	4		4			
8-32 PHILLIPS HEAD SCREW x .500"		2		2		
OUTDOOR KIT					1	1

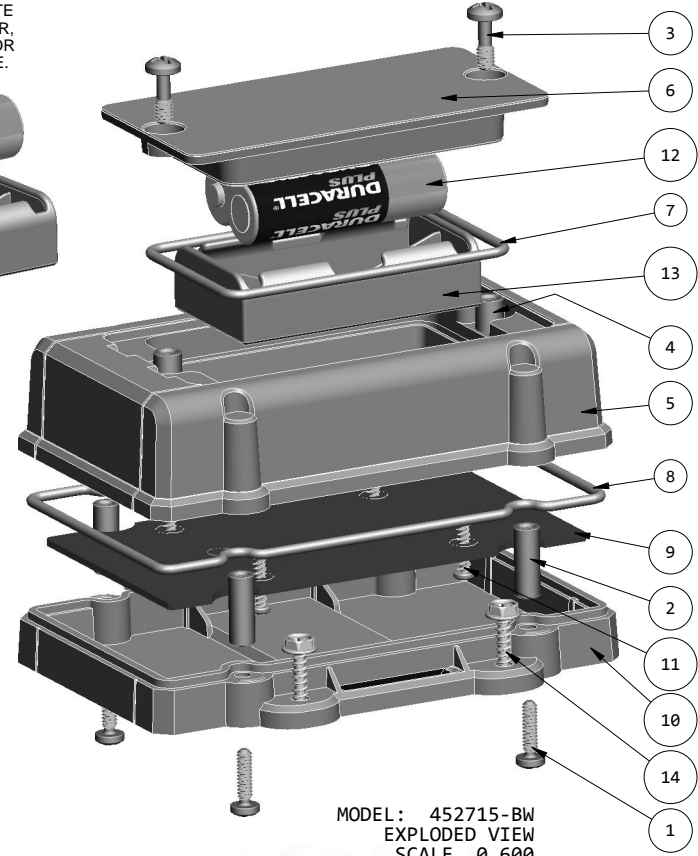
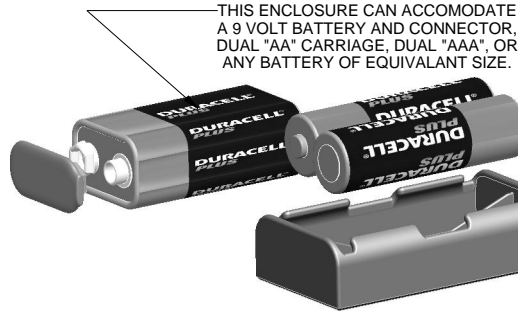

MODEL: 452715-BW
EXPLODED VIEW
SCALE 0.600

7	#4 HiLo x .250" SCREW	ZINK PLATED	SOLD SEPERATELY	4
6	452715 O-RING, MAIN SEAL x .070"	ETHYLENE-PROPYLENE, NATURAL	SOLD SEPERATELY	1
5	6-32 x .312" INSERT	MMC 93365A142	OVER-MOLDED BRASS	4
4	452715 PCB - REFERENCE	.062" THICK	CUSTOMER SUPPLIED	1
3	452715 COVER - STANDARD	ASA	BLACK or GRAY	1
2	452715 BASE - STANDARD	ASA	BLACK or GRAY	1
1	6-32 SCREW x .500	STAINLESS STEEL - PHILLIPS	.500" LONG	4

BILL OF MATERIALS - Standard Base & Standard Cover (Not Shown)

14	No6 SHEET METAL SCREW x 1.00"	410 STAINLESS	CUSTOMER SUPPLIED	4
13	BATTERY CARRIAGE AA - REFERENCE	KEYST # 2463	CUSTOMER SUPPLIED	1
12	AA BATTERY - REFERENCE	"AA" BATTERY SIZE	CUSTOMER SUPPLIED	2
11	#4 HiLo x .250" SCREW	ZINK PLATED	SOLD SEPERATELY	4
10	452715 WALL BASE - STANDARD	ASA	BLACK or GRAY	1
9	452715 PCB - REFERENCE	.062" THICK	CUSTOMER SUPPLIED	1
8	452715 O-RING, MAIN SEAL x .070"	ETHYLENE-PROPYLENE, NATURAL	SOLD SEPERATELY	1
7	452715 O-RING, BATT COMP x .070"	ETHYLENE-PROPYLENE, NATURAL	SOLD SEPERATELY	1
6	452715 HATCH - STANDARD	ASA	BLACK or GRAY	1
5	452715 BATTERY COVER - STANDARD	ASA	BLACK or GRAY	1
4	8-32 x .344" CLOSED-END INSERT	TRISTAR 832X344MC	OVER-MOLDED BRASS	2
3	8-32 SCREW x .375	STAINLESS STEEL - PHILLIPS	.375" LONG	2
2	6-32 x .625" INSERT	BRASS	OVER-MOLDED BRASS	4
1	6-32 SCREW x .500	STAINLESS STEEL - PHILLIPS	.500" LONG	4

ITEM	DESCRIPTION	MATERIAL	COLOR	QTY.
BILL OF MATERIALS - Wall Base & Battery Cover				

THIRD ANGLE PROJECTION
DO NOT SCALE DRAWING

TOLERANCES: UNLESS OTHERWISE SPECIFIED
DIMENSIONS ARE IN U.S. INCHES.
X.XX = .015 X.XXXX = .001
X.XXX = .010 X.X" = 1°

NEW AGE ENCLOSURES
4330 Santa Fe Road San Luis Obispo, CA. 93401
ph. (805) 595-1310 fax (805) 595-1024

Customer's Part No: 452715

APPROVAL	BY	DATE
CHECK		
ENG.		
SCALE	AS NOTED	

**STAND - INDUSTRIAL UTIL
SLX-452715X-XXX**

DRAWN BY
M BOYER Sep-17-10

SIZE A
DRAWING NAME
452715_R1_0

SHEET 1 OF 11
REV.DOC 1.0

452715-BW ASSEMBLY
COVER w/ BATTERY - WALL BASE

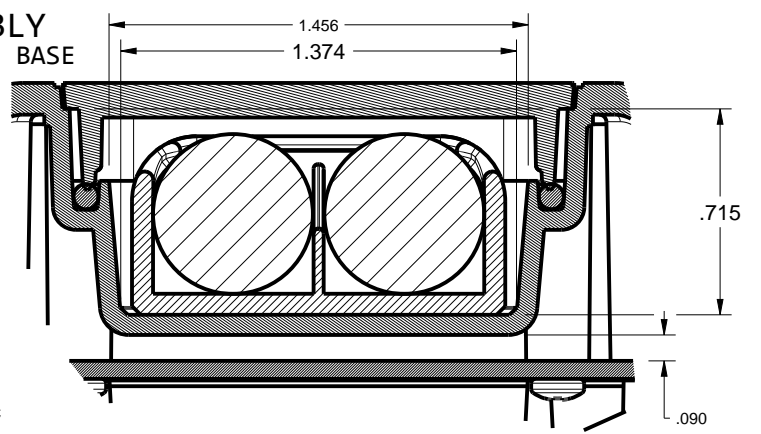
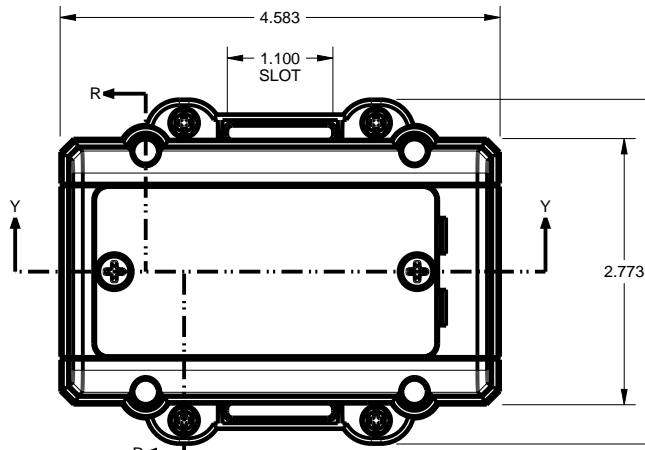

ASSEMBLY VIEW: 452715-BW
SCALE 0.500

DETAIL C: 452715-BW
SCALE 1.500

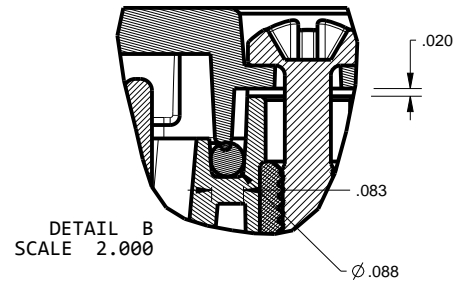
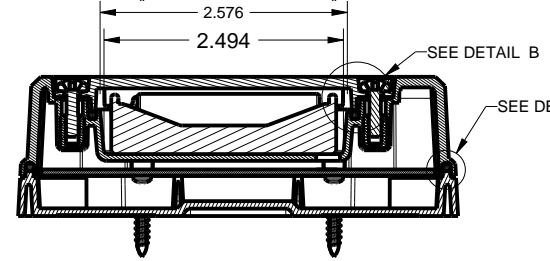
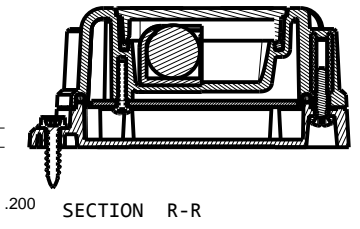
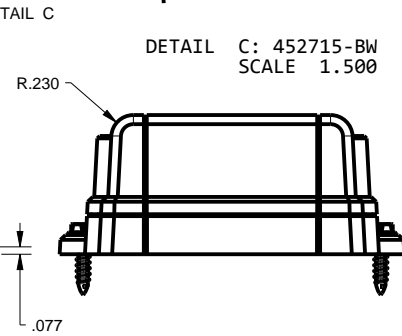
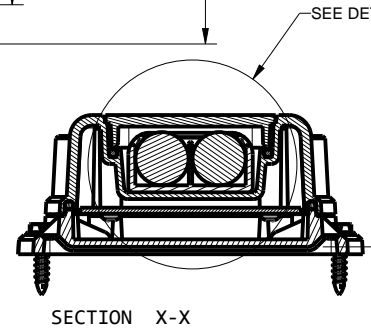
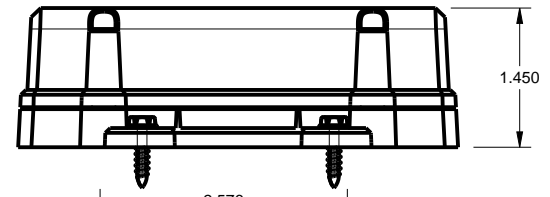

DETAIL B
SCALE 2.000

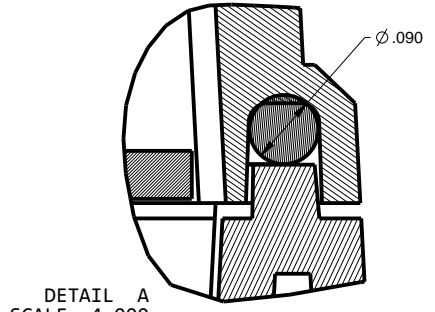
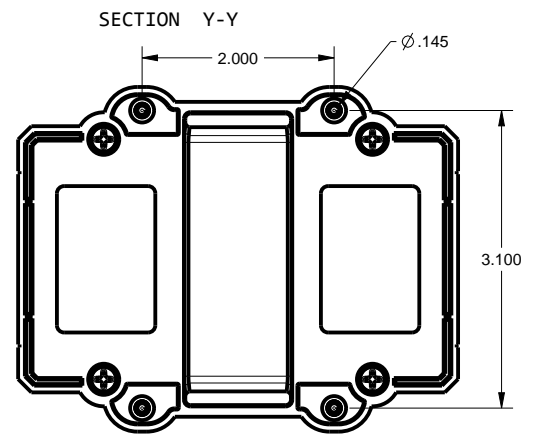

DETAIL A
SCALE 4.000

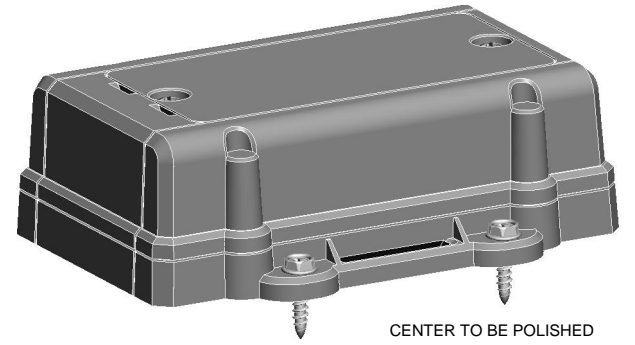

ISO VIEW: 452715-BW
SCALE 0.600

TOLERANCES: UNLESS OTHERWISE SPECIFIED DIMENSIONS ARE IN U.S. INCHES.		NEW AGE ENCLOSURES	
X.XX = .015 X.XXXX = .001 X.XXX = .010 X.X° = 1°			
NEW AGE ENCLOSURES		4330 Santa Fe Road San Luis Obispo, CA. 93401 ph. (805) 595-1310 fax (805) 595-1024 www.newageenclosures.com	
Customer's Part No: 452715		STAND - INDUSTRIAL UTIL SLX-452715X-XXX	
APPROVAL	BY DATE		
CHECK		SHEET 2 OF 11	
ENG.			
SCALE	AS NOTED	REV.DOC 1.0	
DRAWN BY	Sep-17-10		
M BOYER		SIZE A	DRAWING NAME 452715_R1_0

452715-SS ASSEMBLY
COVER - BASE

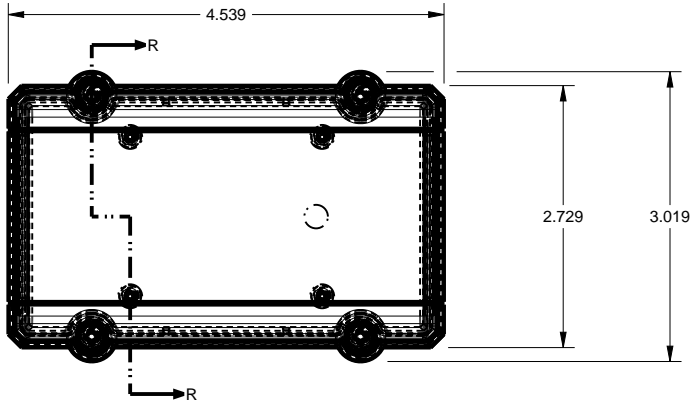

ASSEMBLY VIEW: 452715-SS
SCALE 0.500

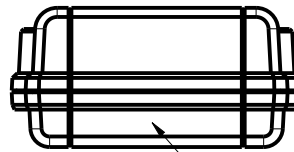
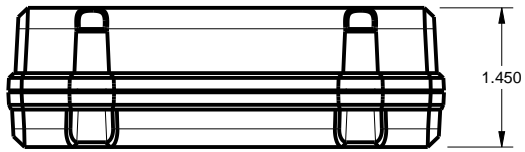
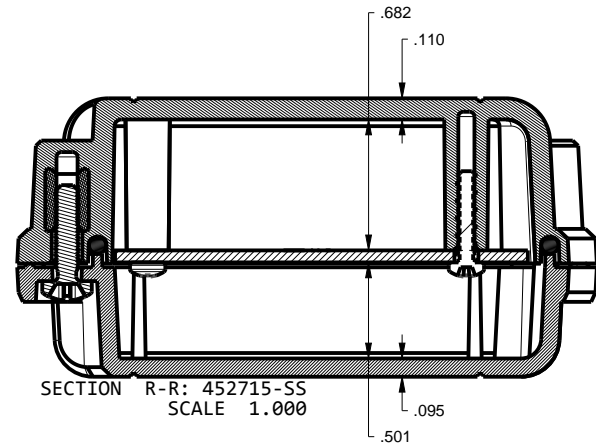

CENTER SECTION
TO BE POLISHED

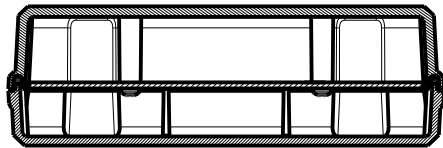

SECTION Y-Y

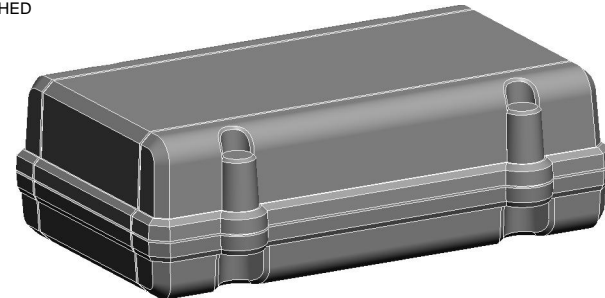

ISO VIEW: 452715-SS
SCALE 0.600

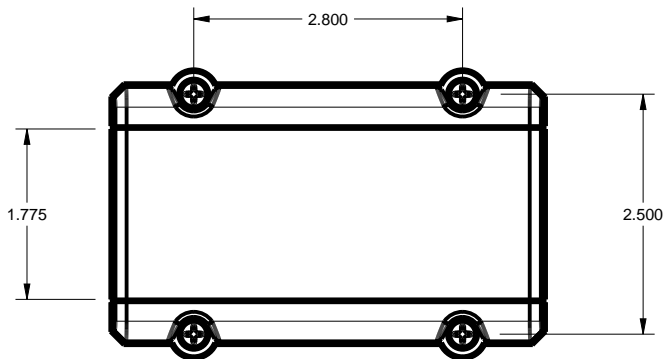

TOLERANCES: UNLESS OTHERWISE SPECIFIED
DIMENSIONS ARE IN U.S. INCHES.
X.XX = .015 X.XXXX = .001
X.XXX = .010 X.X° = 1°

Customer's Part No: 452715

APPROVAL BY DATE

CHECK

ENG.

SCALE AS NOTED

DRAWN BY M BOYER Sep-17-10

NEW AGE ENCLOSURES

4330 Santa Fe Road San Luis Obispo, CA. 93401
ph. (805) 595-1310 fax (805) 595-1024
www.newageenclosures.com

**STAND - INDUSTRIAL UTIL
SLX-452715X-XXX**

SIZE A DRAWING NAME 452715_R1_0

SHEET 3 OF 11 REV.DOC 1.0

452715 BATTERY COVER
FOR USE IN CONFIG: -BS -BW

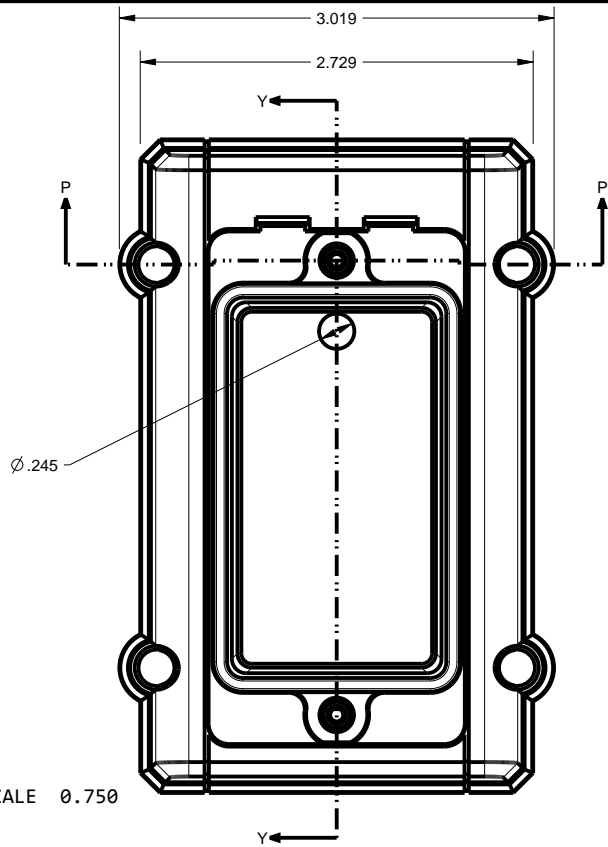

SCALE 0.750

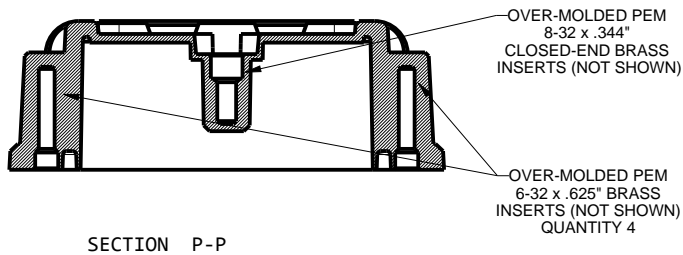
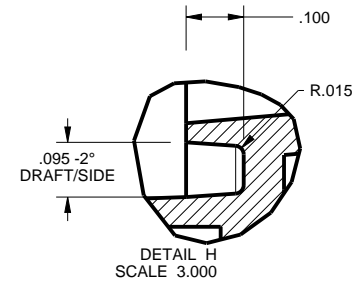
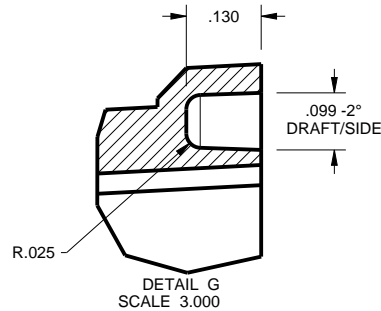
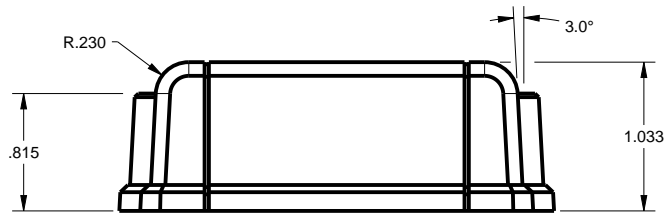
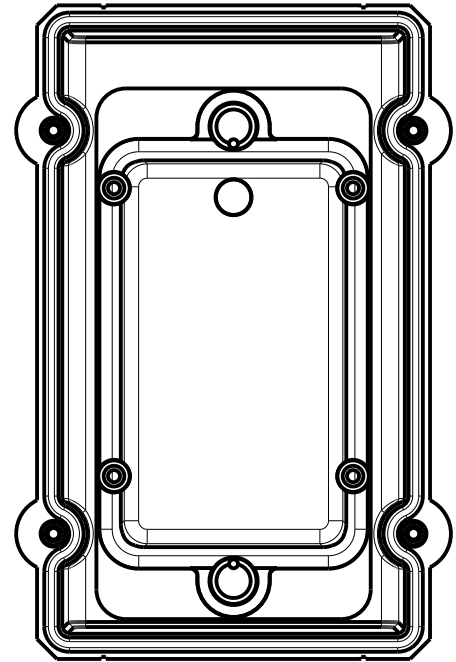
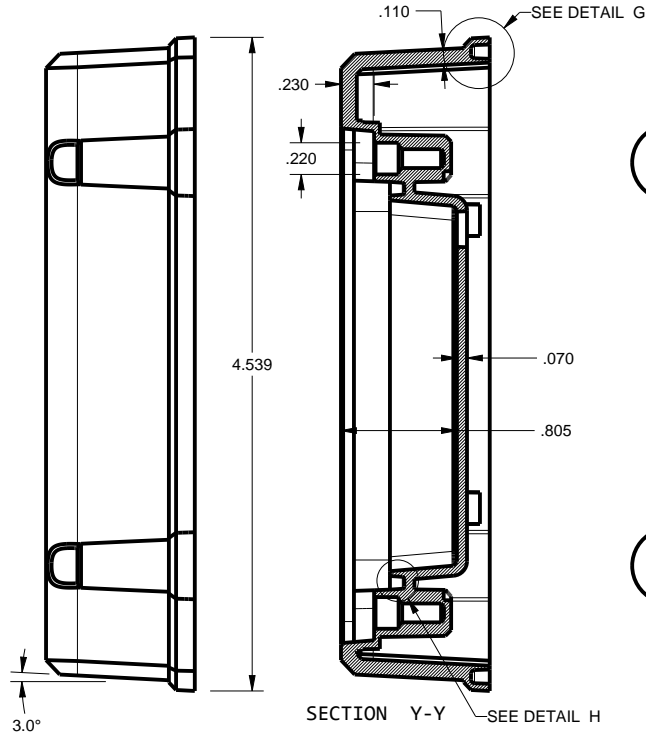

SECTION P-P

TOLERANCES: UNLESS OTHERWISE SPECIFIED
DIMENSIONS ARE IN U.S. INCHES.
X.XX = .015 X.XXXX = .001
X.XXX = .010 X.X° = 1°

NEW AGE ENCLOSURES

Customer's Part No: 452715

APPROVAL BY DATE

CHECK

ENG.

SCALE AS NOTED

DRAWN BY M BOYER Sep-17-10

NEW AGE ENCLOSURES

4330 Santa Fe Road San Luis Obispo, CA. 93401
ph. (805) 595-1310 fax (805) 595-1024
www.newageenclosures.com

STAND - INDUSTRIAL UTIL
SLX-452715X-XXX

SIZE A DRAWING NAME 452715_R1_0

SHEET 4 OF 11 REV.DOC 1.0

452715 COVER
FOR USE IN CONFIG: -SW -SS

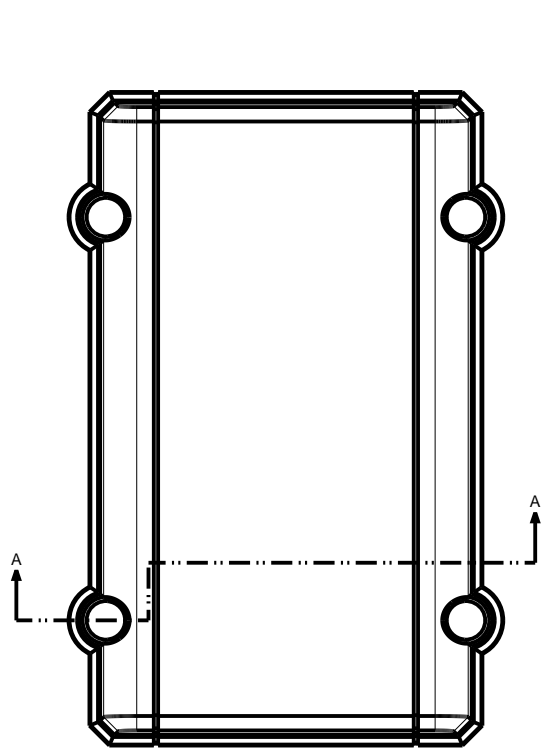

SCALE 0.750

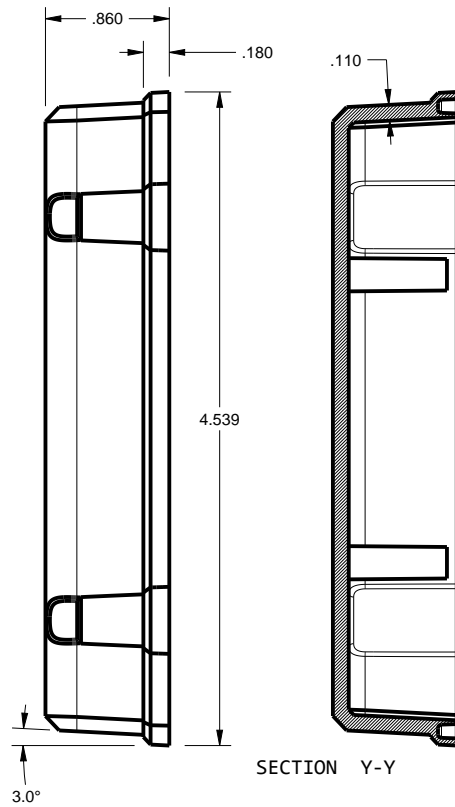

SECTION Y-Y

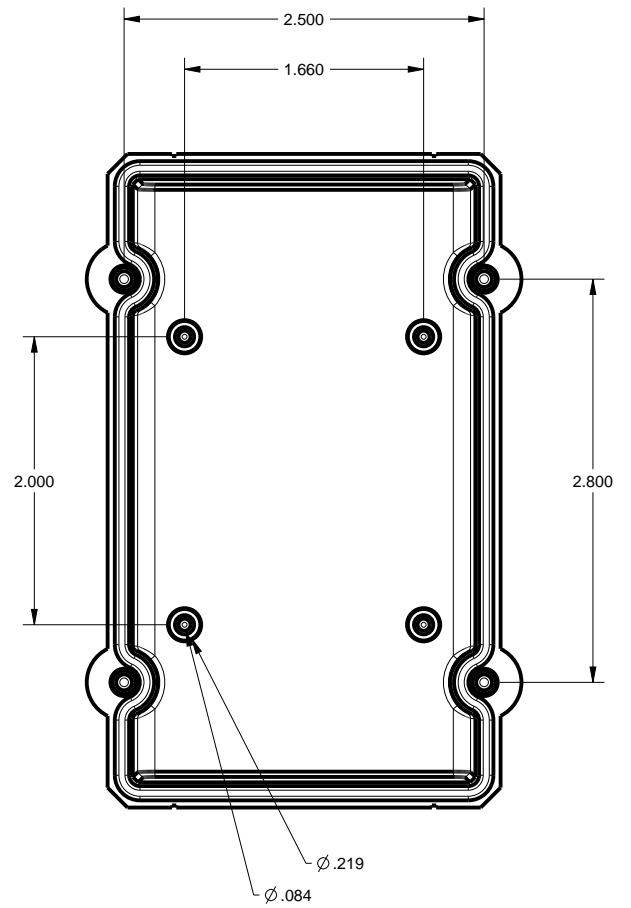

OVER-MOLDED PEM
6-32 x .312" BRASS
INSERTS (NOT SHOWN)

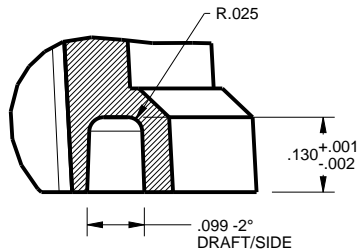
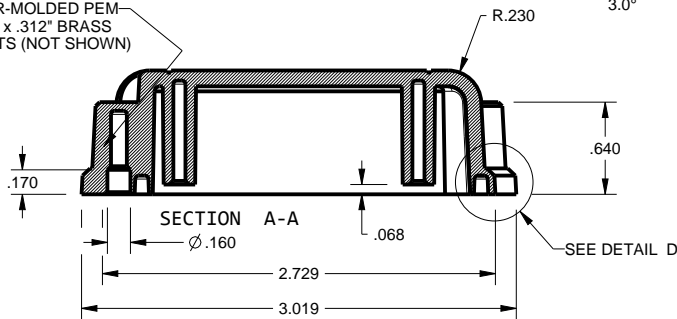

DETAIL D
SCALE 3.000

TOLERANCES: UNLESS OTHERWISE SPECIFIED
DIMENSIONS ARE IN U.S. INCHES.
X.XX = .015 X.XXXX = .001
X.XXX = .010 X.X° = 1°

NEW AGE ENCLOSURES

Customer's Part No: 452715

APPROVAL BY DATE

CHECK

ENG.

SCALE AS NOTED

DRAWN BY M BOYER Sep-17-10

NEW AGE ENCLOSURES

4330 Santa Fe Road San Luis Obispo, CA. 93401
ph. (805) 595-1310 fax (805) 595-1024

www.newageenclosures.com

STAND - INDUSTRIAL UTIL
SLX-452715X-XXX

SIZE A DRAWING NAME 452715_R1_0

SHEET 5 OF 11

REV.DOC 1.0

452715 WALL BASE
FOR USE IN CONFIG: -SW -BW

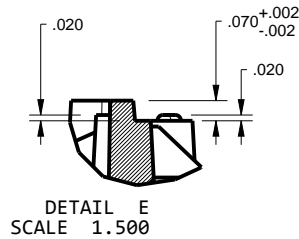
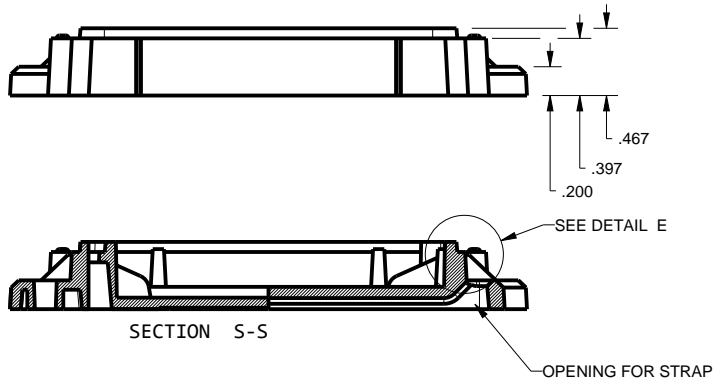
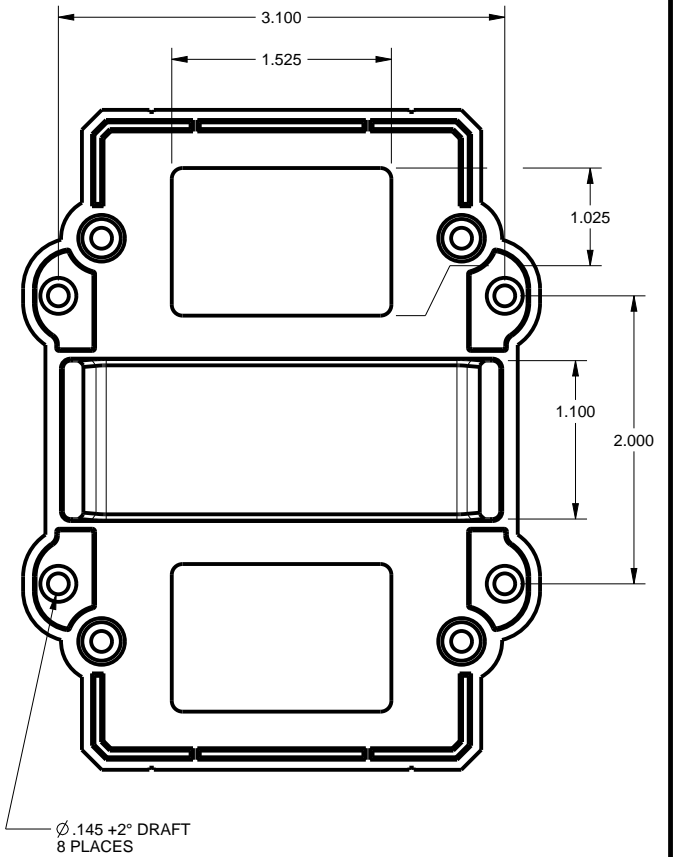
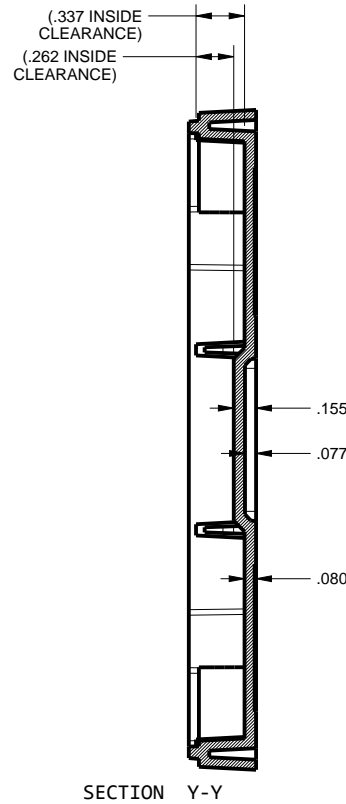
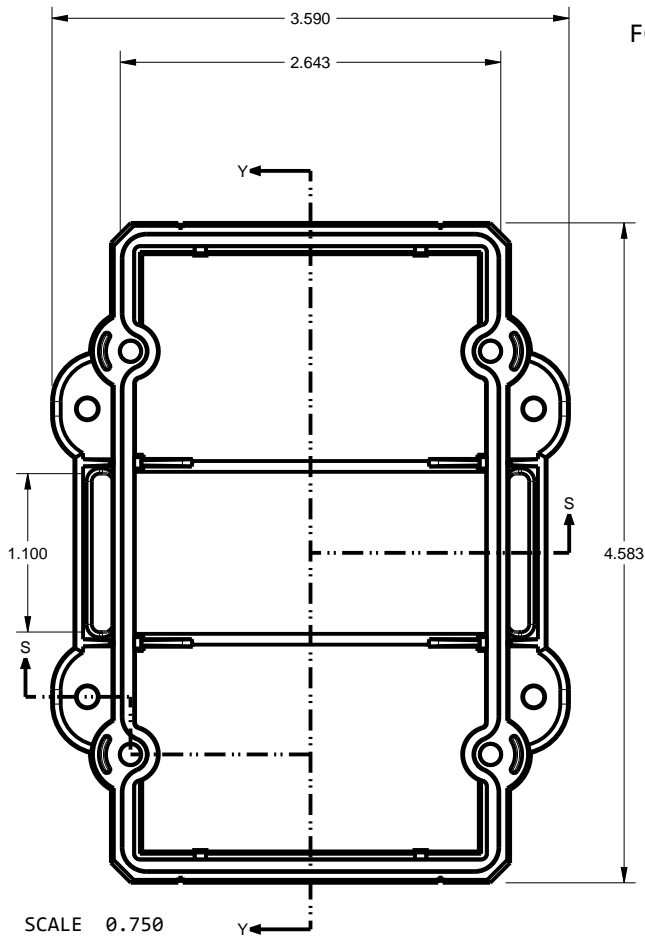

TOLERANCES: UNLESS OTHERWISE SPECIFIED
DIMENSIONS ARE IN U.S. INCHES.

X.XX = .015 X.XXXX = .001
X.XXX = .010 X.X° = 1°

NEW AGE ENCLOSURES

Customer's Part No: 452715

APPROVAL BY DATE

CHECK

ENG.

SCALE AS NOTED

DRAWN BY M BOYER Sep-17-10

NEW AGE ENCLOSURES

4330 Santa Fe Road San Luis Obispo, CA. 93401
ph. (805) 595-1310 fax (805) 595-1024

www.newageenclosures.com

STAND - INDUSTRIAL UTIL
SLX-452715X-XXX

SIZE A DRAWING NAME 452715_R1_0

SHEET 6 OF 11 REV.DOC 1.0

452715 BASE
FOR USE IN CONFIG: -SS -BS

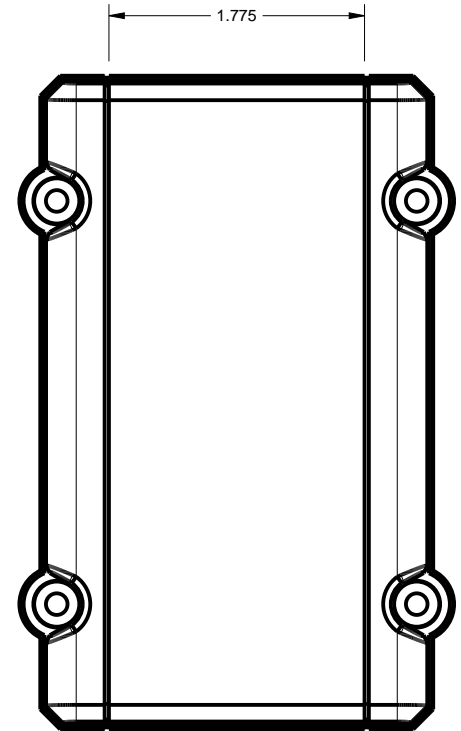
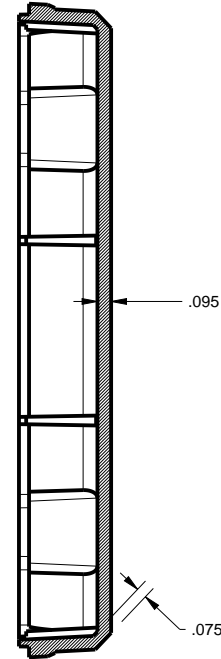
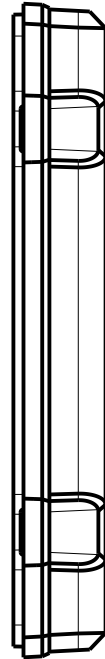
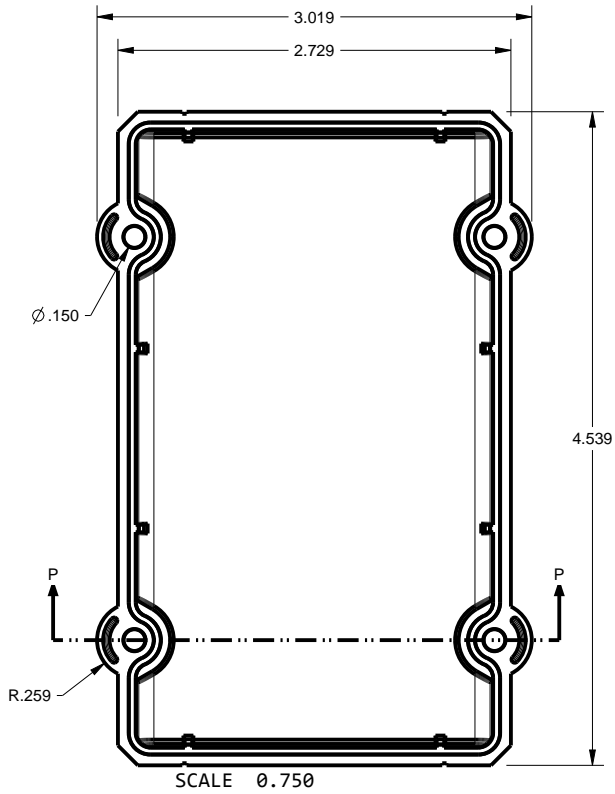

SECTION Y-Y

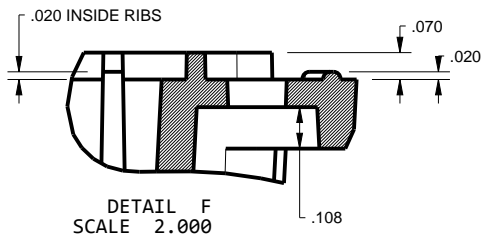
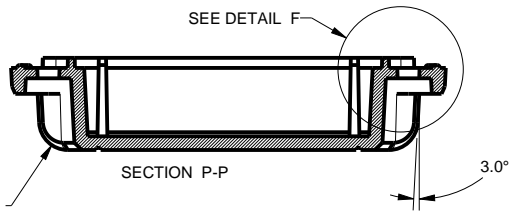
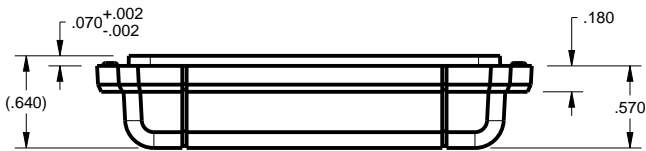

TOLERANCES: UNLESS OTHERWISE SPECIFIED
DIMENSIONS ARE IN U.S. INCHES.

X.XX = .015 X.XXXX = .001
X.XXX = .010 X.X° = 1°

NEW AGE ENCLOSURES

Customer's Part No: 452715

APPROVAL BY DATE

CHECK

ENG.

SCALE AS NOTED

DRAWN BY M BOYER Sep-17-10

NEW AGE ENCLOSURES

4330 Santa Fe Road San Luis Obispo, CA. 93401
ph. (805) 595-1310 fax (805) 595-1024

www.newageenclosures.com

**STAND - INDUSTRIAL UTIL
SLX-452715X-XXX**

SIZE A DRAWING NAME 452715_R1_0

SHEET 7 OF 11 REV.DOC 1.0

452715 HATCH
FOR USE IN CONFIG: -BS -BW

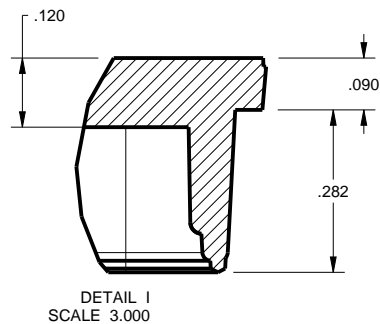
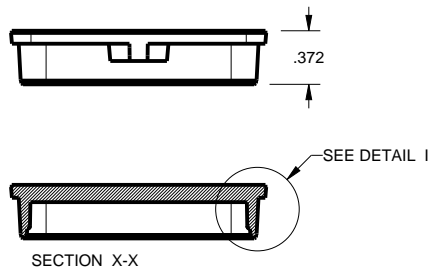
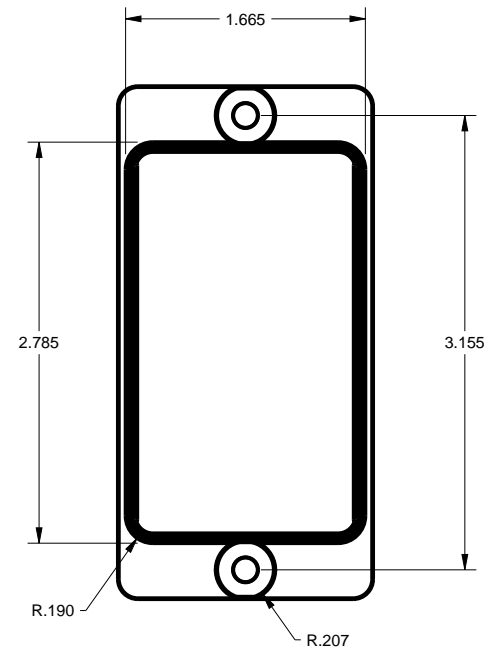
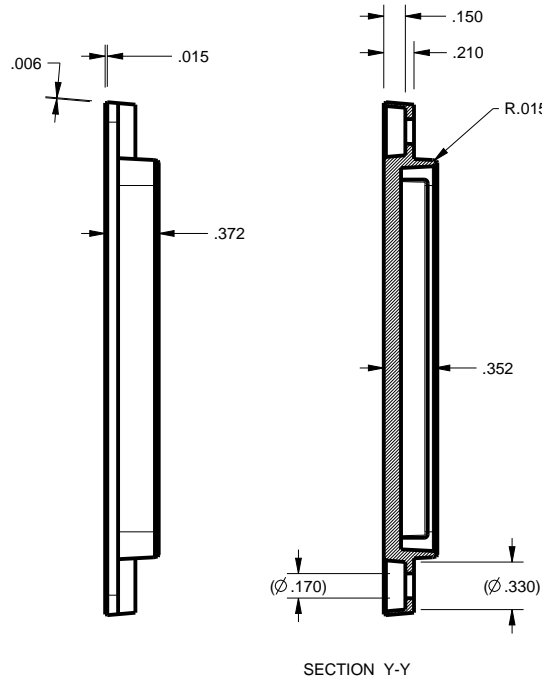
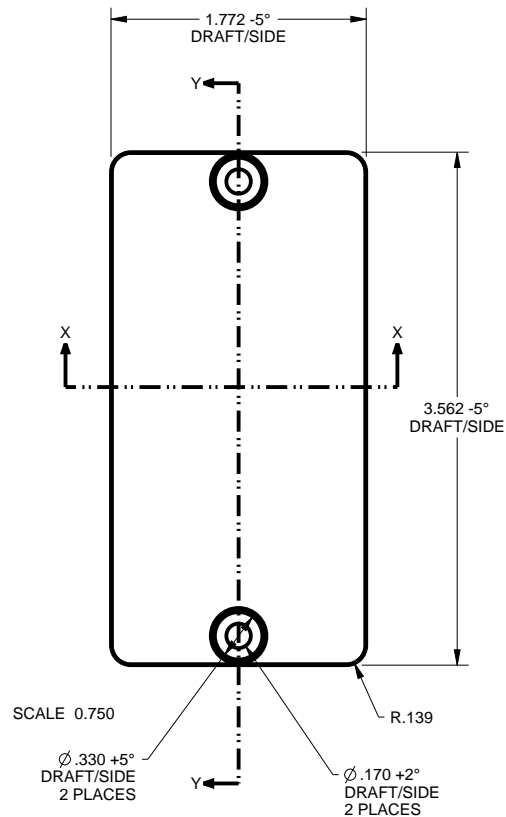

TOLERANCES: UNLESS OTHERWISE SPECIFIED DIMENSIONS ARE IN U.S. INCHES.	
X.XX = .015 X.XXXX = .001	
X.XXX = .010 X.X° = 1°	
NEW AGE ENCLOSURES	
Customer's Part No: 452715	
APPROVAL	BY DATE
CHECK	
ENG.	
SCALE	AS NOTED
DRAWN BY	SIZE
M BOYER	A
Sep-17-10	DRAWING NAME
	452715_R1_0
SHEET	REV.DOC
8 OF 11	1.0

NEW AGE ENCLOSURES
4330 Santa Fe Road San Luis Obispo, CA. 93401
ph. (805) 595-1310 fax (805) 595-1024
www.newageenclosures.com

**STAND - INDUSTRIAL UTIL
SLX-452715X-XXX**

452715 MAIN O-RING
FOR USE IN ALL CONFIGURATIONS

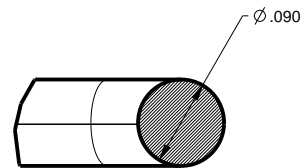
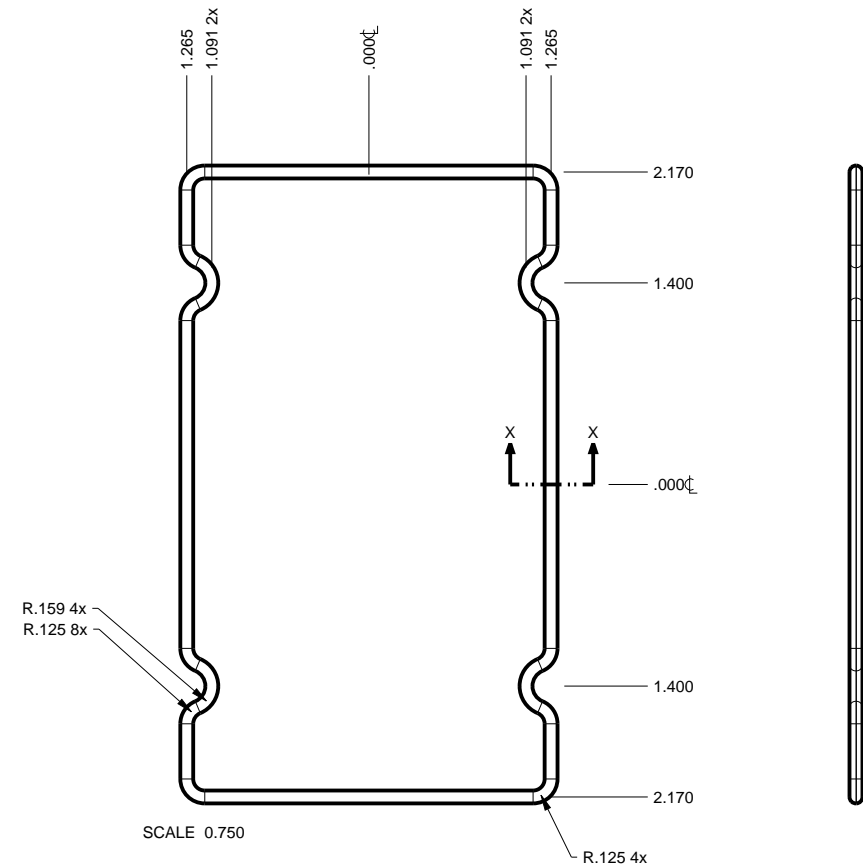

452715 BATTERY O-RING
FOR USE IN CONFIG: -BS -BW

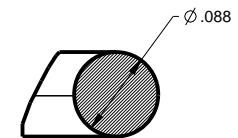
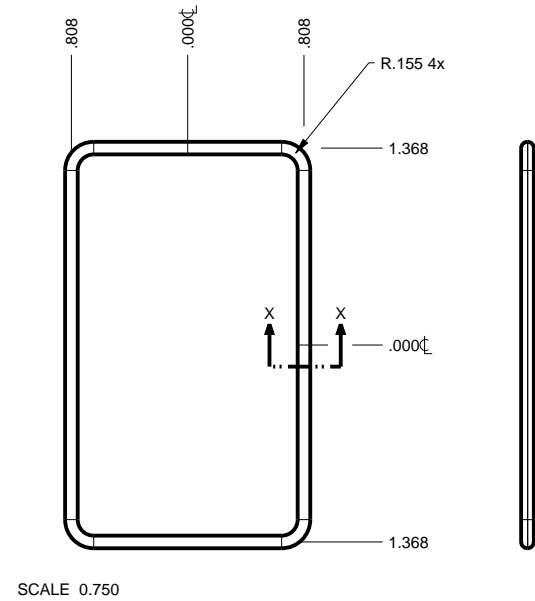

TOLERANCES: UNLESS OTHERWISE SPECIFIED DIMENSIONS ARE IN U.S. INCHES. X.XX = .015 X.XXXX = .001 X.XXX = .010 X.X° = 1°		NEW AGE ENCLOSURES	
Customer's Part No: 452715		4330 Santa Fe Road San Luis Obispo, CA. 93401 ph. (805) 595-1310 fax (805) 595-1024 www.newageenclosures.com	
APPROVAL	BY	DATE	STAND - INDUSTRIAL UTIL SLX-452715X-XXX
CHECK			
ENG.			
SCALE	AS NOTED		
DRAWN BY M BOYER	Sep-17-10	SIZE A	DRAWING NAME 452715_R1_0
		SHEET 9 OF 11	REV.DOC 1.0

452715 PCB - Customer Supplied

PCB SIZES ARE RECOMMENDATIONS ONLY. FINAL SIZES AND VERIFICATION OF IT'S FIT ARE THE SOLE RESPONSIBILITY OF THE OEM.

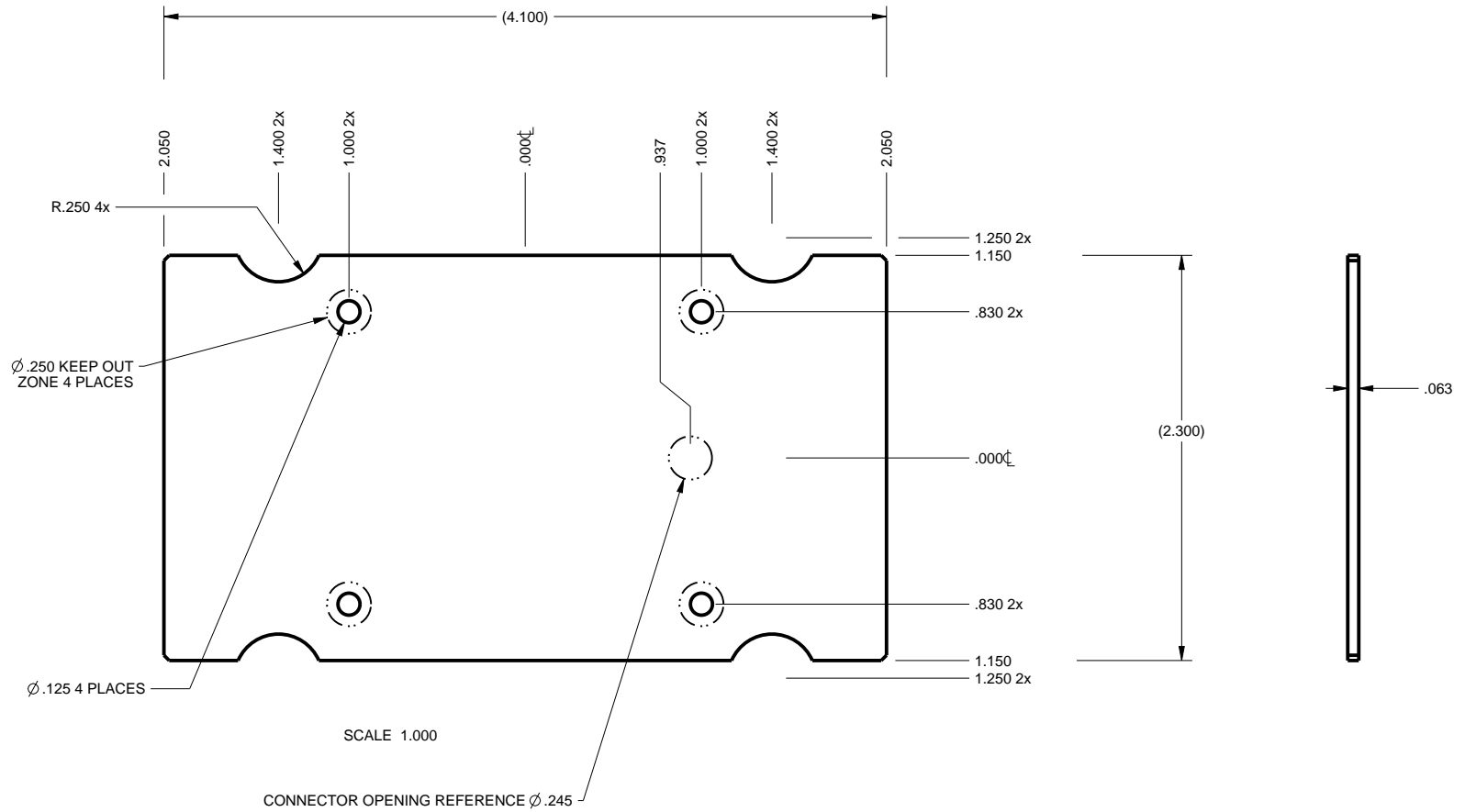

TOLERANCES: UNLESS OTHERWISE SPECIFIED
DIMENSIONS ARE IN U.S. INCHES.
X.XX = .015 X.XXXX = .001
X.XXX = .010 X.X° = 1°

NEW AGE ENCLOSURES

Customer's Part No: 452715

APPROVAL	BY	DATE
CHECK		
ENG.		
SCALE	AS NOTED	

SCALE AS NOTED

DRAWN BY M BOYER Sep-17-10

NEW AGE ENCLOSURES

4330 Santa Fe Road San Luis Obispo, CA. 93401
ph. (805) 595-1310 fax (805) 595-1024
www.newageenclosures.com

STAND - INDUSTRIAL UTIL
SLX-452715X-XXX

SIZE A DRAWING NAME 452715_R1_0

SHEET 10 OF 11 REV.DOC 1.0

452715 2nd OPERATION DETAILS

NEW AGE ENCLOSURES DELIVERS YOUR ENCLOSURE MARKET-READY WITH IN-HOUSE
 CNC MACHINING, PAD PRINTING, ASSEMBLY, AND FULFILLMENT.
 ALL SURFACES AND AREAS ARE AVAILABLE FOR CNC ALTERATION BY NEW AGE ENCLOSURES
 CALL (805) 595-1310 FOR PRICING AND SCHEDULE.
 THE INSIDE RADIUS OF ANY MACHINED FEATURES SHOULD BE NO SMALLER THAN .031"

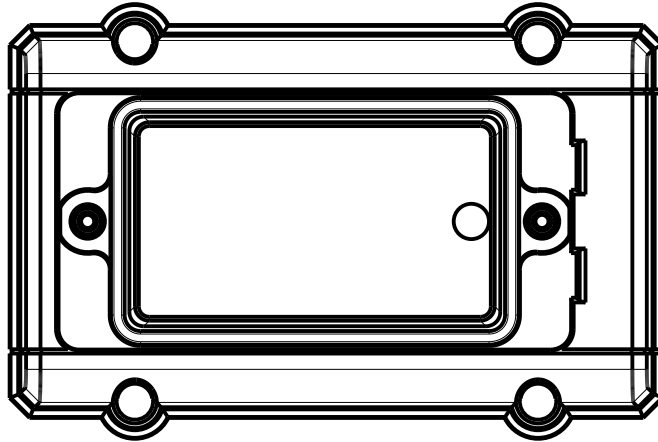

SCALE 0.750

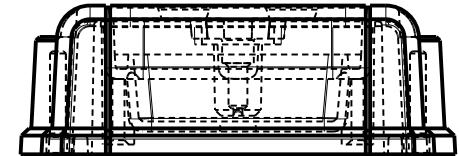
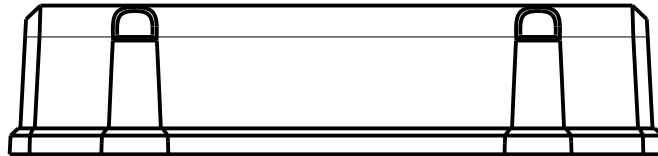

SLX-452715-XXX COVER - ASA, BLACK

STEP NO	DESCRIPTION	INK COLOR	CLICHE DESCRIPTION	CLICHE No.
1	PAD PRINT			

SLX-452715-XXX COVER - ASA, BLACK

STEP NO	DESCRIPTION	CUTTER	FIXTURE	ORIENTATION	PROGRAM
2		T2 = .062" EM			
3					
4					

TOLERANCES: UNLESS OTHERWISE SPECIFIED
 DIMENSIONS ARE IN U.S. INCHES.
 X.XX = .015 X.XXXX = .001
 X.XXX = .010 X.X° = 1°

NEW AGE ENCLOSURES

Customer's Part No: 452715

APPROVAL	BY	DATE
CHECK		
ENG.		
SCALE	AS NOTED	
DRAWN BY	M BOYER	
	Sep-17-10	

NEW AGE ENCLOSURES

4330 Santa Fe Road San Luis Obispo, CA. 93401
 ph. (805) 595-1310 fax (805) 595-1024

www.newageenclosures.com

STAND - INDUSTRIAL UTIL SLX-452715X-XXX

SIZE	DRAWING NAME	SHEET	REV.DOC
A	452715_R1_0	11 OF 11	1.0

Mouser Electronics

Authorized Distributor

Click to View Pricing, Inventory, Delivery & Lifecycle Information:

[New Age Enclosures:](#)

[S-452715-OR](#)

Компания «Life Electronics» занимается поставками электронных компонентов импортного и отечественного производства от производителей и со складов крупных дистрибьюторов Европы, Америки и Азии.

С конца 2013 года компания активно расширяет линейку поставок компонентов по направлению коаксиальный кабель, кварцевые генераторы и конденсаторы (керамические, пленочные, электролитические), за счёт заключения дистрибьюторских договоров

Мы предлагаем:

- Конкурентоспособные цены и скидки постоянным клиентам.
- Специальные условия для постоянных клиентов.
- Подбор аналогов.
- Поставку компонентов в любых объемах, удовлетворяющих вашим потребностям.
- Приемлемые сроки поставки, возможна ускоренная поставка.
- Доставку товара в любую точку России и стран СНГ.
- Комплексную поставку.
- Работу по проектам и поставку образцов.
- Формирование склада под заказчика.
- Сертификаты соответствия на поставляемую продукцию (по желанию клиента).
- Тестирование поставляемой продукции.
- Поставку компонентов, требующих военную и космическую приемку.
- Входной контроль качества.
- Наличие сертификата ISO.

В составе нашей компании организован Конструкторский отдел, призванный помогать разработчикам, и инженерам.

Конструкторский отдел помогает осуществить:

- Регистрацию проекта у производителя компонентов.
- Техническую поддержку проекта.
- Защиту от снятия компонента с производства.
- Оценку стоимости проекта по компонентам.
- Изготовление тестовой платы монтаж и пусконаладочные работы.



Тел: +7 (812) 336 43 04 (многоканальный)
Email: org@lifeelectronics.ru