

REVISIONS				
REV.	ECN	DESCRIPTION	DATE	APPROVED
A		PROPOSAL	APR 29.11	A.G
B		ADD THE THICKNESS DIM AND TRACE KEEP OUT AREA OF THE PCB	AUG 07.11	A.G
C		MODIFY THE DIMENSION BETWEEN PCB AND BEZEL	AUG 15.11	A.G
D		ADD 2X8 OPTION	JUL 04.12	J.SI

MATERIAL:

CAGE - PRESS FIT:
COPPER ALLOY

PLATING:
SEE AMPHENOL PART NUMBER
CONFIGURATION FOR OPTIONS.

CONNECTOR - PRESS FIT

PLASTIC HOUSING:
LIQUID CRYSTAL POLYMER (LCP),
FLAMMABILITY RATING UL94-0.

CONTACTS:
PHOSPHOR BRONZE
PLATING OPTION:
SEE AMPHENOL PART NUMBER
CONFIGURATION FOR OPTIONS.

PACKAGING:
TRAY PACKAGING.

TEMPERATURE RANGE:
-40°C TO +85°C

DATE CODE
PART NUMBER
(LAST DIGIT INDICATING
PACKAGING TYPE,
NOT PRINTED ON THE PART)

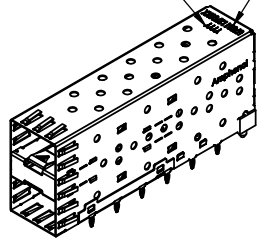

UE78-B1127-00XX1

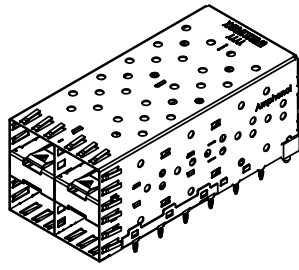

UE78-B2127-00XX1

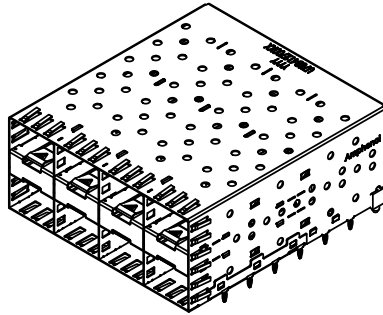

UE78-B4127-00XX1

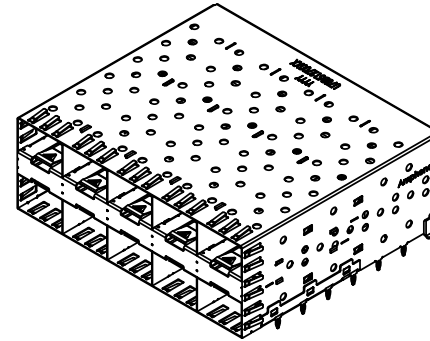

UE78-B5127-00XX1

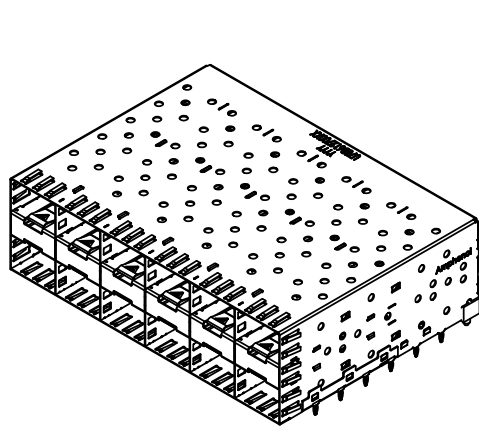

UE78-B6127-00XX1

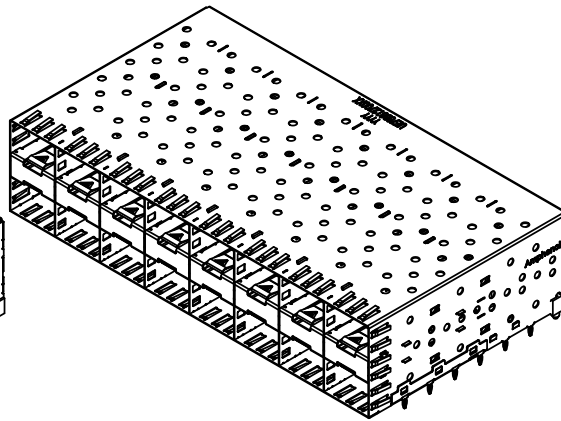

UE78-B8127-00XX1

AMPHENOL PART NUMBER CONFIGURATION

UE78-B X 1 27-00 X X 1

E=ROHS COMPLIANT

NUMBER OF PORTS

- 1 = 2X1
- 2 = 2X2
- 4 = 2X4
- 5 = 2X5
- 6 = 2X6
- 8 = 2X8

PACKAGING

- 1 = TRAY PACKAGING

CAGE PLATING

- 2 = NICKEL PLATING
- 3 = MATTE TIN PLATING

PRESS FIT CONNECTOR PLATING

- 3 = 30 μ" MIN. GOLD ON MATING AREA
- 150-300 μ" MATTE TIN ON TERMINATION
- 6 = 15 μ" MIN. GOLD ON MATING AREA
- 150-300 μ" MATTE TIN ON TERMINATION



DO NOT SCALE DRAWING

THIS DOCUMENT CONTAINS PROPRIETARY INFORMATION AND SUCH INFORMATION MAY NOT BE DISCLOSED TO OTHERS FOR ANY PURPOSE OR USED FOR MANUFACTURING PURPOSES WITHOUT PERMISSION FROM AMPHENOL CANADA CORP.

<small>UNLESS OTHERWISE SPECIFIED DIMENSIONS ARE IN MILLIMETERS TOLERANCES ARE:</small> DECIMALS: XX ± 0.25 X.XX ± 0.15 MATERIAL AND FINISH: N/A REF: X CODE IDENT. NO.: 03554	APPROVALS	DATE	Amphenol Canada Corp.	
	DRAWN: MIKE.H	APR 29.11		
	DESIGNED: J.SI	APR 29.11	SFF 2XN STACKED COMBO WITH DOUBLE BEND LATCH	
	CHECKED: J.SI	APR 29.11	GA APPD:	
	E APPD:		SIZE: A3	DWG. NO.: P-UE78-BX127-00XX1
	DWG APPD: A.GREEN	APR 29.11	SCALE: 2:1	PROJECT: SHEET 1 OF 4

REVISIONS

REV.	ECN	DESCRIPTION	DATE	APPROVED
A		PROPOSAL	APR 29.11	A.G
B		ADD THE THICKNESS DIM AND TRACE KEEP OUT AREA OF THE PCB	AUG 07.11	A.G
C		MODIFY THE DIMENSION BETWEEN PCB AND BEZEL	AUG 15.11	A.G
D		ADD 2XB OPTION	JUL 04.12	J.SI

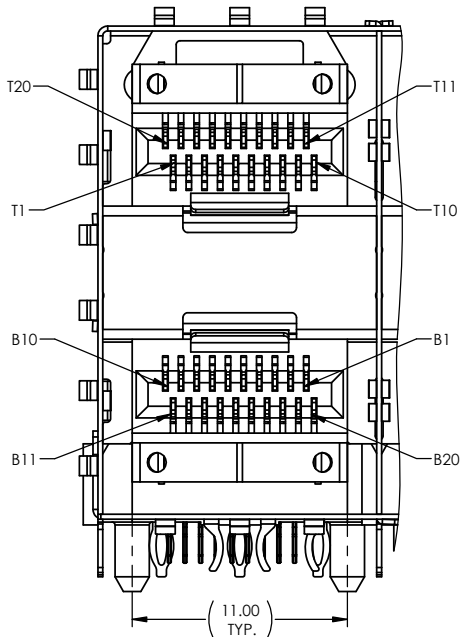
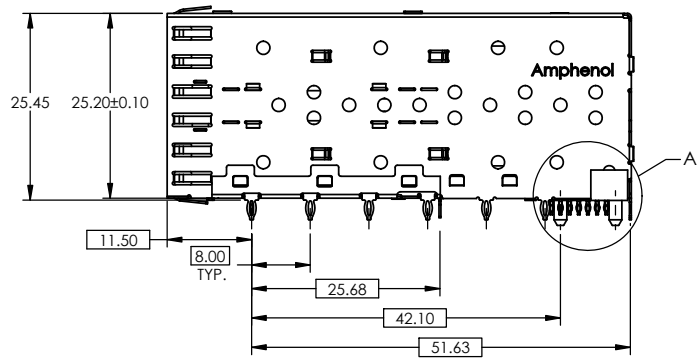
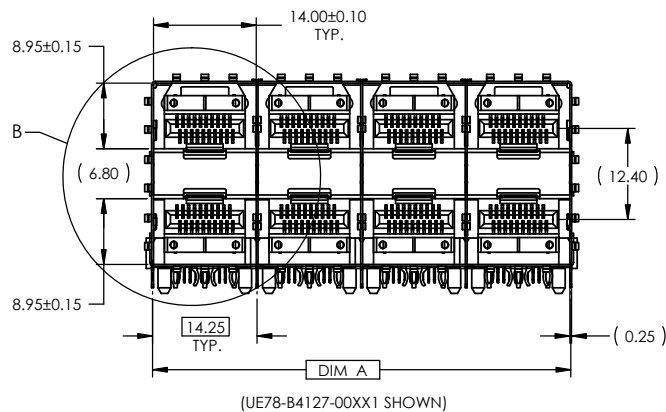

DETAIL B
SCALE 4 : 1
**TYPICAL PIN ASSIGNMENT
ON MATING AREA**

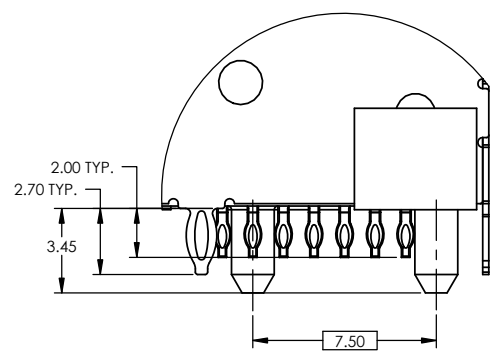

DETAIL A
SCALE 5 : 1

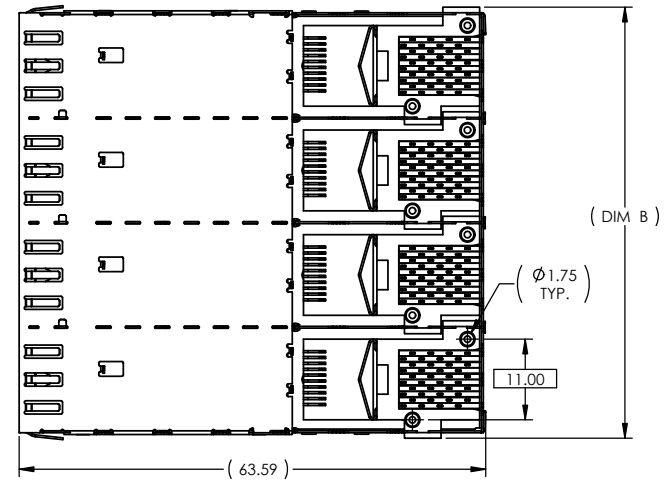

PART NUMBER	DIM A	DIM B
UE78-B1127-00XX1	14.25	16.00
UE78-B2127-00XX1	28.50	30.25
UE78-B4127-00XX1	57.00	58.75
UE78-B5127-00XX1	71.25	73.00
UE78-B6127-00XX1	85.50	87.25
UE78-B8127-00XX1	114.00	115.75

DO NOT SCALE DRAWING

THIS DOCUMENT CONTAINS PROPRIETARY INFORMATION AND SUCH INFORMATION MAY NOT BE DISCLOSED TO OTHERS FOR ANY PURPOSE OR USED FOR MANUFACTURING PURPOSES WITHOUT PERMISSION FROM AMPHENOL CANADA CORP.

UNLESS OTHERWISE SPECIFIED DIMENSIONS ARE IN MILLIMETERS TOLERANCES ARE:		APPROVALS		DATE		Amphenol Canada Corp.	
DECIMALS X.X ± 0.25 X.XX ± 0.15	ANGLES ± 1°	DRAWN MIKE.H	APR 29.11	DESIGNED J.SI	APR 29.11		
MATERIAL AND FINISH N/A		CHECKED J.SI	APR 29.11	GA APPD		TITLE	
REF. X	E APPD	DWG. NO. P-UE78-BX127-00XX1		REV. D	SIZE A3		DWG. NO.
CODE IDENT. NO. 03554	DWG APPD A.GREEN	APR 29.11	SCALE 2:1	PROJECT	SHEET 2 OF 4		

REVISIONS				
REV.	ECN	DESCRIPTION	DATE	APPROVED
A		PROPOSAL	APR 29.11	A.G
B		ADD THE THICKNESS DIM AND TRACE KEEP OUT AREA OF THE PCB	AUG 07.11	A.G
C		MODIFY THE DIMENSION FROM PCB AND BEZEL	AUG 15.11	A.G
D		ADD 2X8 OPTION	JUL 04.12	J.SI

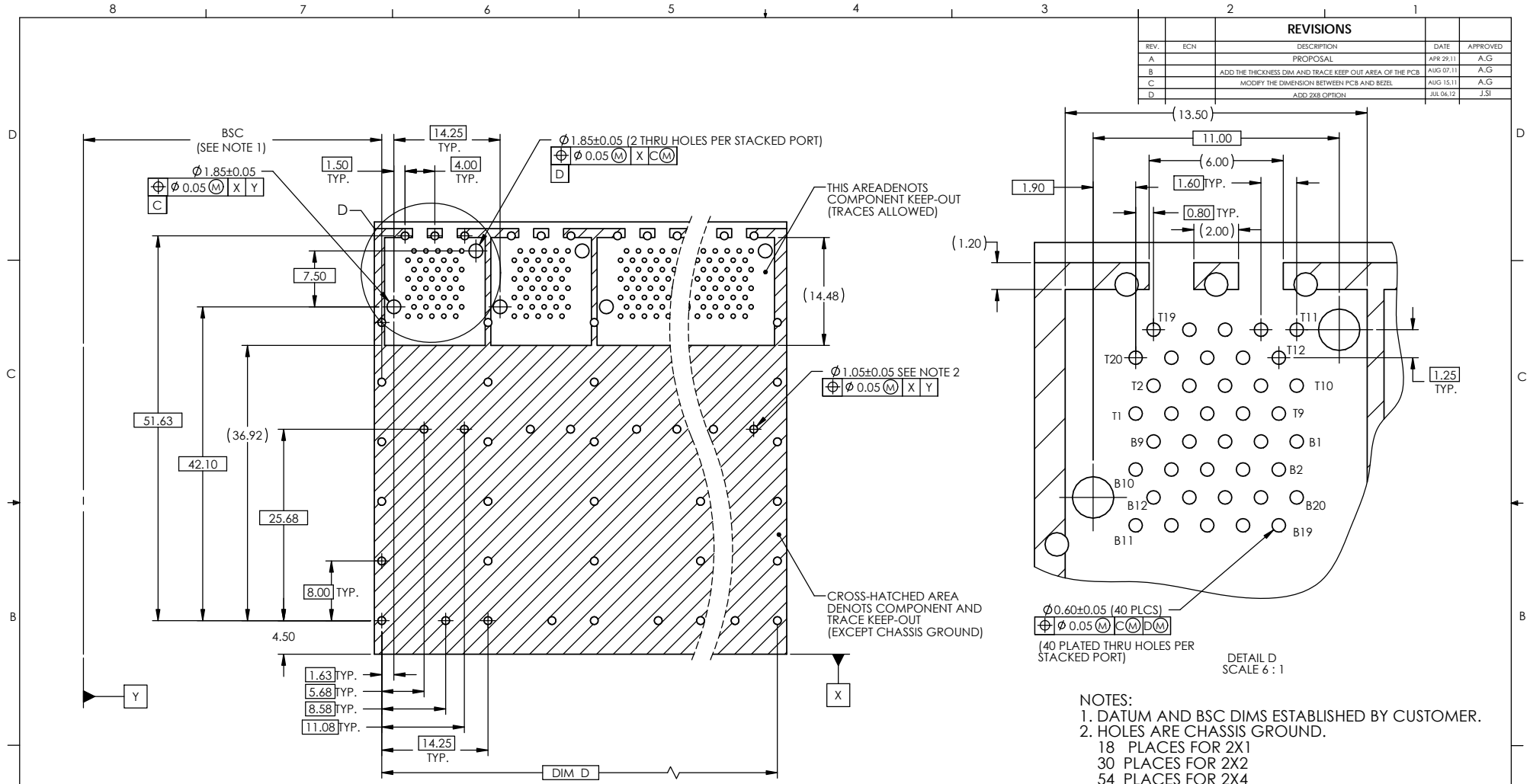

**RECOMMENDED SFP HOST BOARD LAYOUT
(ONE SIDE CAGE MOUNTING)**

DO NOT SCALE DRAWING

THIS DOCUMENT CONTAINS PROPRIETARY INFORMATION AND SUCH INFORMATION MAY NOT BE DISCLOSED TO OTHERS FOR ANY PURPOSE OR USED FOR MANUFACTURING PURPOSES WITHOUT PERMISSION FROM AMPHENOL CANADA CORP.

PART NUMBER	DIM D
UE78-B1127-00XX1	14.25
UE78-B2127-00XX1	28.50
UE78-B4127-00XX1	57.00
UE78-B5127-00XX1	71.25
UE78-B6127-00XX1	85.50
UE78-B8127-00XX1	114.00

UNLESS OTHERWISE SPECIFIED DIMENSIONS ARE IN MILLIMETERS TOLERANCES ARE:
 DECIMALS ANGLES
 X.X ± 0.25 ± 1°
 X.XX ± 0.15
 MATERIAL AND FINISH
 N/A

APPROVALS	DATE
DRAWN MIKE.H	APR 29.11
DESIGNED J.SI	APR 29.11
CHECKED J.SI	APR 29.11
QA APPD	
E APPD	
DWG APPD A.GREEN	APR 29.11

Amphenol Canada Corp.
 TITLE
SFP 2XN STACKED COMBO WITH DOUBLE BEND LATCH

REF.	CODE IDENT. NO.	SIZE	DWG. NO.	SCALE	PROJECT	SHEET
X	03554	A3	P-UE78-BX127-00XX1	2:1		3 OF 4

REVISIONS				
REV.	ECN	DESCRIPTION	DATE	APPROVED
A		PROPOSAL	APR 29.11	A.G
B		ADD THE THICKNESS DIM AND TRACE KEEP OUT AREA OF THE PCB	AUG 07.11	A.G
C		MODIFY THE DIMENSION BETWEEN PCB AND BEZEL	AUG 15.11	A.G
D		ADD 2X8 OPTION	JUL 06.12	J.SI

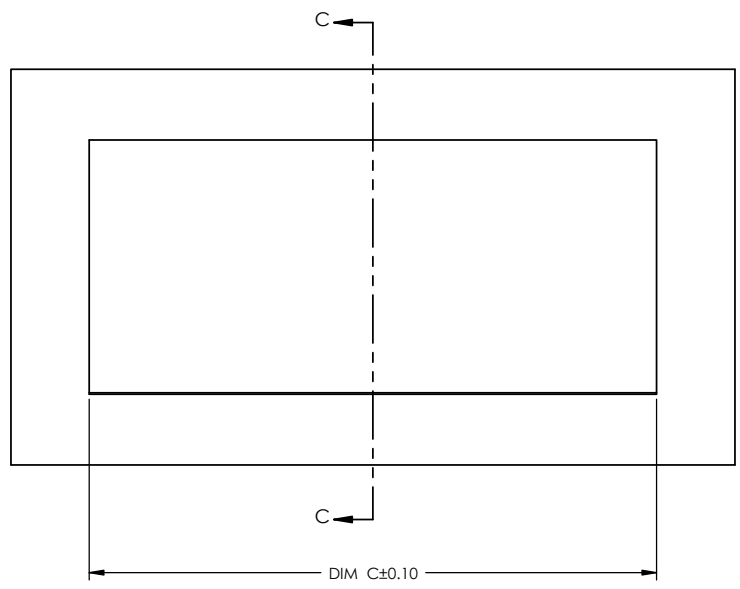

RECOMMENDED BEZEL DESIGN

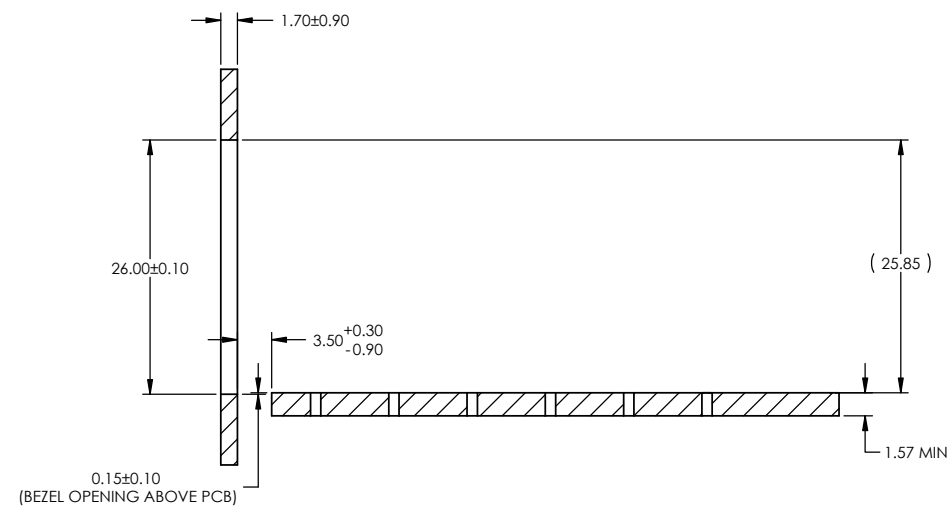

SECTION C-C
SCALE 2:1

PART NUMBER	DIM C
UE78-B1127-00XX1	15.25
UE78-B2127-00XX1	29.50
UE78-B4127-00XX1	58.00
UE78-B5127-00XX1	72.25
UE78-B6127-00XX1	86.50
UE78-B8127-00XX1	115.00

UNLESS OTHERWISE SPECIFIED DIMENSIONS ARE IN MILLIMETERS TOLERANCES ARE:		APPROVALS		DATE	Amphenol Canada Corp.	
DECIMALS	ANGLES	DRAWN	MIKE.H	APR 29.11	TITLE SFP 2XN STACKED COMBO WITH DOUBLE BEND LATCH	
X.X ± 0.25	± 1°	DESIGNED	J.SI	APR 29.11		
X.XX ± 0.15		CHECKED	J.SI	APR 29.11		
MATERIAL AND FINISH		QA APPD				
REF.		E APPD			SIZE	DWG. NO.
X					A3	P-UE78-BX127-00XX1
CODE IDENT. NO.	03554	DWG APPD	A.GREEN	APR 29.11	SCALE	PROJECT
					2:1	
						REV.
						D
						SHEET
						4 OF 4

DO NOT SCALE DRAWING

THIS DOCUMENT CONTAINS PROPRIETARY INFORMATION AND SUCH INFORMATION MAY NOT BE DISCLOSED TO OTHERS FOR ANY PURPOSE OR USED FOR MANUFACTURING PURPOSES WITHOUT PERMISSION FROM AMPHENOL CANADA CORP.

Компания «Life Electronics» занимается поставками электронных компонентов импортного и отечественного производства от производителей и со складов крупных дистрибьюторов Европы, Америки и Азии.

С конца 2013 года компания активно расширяет линейку поставок компонентов по направлению коаксиальный кабель, кварцевые генераторы и конденсаторы (керамические, пленочные, электролитические), за счёт заключения дистрибьюторских договоров

Мы предлагаем:

- Конкурентоспособные цены и скидки постоянным клиентам.
- Специальные условия для постоянных клиентов.
- Подбор аналогов.
- Поставку компонентов в любых объемах, удовлетворяющих вашим потребностям.
- Приемлемые сроки поставки, возможна ускоренная поставка.
- Доставку товара в любую точку России и стран СНГ.
- Комплексную поставку.
- Работу по проектам и поставку образцов.
- Формирование склада под заказчика.
- Сертификаты соответствия на поставляемую продукцию (по желанию клиента).
- Тестирование поставляемой продукции.
- Поставку компонентов, требующих военную и космическую приемку.
- Входной контроль качества.
- Наличие сертификата ISO.

В составе нашей компании организован Конструкторский отдел, призванный помогать разработчикам, и инженерам.

Конструкторский отдел помогает осуществить:

- Регистрацию проекта у производителя компонентов.
- Техническую поддержку проекта.
- Защиту от снятия компонента с производства.
- Оценку стоимости проекта по компонентам.
- Изготовление тестовой платы монтаж и пусконаладочные работы.



Тел: +7 (812) 336 43 04 (многоканальный)

Email: org@lifeelectronics.ru