



The Future of Analog IC Technology®

# MP2604

## Single-Cell 1A Linear Li-Ion Battery Charger without Trickle Charge

### DESCRIPTION

The MP2604 is a linear, high-performance single cell Li-Ion battery charger. By integrating high voltage input protection into the charger IC, the MP2604 can tolerate an input surge up to 28V.

The device features constant current (CC) and constant voltage (CV) charging modes with programmable charge currents (85mA to 1A), programmable battery full threshold, thermal protection, battery temperature monitoring and reverse current blocking. The device also provides AC adapter power good and charge status indications to the system.

MP2604 is available in 10-pin 3mm x 3mm QFN package.

### EVALUATION BOARD REFERENCE

Board Number	Dimensions
EV2604DQ-00A	2.0" x 1.9" x 0.6"

### FEATURES

- Input Surge up to 28V
- Adapter or USB Input
- Programmable Charge Current: 85mA to 1A
- Proprietary Constant Voltage Auto Recharge
- Proprietary Over-Voltage Protection
- 0.75%  $V_{BATT}$  Accuracy
- $<1\mu A$  Battery Reverse Current
- 90 $\mu A$  Standby Current from  $V_{IN}$
- Battery Temperature Monitoring
- Over Current Protection
- AC Adapter Power Good Indicator
- Charge Status Indicator
- Programmable Soft-Start
- Programmable Charge Termination Current Threshold
- Tiny 3mm x 3mm QFN Package

### APPLICATIONS

- Cell Phones
- MP3/Multimedia Players
- Smart Phones
- PDAs
- Digital Cameras

"MPS" and "The Future of Analog IC Technology" are Registered Trademarks of Monolithic Power Systems, Inc.

### TYPICAL APPLICATION

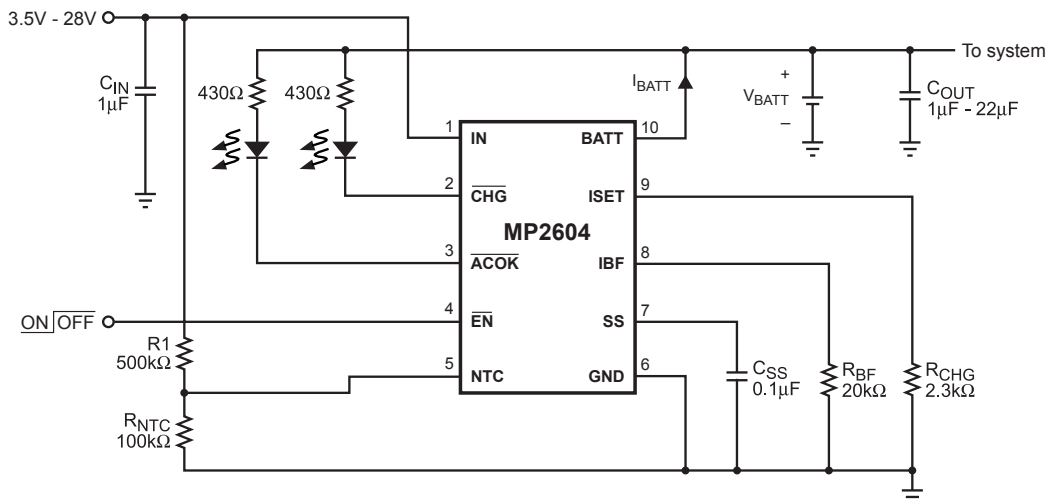

**PACKAGE REFERENCE**

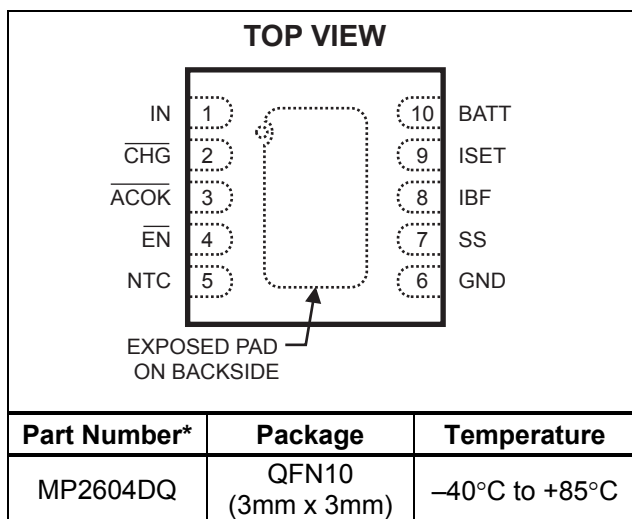

\* For Tape & Reel, add suffix -Z (eg. MP2604DQ-Z)  
 For RoHS Compliant Packaging, add suffix -LF  
 (eg. MP2604DQ-LF-Z)

**ABSOLUTE MAXIMUM RATINGS <sup>(1)</sup>**

IN to GND ..... -0.3V to +28V  
 All Other Pins to GND ..... -0.3V to +6.5V  
 Junction Temperature ..... 140°C  
 Lead Temperature ..... 260°C  
 Storage Temperature ..... -65°C to +150°C

**Recommended Operating Conditions <sup>(2)</sup>**

Nominal Supply Voltage  $V_{IN}$  ..... 3.5V to 6.5V  
 Operating Temperature ..... -40°C to +85°C

**Thermal Resistance <sup>(3)</sup>**       $\theta_{JA}$        $\theta_{JC}$   
 3x3 QFN10 ..... 50 ..... 12... °C/W

**Notes:**

- 1) Exceeding these ratings may damage the device.
- 2) The device is not guaranteed to function outside of its operating conditions.
- 3) Measured on approximately 1" square of 1 oz copper.

**ELECTRICAL CHARACTERISTICS**

$V_{IN} = 5V$ ,  $V_{EN} = 0V$ ,  $T_A = +25°C$ , unless otherwise noted.

Parameter	Symbol	Condition	Min	Typ	Max	Units
Supply Current	$I_{SUPPLY}$	$\overline{EN} = \text{High}$		40		$\mu A$
		$\overline{EN} = \text{Low}, I_{CHG} = 0A$		500		
Battery Voltage Regulation	$V_{BATT}$	$T = -5°C \text{ to } +75°C, I_{BATT} = 0$	4.158	4.20	4.242	V
Battery Over-Voltage Protection	$I_{BATT\_OVP}$	$V_{BATT} = 4.25V$			0	$\mu A$
Constant Current Regulation	$I_{CHG}$	$V_{IN} = 5V, V_{BATT} = 3.8V$ $R_{CHG} = 3.3k\Omega$	450	515	580	mA
Constant Current Variation		$V_{IN} = 5V, V_{BATT} = 3.8V,$ $T_J = 0°C \text{ to } +120°C,$ $R_{CHG} = 1.6k\Omega \text{ to } 8.0k\Omega$	87	100	113	$\%I_{CHG}^{(4)}$
Battery Full Programming Range	$I_{BF}$	Refer to Operation section for programming $I_{BF}$	10		50	$\%I_{CHG}^{(4)}$
IBF Accuracy			75		125	$\%I_{BF}^{(5)}$
SS Pin Voltage		$C_{SS} = 0.1\mu F, V_{BATT} = 3.6V$	1.19	1.23	1.27	V
Input $\overline{ACOK}$ Up Range			6.8	7.0	7.2	V
Input $\overline{ACOK}$ Low Range			1.8	2.5	3.2	V
$\overline{EN}$ Trip Threshold High			2.5			V
$\overline{EN}$ Trip Threshold Low					0.4	V
Input Over Voltage Protection	OVP	$V_{IN}$ Rising	6.7	7	7.3	V

**ELECTRICAL CHARACTERISTICS** (continued)

V<sub>IN</sub> = 5V, V<sub>EN</sub> = 0V, T<sub>A</sub> = +25°C, unless otherwise noted.

Parameter	Symbol	Condition	Min	Typ	Max	Units
OVP Hysteresis				400		mV
$\overline{\text{CHG}}$ , $\overline{\text{ACOK}}$ Sink Current		Pin Voltage = 0.4V	8			mA
Battery Reverse Current to BATT Pin		$\overline{\text{EN}}$ = Low and Input = Floating or 0V			1	μA
Switch-On Resistance	R <sub>ON</sub>	V <sub>BATT</sub> = 3.8V, I <sub>BATT</sub> = 300mA, R <sub>CHG</sub> = 1.7kΩ		0.35		Ω
Soft Thermal Shutdown Threshold			105	120	135	°C
Soft Thermal Shutdown Hysteresis				10		°C
Soft-Start Time		C <sub>SS</sub> = 0.1μF	10	20	35	ms

**Notes:**

- 4) I<sub>CHG</sub> is the target preprogrammed charge current (Die temperature below 110°C).
- 5) I<sub>BF</sub> is the target preprogrammed battery full current threshold.

**PIN FUNCTIONS**

Pin #	Name	Description
1	IN	Input Supply Pin. IN receives the AC adapter or USB supply voltage.
2	$\overline{\text{CHG}}$	Open-Drain Charge Status Indicator. This pin is low during charging.
3	$\overline{\text{ACOK}}$	Open-Drain Input ACOK Indicator. This pin is low if the voltage at the IN pin is between 2.5V and 6V.
4	$\overline{\text{EN}}$	Charger IC Enable. An input “Low” signal at this pin or if the pin is floating will enable the IC.
5	NTC	Negative Thermal Coefficient (NTC) Thermistor Pin. Connect a 500kΩ resistor from this pin to the IN pin and a 100kΩ NTC resistor (within the battery pack) from this pin to ground. If the NTC function is not used, replace the NTC resistor with a regular 100kΩ resistor from this pin to ground. <b>Do not leave this pin floating.</b>
6	GND	Ground.
7	SS	Soft-Start Timer. Connect this pin to an external capacitor to program the soft-start startup time using the equation: $T_{SS} = \frac{C_{SS}}{0.1\mu\text{F}} \times 20\text{m sec.}$
8	IBF	Charge Status Threshold Program. Connect this pin to an external resistor to program the charge termination current or battery full charge current.
9	ISET	Constant Charge Current Program. Connect this pin to an external resistor to program the charging current in CC Mode.
10	BATT	Charger Output.

**TYPICAL PERFORMANCE CHARACTERISTICS**

$V_{IN} = 5V$ ,  $C_{IN} = 10\mu F$ ,  $C_{OUT} = 4.7\mu F$ ,  $T_A = +25^\circ C$ , unless otherwise noted.

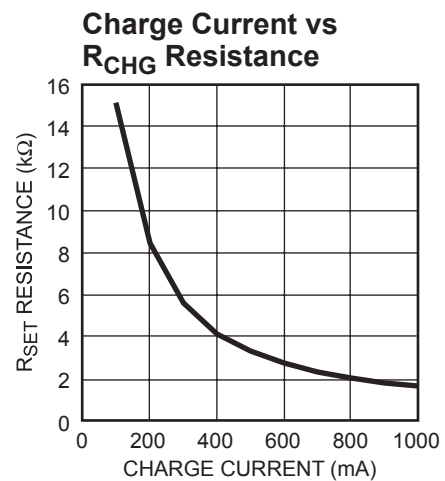
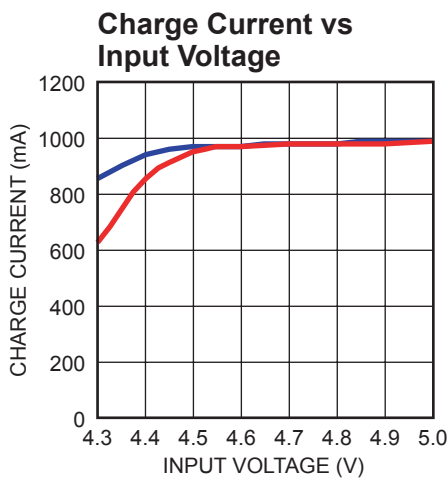
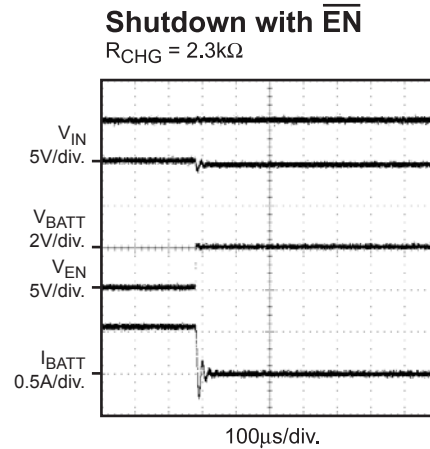
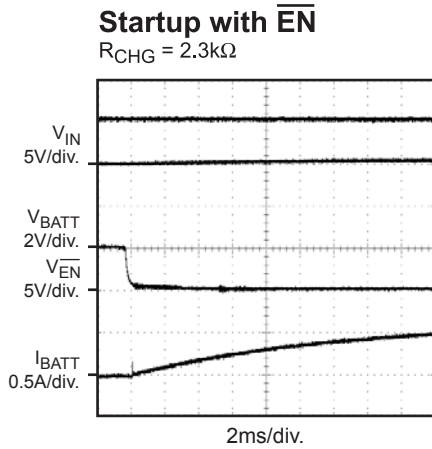
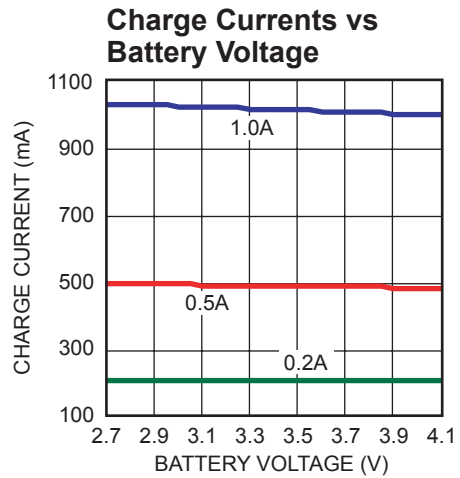
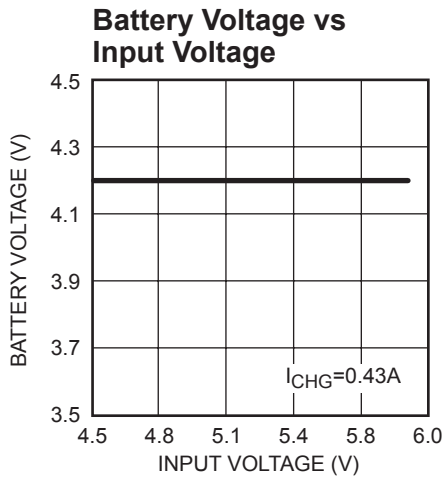

**TYPICAL PERFORMANCE CHARACTERISTICS** (continued)

$V_{IN} = 5V$ ,  $C_{IN} = 10\mu F$ ,  $C_{OUT} = 4.7\mu F$ ,  $T_A = +25^\circ C$ , unless otherwise noted.

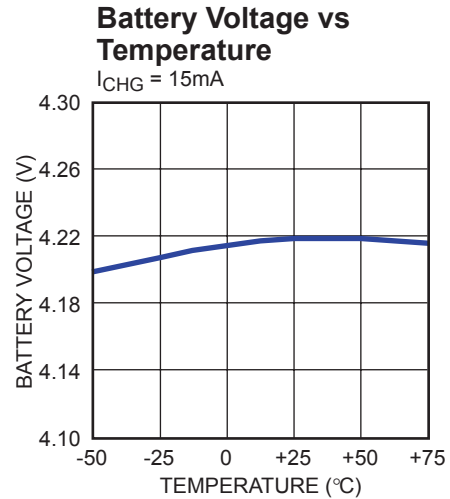
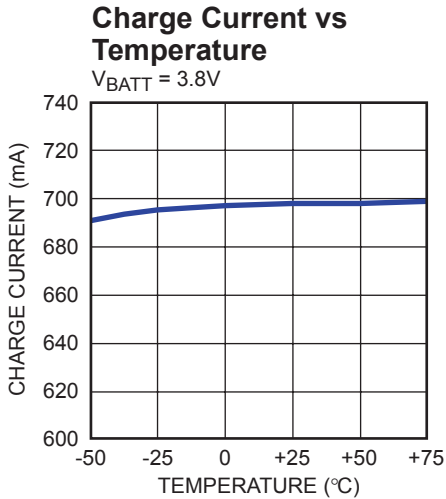
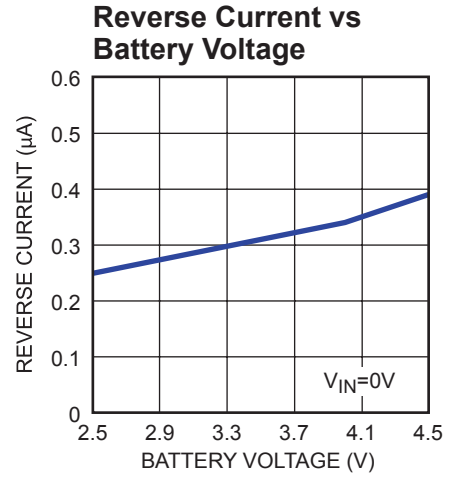
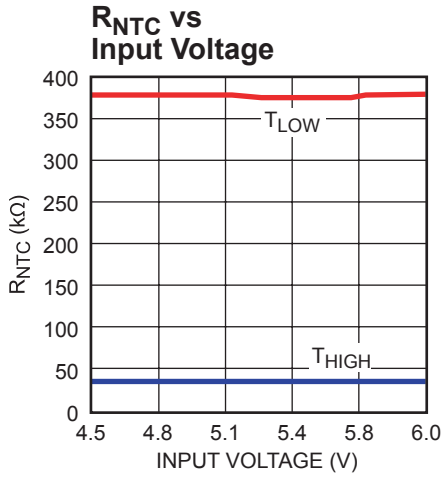

## BLOCK DIAGRAM

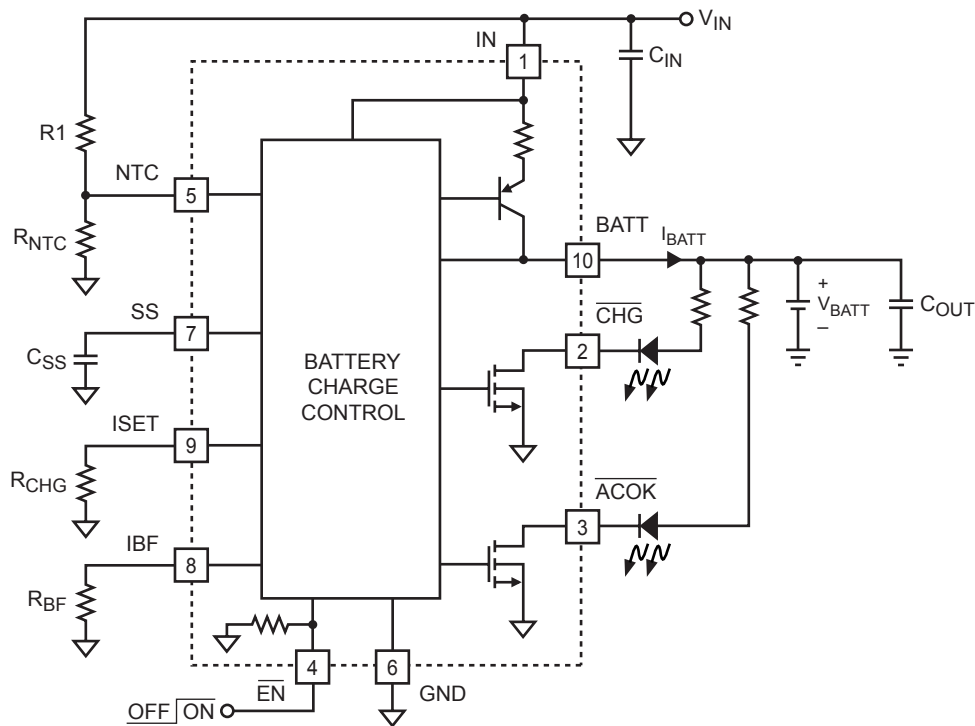

**Figure 1—Functional Block Diagram**

## OPERATION

### Input Voltage Range

The MP2604 has built-in input voltage surge protection as high as +28V. The charger IC will be automatically disabled when the input voltage is lower than 2.5V or higher than 7.0V. The open-drain pin  $\overline{\text{ACOK}}$  is used to indicate an input power good condition (i.e.  $2.5\text{V} < V_{\text{IN}} < 7.0\text{V}$ ). If the input voltage is lower than the battery voltage, the IC is also disabled to prevent the battery from draining.

### Charge Cycle (Mode Change: CC-> CV)

Figure 2 below shows the typical charging profile for the MP2604. Figure 3 shows the typical charging procedure. For a depleted battery the MP2604 will start with the constant current of the programmed value ( $I_{\text{CHG}}$ ). This is referred to as Constant Current (CC) mode. Once the battery voltage reaches 4.2V, the charger will operate in the constant voltage (CV) mode until the battery is fully charged. The charge current drops during CV mode, and the battery full indication is set when the charge current in the CV mode is reduced to the programmed full battery current ( $I_{\text{BF}}$ ).

The MP2604 can start up with heavy load and is stable without a battery connected to the BATT pin.

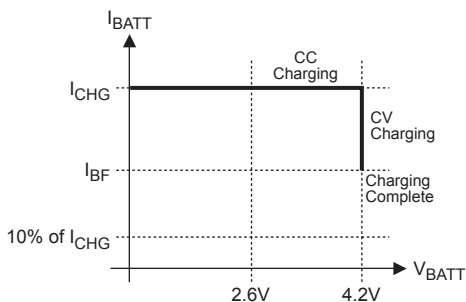

**Figure 2—MP2604 Typical Charging Profile**

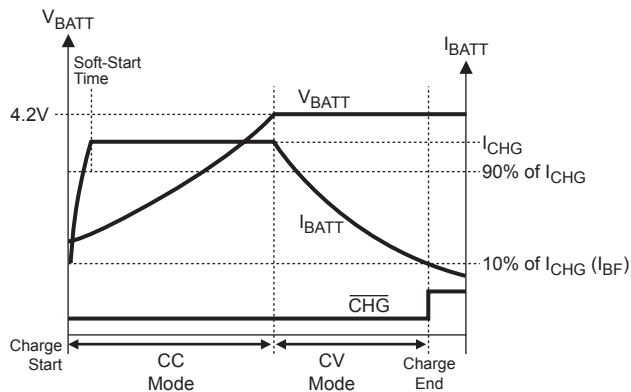

**Figure 3—MP2604 Typical Charging Procedure**

**Battery Over-Voltage Protection and Automatic Recharge**

At any time when  $V_{BATT}$  is 50mV higher than the trimmed charge target, the MP2604 reduces its charge current to 0 $\mu$ A. This ensures the safety of the battery. Also, the CV control loop always monitors the battery voltage such that it will automatically recharge the battery when it is depleted below the target level.

**Programming of Charge Current and Battery Full Current**

The charge current ( $I_{CHG}$ ) is set by a resistor ( $R_{CHG}$ ) connecting from the ISET pin to GND. The relationship of the charge current and the programming resistance is established by the following table and graph.

**Table 1— $R_{PGM}$  and  $I_{CHG}$  Relationship**

$R_{CHG}$ (k $\Omega$ )	$I_{CHG}$ (mA)
1.65	1000
1.82	900
2.05	800
2.32	700
2.74	600
3.3	500
4.12	400
5.6	300
8.45	200
15	100

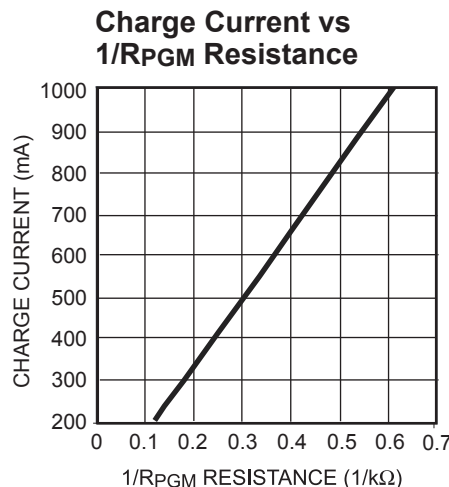

**Figure 4—Charge Current vs  $1/R_{PGM}$  Resistance**

The recommended resistance for programming the charge current is  $2.3k\Omega < R_{CHG} < 11k\Omega$ . The battery full charge current threshold ( $I_{BF}$ ) is programmed by connecting a resistor  $R_{BF}$  from the IBF pin to GND:

$$I_{BF} = \frac{1A \times 1.7k\Omega}{R_{BF}}$$

Where  $2R_{CHG} < R_{BF} < 10R_{CHG}$ . The open-drain pin  $\overline{CHG}$  is used to indicate charging status. When the battery full condition is reached or any other condition prevents the charger from charging,  $\overline{CHG}$  will become a floating pin.

**Charge Status Indicator ( $\overline{\text{CHG}}$ )**

The MP2604 has an integrated charge status pin that remains low while the battery is charging. Once the charge current has reduced to the battery full charge current threshold ( $I_{\text{BF}}$ ), the  $\overline{\text{CHG}}$  pin will become high impedance.

Under full charge conditions, certain systems may draw a very narrow current pulse that exceeds the  $I_{\text{BF}}$  threshold. The  $\overline{\text{CHG}}$  indicator may glitch. It is desirable to blank the  $\overline{\text{CHG}}$  glitch so that the system can properly indicate full charge conditions to the end user. A simple solution is to add a RC filter on the  $\overline{\text{CHG}}$  pin to filter out the possible  $\overline{\text{CHG}}$  glitch, as shown in Figure 5.

**Negative Thermal Coefficient (NTC) Thermistor**

The MP2604 has a built-in NTC resistance window comparator. If configured as the typical application circuit as indicated in Figure 1, the MP2604 will cease charging if  $R_{\text{NTC}} < 32.3\text{k}\Omega$  or  $R_{\text{NTC}} > 376.6\text{k}\Omega$ . This represents a valid charging temperature range of  $0^\circ\text{C}$  to  $50^\circ\text{C}$  for the TH11-4H104F NTC resistor including threshold vs. input voltage.

**Thermal Protection**

The MP2604 has proprietary thermal protection to prevent the IC from overheating. When in thermal protection mode, the charge current becomes a saw-tooth waveform instead of a DC current. The average current of the saw-tooth waveform will be lower than the programmed DC charge current to prevent the IC from overheating. The frequency and amplitude of the saw-tooth current waveform can be altered by changing the capacitance value connected to the SS pin. Operating in thermal protection mode will slow down the charging process. Lowering the input voltage and enhancing thermal dissipation to the environment can effectively prevent the IC from going into thermal protection mode.

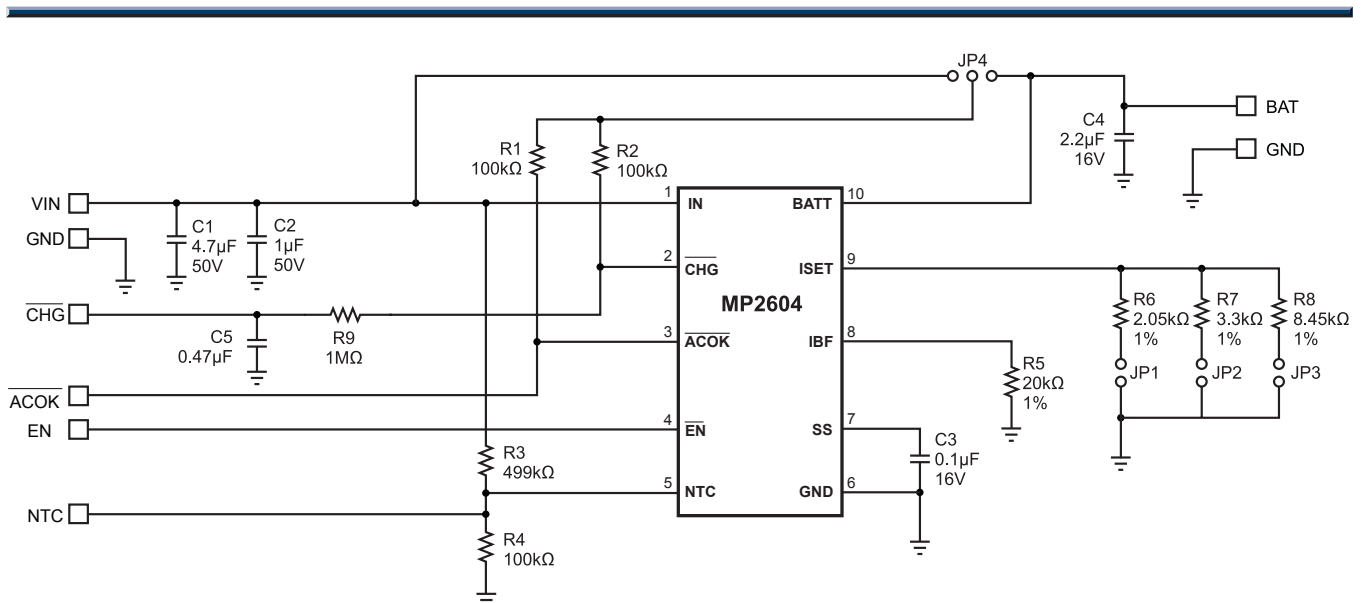

**Figure 5—Filtered Charge Status with GPIO Connection**



## APPLICATION

### Flow Chart of Operation

Power-On Reset (POR) feature can be applied to the MP2604 to ensure that the device starts operating in a known state. The flow chart in Figure 5 describes the conditions and operation

modes of the MP2604. CVC and CCC stand for “constant voltage charge” and “constant current charge”, respectively.

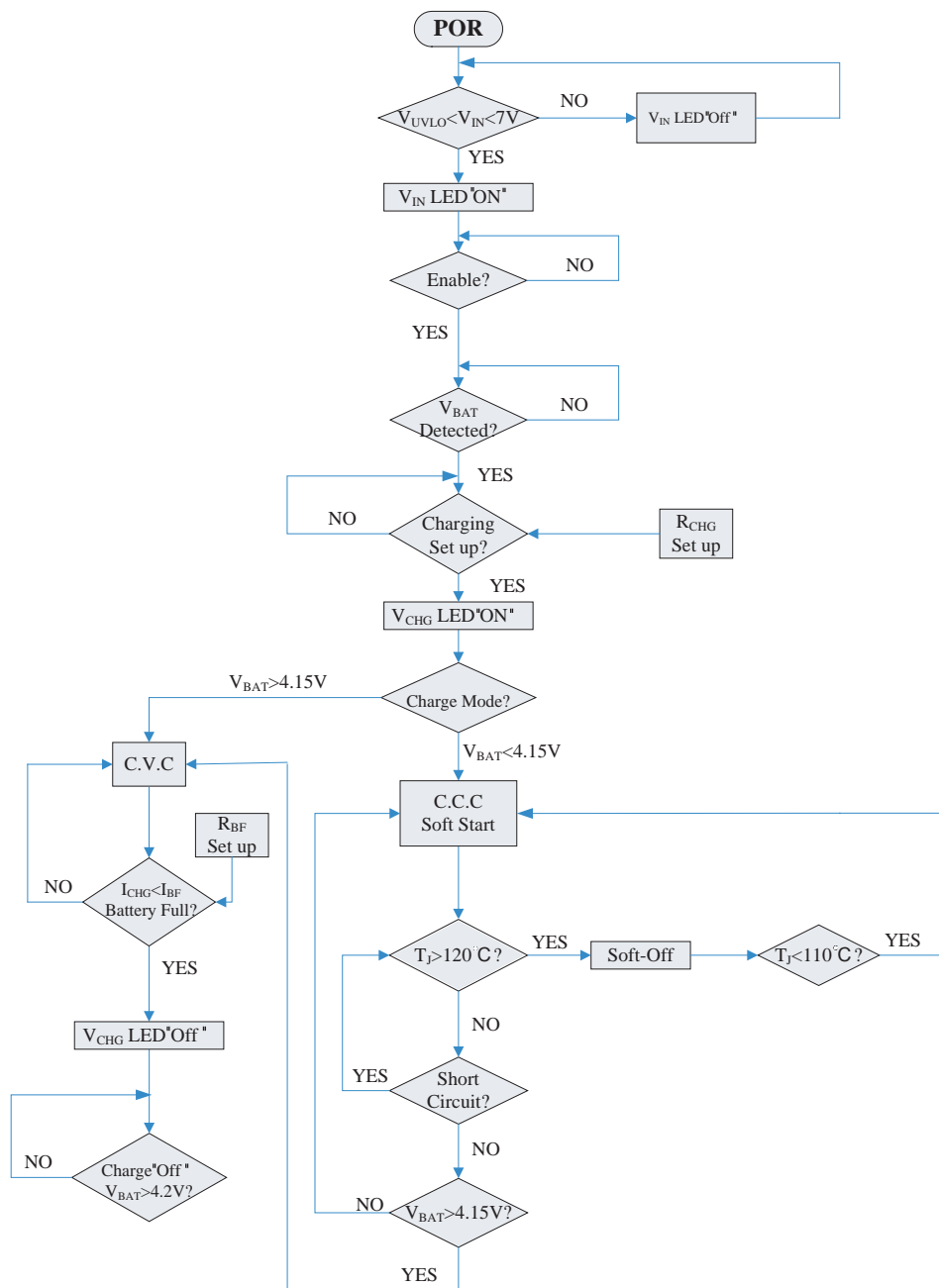

**Figure 6—Flow Chart of Operation**

**PACKAGE INFORMATION**

**QFN10 (3mm x 3mm)**

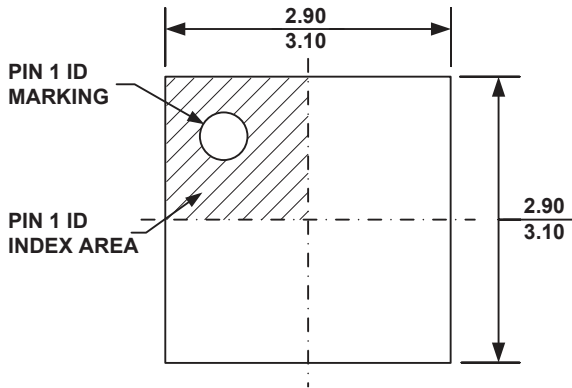

**TOP VIEW**

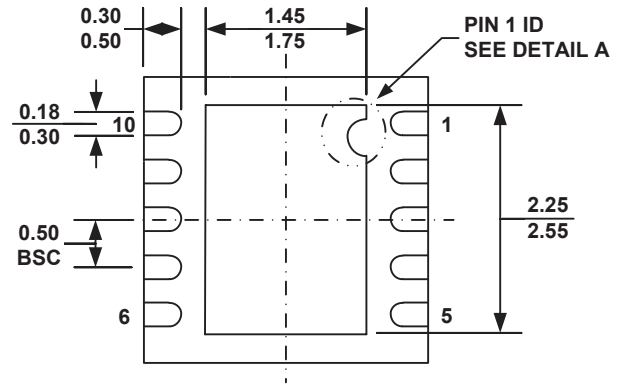

**BOTTOM VIEW**

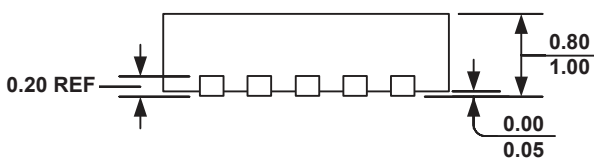

**SIDE VIEW**

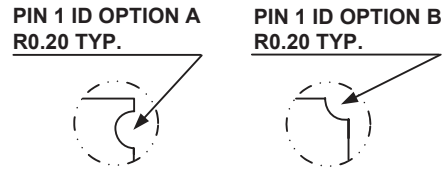

**DETAIL A**

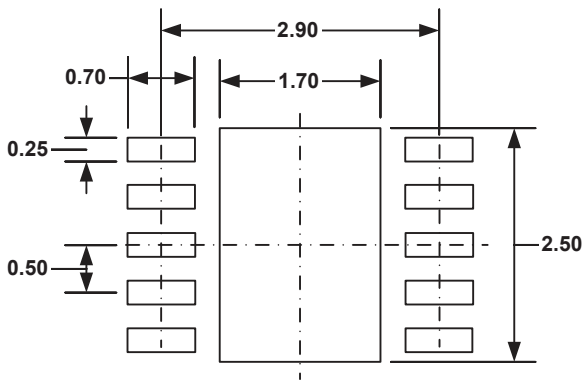

**RECOMMENDED LAND PATTERN**

**NOTE:**

- 1) ALL DIMENSIONS ARE IN MILLIMETERS.
- 2) EXPOSED PADDLE SIZE DOES NOT INCLUDE MOLD FLASH.
- 3) LEAD COPLANARITY SHALL BE 0.10 MILLIMETER MAX.
- 4) DRAWING CONFORMS TO JEDEC MO-229, VARIATION VEED-5.
- 5) DRAWING IS NOT TO SCALE.

**NOTICE:** The information in this document is subject to change without notice. Users should warrant and guarantee that third party Intellectual Property rights are not infringed upon when integrating MPS products into any application. MPS will not assume any legal responsibility for any said applications.

Компания «Life Electronics» занимается поставками электронных компонентов импортного и отечественного производства от производителей и со складов крупных дистрибьюторов Европы, Америки и Азии.

С конца 2013 года компания активно расширяет линейку поставок компонентов по направлению коаксиальный кабель, кварцевые генераторы и конденсаторы (керамические, пленочные, электролитические), за счёт заключения дистрибьюторских договоров

Мы предлагаем:

- Конкурентоспособные цены и скидки постоянным клиентам.
- Специальные условия для постоянных клиентов.
- Подбор аналогов.
- Поставку компонентов в любых объемах, удовлетворяющих вашим потребностям.
- Приемлемые сроки поставки, возможна ускоренная поставка.
- Доставку товара в любую точку России и стран СНГ.
- Комплексную поставку.
- Работу по проектам и поставку образцов.
- Формирование склада под заказчика.
- Сертификаты соответствия на поставляемую продукцию (по желанию клиента).
- Тестирование поставляемой продукции.
- Поставку компонентов, требующих военную и космическую приемку.
- Входной контроль качества.
- Наличие сертификата ISO.

В составе нашей компании организован Конструкторский отдел, призванный помогать разработчикам, и инженерам.

Конструкторский отдел помогает осуществить:

- Регистрацию проекта у производителя компонентов.
- Техническую поддержку проекта.
- Защиту от снятия компонента с производства.
- Оценку стоимости проекта по компонентам.
- Изготовление тестовой платы монтаж и пусконаладочные работы.



Тел: +7 (812) 336 43 04 (многоканальный)  
Email: [org@lifeelectronics.ru](mailto:org@lifeelectronics.ru)