



# R&E International

A Subsidiary of Microchip Technology Inc.

## RE46C112

### Ionization Smoke Detector IC

#### Product Specification

#### General Description

The RE46C112 is an ionization type smoke detector IC. It is intended for applications using ionization type chambers to detect smoke. When enabled, VOUT is  $\frac{1}{4}$  of either the DETECT input or VDD depending on the status of the SELECT input. When the Select input is allowed to float the circuit is in the low current mode with only the guard amplifier enabled.

Utilizing low power CMOS technology the RE46C112 was designed for use in smoke detectors that comply with Underwriters Laboratory Specification UL217.

#### Features

- Guard Outputs for Ion Detector Input
- $\pm 0.75\mu\text{A}$  Detect Input Current
- Microprocessor A/D Compatible Analog Output
- Low Quiescent Current Consumption ( $<10\mu\text{A}$ )
- Available in 8L PDIP or 8L N SOIC
- 2000V ESD Protection (HBM)
- Available in Standard Packaging or RoHS Compliant Pb Free Packaging

#### Pin Configuration

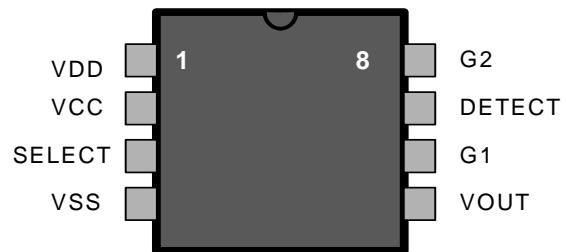

#### ABSOLUTE MAXIMUM RATINGS

PARAMETER	SYMBOL	VALUE	UNITS
Supply Voltage	$V_{DD}$	12.5	V
Supply Voltage	$V_{CC}$	6	V
Detect Input Voltage Range	$V_{INDET}$	$V_{DD} + .3$	V
SELECT Input Voltage Range	$V_{INSEL}$	$V_{CC} + .3$	V
Operating Temperature	$T_A$	-10 to 60	$^{\circ}\text{C}$
Storage Temperature	$T_{STG}$	-55 to 125	$^{\circ}\text{C}$
Maximum Junction Temperature	$T_J$	150	$^{\circ}\text{C}$

Stresses beyond those listed under Absolute Maximum Ratings may cause permanent damage to the device. These are stress ratings only and operation at these conditions for extended periods may affect device reliability.

This product utilizes CMOS technology with static protection; however proper ESD prevention procedures should be used when handling this product. Damage can occur when exposed to extremely high static electrical charge

# RE46C112

Ionization Smoke Detector IC  
Product Specification



R&E International  
A Subsidiary of Microchip Technology Inc.

## Electrical Characteristics at TA = 25°C, VDD=9V, VCC=5V, VSS=0V (unless otherwise noted)

Parameter	Symbol	Test Pin	Test Conditions	Limits			
				Min	Typ	Max	Units
Supply Voltage	V <sub>DD</sub>	1	Operating	6		12	V
	V <sub>CC</sub>	2	Operating	2.7		5.5	V
Supply Current	I <sub>DD</sub>	1	SELECT=open, DETECT=4.5V, VDD=9V		3	4.5	uA
		1	SELECT=open, DETECT=6V, VDD=12V		4	5.5	uA
		1	SELECT=VCC or VSS, DETECT=4.5V, VDD=9V		60	90	uA
	I <sub>CC</sub>	2	SELECT=open, VCC=5V, DETECT=4.5V, VDD=9V		2.75	4.3	uA
		2	SELECT=open, VCC=3V, DETECT=6V, VDD=12V		1	1.75	uA
Input Voltage High	V <sub>ih</sub>	3	SELECT	V <sub>CC</sub> -4			V
Input Voltage Low	V <sub>il</sub>	3	SELECT			0.4	V
Input Leakage	I <sub>Ldet</sub>	7	VDD=12V, DETECT=VDD or VSS, 0-40% RH	-0.75		0.75	pA
			VDD=12V, DETECT=VDD or VSS, 85% RH, See Note 1	-1.5		1.5	pA
	I <sub>Lsel</sub>	3	SELECT=VCC or VSS VCC=5V	-15		45	uA
			SELECT=VCC or VSS VCC=3V	-4		15	uA
Offset Voltage	V <sub>GOs</sub>	6,8		-50		50	mV
Common Mode Voltage	V <sub>CM</sub>	7	Guard Amplifier	2		V <sub>DD</sub> -5	V
Output Impedance		6,8	Guard Amplifier			10	kΩ
Output Voltage	V <sub>out</sub>	5	VDD=6V to 12V, SELECT=VSS, RL=10K	-2% - 20mV	.25*V <sub>DD</sub>	2% + 20mV	V
		5	DETECT= 2V to VDD-.5V, SELECT=VCC, RL=10K	-2% - 20mV	.25*V <sub>DETECT</sub>	2% + 20mV	V

Note 1: Sample test only



---

## PIN DESCRIPTIONS

**PIN 1 (VDD)** - This pin should be connected to the most positive supply potential, typically a 9 Volt battery. The VDD voltage can range between 6V and 12V with respect to VSS. Reverse battery protection must be provided externally.

**PIN 2 (VCC)** – This positive supply potential can range between 2.7V and 5.5V with respect to VSS and must be less than the VDD voltage. This pin is usually connected to a microprocessor positive supply voltage.

**PIN 3 (SELECT)** – This input pin determines the function of VOUT. This pin is typically driven by a microprocessor port. The input high level should not exceed VCC. If left floating VOUT is inactive and pulled internally to VSS. If SELECT is at the VIL (low) level then VOUT is nominally  $\frac{1}{4}$  of the VDD voltage. If SELECT is at the VIH level (high) then VOUT is nominally  $\frac{1}{4}$  of the DETECT voltage.

**PIN 4 (VSS)** – This pin is the negative supply potential and is usually connected to ground.

**PIN 5 (VOUT)** – This analog output is a representation of VDD or DETECT or is at VSS depending on the status of the SELECT input. Typically this output is connected to a microprocessor A to D input to monitor the status of the supply voltage and the ionization chamber voltage.

**PIN 6, 8 (G1, G2)** – These pins are connected to the internal guard amplifier output and are within  $\pm 50\text{mV}$  of the DETECT input. These outputs are always active and help to minimize surface leakage to the DETECT pin.

**PIN 7 (DETECT)** - This input is typically interfaced to an ionization chamber to sense the presence of smoke. Input leakage is less than  $\pm 75\text{pA}$  on this input.

# RE46C112

**Ionization Smoke Detector IC**  
Product Specification



**R&E International**  
A Subsidiary of Microchip Technology Inc.

Functional Block Diagram

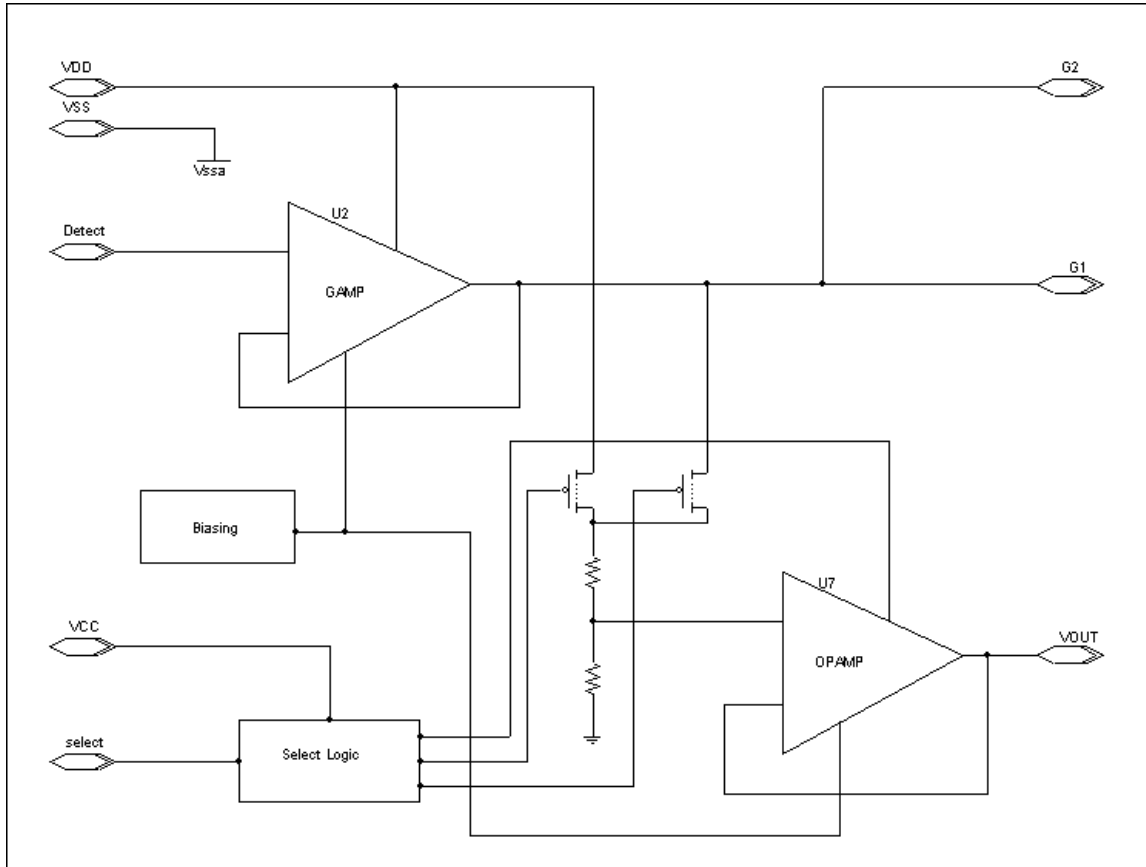

Figure 1

# RE46C112

**Ionization Smoke Detector IC**  
Product Specification



**R&E International**  
A Subsidiary of Microchip Technology Inc.

## Typical Application

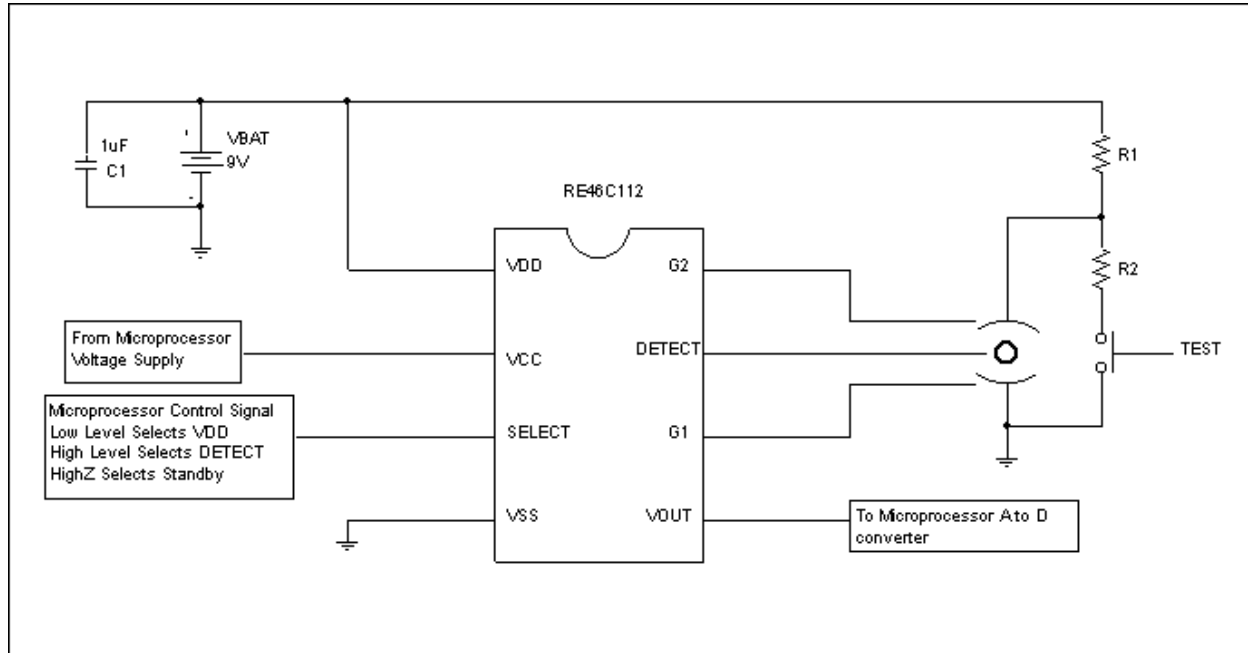

Figure 2

# RE46C112

## Ionization Smoke Detector IC Product Specification



**R&E International**  
A Subsidiary of Microchip Technology Inc.

Information contained in this publication regarding device applications and the like is provided only for your convenience and may be superseded by updates. It is your responsibility to ensure that your application meets with your specifications. MICROCHIP MAKES NO REPRESENTATIONS OR WARRANTIES OF ANY KIND WHETHER EXPRESS OR IMPLIED, WRITTEN OR ORAL, STATUTORY OR OTHERWISE, RELATED TO THE INFORMATION, INCLUDING BUT NOT LIMITED TO ITS CONDITION, QUALITY, PERFORMANCE, MERCHANTABILITY OR FITNESS FOR PURPOSE. Microchip disclaims all liability arising from this information and its use. Use of Microchip devices in life support and/or safety applications is entirely at the buyer's risk, and the buyer agrees to defend, indemnify and hold harmless Microchip from any and all damages, claims, suits, or expenses resulting from such use. No licenses are conveyed, implicitly or otherwise, under any Microchip intellectual property rights.

### Trademarks

The Microchip name and logo, the Microchip logo, Accuron, dsPIC, KEELOQ, KEELOQ logo, MPLAB, PIC, PICmicro, PICSTART, rfPIC, SmartShunt and UNI/O are registered trademarks of Microchip Technology Incorporated in the U.S.A. and other countries.

FilterLab, Hampshire, Linear Active Thermistor, MXDEV, MXLAB, SEEVAL, SmartSensor and The Embedded Control Solutions Company are registered trademarks of Microchip Technology Incorporated in the U.S.A.

Analog-for-the-Digital Age, Application Maestro, CodeGuard, dsPICDEM, dsPICDEM.net, dsPICworks, dsSPEAK, ECAN, ECONOMONITOR, FanSense, In-Circuit Serial Programming, ICSP, ICEPIC, Mindi, MiWi, MPASM, MPLAB Certified logo, MPLIB, MPLINK, mTouch, nanoWatt XLP, PICkit, PICDEM, PICDEM.net, PICtail, PIC<sup>32</sup> logo, PowerCal, PowerInfo, PowerMate, PowerTool, REAL ICE, rLAB, Select Mode, Total Endurance, TSHARC, WiperLock and ZENA are trademarks of Microchip Technology Incorporated in the U.S.A. and other countries.

SQTP is a service mark of Microchip Technology Incorporated in the U.S.A.

All other trademarks mentioned herein are property of their respective companies.

© 2009, Microchip Technology Incorporated, Printed in the U.S.A., All Rights Reserved.

 Printed on recycled paper.

**QUALITY MANAGEMENT SYSTEM**  
**CERTIFIED BY DNV**  
**== ISO/TS 16949:2002 ==**

*Microchip received ISO/TS-16949:2002 certification for its worldwide headquarters, design and wafer fabrication facilities in Chandler and Tempe, Arizona; Gresham, Oregon and design centers in California and India. The Company's quality system processes and procedures are for its PIC<sup>®</sup> MCUs and dsPIC<sup>®</sup> DSCs, KEELOQ<sup>®</sup> code hopping devices, Serial EEPROMs, microperipherals, nonvolatile memory and analog products. In addition, Microchip's quality system for the design and manufacture of development systems is ISO 9001:2000 certified.*

# **RE46C112**

***Ionization Smoke Detector IC***  
*Product Specification*



***R&E International***  
*A Subsidiary of Microchip Technology Inc.*

---

Компания «Life Electronics» занимается поставками электронных компонентов импортного и отечественного производства от производителей и со складов крупных дистрибьюторов Европы, Америки и Азии.

С конца 2013 года компания активно расширяет линейку поставок компонентов по направлению коаксиальный кабель, кварцевые генераторы и конденсаторы (керамические, пленочные, электролитические), за счёт заключения дистрибьюторских договоров

Мы предлагаем:

- Конкуренспособные цены и скидки постоянным клиентам.
- Специальные условия для постоянных клиентов.
- Подбор аналогов.
- Поставку компонентов в любых объемах, удовлетворяющих вашим потребностям.
- Приемлемые сроки поставки, возможна ускоренная поставка.
- Доставку товара в любую точку России и стран СНГ.
- Комплексную поставку.
- Работу по проектам и поставку образцов.
- Формирование склада под заказчика.
- Сертификаты соответствия на поставляемую продукцию (по желанию клиента).
- Тестирование поставляемой продукции.
- Поставку компонентов, требующих военную и космическую приемку.
- Входной контроль качества.
- Наличие сертификата ISO.

В составе нашей компании организован Конструкторский отдел, призванный помогать разработчикам, и инженерам.

Конструкторский отдел помогает осуществить:

- Регистрацию проекта у производителя компонентов.
- Техническую поддержку проекта.
- Защиту от снятия компонента с производства.
- Оценку стоимости проекта по компонентам.
- Изготовление тестовой платы монтаж и пусконаладочные работы.



Тел: +7 (812) 336 43 04 (многоканальный)

Email: [org@lifeelectronics.ru](mailto:org@lifeelectronics.ru)