

# 74HC4060-Q100; 74HCT4060-Q100

14-stage binary ripple counter with oscillator

Rev. 3 — 8 May 2020

Product data sheet

## 1. General description

---

The 74HC4060-Q100; 74HCT4060-Q100 is a 14-stage ripple-carry counter/divider and oscillator with three oscillator terminals (RS, RTC and CTC), ten buffered parallel outputs (Q3 to Q9 and Q11 to Q13) and an overriding asynchronous master reset (MR). The oscillator configuration allows design of either RC or crystal oscillator circuits. The oscillator may be replaced by an external clock signal at input RS. In this case, keep the oscillator pins (RTC and CTC) floating. The counter advances on the HIGH-to-LOW transition of RS. A HIGH level on MR clears all counter stages and forces all outputs LOW, independent of the other input conditions. Inputs include clamp diodes. This enables the use of current limiting resistors to interface inputs to voltages in excess of  $V_{CC}$ .

This product has been qualified to the Automotive Electronics Council (AEC) standard Q100 (Grade 1) and is suitable for use in automotive applications.

## 2. Features and benefits

---

- Automotive product qualification in accordance with AEC-Q100 (Grade 1)
  - Specified from -40 °C to +85 °C and from -40 °C to +125 °C
- All active components on chip
- RC or crystal oscillator configuration
- Complies with JEDEC standard no. 7 A
- Input levels:
  - For 74HC4060-Q100: CMOS level
  - For 74HCT4060-Q100: TTL level
- ESD protection:
  - MIL-STD-883, method 3015 exceeds 2000 V
  - HBM JESD22-A114F exceeds 2000 V
  - MM JESD22-A115-A exceeds 200 V (C = 200 pF, R = 0 Ω)
- Multiple package options
- DHVQFN package with Side-Wettable Flanks enabling Automatic Optical Inspection (AOI) of solder joints

## 3. Applications

---

- Control counters
- Timers
- Frequency dividers
- Time-delay circuits

### 4. Ordering information

Table 1. Ordering information

Type number	Package			Version
	Temperature range	Name	Description	
74HC4060D-Q100	-40 °C to +125 °C	SO16	plastic small outline package; 16 leads; body width 3.9 mm	SOT109-1
74HCT4060D-Q100				
74HC4060DB-Q100	-40 °C to +125 °C	SSOP16	plastic shrink small outline package; 16 leads; body width 5.3 mm	SOT338-1
74HC4060PW-Q100	-40 °C to +125 °C	TSSOP16	plastic thin shrink small outline package; 16 leads; body width 4.4 mm	SOT403-1
74HC4060BQ-Q100	-40 °C to +125 °C	DHVQFN16	plastic dual in-line compatible thermal enhanced very thin quad flat package; no leads; 16 terminals; body 2.5 × 3.5 × 0.85 mm	SOT763-1
74HCT4060BQ-Q100				

### 5. Functional diagram



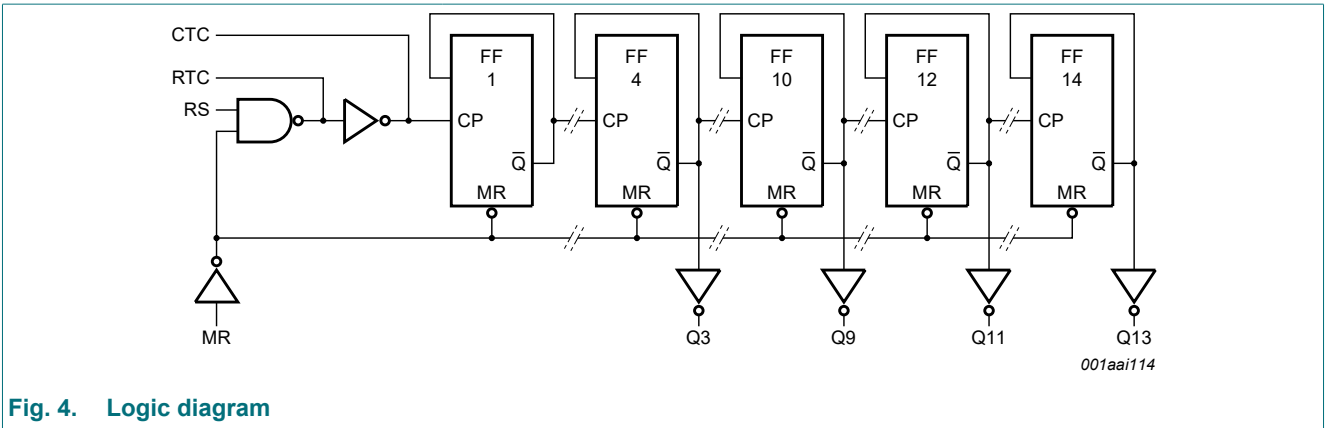


Fig. 4. Logic diagram

## 6. Pinning information

### 6.1. Pinning

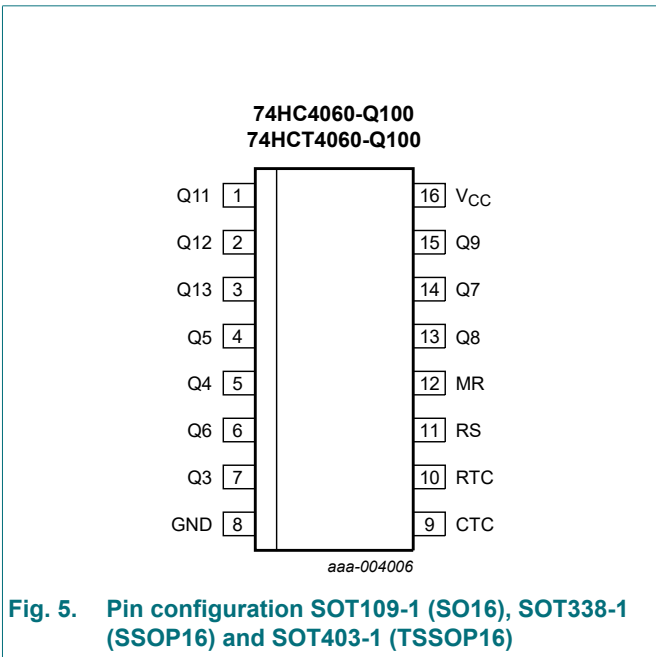


Fig. 5. Pin configuration SOT109-1 (SO16), SOT338-1 (SSOP16) and SOT403-1 (TSSOP16)

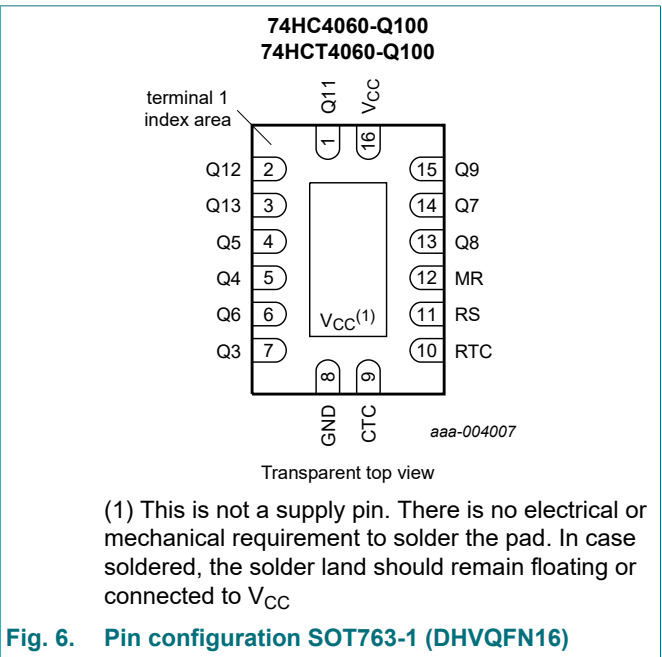


Fig. 6. Pin configuration SOT763-1 (DHVQFN16)

### 6.2. Pin description

Table 2. Pin description

Symbol	Pin	Description
Q11, Q12, Q13	1, 2, 3	counter output
Q3, Q4, Q5, Q6, Q7, Q8, Q9	7, 5, 4, 6, 14, 13, 15	counter output
GND	8	ground (0 V)
CTC	9	external capacitor connection
RTC	10	external resistor connection
RS	11	clock input /oscillator pin
MR	12	master reset input (active HIGH)
V <sub>CC</sub>	16	supply voltage

## 7. Functional description

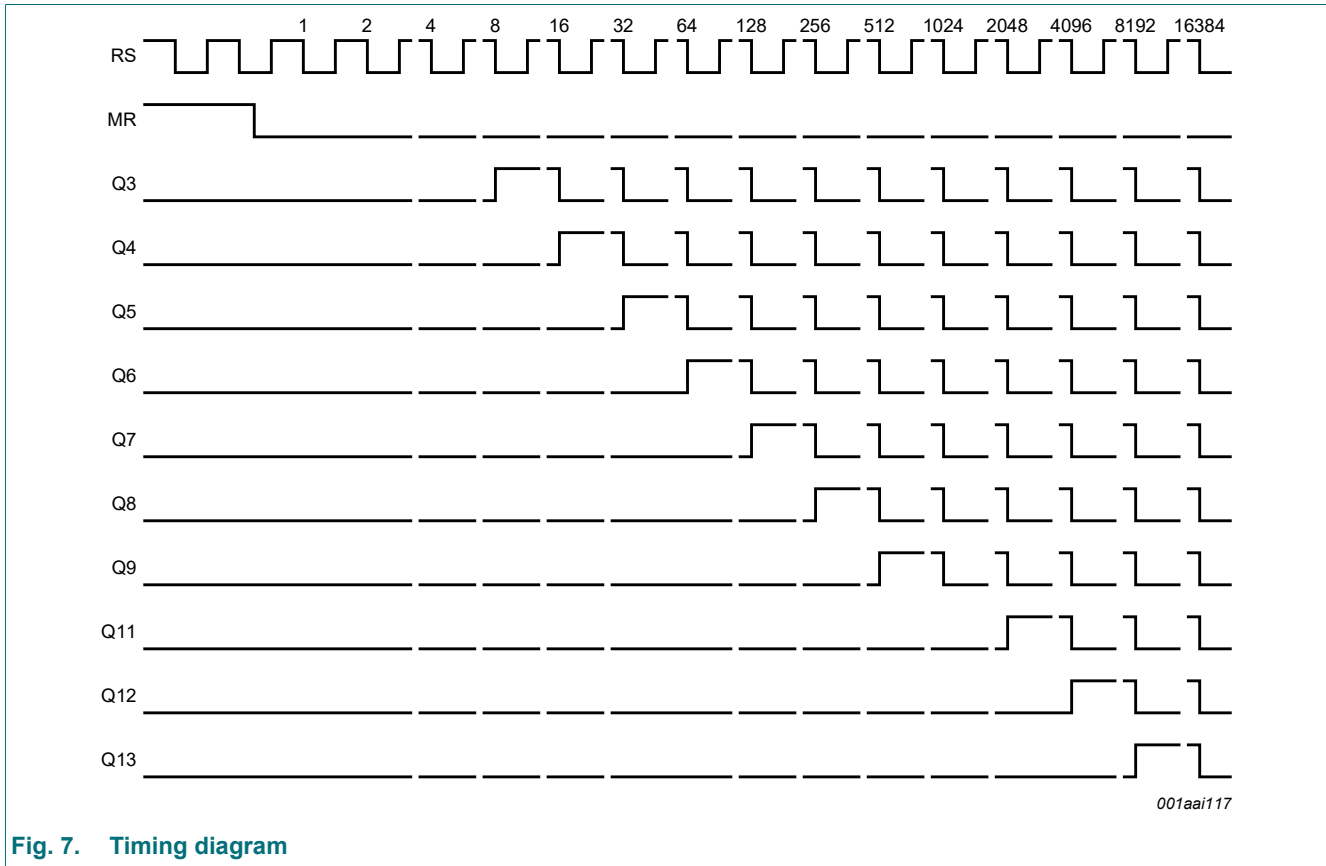


Fig. 7. Timing diagram

## 8. Limiting values

Table 3. Limiting values

In accordance with the Absolute Maximum Rating System (IEC 60134). Voltages are referenced to GND (ground = 0 V).

Symbol	Parameter	Conditions	Min	Max	Unit
$V_{CC}$	supply voltage		-0.5	+7	V
$I_{IK}$	input clamping current	$V_I < -0.5\text{ V}$ or $V_I > V_{CC} + 0.5\text{ V}$ [1]	-	$\pm 20$	mA
$I_{OK}$	output clamping current	$V_O < -0.5\text{ V}$ or $V_O > V_{CC} + 0.5\text{ V}$ [1]	-	$\pm 20$	mA
$I_O$	output current	$-0.5\text{ V} < V_O < V_{CC} + 0.5\text{ V}$	-	$\pm 25$	mA
$I_{CC}$	supply current		-	50	mA
$I_{GND}$	ground current		-50	-	mA
$T_{stg}$	storage temperature		-65	+150	°C
$P_{tot}$	total power dissipation	$T_{amb} = -40\text{ °C}$ to $+125\text{ °C}$ [2]	-	500	mW

[1] The input and output voltage ratings may be exceeded if the input and output current ratings are observed.

[2] For SOT109-1 (SO16) package:  $P_{tot}$  derates linearly with 12.4 mW/K above 110 °C.  
 For SOT338-1 (SSOP16) package:  $P_{tot}$  derates linearly with 8.5 mW/K above 91 °C.  
 For SOT403-1 (TSSOP16) package:  $P_{tot}$  derates linearly with 8.5 mW/K above 91 °C.  
 For SOT763-1 (DHVQFN16) package:  $P_{tot}$  derates linearly with 11.2 mW/K above 106 °C.

## 9. Recommended operating conditions

**Table 4. Recommended operating conditions**

Voltages are referenced to GND (ground = 0 V)

Symbol	Parameter	Conditions	74HC4060-Q100			74HCT4060-Q100			Unit
			Min	Typ	Max	Min	Typ	Max	
V <sub>CC</sub>	supply voltage		2.0	5.0	6.0	4.5	5.0	5.5	V
V <sub>I</sub>	input voltage		0	-	V <sub>CC</sub>	0	-	V <sub>CC</sub>	V
V <sub>O</sub>	output voltage		0	-	V <sub>CC</sub>	0	-	V <sub>CC</sub>	V
T <sub>amb</sub>	ambient temperature		-40	-	+125	-40	-	+125	°C
Δt/ΔV	input transition rise and fall rate	V <sub>CC</sub> = 2.0 V	-	-	625	-	-	-	ns/V
		V <sub>CC</sub> = 4.5 V	-	1.67	139	-	1.67	139	ns/V
		V <sub>CC</sub> = 6.0 V	-	-	83	-	-	-	ns/V

## 10. Static characteristics

**Table 5. Static characteristics**

At recommended operating conditions; voltages are referenced to GND (ground = 0 V).

Symbol	Parameter	Conditions	25 °C			-40 °C to +85 °C		-40 °C to +125 °C		Unit
			Min	Typ	Max	Min	Max	Min	Max	
<b>74HC4060-Q100</b>										
V <sub>IH</sub>	HIGH-level input voltage	MR input								
		V <sub>CC</sub> = 2.0 V	1.5	1.3	-	1.5	-	1.5	-	V
		V <sub>CC</sub> = 4.5 V	3.15	2.4	-	3.15	-	3.15	-	V
		V <sub>CC</sub> = 6.0 V	4.2	3.1	-	4.2	-	4.2	-	V
		RS input								
		V <sub>CC</sub> = 2.0 V	1.7	-	-	1.7	-	1.7	-	V
		V <sub>CC</sub> = 4.5 V	3.6	-	-	3.6	-	3.6	-	V
V <sub>CC</sub> = 6.0 V	4.8	-	-	4.8	-	4.8	-	V		
V <sub>IL</sub>	LOW-level input voltage	MR input								
		V <sub>CC</sub> = 2.0 V	-	0.8	0.5	-	0.5	-	0.5	V
		V <sub>CC</sub> = 4.5 V	-	2.1	1.35	-	1.35	-	1.35	V
		V <sub>CC</sub> = 6.0 V	-	2.8	1.8	-	1.8	-	1.8	V
		RS input								
		V <sub>CC</sub> = 2.0 V	-	-	0.3	-	0.3	-	0.3	V
		V <sub>CC</sub> = 4.5 V	-	-	0.9	-	0.9	-	0.9	V
V <sub>CC</sub> = 6.0 V	-	-	1.2	-	1.2	-	1.2	V		

Symbol	Parameter	Conditions	25 °C			-40 °C to +85 °C		-40 °C to +125 °C		Unit
			Min	Typ	Max	Min	Max	Min	Max	
V <sub>OH</sub>	HIGH-level output voltage	RTC output; RS = MR = GND								
		I <sub>O</sub> = -20 μA; V <sub>CC</sub> = 2.0 V	1.9	2.0	-	1.9	-	1.9	-	V
		I <sub>O</sub> = -20 μA; V <sub>CC</sub> = 4.5 V	4.4	4.5	-	4.4	-	4.4	-	V
		I <sub>O</sub> = -20 μA; V <sub>CC</sub> = 6.0 V	5.9	6.0	-	5.9	-	5.9	-	V
		I <sub>O</sub> = -2.6 mA; V <sub>CC</sub> = 4.5 V	3.98	-	-	3.84	-	3.7	-	V
		I <sub>O</sub> = -3.3 mA; V <sub>CC</sub> = 6.0 V	5.48	-	-	5.34	-	5.2	-	V
		RTC output; RS = MR = V <sub>CC</sub>								
		I <sub>O</sub> = -20 μA; V <sub>CC</sub> = 2.0 V	1.9	2.0	-	1.9	-	1.9	-	V
		I <sub>O</sub> = -20 μA; V <sub>CC</sub> = 4.5 V	4.4	4.5	-	4.4	-	4.4	-	V
		I <sub>O</sub> = -20 μA; V <sub>CC</sub> = 6.0 V	5.9	6.0	-	5.9	-	5.9	-	V
		I <sub>O</sub> = -0.65 mA; V <sub>CC</sub> = 4.5 V	3.98	-	-	3.84	-	3.7	-	V
		I <sub>O</sub> = -0.85 mA; V <sub>CC</sub> = 6.0 V	5.48	-	-	5.34	-	5.2	-	V
		CTC output; RS = V <sub>IH</sub> ; MR = V <sub>IL</sub>								
		I <sub>O</sub> = -3.2 mA; V <sub>CC</sub> = 4.5 V	3.98	-	-	3.84	-	3.7	-	V
		I <sub>O</sub> = -4.2 mA; V <sub>CC</sub> = 6.0 V	5.48	-	-	5.34	-	5.2	-	V
		V <sub>I</sub> = V <sub>IH</sub> or V <sub>IL</sub> ; except RTC output								
		I <sub>O</sub> = -20 μA; V <sub>CC</sub> = 2.0 V	1.9	2.0	-	1.9	-	1.9	-	V
		I <sub>O</sub> = -20 μA; V <sub>CC</sub> = 4.5 V	4.4	4.5	-	4.4	-	4.4	-	V
		I <sub>O</sub> = -20 μA; V <sub>CC</sub> = 6.0 V	5.9	6.0	-	5.9	-	5.9	-	V
		V <sub>I</sub> = V <sub>IH</sub> or V <sub>IL</sub> ; except RTC and CTC outputs								
I <sub>O</sub> = -4.0 mA; V <sub>CC</sub> = 4.5 V	3.98	-	-	3.84	-	3.7	-	V		
I <sub>O</sub> = -5.2 mA; V <sub>CC</sub> = 6.0 V	5.48	-	-	5.34	-	5.2	-	V		
V <sub>OL</sub>	LOW-level output voltage	RTC output; RS = V <sub>CC</sub> ; MR = GND								
		I <sub>O</sub> = 20 μA; V <sub>CC</sub> = 2.0 V	-	0	0.1	-	0.1	-	0.1	V
		I <sub>O</sub> = 20 μA; V <sub>CC</sub> = 4.5 V	-	0	0.1	-	0.1	-	0.1	V
		I <sub>O</sub> = 20 μA; V <sub>CC</sub> = 6.0 V	-	0	0.1	-	0.1	-	0.1	V
		I <sub>O</sub> = 2.6 mA; V <sub>CC</sub> = 4.5 V	-	-	0.26	-	0.33	-	0.4	V
		I <sub>O</sub> = 3.3 mA; V <sub>CC</sub> = 6.0 V	-	-	0.26	-	0.33	-	0.4	V
		CTC output; RS = V <sub>IL</sub> ; MR = V <sub>IH</sub>								
		I <sub>O</sub> = 3.2 mA; V <sub>CC</sub> = 4.5 V	-	-	0.26	-	0.33	-	0.4	V
		I <sub>O</sub> = 4.2 mA; V <sub>CC</sub> = 6.0 V	-	-	0.26	-	0.33	-	0.4	V
		V <sub>I</sub> = V <sub>IH</sub> or V <sub>IL</sub> ; except RTC output								
		I <sub>O</sub> = 20 μA; V <sub>CC</sub> = 2.0 V	-	0	0.1	-	0.1	-	0.1	V
		I <sub>O</sub> = 20 μA; V <sub>CC</sub> = 4.5 V	-	0	0.1	-	0.1	-	0.1	V
		I <sub>O</sub> = 20 μA; V <sub>CC</sub> = 6.0 V	-	0	0.1	-	0.1	-	0.1	V
		V <sub>I</sub> = V <sub>IH</sub> or V <sub>IL</sub> ; except RTC and CTC outputs								
		I <sub>O</sub> = 4.0 mA; V <sub>CC</sub> = 4.5 V	-	-	0.26	-	0.33	-	0.4	V
		I <sub>O</sub> = 5.2 mA; V <sub>CC</sub> = 6.0 V	-	-	0.26	-	0.33	-	0.4	V

Symbol	Parameter	Conditions	25 °C			-40 °C to +85 °C		-40 °C to +125 °C		Unit
			Min	Typ	Max	Min	Max	Min	Max	
$I_I$	input leakage current	$V_I = V_{CC}$ or GND; $V_{CC} = 6.0$ V	-	-	±0.1	-	±1.0	-	±1.0	µA
$I_{CC}$	supply current	$V_I = V_{CC}$ or GND; $I_O = 0$ A; $V_{CC} = 6.0$ V	-	-	8.0	-	80	-	160	µA
$C_I$	input capacitance		-	3.5	-	-	-	-	-	pF
<b>74HCT4060-Q100</b>										
$V_{IH}$	HIGH-level input voltage	MR input; $V_{CC} = 4.5$ V to 5.5 V [1]	2.0	-	-	2.0	-	2.0	-	V
		RS input; $V_{CC} = 4.5$ V	3.6	-	-	3.6	-	3.6	-	V
$V_{IL}$	LOW-level input voltage	MR input; $V_{CC} = 4.5$ V to 5.5 V [1]	-	-	0.8	-	0.8	-	0.8	V
		RS input; $V_{CC} = 4.5$ V	-	-	0.9	-	0.9	-	0.9	V
$V_{OH}$	HIGH-level output voltage	RTC output; RS = MR = $V_{CC}$								
		$I_O = -20$ µA; $V_{CC} = 4.5$ V	4.4	4.5	-	4.4	-	4.4	-	V
		$I_O = -0.65$ mA; $V_{CC} = 4.5$ V	3.98	-	-	3.84	-	3.7	-	V
		RTC output; RS = MR = GND								
		$I_O = -20$ µA; $V_{CC} = 4.5$ V	4.4	4.5	-	4.4	-	4.4	-	V
		$I_O = -2.6$ mA; $V_{CC} = 4.5$ V	3.98	-	-	3.84	-	3.7	-	V
		CTC output; RS = $V_{IH}$ ; MR = $V_{IL}$								
		$I_O = -3.2$ mA; $V_{CC} = 4.5$ V	3.98	-	-	3.84	-	3.7	-	V
		$V_I = V_{IH}$ or $V_{IL}$ ; except RTC output								
		$I_O = -20$ µA; $V_{CC} = 4.5$ V	4.4	4.5	-	4.4	-	4.4	-	V
$V_{OL}$	LOW-level output voltage	$V_I = V_{IH}$ or $V_{IL}$ ; except RTC and CTC outputs								
		$I_O = -4.0$ mA; $V_{CC} = 4.5$ V	3.98	-	-	3.84	-	3.7	-	V
		RTC output; RS = $V_{CC}$ ; MR = GND								
		$I_O = 20$ µA; $V_{CC} = 4.5$ V	-	0	0.1	-	0.1	-	0.1	V
		$I_O = 2.6$ mA; $V_{CC} = 4.5$ V	-	-	0.26	-	0.33	-	0.4	V
		CTC output; RS = $V_{IL}$ ; MR = $V_{IH}$								
		$I_O = 3.2$ mA; $V_{CC} = 4.5$ V	-	-	0.26	-	0.33	-	0.4	V
		$V_I = V_{IH}$ or $V_{IL}$ ; except RTC output								
$I_O = 20$ µA; $V_{CC} = 4.5$ V	-	0	0.1	-	0.1	-	0.1	V		
$I_I$	input leakage current	$V_I = V_{CC}$ or GND; $V_{CC} = 5.5$ V	-	-	±0.1	-	±1.0	-	±1.0	µA
		$V_I = V_{CC}$ or GND; $V_{CC} = 5.5$ V; $I_O = 0$ A	-	-	8.0	-	80	-	160	µA
$\Delta I_{CC}$	additional supply current	per input pin; $V_I = V_{CC} - 2.1$ V; other inputs at $V_{CC}$ or GND; $V_{CC} = 4.5$ V to 5.5 V; $I_O = 0$ A	-	40	144	-	180	-	196	µA
$C_I$	input capacitance		-	3.5	-	-	-	-	-	pF

[1] For HCT4060, only input MR (pin 12) has TTL input switching levels.

## 11. Dynamic characteristics

**Table 6. Dynamic characteristics**

$GND = 0\text{ V}$ ;  $C_L = 50\text{ pF}$  unless otherwise specified; for test circuit see [Fig. 11](#).

Symbol	Parameter	Conditions	25 °C			-40 °C to +85 °C		-40 °C to +125 °C		Unit
			Min	Typ	Max	Min	Max	Min	Max	
<b>74HC4060-Q100</b>										
$t_{pd}$	propagation delay	RS to Q3; see <a href="#">Fig. 8</a> [1]								
		$V_{CC} = 2.0\text{ V}$	-	99	300	-	375	-	450	ns
		$V_{CC} = 4.5\text{ V}$	-	36	60	-	75	-	90	ns
		$V_{CC} = 5.0\text{ V}$ ; $C_L = 15\text{ pF}$	-	31	-	-	-	-	-	ns
		$V_{CC} = 6.0\text{ V}$	-	29	51	-	64	-	77	ns
		Qn to Qn+1; see <a href="#">Fig. 9</a> [2]								
		$V_{CC} = 2.0\text{ V}$	-	22	80	-	100	-	120	ns
		$V_{CC} = 4.5\text{ V}$	-	8	16	-	20	-	24	ns
		$V_{CC} = 5.0\text{ V}$ ; $C_L = 15\text{ pF}$	-	6	-	-	-	-	-	ns
$V_{CC} = 6.0\text{ V}$	-	6	14	-	17	-	20	ns		
$t_{PHL}$	HIGH to LOW propagation delay	MR to Qn; see <a href="#">Fig. 10</a>								
		$V_{CC} = 2.0\text{ V}$	-	55	175	-	220	-	265	ns
		$V_{CC} = 4.5\text{ V}$	-	20	35	-	44	-	53	ns
		$V_{CC} = 5.0\text{ V}$ ; $C_L = 15\text{ pF}$	-	17	-	-	-	-	-	ns
		$V_{CC} = 6.0\text{ V}$	-	16	30	-	37	-	45	ns
$t_t$	transition time	Qn; see <a href="#">Fig. 8</a> [3]								
		$V_{CC} = 2.0\text{ V}$	-	19	75	-	95	-	110	ns
		$V_{CC} = 4.5\text{ V}$	-	7	15	-	19	-	22	ns
		$V_{CC} = 6.0\text{ V}$	-	6	13	-	16	-	19	ns
$t_w$	pulse width	RS (HIGH or LOW); see <a href="#">Fig. 8</a>								
		$V_{CC} = 2.0\text{ V}$	80	17	-	100	-	120	-	ns
		$V_{CC} = 4.5\text{ V}$	16	6	-	20	-	24	-	ns
		$V_{CC} = 6.0\text{ V}$	14	5	-	17	-	20	-	ns
		MR (HIGH); see <a href="#">Fig. 10</a>								
		$V_{CC} = 2.0\text{ V}$	80	25	-	100	-	120	-	ns
		$V_{CC} = 4.5\text{ V}$	16	9	-	20	-	24	-	ns
		$V_{CC} = 6.0\text{ V}$	14	7	-	17	-	20	-	ns
$t_{rec}$	recovery time	MR to RS; see <a href="#">Fig. 10</a>								
		$V_{CC} = 2.0\text{ V}$	100	28	-	125	-	150	-	ns
		$V_{CC} = 4.5\text{ V}$	20	10	-	25	-	30	-	ns
		$V_{CC} = 6.0\text{ V}$	17	8	-	21	-	26	-	ns



Symbol	Parameter	Conditions	25 °C			-40 °C to +85 °C		-40 °C to +125 °C		Unit
			Min	Typ	Max	Min	Max	Min	Max	
f <sub>max</sub>	maximum frequency	RS; see Fig. 8								
		V <sub>CC</sub> = 2.0 V	6	26	-	4.8	-	4	-	MHz
		V <sub>CC</sub> = 4.5 V	30	80	-	24	-	20	-	MHz
		V <sub>CC</sub> = 5.0 V; C <sub>L</sub> = 15 pF	-	87	-	-	-	-	-	MHz
		V <sub>CC</sub> = 6.0 V	35	95	-	28	-	24	-	MHz
C <sub>PD</sub>	power dissipation capacitance	V <sub>I</sub> = GND to V <sub>CC</sub> ; V <sub>CC</sub> = 5 V; f <sub>i</sub> = 1 MHz [4]	-	40	-	-	-	-	-	pF
<b>74HCT4060-Q100</b>										
t <sub>pd</sub>	propagation delay	RS to Q3; see Fig. 8 [1]								
		V <sub>CC</sub> = 4.5 V	-	33	66	-	83	-	99	ns
		V <sub>CC</sub> = 5.0 V; C <sub>L</sub> = 15 pF	-	31	-	-	-	-	-	ns
		Qn to Qn+1; see Fig. 9 [2]								
		V <sub>CC</sub> = 4.5 V	-	8	16	-	20	-	24	ns
		V <sub>CC</sub> = 5.0 V; C <sub>L</sub> = 15 pF	-	6	-	-	-	-	-	ns
t <sub>PHL</sub>	HIGH to LOW propagation delay	MR to Qn; see Fig. 10								
		V <sub>CC</sub> = 4.5 V	-	21	44	-	55	-	66	ns
		V <sub>CC</sub> = 5.0 V; C <sub>L</sub> = 15 pF	-	18	-	-	-	-	-	ns
t <sub>t</sub>	transition time	Qn; see Fig. 8 [3]								
		V <sub>CC</sub> = 4.5 V	-	7	15	-	19	-	22	ns
t <sub>w</sub>	pulse width	RS (HIGH or LOW); see Fig. 8								
		V <sub>CC</sub> = 4.5 V	16	6	-	20	-	24	-	ns
		MR (HIGH); see Fig. 10								
		V <sub>CC</sub> = 4.5 V	16	6	-	20	-	24	-	ns
t <sub>rec</sub>	recovery time	MR to RS; see Fig. 10								
		V <sub>CC</sub> = 4.5 V	26	13	-	33	-	39	-	ns
f <sub>max</sub>	maximum frequency	RS; see Fig. 8								
		V <sub>CC</sub> = 4.5 V	30	80	-	24	-	20	-	MHz
		V <sub>CC</sub> = 5.0 V; C <sub>L</sub> = 15 pF	-	88	-	-	-	-	-	MHz
C <sub>PD</sub>	power dissipation capacitance	V <sub>I</sub> = GND to V <sub>CC</sub> - 1.5 V; V <sub>CC</sub> = 5 V; f <sub>i</sub> = 1 MHz [4]	-	40	-	-	-	-	-	pF

[1] t<sub>pd</sub> is the same as t<sub>PHL</sub> and t<sub>PLH</sub>.

[2] Qn+1 is the next Qn output.

[3] t<sub>t</sub> is the same as t<sub>THL</sub> and t<sub>TLH</sub>.

[4] C<sub>PD</sub> is used to determine the dynamic power dissipation (P<sub>D</sub> in μW):

$$P_D = C_{PD} \times V_{CC}^2 \times f_i \times N + \sum(C_L \times V_{CC}^2 \times f_o) \text{ where:}$$

f<sub>i</sub> = input frequency in MHz;

f<sub>o</sub> = output frequency in MHz;

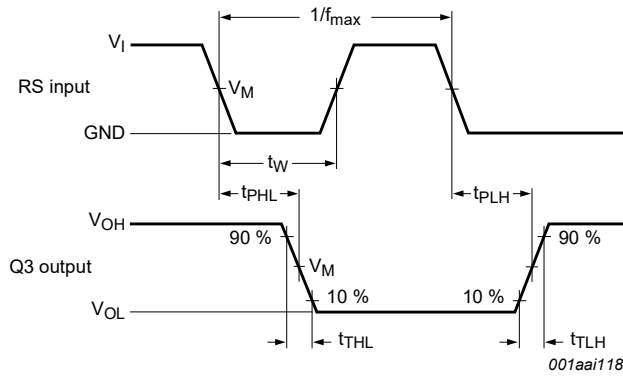
C<sub>L</sub> = output load capacitance in pF;

V<sub>CC</sub> = supply voltage in V;

N = number of inputs switching;

$\sum(C_L \times V_{CC}^2 \times f_o)$  = sum of outputs.

11.1. Waveforms and test circuit



Measurement points are given in [Table 7](#).

$V_{OL}$  and  $V_{OH}$  are typical voltage output levels that occur with the output load.

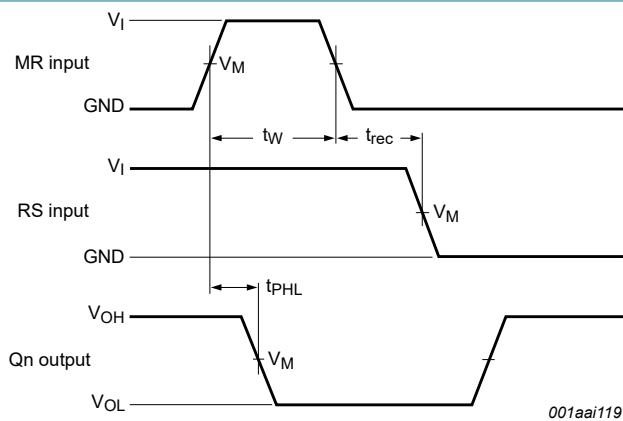
**Fig. 8. Waveforms showing the clock (RS) to output (Q3) propagation delays, the clock pulse width, the output transition times and the maximum clock frequency**



Measurement points are given in [Table 7](#).

$V_{OL}$  and  $V_{OH}$  are typical voltage output levels that occur with the output load.

**Fig. 9. Waveforms showing the output  $Q_n$  to output  $Q_{n+1}$  propagation delays**



Measurement points are given in [Table 7](#).

$V_{OL}$  and  $V_{OH}$  are typical voltage output levels that occur with the output load.

**Fig. 10. Waveforms showing the master reset (MR) pulse width, the master reset to output ( $Q_n$ ) propagation delays and the master reset to clock (RS) recovery time**

Table 7. Measurement points

Type	Input	Output
	$V_M$	$V_M$
74HC4060-Q100	$0.5 \times V_{CC}$	$0.5 \times V_{CC}$
74HCT4060-Q100	1.3 V	1.3 V



Fig. 11. Test circuit for measuring switching times

Table 8. Test data

Type	Input		Load
	$V_I$	$t_r, t_f$	$C_L$
74HC4060-Q100	$V_{CC}$	6 ns	15 pF, 50 pF
74HCT4060-Q100	3 V	6 ns	15 pF, 50 pF

## 12. RC oscillator

### 12.1. Timing component limitations

The oscillator frequency is mainly determined by  $R_t C_t$ , provided  $R_2 \approx 2R_t$  and  $R_2 C_2 \ll R_t C_t$ . The function of  $R_2$  is to minimize the influence of the forward voltage across the input protection diodes on the frequency. The stray capacitance  $C_2$  should be kept as small as possible. In consideration of accuracy,  $C_t$  must be larger than the inherent stray capacitance.  $R_t$  must be larger than the ON resistance in series with it, which typically is 280  $\Omega$  at  $V_{CC} = 2.0$  V, 130  $\Omega$  at  $V_{CC} = 4.5$  V and 100  $\Omega$  at  $V_{CC} = 6.0$  V.



Fig. 12. Example of a RC oscillator

The recommended values for these components to maintain agreement with the typical oscillation formula are:

- $C_t > 50$  pF, up to any practical value and  $10 \text{ k}\Omega < R_t < 1 \text{ M}\Omega$ .
- In order to avoid start-up problems,  $R_t \geq 1 \text{ k}\Omega$ .

### 12.2. Typical crystal oscillator circuit

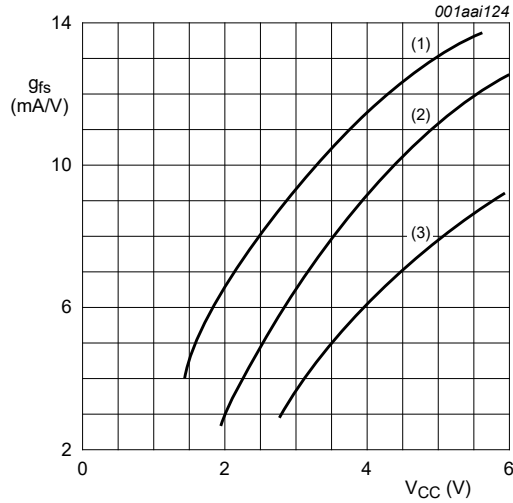
In Fig. 13, R2 is the power limiting resistor. For starting and maintaining oscillation a minimum transconductance is necessary, so R2 should not be too large. A practical value for R2 is 2.2 kΩ.



Fig. 13. External component connection for a crystal oscillator

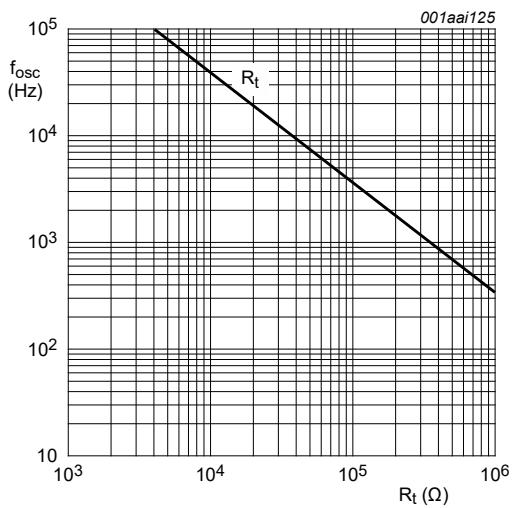


Fig. 14. Test set-up for measuring forward transconductance



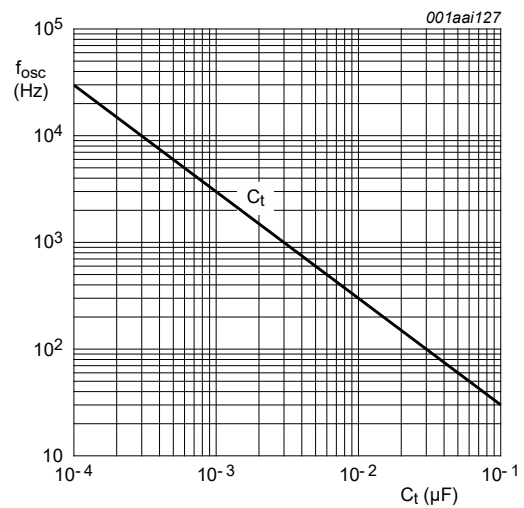
(1) Maximum.  
(2) Typical.  
(3) Minimum.  
 $T_{amb} = 25\text{ }^{\circ}\text{C}$ .

Fig. 15. Typical forward transconductance as function of the supply voltage



$V_{CC} = 2.0\text{ V to }6.0\text{ V}$ ;  $T_{amb} = 25\text{ }^{\circ}\text{C}$ .  
For  $R_t$  curve:  $C_t = 1\text{ nF}$ ;  $R_2 = 2 \times R_t$ .

Fig. 16. RC oscillator frequency as a function of  $R_t$



$V_{CC} = 2.0\text{ V to }6.0\text{ V}$ ;  $T_{amb} = 25\text{ }^{\circ}\text{C}$ .  
For  $C_t$  curve:  $R_t = 100\text{ k}\Omega$ ;  $R_2 = 200\text{ k}\Omega$ .

Fig. 17. RC oscillator frequency as a function of  $C_t$

### 13. Package outline

SO16: plastic small outline package; 16 leads; body width 3.9 mm

SOT109-1



Fig. 18. Package outline SOT109-1 (SO16)

SSOP16: plastic shrink small outline package; 16 leads; body width 5.3 mm

SOT338-1

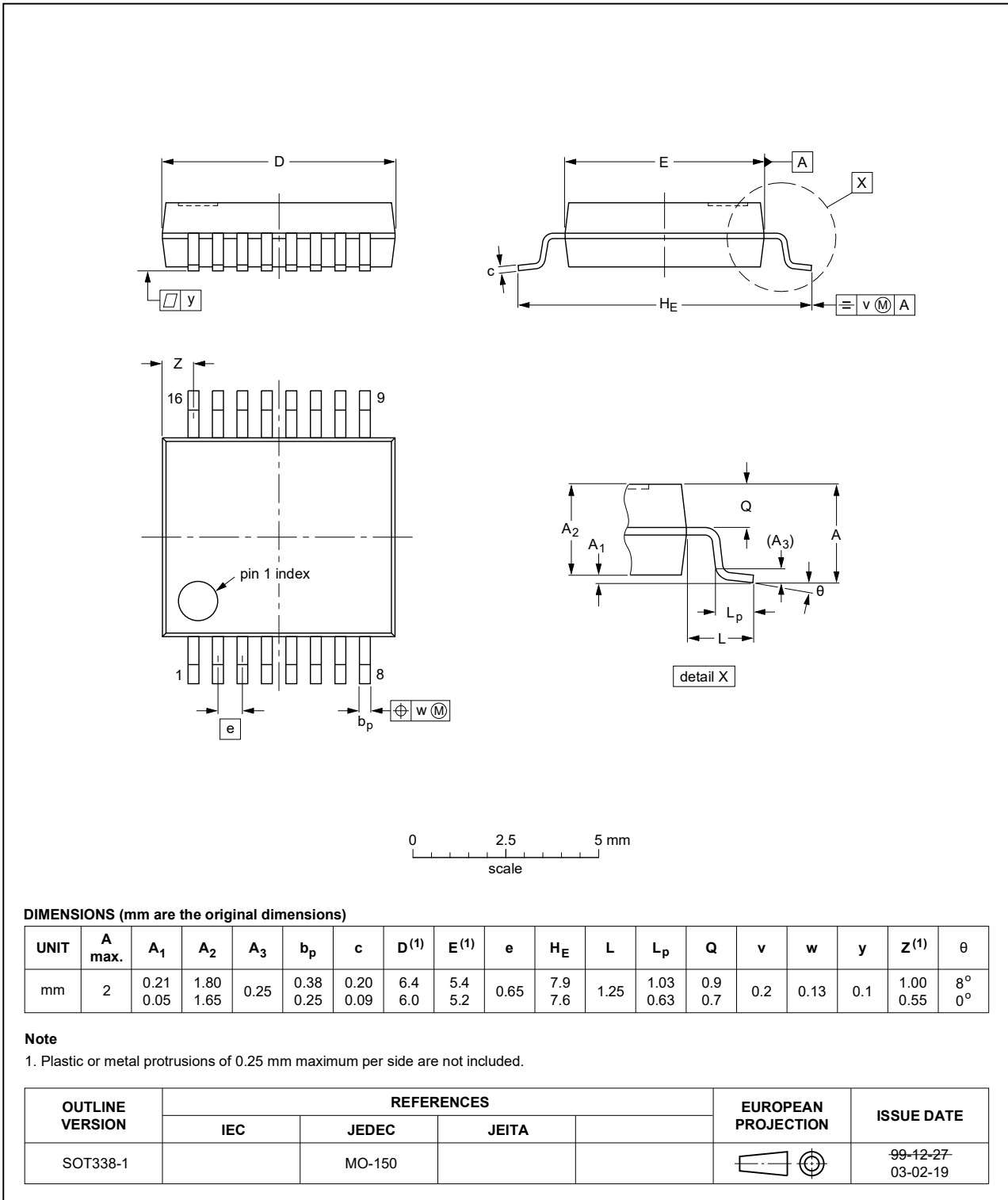


Fig. 19. Package outline SOT338-1 (SSOP16)

TSSOP16: plastic thin shrink small outline package; 16 leads; body width 4.4 mm

SOT403-1



Fig. 20. Package outline SOT403-1 (TSSOP16)



DHVQFN16: plastic dual in-line compatible thermal enhanced very thin quad flat package; no leads; 16 terminals; body 2.5 x 3.5 x 0.85 mm

SOT763-1



Fig. 21. Package outline SOT763-1 (DHVQFN16)

## 14. Abbreviations

Table 9. Abbreviations

Acronym	Description
CMOS	Complementary Metal-Oxide Semiconductor
DUT	Device Under Test
ESD	ElectroStatic Discharge
HBM	Human Body Model
MIL	Military
MM	Machine Model
TTL	Transistor-Transistor Logic

## 15. Revision history

Table 10. Revision history

Document ID	Release date	Data sheet status	Change notice	Supersedes
74HC_HCT4060_Q100 v.3	20200508	Product data sheet	-	74HC_HCT4060_Q100 v.2
Modifications:	<ul style="list-style-type: none"> <li>The format of this data sheet has been redesigned to comply with the identity guidelines of Nexperia.</li> <li>Legal texts have been adapted to the new company name where appropriate.</li> <li><a href="#">Section 1</a> and <a href="#">Section 2</a> updated.</li> <li><a href="#">Fig. 2</a>: Pinnames corrected. (errata)</li> <li><a href="#">Table 3</a>: Derating values for <math>P_{tot}</math> total power dissipation updated.</li> <li><a href="#">Table 5</a>: HIGH and LOW input levels added for 74HCT4060-Q100. (errata)</li> <li>Type number 74HCT4060DB-Q100 (SSOP16/SOT338-1) removed.</li> </ul>			
74HC_HCT4060_Q100 v.2	20130410	Product data sheet	-	74HC_HCT4060_Q100 v.1
Modifications:	<ul style="list-style-type: none"> <li>74HC4060DB-Q100 and 74HCT4060DB-Q100 added.</li> </ul>			
74HC_HCT4060_Q100 v.1	20120802	Product data sheet	-	-

## 16. Legal information

### Data sheet status

Document status [1][2]	Product status [3]	Definition
Objective [short] data sheet	Development	This document contains data from the objective specification for product development.
Preliminary [short] data sheet	Qualification	This document contains data from the preliminary specification.
Product [short] data sheet	Production	This document contains the product specification.

- [1] Please consult the most recently issued document before initiating or completing a design.
- [2] The term 'short data sheet' is explained in section "Definitions".
- [3] The product status of device(s) described in this document may have changed since this document was published and may differ in case of multiple devices. The latest product status information is available on the internet at <https://www.nexperia.com>.

### Definitions

**Draft** — The document is a draft version only. The content is still under internal review and subject to formal approval, which may result in modifications or additions. Nexperia does not give any representations or warranties as to the accuracy or completeness of information included herein and shall have no liability for the consequences of use of such information.

**Short data sheet** — A short data sheet is an extract from a full data sheet with the same product type number(s) and title. A short data sheet is intended for quick reference only and should not be relied upon to contain detailed and full information. For detailed and full information see the relevant full data sheet, which is available on request via the local Nexperia sales office. In case of any inconsistency or conflict with the short data sheet, the full data sheet shall prevail.

**Product specification** — The information and data provided in a Product data sheet shall define the specification of the product as agreed between Nexperia and its customer, unless Nexperia and customer have explicitly agreed otherwise in writing. In no event however, shall an agreement be valid in which the Nexperia product is deemed to offer functions and qualities beyond those described in the Product data sheet.

### Disclaimers

**Limited warranty and liability** — Information in this document is believed to be accurate and reliable. However, Nexperia does not give any representations or warranties, expressed or implied, as to the accuracy or completeness of such information and shall have no liability for the consequences of use of such information. Nexperia takes no responsibility for the content in this document if provided by an information source outside of Nexperia.

In no event shall Nexperia be liable for any indirect, incidental, punitive, special or consequential damages (including - without limitation - lost profits, lost savings, business interruption, costs related to the removal or replacement of any products or rework charges) whether or not such damages are based on tort (including negligence), warranty, breach of contract or any other legal theory.

Notwithstanding any damages that customer might incur for any reason whatsoever, Nexperia's aggregate and cumulative liability towards customer for the products described herein shall be limited in accordance with the Terms and conditions of commercial sale of Nexperia.

**Right to make changes** — Nexperia reserves the right to make changes to information published in this document, including without limitation specifications and product descriptions, at any time and without notice. This document supersedes and replaces all information supplied prior to the publication hereof.

**Suitability for use in automotive applications** — This Nexperia product has been qualified for use in automotive applications. Unless otherwise agreed in writing, the product is not designed, authorized or warranted to be suitable for use in life support, life-critical or safety-critical systems or

equipment, nor in applications where failure or malfunction of an Nexperia product can reasonably be expected to result in personal injury, death or severe property or environmental damage. Nexperia and its suppliers accept no liability for inclusion and/or use of Nexperia products in such equipment or applications and therefore such inclusion and/or use is at the customer's own risk.

**Quick reference data** — The Quick reference data is an extract of the product data given in the Limiting values and Characteristics sections of this document, and as such is not complete, exhaustive or legally binding.

**Applications** — Applications that are described herein for any of these products are for illustrative purposes only. Nexperia makes no representation or warranty that such applications will be suitable for the specified use without further testing or modification.

Customers are responsible for the design and operation of their applications and products using Nexperia products, and Nexperia accepts no liability for any assistance with applications or customer product design. It is customer's sole responsibility to determine whether the Nexperia product is suitable and fit for the customer's applications and products planned, as well as for the planned application and use of customer's third party customer(s). Customers should provide appropriate design and operating safeguards to minimize the risks associated with their applications and products.

Nexperia does not accept any liability related to any default, damage, costs or problem which is based on any weakness or default in the customer's applications or products, or the application or use by customer's third party customer(s). Customer is responsible for doing all necessary testing for the customer's applications and products using Nexperia products in order to avoid a default of the applications and the products or of the application or use by customer's third party customer(s). Nexperia does not accept any liability in this respect.

**Limiting values** — Stress above one or more limiting values (as defined in the Absolute Maximum Ratings System of IEC 60134) will cause permanent damage to the device. Limiting values are stress ratings only and (proper) operation of the device at these or any other conditions above those given in the Recommended operating conditions section (if present) or the Characteristics sections of this document is not warranted. Constant or repeated exposure to limiting values will permanently and irreversibly affect the quality and reliability of the device.

**Terms and conditions of commercial sale** — Nexperia products are sold subject to the general terms and conditions of commercial sale, as published at <http://www.nexperia.com/profile/terms>, unless otherwise agreed in a valid written individual agreement. In case an individual agreement is concluded only the terms and conditions of the respective agreement shall apply. Nexperia hereby expressly objects to applying the customer's general terms and conditions with regard to the purchase of Nexperia products by customer.

**No offer to sell or license** — Nothing in this document may be interpreted or construed as an offer to sell products that is open for acceptance or the grant, conveyance or implication of any license under any copyrights, patents or other industrial or intellectual property rights.

**Export control** — This document as well as the item(s) described herein may be subject to export control regulations. Export might require a prior authorization from competent authorities.

**Translations** — A non-English (translated) version of a document is for reference only. The English version shall prevail in case of any discrepancy between the translated and English versions.

### Trademarks

Notice: All referenced brands, product names, service names and trademarks are the property of their respective owners.

## Contents

---

<b>1. General description</b> .....	<b>1</b>
<b>2. Features and benefits</b> .....	<b>1</b>
<b>3. Applications</b> .....	<b>1</b>
<b>4. Ordering information</b> .....	<b>2</b>
<b>5. Functional diagram</b> .....	<b>2</b>
<b>6. Pinning information</b> .....	<b>3</b>
6.1. Pinning.....	3
6.2. Pin description.....	3
<b>7. Functional description</b> .....	<b>4</b>
<b>8. Limiting values</b> .....	<b>4</b>
<b>9. Recommended operating conditions</b> .....	<b>5</b>
<b>10. Static characteristics</b> .....	<b>5</b>
<b>11. Dynamic characteristics</b> .....	<b>8</b>
11.1. Waveforms and test circuit.....	10
<b>12. RC oscillator</b> .....	<b>11</b>
12.1. Timing component limitations.....	11
12.2. Typical crystal oscillator circuit.....	12
<b>13. Package outline</b> .....	<b>14</b>
<b>14. Abbreviations</b> .....	<b>18</b>
<b>15. Revision history</b> .....	<b>18</b>
<b>16. Legal information</b> .....	<b>19</b>

---

© Nexperia B.V. 2020. All rights reserved

For more information, please visit: <http://www.nexperia.com>  
For sales office addresses, please send an email to: [salesaddresses@nexperia.com](mailto:salesaddresses@nexperia.com)  
**Date of release: 8 May 2020**

---

Компания «Life Electronics» занимается поставками электронных компонентов импортного и отечественного производства от производителей и со складов крупных дистрибьюторов Европы, Америки и Азии.

С конца 2013 года компания активно расширяет линейку поставок компонентов по направлению коаксиальный кабель, кварцевые генераторы и конденсаторы (керамические, пленочные, электролитические), за счёт заключения дистрибьюторских договоров

Мы предлагаем:

- Конкуренспособные цены и скидки постоянным клиентам.
- Специальные условия для постоянных клиентов.
- Подбор аналогов.
- Поставку компонентов в любых объемах, удовлетворяющих вашим потребностям.
- Приемлемые сроки поставки, возможна ускоренная поставка.
- Доставку товара в любую точку России и стран СНГ.
- Комплексную поставку.
- Работу по проектам и поставку образцов.
- Формирование склада под заказчика.
- Сертификаты соответствия на поставляемую продукцию (по желанию клиента).
- Тестирование поставляемой продукции.
- Поставку компонентов, требующих военную и космическую приемку.
- Входной контроль качества.
- Наличие сертификата ISO.

В составе нашей компании организован Конструкторский отдел, призванный помогать разработчикам, и инженерам.

Конструкторский отдел помогает осуществить:

- Регистрацию проекта у производителя компонентов.
- Техническую поддержку проекта.
- Защиту от снятия компонента с производства.
- Оценку стоимости проекта по компонентам.
- Изготовление тестовой платы монтаж и пусконаладочные работы.



Тел: +7 (812) 336 43 04 (многоканальный)  
Email: [org@lifeelectronics.ru](mailto:org@lifeelectronics.ru)