

Devices Connected/Referenced

AD5750-1	Industrial Current/Voltage Output Driver with Programmable Ranges
AD5660-1	16-Bit nanoDAC® Digital-to-Analog Converter with 5 ppm/°C On-Chip Reference in SOT-23

Flexible PLC/DCS Analog Output Module Using Only Two Analog Components

EVALUATION AND DESIGN SUPPORT

Circuit Evaluation Boards

[CN-0203 Circuit Evaluation Board \(EVAL-CN0203-SDPZ\)](#)

[System Demonstration Platform \(EVAL-SDP-CB1Z\)](#)

Design and Integration Files

[Schematics, Layout Files, Bill of Materials](#)

CIRCUIT FUNCTION AND BENEFITS

The circuit shown in Figure 1 provides a full function, flexible, programmable analog output solution with only two analog components and meets most requirements for programmable logic controller (PLC) and distributed control system (DCS)

applications. The AD5660-1 low power (2.8 mW @ 5 V), rail-to-rail output, 16-bit nanoDAC®, combined with the AD5750-1 industrial current/voltage output driver, provides all the typical current and voltage output ranges with 16-bit resolution and no missing codes, 0.05% linearity, and less than 0.1% output error. The circuit also contains key features for industrial applications, such as on-chip output fault detection, CRC checking to prevent packet error (PEC), and flexible power-up options, making it an ideal choice for robust industrial control systems. No external precision resistors or calibration routines are needed to maintain consistent performance in mass production, thereby making it ideal for PLC or DCS modules.

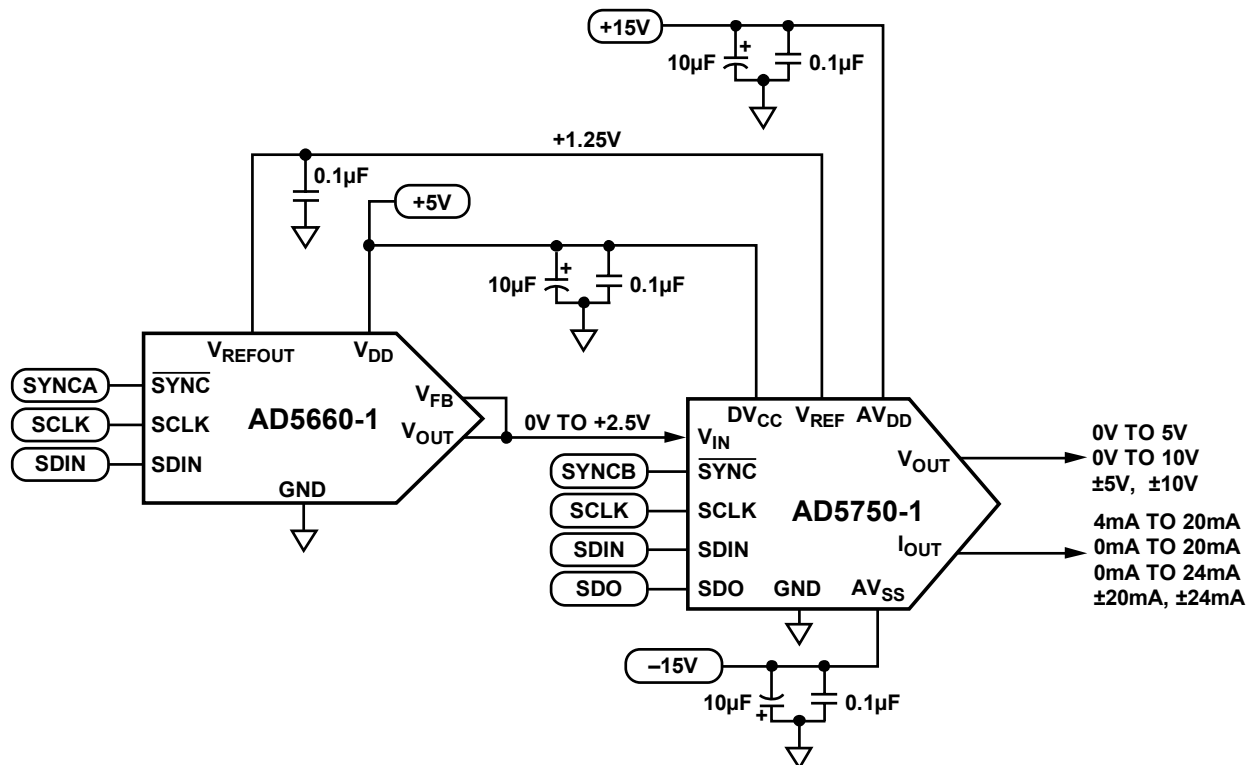

Figure 1. Basic Analog Output Circuit for Single Channel (Simplified Schematic, All Connections and Protection Circuits Not Shown)

Rev.A

Circuits from the Lab™ circuits from Analog Devices have been designed and built by Analog Devices engineers. Standard engineering practices have been employed in the design and construction of each circuit, and their function and performance have been tested and verified in a lab environment at room temperature. However, you are solely responsible for testing the circuit and determining its suitability and applicability for your use and application. Accordingly, in no event shall Analog Devices be liable for direct, indirect, special, incidental, consequential or punitive damages due to any cause whatsoever connected to the use of any Circuits from the Lab circuits. (Continued on last page)

CIRCUIT DESCRIPTION

The **AD5750/AD5750-1** are single-channel, low cost, precision voltage/current output drivers developed to meet the requirements of industrial process control applications. The voltage output range can be programmed for the standard output ranges for PLC and DCS applications: 0 V to 5 V, 0 V to 10 V, -5 V to +5 V, and -10 V to +10 V. A 20% overrange setting is also provided for the standard ranges, giving the following options: 0 V to 6 V, 0 V to 12 V, -6 V to +6 V, and -12 V to +12 V.

The current output, which is provided on a separate pin, can be programmed for the ranges of 4 mA to 20 mA, 0 mA to 20 mA, -20 mA to +20 mA, 0 mA to 24 mA, and -24 mA to +24 mA. The unipolar ranges have a 2% overrange setting. Because the **AD5750/AD5750-1** current output can either source or sink current, it can interface to a wide variety of sensors or actuators. The voltage and current output pins can be tied together to configure the end system as a single-channel output if desired.

The **AD5660-1** is a single channel, low cost, low power, rail-to-rail voltage buffered output nanoDAC integrated with an on-chip 1.25 V, 5 ppm/°C reference. The **AD5660-1** incorporates a power-on reset circuit to ensure that the DAC output powers up to 0 V and remains there until a valid write command takes place.

The interface between the **AD5660-1** DAC and the **AD5750-1** driver is simple and requires no external components. The output voltage range of the **AD5660-1** is 0 V to 2.5 V, which matches the input range of the **AD5750-1**. In addition, the reference output voltage of the **AD5660-1** is 1.25 V, which precisely matches the reference input requirement of the **AD5750-1**.

Devices for PLC and DCS applications generally need ESD protection and overvoltage protection much higher than the formal recommend specifications. The **AD5750-1** has integrated ESD protection diodes internal to each pin that can prevent damage from a 3 kV transient (Human Body Model). However, the industrial control environment can subject I/O circuits to much higher transients. External 30 V, 600 W transient voltage suppressors (TVS), a 50 mA, 30 V PolySwitch, and power Schottky diodes are built into the EVAL-CN0203-SDPZ circuit board to provide higher voltage ESD protection, 50 mA overcurrent, and 30 V overvoltage protection. The optional external protection circuits are not shown in the simplified schematic of Figure 1 but can be found in the detailed schematic (EVAL-CN0203-SDPZ-SCH pdf file) in the CN0203 Design Support package: www.analog.com/CN0203-DesignSupport.

The circuit must be constructed on a multilayer PC board with a large area ground plane. Proper layout, grounding, and decoupling techniques must be used to achieve optimum performance (see [Tutorial MT-031, Grounding Data Converters](#)

and [Solving the Mystery of "AGND" and "DGND,"](#) and [Tutorial MT-101, Decoupling Techniques](#)).

Measurements

Integral nonlinearity (INL), differential nonlinearity (DNL), and output error are the most important specifications for PLC, DCS, and other process control systems. The **AD5750-1** has highly flexible and configurable output ranges that can be tailored to meet the needs of the application. Measurements of INL, DNL, and output error for the circuit are shown in Figure 2, Figure 3, and Figure 4, respectively. This data was taken at 25°C in the voltage output mode using the internal current sense resistor. The **AD5750-1** range was set for 0 V to 5 V. The test results for all the other ranges are listed in Table 1.

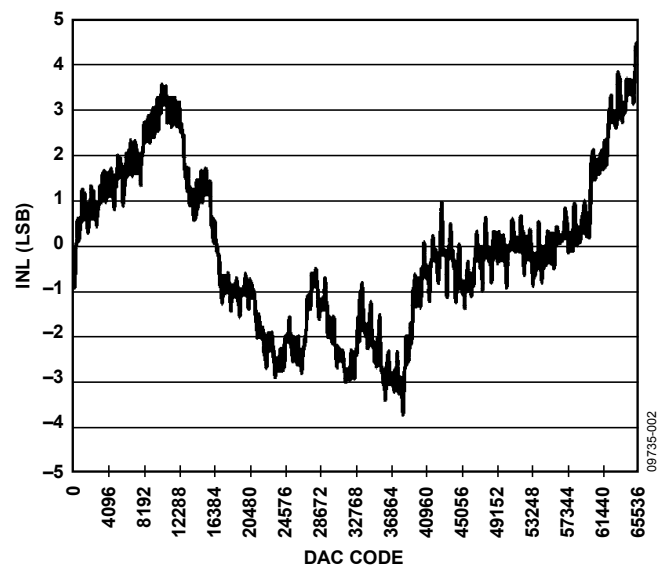

Figure 2. INL for 0 V to 5 V Output Range

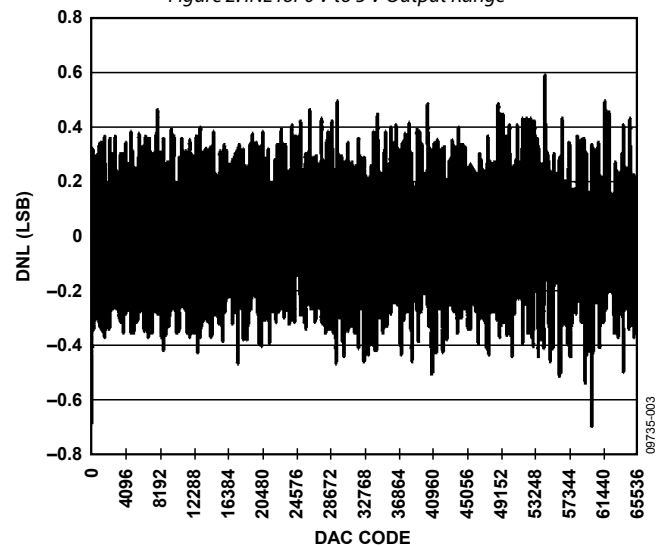

Figure 3. DNL for 0 V to 5 V Output Range

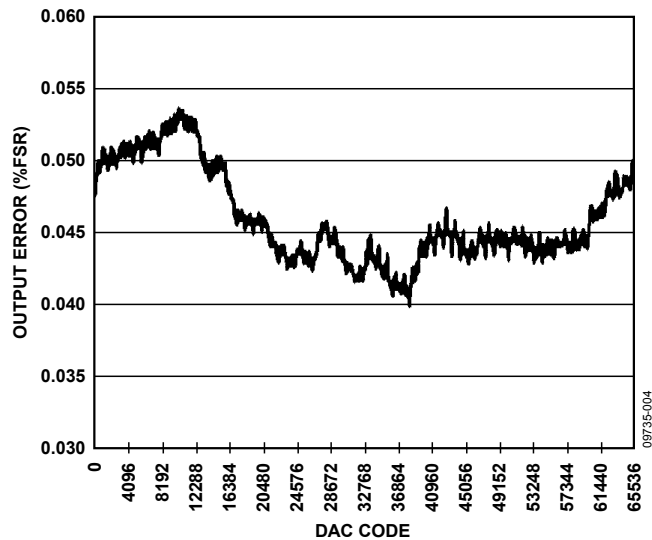

Figure 4. Output Error for 0 V to 5 V Output Range

The test results shown in Table 1 were made at 25°C using the EVAL-CN0203-SDPZ board powered by an Agilent E3631A dc supply and measured with an Agilent 34401A digital multimeter.

Note that the output ranges 0 mA to 20.4 mA and 0 mA to 24.5 mA are both designed to be trimmed by the customer to precisely match the 0 mA to 20 mA and 0 mA to 24 mA ranges. The 0.24% FSR output error measurement in the 0 mA to +24.5 mA range includes the gain error, which is removed by customer calibration.

Table 1. Test Results for All Output Ranges

Range	Current Sense Resistor	INL (LSB)	Linearity (%FSR)	Oupput Error (%FSR)
0 V to 5 V	Don't care	7.1	0.011	0.05
0 V to 10 V	Don't care	6.1	0.009	0.05
-5 V to +5 V	Don't care	6.2	0.009	0.04
-10 V to +10 V	Don't care	6.8	0.010	0.04
0 V to 6 V	Don't care	6.9	0.010	0.05
0 V to 12 V	Don't care	5.3	0.008	0.09
-6 V to +6 V	Don't care	8.0	0.012	0.06
-12 V to +12 V	Don't care	7.4	0.011	0.08
-2.5 V to +2.5 V	Don't care	5.6	0.008	0.05
4 mA to 20 mA	Internal	6.3	0.010	0.07
4 mA to 20 mA	External	6.2	0.010	0.07
0 mA to 20 mA	Internal	5.8	0.009	0.06
0 mA to 20 mA	External	5.7	0.009	0.06
0 mA to 24 mA	Internal	5.4	0.008	0.07
0 mA to 24 mA	External	5.5	0.008	0.06
-20 mA to +20 mA	Internal	8.8	0.013	0.05
-20 mA to +20 mA	External	9.3	0.014	0.05
-24 mA to +24 mA	Internal	9.2	0.014	0.05
-24 mA to +24 mA	External	10.1	0.015	0.04
3.92 mA to +20.4 mA	Internal	6.7	0.010	0.03
0 mA to +20.4 mA	Internal	7.6	0.012	0.05
0 mA to +24.5 mA	Internal	3.4	0.007	0.24

COMMON VARIATIONS

The [AD5620](#) (12-bit) and [AD5640](#) (14-bit) are pin-compatible with the [AD5660](#) for applications not requiring 16-bit resolution.

For multichannel applications, the [AD5623R](#) (12-bit), [AD5643R](#) (14-bit), and [AD5663R](#) (16-bit) are dual nanoDAC devices, and the [AD5624R](#) (12-bit), [AD5644R](#) (14-bit), and [AD5664R](#) (16-bit) are quad nanoDAC devices.

The [AD5750](#) driver is pin-compatible with the [AD5750-1](#) and can accept a 0 V to 4.096 V input range when used with a 4.096 V reference. The [AD5751](#) is a unipolar analog output driver and can supply a 40 V output using a 50 V AVDD supply.

CIRCUIT EVALUATION AND TEST

Equipment Needed (Equivalents Can Be Substituted)

- System Demonstration Platform (EVAL-SDP-CB1Z)
- CN-0203 Circuit Evaluation Board (EVAL-CN0203-SDPZ)
- CN-0203 Evaluation Software
- Software for controlling external test measurement equipment (not included on CD)
- Agilent 34401A 6.5 Digital Multimeter
- Agilent E3631A 0 V to 6 V/5 A; ± 25 V/1 A Triple Output DC Power Supply
- PC (Windows® 2000 or Windows XP) with USB interface
- National Instruments GPIB to USB-B interface and cable

Getting Started

Load the evaluation software by placing the CN-0203 Evaluation Software disc in the CD drive of the PC. Using "My Computer," locate the drive that contains the evaluation software disc and open the Readme file. Follow the instructions contained in the Readme file for installing and using the evaluation software.

Functional Block Diagram

Figure 5 shows a functional block diagram of the test setup. The pdf file "EVAL-CN0203-SDPZ-SCH" contains the detailed circuit schematics for the CN-0203 evaluation board. This file is contained in the CN-0203 Design Support Package: www.analog.com/CN0203-DesignSupport.

Setup

Connect the 120-pin connector on the EVAL-CN0203-SDPZ circuit board to the connector marked "CON A" or "CON B" on the EVAL-SDP-CB1Z evaluation (SDP) board. Nylon hardware should be used to firmly secure the two boards, using the holes provided at the ends of the 120-pin connectors. After successfully setting the dc output supply to +15 V, -15 V and +6 V output, turn the power supply off.

With power to the supply off, connect a +15 V power supply to pin of CN1 marked "+15 V," a -15 V power supply to the pin of CN1 marked "-15 V" and "GND" to the pin of CN1 marked "GND". Connect +6 V to CN2 the same way. Turn on the power supply and then connect USB cable with the SDP board to the USB port on the PC. Note: Do not connect the USB cable to the mini USB connector on the SDP board before turning on the dc power supply for the EVAL-CN0203-SDPZ.

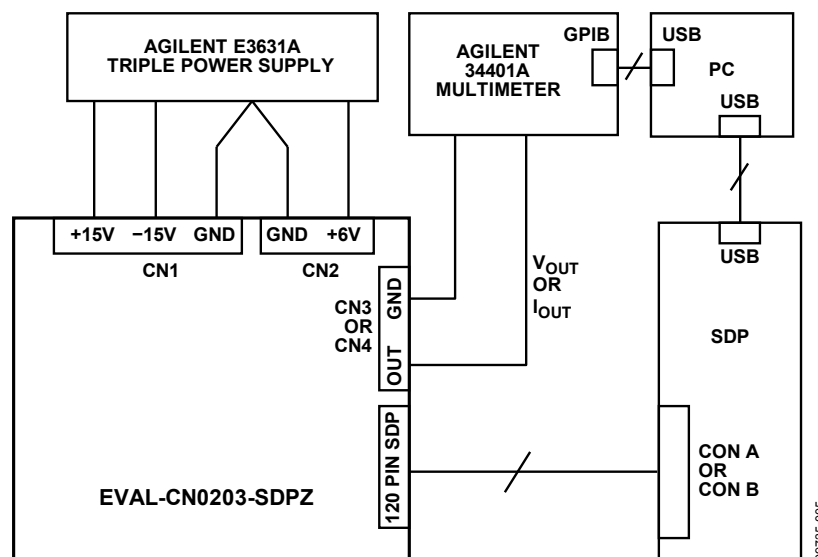

Figure 5. Test Setup Functional Block Diagram

Table 2. Jumper Settings for EVAL-CN0203-SDPZ (Bolded Values Are Default Settings)

Jumper	Descriptions	Setting	Function
JP1	Sets the address of AD5750-1	Shorting Pin1 with Pin2	Address of AD5750 : b'001
		Shorting Pin3 with Pin2	Address of AD5750 : b'000
JP2	Sets the external compensation capacitor	Shorting	Adding 1 nF Compensation Capacitor
		Opening	Removing 1 nF Compensation Capacitor
JP3	VSENSE+ Setting	Shorting	Shorting VSENSE+ with VOUT internally
		Opening	VSENSE+ has no connection with VOUT internally
JP4	VSENSE- Setting	Shorting	Shorting VSENSE- with GND internally
		Opening	VSENSE- has no connection with GND internally
JP5	Shorts the VOUT and IOOUT pins	Shorting	Shorts VOUT and IOOUT together.
		Opening	VOUT and IOOUT have no connection internally
JP6	Sets the CLEAR Mode for AD5750-1	Shorting	Clears to midscale
		Opening	Clears to zero scale

Test

After setting up the test equipment, connect the pin of CN3 marked “VOUT” or the pin of CN4 marked “IOOUT” to the input of the Agilent 34401A. Make sure that the cable connection on the front panel of the Agilent 34401A is correct, depending on the different input signal type (current or voltage). Testing the INL, DNL, and total error will take a considerable amount of time because all of the [AD5660-1](#) 16-bit DAC levels must be set and measured by the 34401A.

The software provided on the CD allows the DAC codes to be set by the PC. An automatic test program is necessary to step through the codes and analyze the data. This is not provided on the CD but must be implemented by the customer to correspond to the requirements of the particular multimeter used in the test setup.

In the test configuration shown in Figure 5, the GPIB output of the 34401A multimeter interfaces to a second USB port on the PC using the National Instruments GPIB to USB-B interface and cable. This allows the multimeter readings corresponding to each code to be loaded into an Excel spreadsheet in the PC. The data is then be analyzed for INL, DNL, and total error using industry-standard definitions.

For more details on the definitions and how to calculate the INL, DNL, and total error from the measured data, see the “TERMINOLOGY” section of the [AD5662 data sheet](#) and also the following reference: *Data Conversion Handbook*, “Testing Data Converters,” Chapter 5, Analog Devices.

LEARN MORE

CN-0203 Design Support Package:

www.analog.com/CN0203-DesignSupport

Slattery, Colm, Derrick Hartmann, and Li Ke, “PLC Evaluation Board Simplifies Design of Industrial Process Control Systems.” *Analog Dialogue* (April 2009).

CN-0063 Circuit Note, *16-Bit Fully Isolated Voltage Output Module Using the AD5662 DAC, ADuM1401 Digital Isolator, and External Amplifiers*, Analog Devices.

CN-0064 Circuit Note, *16-Bit Fully Isolated 4 mA to 20 mA Output Module Using the AD5662 DAC, ADuM1401 Digital Isolator, and External Amplifiers*, Analog Devices.

CN-0065 Circuit Note, *16-Bit Fully Isolated Output Module Using the AD5422 Single Chip Voltage and Current Output DAC and the ADuM1401 Digital Isolator*, Analog Devices.

CN-0066 Circuit Note, *Fully Isolated Input Module Based on the AD7793 24-Bit Σ - Δ ADC and the ADuM5401 Digital Isolator*, Analog Devices.

CN-0067 Circuit Note, *Fully Isolated Input Module Based on the AD7793 24-Bit Σ - Δ ADC, the ADuM5401 Digital Isolator, and a High Performance In-Amp*, Analog Devices.

CN-0097 Circuit Note, *Simplified 12-Bit Voltage and 4 mA-to-20 mA Output Solution Using the AD5412*, Analog Devices.

CN-0209 Circuit Note, *Fully Programmable Universal Analog Front End for Process Control Applications*, Analog Devices.

MT-031 Tutorial, *Grounding Data Converters and Solving the Mystery of “AGND” and “DGND”*, Analog Devices.

MT-101 Tutorial, *Decoupling Techniques*, Analog Devices.
 Kester, Walt. *Practical Design Techniques for Sensor Signal Conditioning, Analog Devices*, 1999, ISBN 0-916550-20-6
 Kester, Walt. *Data Conversion Handbook*, Chapter 5, Analog Devices.

Data Sheets and Evaluation Boards

CN-0203 Circuit Evaluation Board (EVAL-CN0203-SDPZ)
 System Demonstration Platform (EVAL-SDP-CB1Z)
 AD5750-1 Data Sheet
 AD5750-1 Evaluation Board
 AD5660-1 Data Sheet
 AD5660-1 Evaluation Board
 AD5662 Data Sheet

REVISION HISTORY

11/11—Rev. 0 to Rev. A
 Change to Table 13
 9/11—Revision 0: Initial Version

(Continued from first page) Circuits from the Lab circuits are intended only for use with Analog Devices products and are the intellectual property of Analog Devices or its licensors. While you may use the Circuits from the Lab circuits in the design of your product, no other license is granted by implication or otherwise under any patents or other intellectual property by application or use of the Circuits from the Lab circuits. Information furnished by Analog Devices is believed to be accurate and reliable. However, "Circuits from the Lab" are supplied "as is" and without warranties of any kind, express, implied, or statutory including, but not limited to, any implied warranty of merchantability, noninfringement or fitness for a particular purpose and no responsibility is assumed by Analog Devices for their use, nor for any infringements of patents or other rights of third parties that may result from their use. Analog Devices reserves the right to change any Circuits from the Lab circuits at any time without notice but is under no obligation to do so.



Компания «Life Electronics» занимается поставками электронных компонентов импортного и отечественного производства от производителей и со складов крупных дистрибьюторов Европы, Америки и Азии.

С конца 2013 года компания активно расширяет линейку поставок компонентов по направлению коаксиальный кабель, кварцевые генераторы и конденсаторы (керамические, пленочные, электролитические), за счёт заключения дистрибьюторских договоров

Мы предлагаем:

- Конкурентоспособные цены и скидки постоянным клиентам.
- Специальные условия для постоянных клиентов.
- Подбор аналогов.
- Поставку компонентов в любых объемах, удовлетворяющих вашим потребностям.
- Приемлемые сроки поставки, возможна ускоренная поставка.
- Доставку товара в любую точку России и стран СНГ.
- Комплексную поставку.
- Работу по проектам и поставку образцов.
- Формирование склада под заказчика.
- Сертификаты соответствия на поставляемую продукцию (по желанию клиента).
- Тестирование поставляемой продукции.
- Поставку компонентов, требующих военную и космическую приемку.
- Входной контроль качества.
- Наличие сертификата ISO.

В составе нашей компании организован Конструкторский отдел, призванный помогать разработчикам, и инженерам.

Конструкторский отдел помогает осуществить:

- Регистрацию проекта у производителя компонентов.
- Техническую поддержку проекта.
- Защиту от снятия компонента с производства.
- Оценку стоимости проекта по компонентам.
- Изготовление тестовой платы монтаж и пусконаладочные работы.



Тел: +7 (812) 336 43 04 (многоканальный)
Email: org@lifeelectronics.ru