

Next Generation VoiceEdge™ Control Processor Next Generation Carrier Chipset (NGCC)

APPLICATIONS

- Cost effective voice solution for long or short loops providing POTS and integrated test capabilities
- Applications include: IVD, DLC, CO, Voice-enabled DSLAM, PBX/KTS, MDU, MSAP, MSAN

FEATURES

- Aggregated call control lowers demand on host micro-processor
 - 128 channels of call control
- Provides expanded line and circuit testing in conjunction with Microsemi's NGCC chipset
 - Provides 4 channels of simultaneous line testing
- Software interface using VoicePath™ API-II
- Software downloadable, field upgradeable, expandable
- Serial and parallel host controller interface options
- Complete control of up to 16 Octal NGSLAC devices
 - Two master SPI ports
 - 32 General Purpose I/Os
 - 16 configured as chip selects
 - 16 configured for interrupts
- Two slave PCM highway ports
- Internal PLL and hardware network timing recovery for creating analog sampling clocks
- 3.3 V compliant I/O

DESCRIPTION

The Le79128 Next Generation VoiceEdge™ Control Processor (VCP) is a second generation platform that delivers enhanced call control, self-test and line test capabilities. This latest processor works with Microsemi NGCC devices using its SPI interfaces, PCM ports, and GPIO. The Le79128 device provides the same integrated line-testing and feature-set as the Le79112 device, plus additional capabilities such as 4 channels of simultaneous line testing and 128 channels of improved POTS control.

This product enables the design of a low-cost, high-performance, fully software programmable line interface with worldwide applicability. All AC, DC, and signaling parameters are programmable.

The Le79128 device is provided with extensive software and support, through the LineCare™ software suite, enabling the designer to develop a fully programmable solution in the least amount of time.

RELATED LITERATURE

- 139366 Le79128-SW NGVCP Software Data Sheet
- 081555 Le79271 NGSLIC Data Sheet
- 138884 Le79272 Dual NGSLIC Data Sheet
- 081193 Le79238 Octal NGSLAC Data Sheet
- 136868 ZL79258 Octal Ext Ringing NGSLAC Data Sheet
- 126583 NGCC Hardware Design Guide
- VoicePath™ API II Reference Guide

ORDERING INFORMATION

Device	Package	Packing
Le79128KVC	128-pin TQFP (Green) ¹	Tray
Le79128KVCT	128-pin TQFP (Green) ¹	Tape & Reel
ZL79128GDG2	144-pin LPGA ²	Tray

1. The green package meets RoHS Directive 2002/95/EC of the European Council to minimize the environmental impact of electrical equipment.
2. The LPGA package is RoHS-6 compliant.

BLOCK DIAGRAM

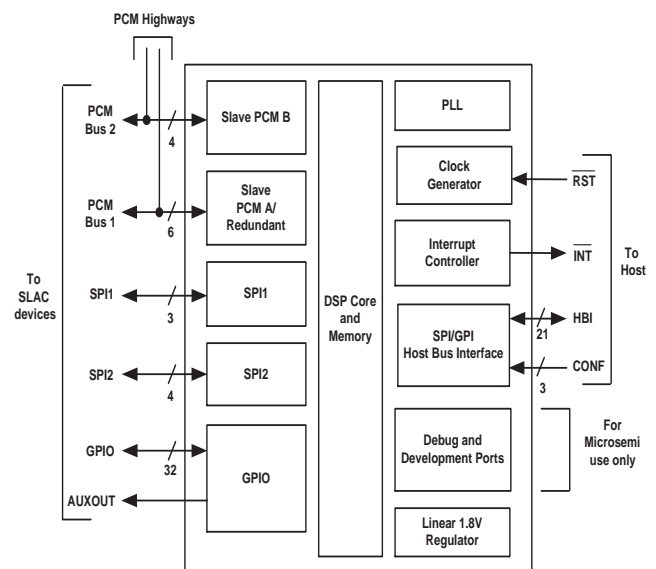

Document ID#: 139365 Date: Nov 7, 2011
Version 2 Protected Document

TABLE OF CONTENTS

Applications1
Features1
Ordering Information1
Description1
Related Literature1
Block Diagram1
Table of Contents2
Connection Diagrams3
Pin Descriptions6
Electrical Characteristics11
Absolute Maximum Ratings11
Operating Ranges11
DC Specifications12
Host Bus Interface (HBI) Overview13
Transport Layer14
Interface Addressing14
Command Structure15
VCP Direct Page Hardware Register Summary17
Direct Page (Hardware) Registers18
Code Loading26
Host Boot Procedure26
Application Layer27
Software (Application Derived) Registers27
Physical Layer28
General Purpose Parallel Interface (GPI)28
Serial Peripheral Interface (SPI)36
SPI1 and SPI2 Timing42
PCM Interface43
The VCP Device Interrupt Report and Service Mechanism45
Debug Interface46
Timing Diagram Test Points46
Troubleshooting at Initial Start-up47
Physical Dimensions48
128-Pin TQFP48
144-Pin LBGA49
Revision History50
Version 1 to Version 250

CONNECTION DIAGRAMS

Figure 1. Le79128KVC 128-Pin TQFP Package

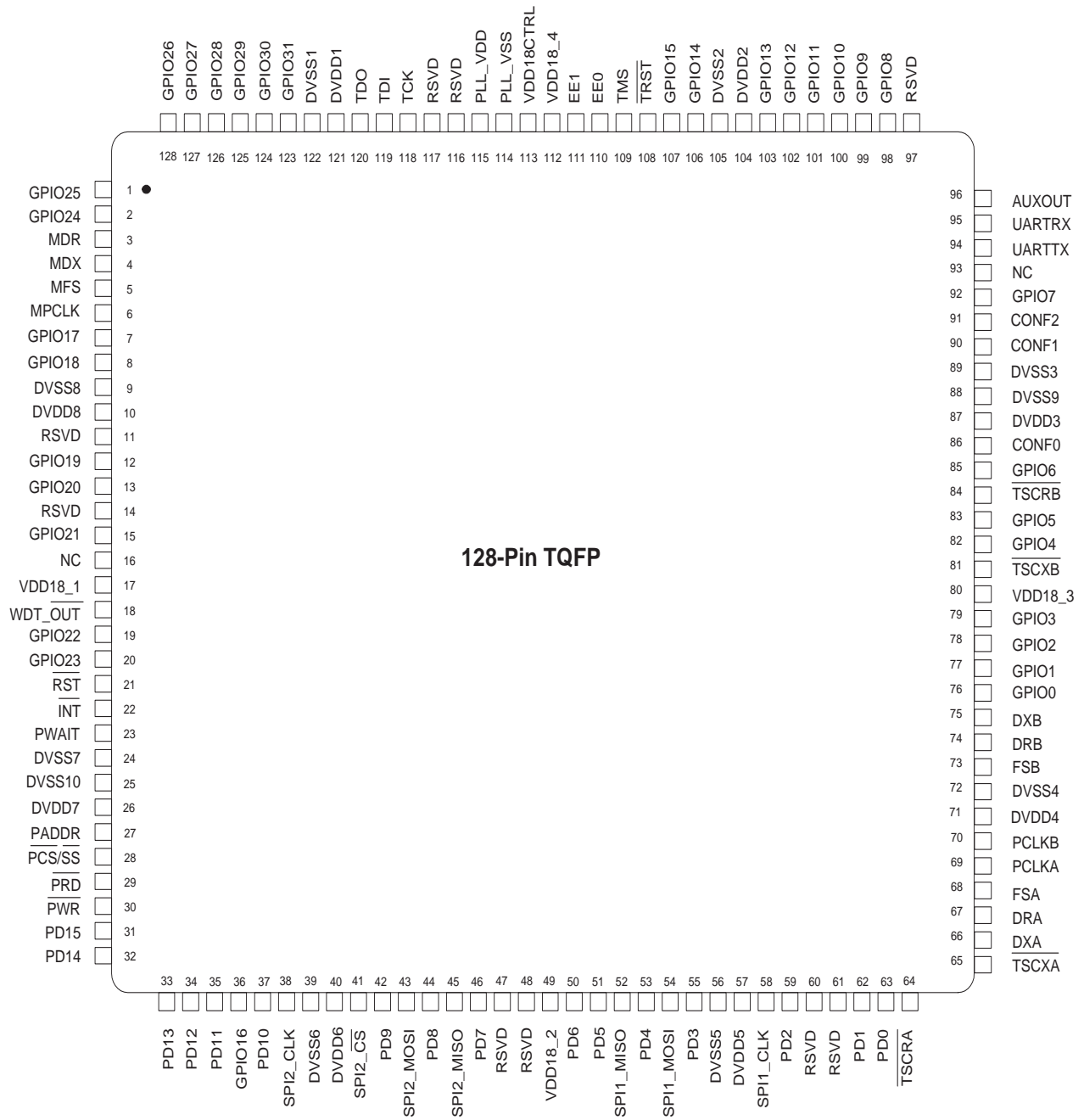
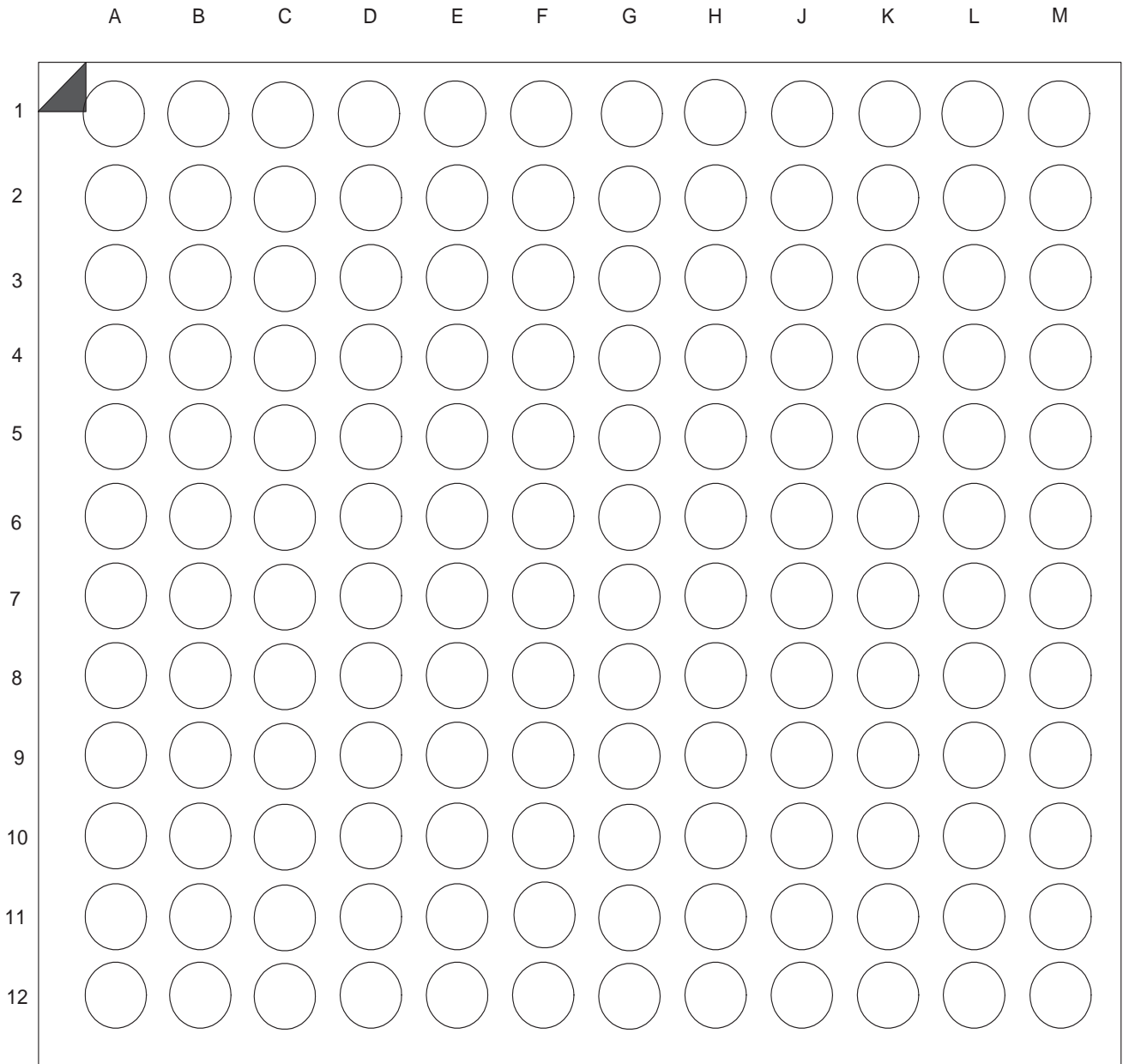

Figure 2. ZL79128GDG2 144-Pin LPGA Diagram



BOTTOM VIEW

Table 1. ZL79128GDG2 144-Pin LBGA Pin Numbers and Pin Names

LBGA Pin #	Pin Name	LBGA Pin #	Pin Name	LBGA Pin #	Pin Name	LBGA Pin #	Pin Name
A1	MDR	D1	MPCLK	G1	DVSS1	K1	$\overline{\text{PRD}}$ (PRD/ $\overline{\text{WR}}$ or SI)
A2	GPIO24	D2	GPIO18	G2	GPIO21	K2	$\overline{\text{PWR}}$ ($\overline{\text{PDS}}$ or SCK)
A3	GPIO26	D3	GPIO28	G3	DVDD1	K3	$\overline{\text{PCS}}/\overline{\text{SS}}$
A4	RSVD	D4	DVDD2	G4	VDD18_1	K4	PD ₉
A5	TDO	D5	DVSS4	G5	NC	K5	PD ₆
A6	PLL_VDD	D6	VDD18_2	G6	VDD18_3	K6	PD ₃
A7	VDD18CTRL	D7	DVSS7	G7	NC	K7	PD ₀
A8	GPIO15	D8	DVSS9	G8	NC	K8	SPI2_CLK
A9	GPIO14	D9	VDD18_5	G9	DVSS12	K9	SPI2_ $\overline{\text{CS}}$
A10	GPIO11	D10	GPIO6	G10	VDD18_6	K10	SPI1_CLK
A11	GPIO9	D11	GPIO7	G11	GPIO1	K11	$\overline{\text{TSCRA}}$
A12	RSVD	D12	CONF1	G12	GPIO2	K12	FSA
B1	MDX	E1	RSVD	H1	$\overline{\text{RST}}$	L1	PD ₁₅
B2	GPIO25	E2	GPIO19	H2	$\overline{\text{INT}}$	L2	PD ₁₃
B3	GPIO27	E3	GPIO22	H3	GPIO16	L3	PD ₁₁
B4	RSVD	E4	DVDD3	H4	DVSS3	L4	PD ₈
B5	TDI	E5	NC	H5	NC	L5	PD ₅
B6	TCK	E6	NC	H6	NC	L6	PD ₂
B7	PLL_VSS	E7	NC	H7	NC	L7	AUXOUT
B8	EE0	E8	NC	H8	NC	L8	RSVD
B9	GPIO13	E9	DVDD6	H9	DVDD7	L9	SPI2_MISO
B10	GPIO10	E10	$\overline{\text{TSCRB}}$	H10	GPIO0	L10	SPI1_MISO
B11	GPIO8	E11	GPIO5	H11	DRB	L11	$\overline{\text{TSCXA}}$
B12	RSVD	E12	CONF0	H12	FSB	L12	DRA
C1	MFS	F1	RSVD	J1	$\overline{\text{WDT_OUT}}$	M1	PD ₁₄
C2	GPIO17	F2	GPIO20	J2	PADDR	M2	PD ₁₂
C3	GPIO29	F3	GPIO23	J3	PWAIT	M3	PD ₁₀
C4	GPIO30	F4	DVSS2	J4	DVDD4	M4	PD ₇ (SO)
C5	GPIO31	F5	NC	J5	DVSS5	M5	PD ₄
C6	TMS	F6	DVDD5	J6	DVSS6	M6	PD ₁
C7	$\overline{\text{TRST}}$	F7	DVSS8	J7	VDD18_4	M7	RSVD
C8	EE1	F8	NC	J8	DVSS10	M8	RSVD
C9	GPIO12	F9	DVSS11	J9	DVDD8	M9	SPI2_MOSI
C10	UARTRX	F10	$\overline{\text{TSCXB}}$	J10	NC	M10	SPI1_MOSI
C11	UARTTX	F11	GPIO3	J11	DXB	M11	PCLKB
C12	CONF2	F12	GPIO4	J12	PCLKA	M12	DXA

PIN DESCRIPTIONS

Refer to the *Next Generation Carrier Chipset Hardware Design Guide (Document ID 126583)* for an Application Circuit and Parts List of external components.

All signals are CMOS levels unless otherwise stated.

Table 2. Le79128 VCP Device Pin Description (Host Interface Pins)

Pin Name (Alternate)	TQFP Pin #	LBGA Pin #	Type	Reset ¹	Description
CONF ₂	91	C12	Input	Z	VCP configuration pins that determine serial or parallel modes (8-bit, 16-bit, separate read and write strobes, data strobe and combined read/write strobe). See Table 8 for configuration summary.
CONF ₁	90	D12	Input	Z	
CONF ₀	86	E12	Input	Z	
$\overline{\text{PCS}}/\overline{\text{SS}}$	28	K3	Input	Z	$\overline{\text{PCS}}$: Parallel interface: active-low chip select. $\overline{\text{SS}}$: Serial interface: active-low slave select.
$\overline{\text{PRD}}$ (PRD/ WR or SI)	29	K1	Input	Z	$\overline{\text{PRD}}$: Parallel Separate Rd/Wr strobe: active-low read strobe. PRD/ $\overline{\text{WR}}$: Parallel Combined Rd/Wr strobe: active-high read control/active-low write control. SI: Serial interface: data input.
$\overline{\text{PWR}}$ ($\overline{\text{PDS}}$ or SCK)	30	K2	Input	Z	$\overline{\text{PWR}}$: Parallel Separate Rd/Wr strobe: active-low write strobe $\overline{\text{PDS}}$: Parallel Combined Rd/Wr strobe: active-low data strobe. SCK: Serial interface: data clock.
PD ₁₅	31	L1	Input/ Output	Z/Keeper	16-bit parallel interface: bi-directional data bits 15-8. Serial interface: reserved.
PD ₁₄	32	M1			
PD ₁₃	33	L2			
PD ₁₂	34	M2			
PD ₁₁	35	L3			
PD ₁₀	37	M3			
PD ₉	42	K4			
PD ₈	44	L4			
PD ₇ (SO)	46	M4	Input/ Output	Z/Pull-down (Parallel) Z (Serial)	PD ₇ : Parallel interface: bi-directional data bit 7. SO: Serial interface: data output.
PD ₆	50	K5	Input/ Output	Z/Keeper	Parallel interface: bi-directional data bits 6 through 0. Serial interface: reserved.
PD ₅	51	L5			
PD ₄	53	M5			
PD ₃	55	K6			
PD ₂	59	L6			
PD ₁	62	M6			
PD ₀	63	K7			
PWAIT	23	J3	Output	Z	Parallel interface: programmable active-low or active-high signal to extend the current access cycle. PWAIT should be connected to a resistor pulled to the inactive state. If unused, let pin float. Serial interface: reserved.
PADDR	27	J2	Input	Z	Parallel interface: signal to indicate the start of a command sequence. Serial interface: reserved.
$\overline{\text{INT}}$	22	H2	Output	Z/Pull-up	Host Interrupt indicator (active low).

Table 3. Le79128 VCP Device Pin Description (PCM Interface Pins)

Pin Name	TQFP Pin #	LBGA Pin #	Reset ¹	Description	
PCLKA	69	J12	Z	Slave PCM Highway A	Clock input. Mutually exclusive with PCLKB operation.
FSA	68	K12	Z		Framing input. ² Mutually exclusive with FSB operation.
DXA	66	M12	Z		PCM data output. ³ Mutually exclusive with DXB operation.
DRA	67	L12	Z		PCM data input. ² Mutually exclusive with DRB operation.
$\overline{\text{TSCXA}}$	65	L11	Z		PCM data output tristate control. Mutually exclusive with $\overline{\text{TSCXB}}$ operation. This output is active low when DXA is transmitting. The output is open-drain and is normally inactive (high impedance). A pull-up load should be connected to DVDD. If output not used, leave node float.
$\overline{\text{TSCRA}}$	64	K11	Z		PCM data input tristate control. Mutually exclusive with $\overline{\text{TSCRB}}$ operation. This output is active low when DRA is transmitting. The output is open-drain and is normally inactive (high impedance). A pull-up load should be connected to DVDD. If output not used, leave node float.
PCLKB	70	M11	Z	Redundant Slave PCM Highway	Clock input. Mutually exclusive with PCLKA operation. If not used, tie pin to DVSS.
FSB	73	H12	Z		Framing input. ² Mutually exclusive with FSA operation. If not used, tie pin to DVSS.
DXB	75	J11	Z		PCM data output. ³ Mutually exclusive with DXA operation. If not used, tie pin to DVSS.
DRB	74	H11	Z		PCM data input. ² Mutually exclusive with DRA operation. If not used, tie pin to DVSS.
$\overline{\text{TSCXB}}$	81	F10	Z		PCM data output tristate control. Mutually exclusive with $\overline{\text{TSCXA}}$ operation. This output is active low when DXB is transmitting. The output is open-drain and is normally inactive (high impedance). A pull-up load should be connected to DVDD. If output not used, leave node float.
$\overline{\text{TSCRB}}$	84	E10	Z		PCM data input tristate control. Mutually exclusive with $\overline{\text{TSCRA}}$ operation. This output is active low when DRB is transmitting. The output is open-drain and is normally inactive (high impedance). A pull-up load should be connected to DVDD. If output not used, leave node float.
MPCLK	6	D1	Z	Slave PCM Highway B	Clock input. ² Framing input. ² PCM data output. ³ PCM data input. ² If not used, tie pin to DVSS.
MFS	5	C1	Z		
MDX	4	B1	Z		
MDR	3	A1	Z		

Slave PCM Highway A has a Redundant Slave PCM Highway which can be used in parallel to PCM Highway A. When enabled, the VCP will automatically switch between Highway A and Redundant when either highway suffers a system failure. Slave PCM Highway A, or the Redundant Slave PCM Highway, is programmed by selecting VP_OPTION_HWY_A from the API.

Slave PCM Highway B is required for 128 channel operation. Slave PCM Highway B is programmed by selecting VP_OPTION_HWY_B from the API. Refer to the *Next Generation Carrier Chipset Hardware Design Guide* for diagrams on supported PCM Highway usage.

Table 4. Le79128 VCP Device Pin Description (Debug and Development Ports)

Pin Name	TQFP Pin #	LBGA Pin #	Type	Reset ¹	Description	
$\overline{\text{TRST}}$	108	C7	Input	Pull-up	Debug reset input. Tie to DVSS through 1 K Ω resistor.	These pins are for Microsemi debug use only. Refer to the Debug Interface section for more information.
TCK	118	B6	Input	Pull-up	Debug clock input.	
TMS	109	C6	Input	Pull-up	Debug mode select input.	
TDI	119	B5	Input	Pull-up	Debug data input.	
TDO	120	A5	Output	Z	Debug data output.	For Microsemi development use only, leave pins float.
EE0	110	B8	Input/Output	Z/Pull-down	Emulator control pin.	
EE1	111	C8	Input/Output	Z/Pull-down	Emulator debug output pin.	For Microsemi development use only, leave pins float.
UARTTX	94	C11	Output	1	Transmit pin.	
UARTRX	95	C10	Input	Z/Pullup	Receive pin.	

Table 5. Le79128 VCP Device Pin Description (Peripheral Logic Pins)

Pin Name (Alternate)	TQFP Pin #	LBGA Pin #	Type	Reset ¹	Description
SPI1_CLK	58	K10	Output	0	SPI1 clock output.
SPI1_MOSI	54	M10	Input/ Output	Z	SPI1 Master output, Slave input.
SPI1_MISO	52	L10	Input	Z	SPI1 Master input, Slave output.
SPI2_CS	41	K9	Output	1	SPI2 alternate chip select output.
SPI2_CLK	38	K8	Output	0	SPI2 clock output.
SPI2_MOSI	43	M9	Input/ Output	Z	SPI2 Master output, Slave input. If unused, tie to DVSS through 10 KΩ resistor.
SPI2_MISO	45	L9	Input	Z	SPI2 Master input, Slave output. If unused, tie to DVSS through 10 KΩ resistor.
GPIO0 ($\overline{\text{MINT0}}$ /TIMER0)	76	H10	Input/ Output	Z/Pullup	General Purpose I/O. Can function as an Interrupt input when connected to a SLAC device. Also has timer input/output functionality.
GPIO1 ($\overline{\text{MINT1}}$ /TIMER1)	77	G11			
GPIO2 ($\overline{\text{MINT2}}$)	78	G12			
GPIO3 ($\overline{\text{MINT3}}$)	79	F11			
GPIO4 ($\overline{\text{MINT4}}$)	82	F12			
GPIO5 ($\overline{\text{MINT5}}$)	83	E11			
GPIO6 ($\overline{\text{MINT6}}$)	85	D10			
GPIO7 ($\overline{\text{MINT7}}$)	92	D11			
GPIO8 ($\overline{\text{MINT8}}$)	98	B11			
GPIO9 ($\overline{\text{MINT9}}$)	99	A11			
GPIO10 ($\overline{\text{MINT10}}$)	100	B10			
GPIO11 ($\overline{\text{MINT11}}$)	101	A10			
GPIO12 ($\overline{\text{MINT12}}$)	102	C9			
GPIO13 ($\overline{\text{MINT13}}$)	103	B9			
GPIO14 ($\overline{\text{MINT14}}$)	106	A9			
GPIO15 ($\overline{\text{MINT15}}$)	107	A8			General Purpose I/O. Can function as an Interrupt input when connected to a SLAC device.
GPIO16 ($\overline{\text{MCS0}}$)	36	H3	Input/ Output	Z/Pull-down (Note, this pull-down is present only during reset)	General Purpose I/O. Can function as a gated Chip Select for a Serial slave device.
GPIO17 ($\overline{\text{MCS1}}$)	7	C2			
GPIO18 ($\overline{\text{MCS2}}$)	8	D2			
GPIO19 ($\overline{\text{MCS3}}$)	12	E2			
GPIO20 ($\overline{\text{MCS4}}$)	13	F2			
GPIO21 ($\overline{\text{MCS5}}$)	15	G2			
GPIO22 ($\overline{\text{MCS6}}$)	19	E3			
GPIO23 ($\overline{\text{MCS7}}$)	20	F3			
GPIO24 ($\overline{\text{MCS8}}$)	2	A2			
GPIO25 ($\overline{\text{MCS9}}$)	1	B2			
GPIO26 ($\overline{\text{MCS10}}$)	128	A3			
GPIO27 ($\overline{\text{MCS11}}$)	127	B3			
GPIO28 ($\overline{\text{MCS12}}$)	126	D3			
GPIO29 ($\overline{\text{MCS13}}$)	125	C3			
GPIO30 ($\overline{\text{MCS14}}$)	124	C4			
GPIO31 ($\overline{\text{MCS15}}$)	123	C5			General Purpose I/O. Can function as a gated Chip Select for a Serial slave device. These pins serve a dual purpose, they provide boot up options for Microsemi use. Do not use pull-up devices on these nodes. Refer to Table 12 for more information.

Table 5. Le79128 VCP Device Pin Description (Peripheral Logic Pins) (Continued)

Pin Name (Alternate)	TQFP Pin #	LBGA Pin #	Type	Reset ¹	Description
AUXOUT	96	L7	Output	0	General Purpose I/O. Can function as a gated Chip Select for a Serial slave device.

Table 6. Le79128 VCP Device Pin Description (Power Supply Pins)

Pin Name	TQFP Pin #	LBGA Pin #	Type	Description
PLL_VDD	115	A6	Supply	Analog power supply, which must be connected to the digital power supply externally. It is important to provide a decoupling capacitor of 0.1 μ F from PLL_VDD to PLL_VSS.
PLL_VSS	114	B7	Ground	Analog ground. Analog and digital grounds must be connected externally to the same ground plane.
DVDD1	121	G3	Supply	+3.3 V Digital power supply. This supply handles the 3.3 V external digital I/O devices. It is important to provide local decoupling capacitors of 0.1 μ F to the ground plane on each pin in addition to a parallel 10 μ F capacitor on the ground plane.
DVDD2	104	D4		
DVDD3	87	E4		
DVDD4	71	J4		
DVDD5	57	F6		
DVDD6	40	E9		
DVDD7	26	H9		
DVDD8	10	J9		
VDD18_1	17	G4	Supply	+1.8 V Digital power supply. It is important to provide local decoupling capacitors of 0.1 μ F to the ground plane on each pin in addition to a parallel 10 μ F capacitor on the ground plane.
VDD18_2	49	D6		
VDD18_3	80	G6		
VDD18_4	112	J7		
VDD18_5	—	D9		
VDD18_6	—	G10		
DVSS1	122	G1	Ground	Digital ground. Digital and analog grounds must be connected.
DVSS2	105	F4		
DVSS3	89	H4		
DVSS4	72	D5		
DVSS5	56	J5		
DVSS6	39	J6		
DVSS7	24	D7		
DVSS8	9	F7		
DVSS9	88	D8		
DVSS10	25	J8		
DVSS11	—	F9		
DVSS12	—	G9		
VDD18CTRL	113	A7	Output	+1.8 V linear regulator gate drive output. Generally not used, leave pin float.

Table 7. Le79128 VCP Device Pin Description (Control Pins)

Pin Name	TQFP Pin #	LBGA Pin #	Type	Reset ¹	Description
$\overline{\text{RST}}$	21	H1	Input	Z	Active Low reset input returns chip to default state. $\overline{\text{RST}}$ pulse width must be a minimum of 100 ns. If a capacitor to DVSS is used on this pin, as required by some applications, then the minimum $\overline{\text{RST}}$ pulse width is increased to 100 μs . This pin must be externally pulled up.
$\overline{\text{WDT_OUT}}$	18	J1	Output	Z	Active Low, open-drain output from Watchdog timer function. Triggers on watchdog timer expiration and power on reset. The minimum $\overline{\text{WDT_OUT}}$ pulse width for $\overline{\text{WDT_OUT}}$ is 1 ms. This pin must be shorted to $\overline{\text{RST}}$ if the watchdog function is desired to reset the VCP or system.
RSVD	11, 14, 47, 48, 60, 61, 97, 116, 117	A4, A12, B4, B12, E1, F1, L8, M7, M8			Reserved. These pins are internally connected. Pins must be left floating.
NC	16, 93	E5, E6, E7, E8, F5, F8, G5, G7, G8, H5, H6, H7, H8, J10			No connect. These pins are not internally connected. Pins can be used as tie points.

Note:

- Logic state after reset.
 - Z = No state driven, high impedance.
 - 1 = Logic high.
 - 0 = Logic low.
 - Keeper = Kept in current state, not allowed to float.
 - Pull-up = Internal pull-up provided.
 - Pull-down = Internal pull-down provided.
- Used as an input, but pin has I/O capability.
- Used as an output, but pin has I/O capability.

Table 8. Configuration Assignments (CONF₂ - CONF₀)

CONF ₂ - CONF ₀	Host Interface	Parallel Data Width	Parallel Read/Write Strokes
000	Parallel	8	Combined
001	Parallel	8	Separate
010	Parallel	16	Combined
011	Parallel	16	Separate
100	Serial	NA	NA
101	Reserved		
110			
111			

ELECTRICAL CHARACTERISTICS

Absolute Maximum Ratings

Stresses greater than those listed under *Absolute Maximum Ratings* can cause permanent device failure. Functionality at or above these limits is not implied. Exposure to absolute maximum ratings for extended periods can affect device reliability.

Storage Temperature	$-60\text{ }^{\circ}\text{C} \leq T_A \leq +125\text{ }^{\circ}\text{C}$
Ambient Temperature, under Bias	$-40\text{ }^{\circ}\text{C} \leq T_A \leq +85\text{ }^{\circ}\text{C}$
Ambient relative humidity (non condensing)	5 % to 95 %
PLL_VDD with respect to PLL_VSS or DVSS	-0.4 V to +4.0 V
DVDD with respect to PLL_VSS or DVSS	-0.4 V to +4.0 V
VDD18 with respect to DVSS or PLL_VSS	-0.4 V to +1.98 V
Latch up immunity (any pin)	$\pm 100\text{ mA}$
Any other pin with respect to DVSS or PLL_VSS	-0.4 V to (DVDD + 0.4 V)
ESD Immunity (Human Body Model)	JESD22 Class 1C compliant

Package Assembly

The green package devices are assembled with enhanced, environmental compatible lead-free, halogen-free, and antimony-free materials. The leads possess a matte-tin plating which is compatible with conventional board assembly processes or newer lead-free board assembly processes. Refer to IPC/JEDEC J-Std-020 for recommended peak soldering temperature and solder reflow temperature profile.

Operating Ranges

Microsemi guarantees the performance of this device over commercial (0 °C to 70 °C) and industrial (-40 °C to 85 °C) temperature ranges by conducting electrical characterization over each range and by conducting a production test with single insertion coupled to periodic sampling. These characterization and test procedures comply with the Telcordia GR-357-CORE Generic Requirements for Assuring the Reliability of Components Used in Telecommunications Equipment.

Environmental Ranges

Ambient Temperature	-40 °C to +85 °C
Ambient Relative Humidity	15 % to 85 %

Electrical Ranges

DVDD	+3.3 V \pm 5% (see note)
PLL_VDD	+3.3 V \pm 5%, DVDD \pm 50 mV (see note)
VDD18	+1.8 V \pm 5% (see note)
DVSS	0 V
PLL_VSS	DVSS \pm 10 mV
Digital pins with respect to DVSS	DVSS to +3.465 V

Note: +3.3 V supply should ramp and reach a steady final value before +1.8 V supply ramps. \overline{RST} should be held low until both supplies have reached final values. If +3.3 V supply and +1.8 V supply ramps and sequence can not be guaranteed, both \overline{RST} and \overline{TRST} should be held low until both supplies have reached final values. In the case where +3.3 V supply and +1.8 V supply ramps and sequence can not be guaranteed, \overline{TRST} is typically tied low via a 1 K Ω resistor to ground.

DC Specifications

No.	Item	Condition	Min	Typ	Max	Unit	Note
1	Input Low Voltage		-0.5	—	0.8	V	1
2	Input High Voltage		2.0	—	3.6	V	1
3	$\overline{\text{RST}}$ Input Low Voltage		-0.5		0.5	V	
4	$\overline{\text{RST}}$ Input High Voltage		1.1		3.6	V	
5a	Input Leakage Current	0 to DVDD, outputs in high-Z state.	-10	—	+10	μA	3
5b			-100	—	+100	μA	4
6	Input hysteresis		0.15	0.225	0.3	V	2
7	Output Low Voltage	lol = 10 mA	—	—	0.4	V	5
8	Output High Voltage	loh = 400 μA	DVDD -0.4	—	—		5
9	DVDD / PLL_VDD Power Dissipation	DSP in peak operation.	—		50	mW	6
10	VDD18 Power Dissipation	DSP in peak operation.	—		800	mW	6

Notes:

1. Applies to all digital input pins except $\overline{\text{RST}}$.
2. Applies to all digital input pins.
3. Applies to all digital pins with no pull-up, pull-down or keeper.
4. Applies to all digital pins with pull-up, pull-down or keeper.
5. Applies to all digital output pins.
6. No external DC loads present.

HOST BUS INTERFACE (HBI) OVERVIEW

The Host Bus Interface provides a means for exchanging control, configuration, and status information with an external host processor. The HBI is able to sustain 16-bit transactions up to 10 MHz rate with minimal latency.

This interface is implemented through a combination of hardware and firmware. The design is layered as shown in [Figure 3](#). Hardware provides a generic means for transporting data between the host and internal memory. The interpretation of the data is provided by firmware running on the VCP. This layered architecture allows the definition of the application level interface to change by modifying the firmware.

Figure 3. Host Bus Interface Layers

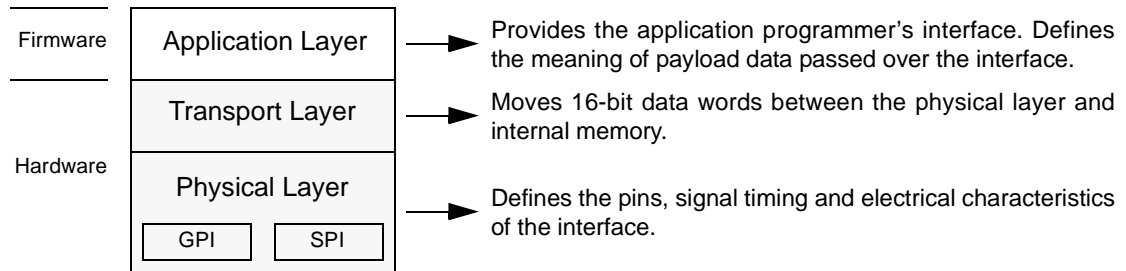

Transport Layer

The transport layer moves 16-bit data words between the physical interface and internal memory or registers on an internal bus. It defines the structure of a transport frame, which consists of a 16-bit command word followed by 0 or more 16-bit payload data words. It also defines the interface address model, and provides mapping between interface and internal addresses.

Application Layer

The application layer defines the programmer's interface, and is almost entirely implemented in firmware. The exception is a handful of configuration registers implemented in hardware. This layer defines the meaning of the payload data delivered by the transport layer. Because it is implemented in firmware, the definition of the programmer's interface can change by providing new software.

Physical Layer

The physical layer provides the functionality needed to electrically interface with a host processor. It defines the pins, signal timing and electrical characteristics of the interface. Two physical interfaces are provided. The General Purpose Parallel Interface (GPI) implements an 8-bit or 16-bit wide parallel interface. Options are selected via the configuration pins, refer to [Table 8](#). The Serial Peripheral Interface (SPI) implements a 4-wire synchronous serial slave interface.

The NG chipset (Le79271 SLIC, Le79238 SLAC, and Le79128 VCP) supports use of the GPI 16-bit interface.

Refer to the *Next Generation Carrier Chipset Hardware Design Guide* for connection diagrams.

TRANSPORT LAYER

The primary responsibility of the transport layer is to move 16-bit data words between the physical interface and the device's internal memory. Data is organized into transport frames, which consist of a 16-bit command word followed by 0 or more data words. The command word provides address and length information to the transport hardware. In a sense, this hardware provides an internal DMA-like function, moving data over the internal bus under host control. Both the GPI and SPI physical layers share a common transport layer.

Interface Addressing

The transport command word provides address information to the interface hardware.

The host interface address model is based on a paged memory scheme as shown in [Figure 4](#). The command design permits up to 257 pages, with up to 128 offset-addressable 16-bit wide register locations. Therefore, an interface address is composed of an 8-bit page number and a 7-bit register offset. Pages are selected by using a command to write the page register. All data access commands operate on the selected page. One exception is the direct page, which can be accessed at any time without changing the page register.

Figure 4. Host Bus Interface Address Model

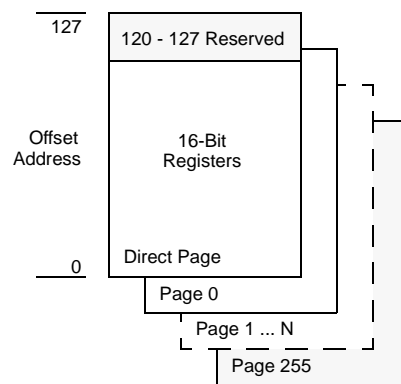

Notes:

1. Page 255 is reserved for loading code.
2. $N = 15$.

Command Structure

All transport frames start with a 16-bit command word followed by 0 or more 16-bit data words. The same command format is used for both the GPI and the SPI. [Table 9](#) provides a list of transport commands followed by a short description of each command.

Table 9. Host Bus Interface Transport Commands

Transport Command	Command Bit Position								Number of 16-bit Data Words
	15	14	13	12	11	10	9	8	
	7	6	5	4	3	2	1	0	
Paged Offset Access	0	Offset Address (0 - 127)							Length + 1
	r/w ^a	Length (0 - 127)							
Direct Offset Access	1	Offset Address ^b (0 - 119)							Length + 1
	r/w ^a	Length ^b (0 - 119)							
Start Paged Access	1	1	1	1	1	0	0	r/w ^a	Length + 1
	Length (0 - 255)								
Continue Paged Access	1	1	1	1	1	0	1	r/w ^a	Length + 1
	Length (0 - 255)								
Configure Interface	1	1	1	1	1	1	0	1	0
	Interface Option Bits								
Select Page	1	1	1	1	1	1	1	0	0
	Page Number (0 - 255)								
NOP	1	1	1	1	1	1	1	1	0
	1	1	1	1	1	1	1	1	

a. Read/Write select bit. 0 = Read. 1 = Write.

b. Addresses 120 - 127 on the Direct Page are reserved.

Paged Offset Access

This command accesses one or more contiguous 16-bit registers on the currently selected page. The 7-bit offset specifies the starting address on the page. The command is followed by (Length + 1) 16-bit data words. The 7-bit Length field allows accessing between 1 and 128 locations with a single transport frame. For nonzero Lengths, the address automatically increments, and consecutive locations are accessed.

Direct Offset Access

Direct Offset Access is the same as Paged Offset Access, except that the direct page is the target. By using this command, the direct page can be accessed at any time without modifying the page register.

Start Paged Access

This command accesses a contiguous stream of 16-bit data words starting from offset 0 on the currently selected page. The command is followed by (Length + 1) 16-bit data words. The 8-bit Length field allows accessing between 1 and 256 locations (i.e. up to 512 bytes) with a single transport frame. Access always begins from offset 0, and the address automatically increments.

Continue Paged Access

Continue Paged Access is the same as the Start Paged Access, except that access starts from where the last paged access left off. By using this command, packets of arbitrary length can be supported. This gives the host the flexibility to split packets transfer into smaller sizes if desired.

Select Page

This command selects the active interface page. It is a write only command and is followed by 0 data words. The 8-bit page field allows up to 256 selectable pages to be defined.

HBI Page Selection (PGSEL)

Command 0xFE (W)

D7	D6	D5	D4	D3	D2	D1	D0
PG_SEL [7:0]							

PG_SEL: Page addressed by any non-direct HBI access.

Configure Interface

This command is used to configure various physical interface options. It is a write-only command and is followed by 0 data words. The Interface Option Bits field allows the following features to be programmed by the host: Wait Pin Polarity (active High or active Low), Wait Pin Enable (default is tri-state), Wait Pin Drive Mode (open-source/open-drain or TTL), Interrupt Pin Drive Mode (open-drain or TTL), and Endian Control (Big or Little). If this register is not programmed correctly, it is possible that the host may not be able to communicate with the VCP device properly. This should be part of the HAL (Hardware Abstraction Layer) function used to initialize the device.

HBI User Interface Pin Configuration (PINCONFIG)

Command 0xFD (W)

D7	D6	D5	D4	D3	D2	D1	D0
RSVD	RSVD	RSVD	INT_DRV	PWAIT_DRV	PWAIT_EN	PWAIT_POL	END_SEL

RSVD: Should be written as 0.

INT_DRV: $\overline{\text{INT}}$ pin drive mode.

0: Open drain (default).
1: TTL.

PWAIT_DRV: PWAIT pin drive mode.

0: CMOS-drive (default). Pin is actively driven to both polarities. When $\overline{\text{PCS}}$ is deasserted (High), the PWAIT pin is driven inactive.
1: Open source or drain depending on polarity. Pin is actively driven to its active polarity as specified by the PWAIT_POL setting. When PCS is deasserted(High), the PWAIT pin is tri-stated.

PWAIT_EN: PWAIT pin enable.

0: Disabled (default).
1: Enabled.

PWAIT_POL: PWAIT pin polarity.

0: Active Low (default).
1: Active High.

END_SEL: Endian select.

0: Big endian (default).
1: Little endian.

Note:

The commands are not affected by endianness; their order must be maintained per documentation. Hence, little-endian systems will need to reverse the command structure.

NOP

A command is reserved to serve as a NOP. Note that all commands except for the Offset Access commands are implemented by reserving an address from the direct page.

VCP Direct Page Hardware Register Summary

[Table 10](#) provides an overview listing of the hardware derived registers. These registers reside on the Direct Page.

Table 10. VoiceEdge™ VCP Hardware Derived Register Space

Register Name	Mnemonic	Register Description	Offset	Notes
Interrupt Indication	INTIND	Used by <code>VpGetEvent ()</code> to get the next event from the queue.	0x00	
Interrupt Parameter	INTPARAM	Used by <code>VpGetEvent ()</code> to get the next event's parameter.	0x01	
Page Offset	PGOFFSET	Allows for interleaved page accesses. Not used by the VP-API.	0x02	
Mailbox Flag	MBFLAG	Used by the VCP firmware and VP-API to provide page handshaking.	0x03	
Page 255 Checksum (High)	CHKSUM	Checksum of Boot Load data.	0x04	
Page 255 Checksum (Low)			0x05	
Page 255 Base Address (High)	BASE_ADDR	Used for Boot Load.	0x06	
Page 255 Base Address (Low)			0x07	
PCLKB Select	PCLKB_SEL	PCLK A and B Select Register: VCP defaults to autodetect the PCLK rate.	0x08	
PCLKA Select	PCLKA_SEL		0x09	
Clock Status	CLKSTAT	System Clock status	0x0A	
MCLK Configuration	MCLKCONFIG	Reference Clock configuration	0x0B	
System Real Time Status	SYSSTAT	System Interrupt (fault) status.	0x0C	
System Interrupt Mask	SYSMASK	System Interrupt (fault) mask.	0x0D	
Boot Sense (High)		Boot sense value. It contains the steady state (pulled up or down) values of each GPIO pin as sensed by the Boot Loader.	0x14	These registers are updated by firmware some time after reset
Boot Sense (Low)			0x15	
Reset Type		A 4-bit value indicating the cause of the last System Reset event.	0x16	
Entry Address (High)	ENT_ADDR	Program entry address for an HBI-loaded application. The host application image will write this register before writing the Software Flags register to launch the application correctly.	0x18	
Entry Address (Low)			0x19	

Direct Page (Hardware) Registers

This section details each of the VoiceEdge VCP device registers provided by the hardware or boot firmware. These registers are provided for debugging purposes only. The VP-API has corresponding definitions for their addresses (and bit definitions) and knows how to read/write these registers.

Note:

In all registers, "RSVD" should be written 0 and reads as indeterminate, unless otherwise indicated.

Interrupt Indication (INTIND)				Direct page address 0x00 (RO)			
D15	D14	D13	D12	D11	D10	D9	D8
D7	D6	D5	D4	D3	D2	D1	D0
INT_SRC	INT_IND[14:8]						
INT_IND[7:0]							

This register reports the source information for the current interrupt. It returns 0x0000 if there is no active interrupt. Reading this register clears the associated interrupt and loads the INTPARAM register with the associated parameter. In most cases the host should read the INTPARAM register after reading this register. This can be accomplished with one multi-word read, since the INTPARAM register immediately follows the INTIND register.

INT_SRC Interrupt source bit.
 0: Event queue.
 1: System interrupt register.

INT_IND[14:0] Interrupt indication field. The contents of this field depend on the interrupt source bit. If the INT_SRC indicates a system interrupt, each subsequent bit indicates a transition on the corresponding system interrupt status register bit (refer to the SYSINTSTAT register for details). Only unmasked system interrupts will appear in this manner. If INT_SRC is 0, an application specific interrupt is present.

Interrupt Parameter (INTPARAM)				Direct page address 0x01 (RO)			
D15	D14	D13	D12	D11	D10	D9	D8
D7	D6	D5	D4	D3	D2	D1	D0
INT_PARAM[15:8]							
INT_PARAM[7:0]							

This register returns the parameter for the last interrupt read from the INTIND register. It is updated whenever the INTIND register is read. Reading this register does not change the state of the interrupt hardware.

INT_PARAM[15:0] Interrupt parameter field. The meaning of this field depends on the associated interrupt. System interrupts will mirror the system interrupt status (SYSINTSTAT) register at the time the INTIND read occurred.

Page Offset (PGOFFSET)**Direct page address 0x02 (RW)**

D15	D14	D13	D12	D11	D10	D9	D8
D7	D6	D5	D4	D3	D2	D1	D0
RSVD						PG_OFFSET[9:8]	
PG_OFFSET[7:0]							

Page Offset contains a pointer to the address of the next transaction into the current mailbox. This register allows interleaved access to a given page. To implement interleaved access, the host must read this register prior to changing the active page. After restoring the active page the host must restore the Page Offset to continue accesses from the previous position with a Continue Page access command. Alternatively, a paged offset access may be used, immediately.

PG_OFFSET[9:0] Address offset of the next access to the currently selected mailbox.

Mailbox Flag (MBFLAG)**Direct page address 0x03 (RW)**

D15	D14	D13	D12	D11	D10	D9	D8
D7	D6	D5	D4	D3	D2	D1	D0
RSVD	RSVD	RSVD	RSVD	RSVD	RSVD	RSVD	RSVD
RSVD	RSVD	RSVD	RSVD	RSVD	RSVD	RSP_FLAG	CMD_FLG

This register indicates access rights to the VCP device's command and response mailboxes corresponding to page 0 and 1 respectively. The VCP device transfers mailbox control to the host by writing a 0 to the respective bit indicating that the host has access to the corresponding mailbox. The host transfers mailbox control to the VCP device by writing a 1 to the bit which corresponds to the mailbox to which the host is relinquishing control. Note that the host and the VCP device can only relinquish control of a mailbox. Neither can request control and it is therefore important that both relinquish control in a reasonably expedient manner.

CMD_FLAG The host sets the Command Mailbox flag by writing a 1 to the associated bit. Writing a 0 to any bit has no affect.

- 0: Host owns associated mailbox.
- 1: DSP owns associated mailbox.

RSP_FLAG The host sets the Response Mailbox flag by writing a 1 to the associated bit. Writing a 0 to any bit has no affect.

- 0: Host owns associated mailbox.
- 1: DSP owns associated mailbox.

Page 255 Checksum High Register**Direct page address 0x04 (RW)**

D15	D14	D13	D12	D11	D10	D9	D8
D7	D6	D5	D4	D3	D2	D1	D0
CHKSUM[31:24]							
CHKSUM[23:16]							

Page 255 Checksum Low Register**Direct page address 0x05 (RW)**

D15	D14	D13	D12	D11	D10	D9	D8
D7	D6	D5	D4	D3	D2	D1	D0
CHKSUM[15:8]							
CHKSUM[7:0]							

This double-word register holds the checksum for any boot operation. The code load integrity is guaranteed by the checksum hardware which resides in this register. This register is used by the VP-API to verify the integrity of a boot load operation.

Page 255 Base Address High Register (BASE255)**Direct page address 0x06 (RW)**

D15	D14	D13	D12	D11	D10	D9	D8
D7	D6	D5	D4	D3	D2	D1	D0
RSVD	RSVD	BASE_ADDR[29:24]					
BASE_ADDR[23:16]							

Page 255 Base Address Low Register (BASE255)**Direct page address 0x07 (RW)**

D15	D14	D13	D12	D11	D10	D9	D8
D7	D6	D5	D4	D3	D2	D1	D0
BASE_ADDR[15:8]							
RSVD							RESET

This double-word register is used for code loading. The API uses this register accordingly. The host software needs no further manipulation of this register.

BASE_ADDR[31:8] Upper address bits of Page 255 accesses.

RESET: (Read only) This bit can be polled to indicate when the internal chip reset is complete.

Note: This Page 255 Base Low Register can be polled immediately after \overline{RST} is deasserted high or power is applied to determine when internal chip reset is complete. No other register should be read or written during this time. This register will return 0xFF01 until reset is complete at which time 0xFF00 is returned.

PCLKB Select (PCLKB_SEL)**Direct page address 0x08 (RW)**

D15	D14	D13	D12	D11	D10	D9	D8
D7	D6	D5	D4	D3	D2	D1	D0
AUTO-DETECTB	AUTO-HIWAYBA	FSB_GEN	PCLKB_FREQ[12:8]				
PCLKB_FREQ[7:0]							

PCLKB_SEL is used to configure the PCLKB input to the VCP, depending on the relationship between FSB (frame sync) and PCLKB.

AUTODETECTB Auto-detected Redundant Highway.

0: Autodetect disabled. PCLKB_FREQ[12:0] should be set by the user.

1: Autodetect the frequency of PCLKB based on the FSB period and store result in PCLKB_FREQ[12:0]. When high the auto detection is restarted and the

PCLKB_FREQ field is initialized (default)

AUTO_HIWAYBA	Redundant Highway to Highway A Switch. 0: Disable highway automatic switching option. 1: Automatically switch from Redundant Highway to Highway A if CFAIL_PCLKB=1 and CFAIL_PCLKA=0 (See CLKGEN_STATUS for definition of CFAIL_PCLK)
FSB_GEN	FSB Generation. 0: FSB is provided externally. 1: FSB is generated by the VCP device at the specified frequency. Whenever this bit is set to High, the AUTODETECTB bit should be set to low by the host software.
PCLKB_FREQ[12:0]:	Indicates the set frequency of PCLKB as a multiple of 8KHz -1. When writing AUTODETECTB = 1, the default is restored to these bits 1001011111011 until the auto-detection is complete. PCLKB can be any frequency that is a multiple of 512KHz +/- 6000ppm. The software supports PCLK frequencies up to 8.192 MHz. 0000000111111: PCLKB = 512 kHz. 0000010111111: PCLKB = 1.536 MHz 0000011111111: PCLKB = 2.048 MHz. 0000111111111: PCLKB = 4.096 MHz. 0001111111111: PCLKB = 8.192 MHz. 0011111111111: PCLKB = 16.384 MHz. 1000100111111: PCLKB = 35.328 MHz ADSL clock 1001011111011: PCLKB = 38.880 MHz (default)

Using FSB as an 8-kHz reference, the device will automatically select the correct PCLKB_FREQ value. The initial PCLKB_FREQ[12:0] setting will be 1001011111011 (PCLKB=38.880 MHz). If the FSB or PCLKB pulses are absent, the device will maintain CSEL[12:0] = 1001011111011 until it detects transitions on both the FSB and PCLKB inputs. Automatic frequency detection will occur after 9 consistent FSB periods. Meaning, reading this register before the mentioned 1.125 ms will report the default (0x92FB) PCLKB, not the actual PCLKB frequency.

If FSB is to be generated internally, set FSB_GEN bit to internal generation, set the AUTODETECTB bit to 0 and write the appropriate clock frequency register PCLKB_FREQ[12:0] with the desired value. This can be done in the Hardware Abstraction Layer (HAL) function used to initialize the chip and configure the HBI interface. This should be done before booting the device.

PCLKA Select (PCLKA_SEL)

Direct page address 0x09 (RW)

D15	D14	D13	D12	D11	D10	D9	D8	
D7	D6	D5	D4	D3	D2	D1	D0	
AUTO-DETECTA	AUTO_HIWAYAB	FSA_GEN	PCLKA_FREQ[12:8]					
PCLKA_FREQ[7:0]								

PCLKA_SEL is used to configure the PCLKA input to the VCP, depending on the relationship between FSA (frame sync) and PCLKA.

AUTODETECTA	Highway A Auto Detect. 0: Autodetect disabled. PCLKA_FREQ[12:0] should be set by the user. 1: Autodetect the frequency of PCLKA based on the FSA period and store result in PCLKA_FREQ[12:0]. When High, the auto detection is restarted and the PCLKA_FREQ field is initialized (default).
-------------	---------------------------------------------------------------------------------------------------------------------------------------------------------------------------------------------------------------------------------------------------------------------------------------------------

AUTO_HIWAYAB	Highway A to Redundant Highway Switch. 0: Disable highway automatic switching option. 1: Automatically switch from Highway A to Redundant Highway if CFAIL_PCLKA=1 and CFAIL_PCLKB=0 (See CLKGEN_STATUS for definition of CFAIL_PCLK)																
FSA_GEN	FSA Generation. 0: FSA is provided externally. 1: FSA is generated by the VCP device at the specified frequency. When ever this bit is set to High. the AUTODETECTA bit should be set to Low.																
PCLKA_FREQ[12:0]:	Indicates the set frequency of PCLKA as a multiple of 8KHz -1. When writing AUTODETECTA = 1, the default is restored to these bits 1001011111011 until the auto-detection is complete. PCLKA can be any frequency that is a multiple of 512KHz +/- 6000ppm. The software supports PCLK frequencies up to 8.192 MHz. <table border="0"> <tr><td>0000000111111:</td><td>PCLKA = 512 kHz.</td></tr> <tr><td>0000010111111:</td><td>PCLKA = 1.536 MHz</td></tr> <tr><td>0000011111111:</td><td>PCLKA = 2.048 MHz.</td></tr> <tr><td>0000111111111:</td><td>PCLKA = 4.096 MHz.</td></tr> <tr><td>0001111111111:</td><td>PCLKA = 8.192 MHz.</td></tr> <tr><td>0011111111111:</td><td>PCLKA = 16.384 MHz.</td></tr> <tr><td>1000100111111:</td><td>PCLKA = 35.328 MHz ADSL clock</td></tr> <tr><td>1001011111011:</td><td>PCLKA = 38.880 MHz (default)</td></tr> </table>	0000000111111:	PCLKA = 512 kHz.	0000010111111:	PCLKA = 1.536 MHz	0000011111111:	PCLKA = 2.048 MHz.	0000111111111:	PCLKA = 4.096 MHz.	0001111111111:	PCLKA = 8.192 MHz.	0011111111111:	PCLKA = 16.384 MHz.	1000100111111:	PCLKA = 35.328 MHz ADSL clock	1001011111011:	PCLKA = 38.880 MHz (default)
0000000111111:	PCLKA = 512 kHz.																
0000010111111:	PCLKA = 1.536 MHz																
0000011111111:	PCLKA = 2.048 MHz.																
0000111111111:	PCLKA = 4.096 MHz.																
0001111111111:	PCLKA = 8.192 MHz.																
0011111111111:	PCLKA = 16.384 MHz.																
1000100111111:	PCLKA = 35.328 MHz ADSL clock																
1001011111011:	PCLKA = 38.880 MHz (default)																

Using FSA as an 8-kHz reference, the device will automatically select the correct PCLKA_FREQ value. The initial PCLKA_FREQ[12:0] setting will be 1001011111011 (PCLKA=38.880 MHz). If the FSA or PCLKA pulses are absent, the device will maintain CSEL[12:0] = 1001011111011 until it detects transitions on both the FSA and PCLKA inputs. Automatic frequency detection will occur after 9 consistent FSA periods. Meaning, reading this register before the mentioned 1.125ms will report the default (0x92FB) PCLKA, not the actual PCLKA frequency.

If FSA is to be generated internally, set FSA_GEN bit to internal generation, set the AUTODETECTA bit to 0 and write the appropriate clock frequency register PCLKA_FREQ[12:0] with the desired value. This can be done in the Hardware Abstraction Layer (HAL) function used to initialize the chip and configure the HBI interface. This should be done before booting the device.

Clock Status (CLKSTAT)**Direct page address 0x0A (R/W)**

D15	D14	D13	D12	D11	D10	D9	D8
D7	D6	D5	D4	D3	D2	D1	D0
RSVD					CFAIL GLOBAL	CFAIL PCLKB	CFAIL PCLKA
RSVD				POR	RST	WDT	HWRES

CFAIL_GLOBAL:(RO) PLL failure indicator.

- 0: No Failure
- 1: PLL failure detected

CFAIL_PCLKA:(RO) PCLKA clock failure indicator.

- 0: No Failure
- 1: Clock failure detected

CFAIL_PCLKB:(RO) PCLKB clock failure indicator.

- 0: No Failure

1: Clock failure detected

POR:(R/W)	Power up reset indication. This bit is set by a POR event. It can be cleared by writing 0 to it. This bit is cleared by firmware during the boot sequence so that subsequent POR events can be detected. See Table 11.
RST:(R/W)	$\overline{\text{RST}}$ reset indication. This bit is cleared by a POR event and set by the $\overline{\text{RST}}$ pin. It can be written by firmware. The $\overline{\text{RST}}$ bit is cleared by firmware during the boot sequence so that subsequent $\overline{\text{RST}}$ events can be detected. See Table 11.
WDT (R/W)	WDT_ $\overline{\text{OUT}}$ reset indication. This bit is cleared by a POR event and set by the (!RST_N &&!WDT_OUT_N) asserted. The WDT bit is cleared by firmware during the boot sequence so that subsequent WDT events can be detected. See Table 11.
HWRES:(R/W)	Hardware reset. Setting this bit causes a full system reset to occur immediately. After the reset sequence, this bit will still hold the last written value. See Table 11.

Table 11. CLKGEN Status Hardware Reset Controls

POR	RST	WDT	HW_RESET	Notes
x	x	x	0	Hardware induced reset. Follow pin strap options.
0	0	0	1	Host induced reset. Evaluate pin straps and perform full system startup sequence.
0	0	1	1	Reserved
0	1	0	1	Host induced reset. Start previously loaded application without MBIST or Code Loading.
0	1	1	1	Host induced reset. Reserved.
1	x	x	1	

Note: CLKSTAT should only be written to cause a hardware reset. Any other write is illegal.

MCLK Configuration (MCLKCONFIG)**Direct page address 0x0B (R/W)**

D15	D14	D13	D12	D11	D10	D9	D8
D7	D6	D5	D4	D3	D2	D1	D0
RSVD		CURRENT_HIWAY	REFCLK_FREQ[12:8]				
REFCLK_FREQ[7:0]							

CURRENT_HIWAY:(R/W) Currently active PCM highway. This bit is writable but may be modified by hardware if either AUTO_HIWAY bit (*in PCLKA_SEL, address 0x09*) is asserted and a clock failure is present on the appropriate PCLK/FS pair.

0: Highway A. (Default)
1: Redundant Highway.

REFCLK_FREQ:(RO) Indicates the frequency of the selected PLL source clock. The field is read only and the frequency should be programmed in the appropriate PCLKx_SEL register (x =A or B). The frequency is specified as a: (multiple of 8000) - 1.

Note: The power-up default for the 16-bit portion of this register is 0x12FB.

System Real Time Status (SYSSTAT)

Direct page address 0x0C (RO)

D15	D14	D13	D12	D11	D10	D9	D8
D7	D6	D5	D4	D3	D2	D1	D0
1	EV_OV	WDT	CFAIL_ GLOBAL	CFAIL_ PCLKA	CFAIL_ PCLKB	SYS_FLAG[9:8]	
SYS_FLAG[7:0]							

This read only register allows the host to determine the present status of the system faults. It differs from the INTPARAM register in that no interrupt is required to determine the system fault status.

EV_OV Event queue overflow detected. This bit indicates that an event was lost due to event queue overflow. If events are being serviced and generated at the same time it is possible that this flag will be set multiple times. This bit must be cleared by reading INTIND, if the bit is unmasked, or by reading SYSSTAT if it is masked.

WDT Watchdog timer timeout occurred. (default =0) This bit is asserted when the WDT_OUT pin is driven low if a system reset is not induced by that action. This bit must be cleared by reading INTIND, if the bit is unmasked, or by reading SYSSTAT if it is masked.

CFAIL_GLOBAL PLL or selected source Clock Fail status. (default =1)

CFAIL_PCLKA PCLKA/FSA Clock Fail status. (default =1)

CFAIL_PCLKB PCLKB/FSB Clock Fail status. (default =1)

SYS_FLAG[9:0] Software configurable system interrupt real time status bit.

0: The status of the bit is not set (default).

1: When asserted, each bit masks the interrupt caused by a transition on the respective SYS_FLAG bit of the SYSSTAT register. The application software will define the meaning of these bits as needed.

System Interrupt Mask (SYSMASK)

Direct page address 0x0D (RW)

D15	D14	D13	D12	D11	D10	D9	D8
D7	D6	D5	D4	D3	D2	D1	D0
EVENT_ DELAY	MOVL	MWDT	MCFAIL_ GLOBAL	MCFAIL_ PCLKA	MCFAIL_ PCLKB	MSYS_FLAG[9:8]	
MSYS_FLAG[7:0]							

This register is used to mask system interrupt sources. There is a one to one correspondence between the bit definitions in SYSMASK and INTIND when INTIND represents a system interrupt.

EVENT_DELAY: Event delay bit

0: Low priority event queue (two, three) interrupts are reported to the host by asserting the $\overline{\text{INT}}$ pin whenever an event is present in those queues. (default)
1: Low priority event queue (two, three) interrupts cannot pull the $\overline{\text{INT}}$ pin low or output events unless a system interrupt or high priority event queue one interrupt was first present to assert the $\overline{\text{INT}}$ pin. This feature allows fewer host interruption from the lower priority events.

MOVL: Interrupt Queue Overflow mask. When asserted the interrupt is masked.

(Default = 1). If this bit is asserted (masked), the SYSSTAT must be read to clear the OVL status. Otherwise, if the OVL is unmasked, a read of the INTIND clears the OVL status bit.

MWDT: Watch Dog Timer mask. When asserted the interrupt is masked (default = 1). If this bit is asserted (masked), the SYSSTAT must be read to clear the WDT status. Otherwise, if the WDT is unmasked, a read of INTIND clears the WDT status bit.

MCFAIL GLOBAL:PLL or selected source Clock Fail mask. When asserted the interrupt is masked. (default = 1)

MCFAIL PCLKA: PCLKA/FSA Clock Fail mask. When asserted the interrupt is masked. (default = 1)

MCFAIL PCLKB: PCLKB/FSB Clock Fail mask. When asserted the interrupt is masked. (default = 1)

MSYS_FLAG[9:0]: Software configurable system interrupt mask bit. When asserted the interrupt is masked. (default = 1)

Boot Sense [GPIO31:16]**Direct page address 0x14 (RW)**

D15	D14	D13	D12	D11	D10	D9	D8
D7	D6	D5	D4	D3	D2	D1	D0
GPIO[31]	GPIO[30]	GPIO[29]	GPIO[28]	GPIO[27]	GPIO[26]	GPIO[25]	GPIO[24]
GPIO[23]	GPIO[22]	GPIO[21]	GPIO[20]	GPIO[19]	GPIO[18]	GPIO[17]	GPIO[16]

GPIO[31:16]: Reset GPIO input value.

Boot Sense [GPIO15:0]**Direct page address 0x15 (RW)**

D15	D14	D13	D12	D11	D10	D9	D8
D7	D6	D5	D4	D3	D2	D1	D0
GPIO[15]	GPIO[14]	GPIO[13]	GPIO[12]	GPIO[11]	GPIO[10]	GPIO[9]	GPIO[8]
GPIO[7]	GPIO[6]	GPIO[5]	GPIO[4]	GPIO[3]	GPIO[2]	GPIO[1]	GPIO[0]

GPIO[15:0]: Reset GPIO input value.

Reset Type**Direct page address 0x16 (R)**

D15	D14	D13	D12	D11	D10	D9	D8
D7	D6	D5	D4	D3	D2	D1	D0
RSVD							
RSVD				POR	RST	WDT	HWRES

A four-bit value indicating the cause of the last System Reset event. The Boot Loader copies CLKSTAT [19:16] into the low nibble of this register. See Table 12 for interpretation of these bits.

Entry Address High Register**Direct page address 0x18 (RW)**

D15	D14	D13	D12	D11	D10	D9	D8
D7	D6	D5	D4	D3	D2	D1	D0
ENT_ADDR [31:24]							
ENT_ADDR [23:16]							

Entry Address Low Register**Direct page address 0x19 (RW)**

D15	D14	D13	D12	D11	D10	D9	D8
D7	D6	D5	D4	D3	D2	D1	D0
ENT_ADDR [15:8]							
ENT_ADDR [7:0]							

Program entry address for an HBI-loaded application. The host application image will write this double-word register before writing the Software Flags register to launch the application correctly.

Code Loading

The VCP device will always come up in Boot mode following a power-on reset or when the reset pin of the chip is deasserted. The DSP will delay program execution until the boot sequence is completed as defined by the pin strapping. The VCP device contains an on-chip ROM with initial startup code, a simple ROM monitor, and a boot loader. Before the ROM monitor runs, initial startup code is run to perform system diagnostics. The diagnostics consist of evaluating the GPIO[31:24] boot strap pins, testing for a stable system clock and testing/repairing the device's internal RAM if so configured. The evaluation of the GPIO[31:24] is accomplished by a crude software delay of at least 200 μ s, and then polling the state of those pins. The clock failure may take significant time to disappear due to waiting for autodetection or a host write.

Table 12. Boot Sense Pin Definitions

Pin	Boot Sense Function	Description
GPIO[31]/MCS15	SLOW_SPEED	0: Write the PLL to the maximum frequency(140MHz). 1: Do not adjust the PLLDIV field(98.304MHz).
GPIO[30]/MCS14	CFAIL_SKIP	0: Wait for CFAIL before proceeding with BOOT routine. 1: Do not wait for CFAIL before proceeding.
GPIO[29]/MCS13	BIST_DISABLE	0: Enable Memory BIST/Repair in BOOT routine. 1: Disable Memory BIST/Repair in BOOT routine.
GPIO[28]/MCS12	BOOT_DEBUG	0: Do not enter debug mode. 1: Enter debug mode after Memory BIST if enabled.
GPIO[27]/MCS11	UART_ENABLE	0: Disable UART CLI during booting. 1: Enable UART CLI during booting.
GPIO[26]/MCS10	GPIO_MESSAGES	0: Disable GPIO messages during booting. 1: Enable GPIO messages during booting.
GPIO[25]/MCS9	RSVD	
GPIO[24]/MCS8	RSVD	

Host Boot Procedure

The download code will be composed of a sequence of words that must be presented to the device via the GPI/SPI. These images can be broken up at 128-byte boundaries if needed. The first byte of the sequence (or after a break in the sequence of 128 blocks) must have the PADDR signal asserted. Any Microsemi provided image will conclude with the Page 255 Checksum register returning the value AA55 AA55. This register should be verified by the Host before proceeding.

APPLICATION LAYER

The application layer defines the programmer's interface and is almost entirely implemented in firmware. The exception is a handful of configuration registers implemented in hardware. This layer defines the meaning of the payload data delivered by the transport layer. Because it is implemented in firmware, the definition of the programmer's interface can change by providing new software. The primary elements of the model are system registers, mailbox buffers and an event queue. The following sections describe these elements in more detail.

Software (Application Derived) Registers

The remainder of the registers defined in the HBI register space are application defined registers. For detailed information on these registers, refer to the *VoicePath API II Reference Guide for VCP Devices*.

Mailboxes Buffers

Mailbox buffers are composed of a dedicated interface page and an associated hardware semaphore flag to control ownership. Mailbox buffers pass information in one direction only. The host writes to a downstream mailbox and reads from an upstream mailbox. The reverse is true for the DSP. The flag indicates mailbox status and guards against race conditions.

All mailbox flags are located in the 16-bit software flag register implemented on the direct page. They exhibit the following characteristics. Only the host can set a mailbox flag. Likewise, only the DSP can clear a mailbox flag. High-to-low transitions generate a maskable interrupt towards the host. Low-to-high transitions generate a maskable interrupt towards the DSP.

The following steps illustrate how a mailbox is used to pass information in the downstream (i.e. host-to-DSP) direction. For an upstream exchange, roles are simply reversed.

1. The host waits for the appropriate mailbox flag to go low, indicating that the mailbox is now empty. To do this, the host can either poll the mailbox flag register, or unmask the associated interrupt and wait for an interrupt to be generated.
2. The host selects the mailbox by issuing a Select Page command.
3. The host writes data into the mailbox using either the Paged Offset or Paged Access commands. Data can be written with one command or with several. The first location of the mailbox is used to indicate the length of the data being passed to the DSP. The host is responsible for writing this length value.
4. When the host is finished writing data to the mailbox, it then sets the associated mailbox flag by writing a one to the appropriate bit in the mailbox flag register. This indicates to the DSP that data is waiting in the mailbox, and ownership has passed to the DSP.
5. The DSP either polls the mailbox flag register, or receives an interrupt indicating data is available.
6. The DSP reads and processes the contents of the mailbox taking any required actions. It reads the first location in the mailbox to determine the length of the data.
7. The DSP clears the associated mailbox flag, indicating to the host that it is finished processing and passing ownership back to the host.

Command/Response Mailboxes

This mailbox pair provides a channel for exchanging command and status messages with the host. Refer to the VP-API code for commands. The command mailbox is for the host to write commands. The response mailbox is for the DSP to report the results of read commands or confirmation of write commands.

Event Queue

A key element of the host interface is an event queue. Events relay asynchronous information back to the host. Buffering events in a queue gives the host flexibility on when to read them, and ensures that no events are lost if the host is unable to service them immediately.

The host reads the event queue through the interrupt indication and parameter registers. Events are composed of a 16-bit indication value that includes channel and event type fields, and an optional 16-bit parameter. Several of the Le79128 VCP events require a 32-bit timestamp. The timestamp can be reduced to 16-bits by creating a timestamp rollover event, and letting the host maintain the upper 16-bits. An event reports the lower 16-bits of the timestamp in the parameter register. (See the *VP-API II User's Guide* for information on an event associated with a timestamp).

PHYSICAL LAYER

The physical layer provides both parallel and synchronous serial interfaces. These are described in the following sections.

General Purpose Parallel Interface (GPI)

The General Purpose Parallel Interface (GPI) is an external interface of the VCP device that is used to communicate command information and data to/from an external host processor. The GPI has several configuration options and has been architected to connect gluelessly to a variety of external processors. Options are selected via the configuration pins, refer to [Table 8](#). The GPI interface uses a combination of write, read, data, address, and wait strobes; thus, a dedicated clock is not needed to synchronize the transfers. The structure of the commands and data both take the form of a command word followed by data in order to preserve the same logical view as the Serial Peripheral Interface (SPI). This allows the host to issue the same commands to a VCP device regardless of the physical interface.

GPI External Pin List

The pins related to the GPI are described below. Pins associated with clocks, reset, or interrupts are described in another section

Table 13. GPI Pins

Pin Name	Type	Reset	Description
PCS	Input		GPI Chip Select (active Low)
PADDR	Input		GPI Address Pin (Command or Data Indicator)
PWAIT	Output/Z	Z	GPI Wait (Programmable polarity and drive mode, external pull-inactive required)
PD[15:0] (PD[7:0])	Input/Output/ Z	Z	GPI Data Bus. Alternate configuration as 8-bit Data Bus.
$\overline{\text{PWR}}$ (PDS)	Input		GPI Write Strobe (active Low). Alternate configuration as GPI Data Strobe (active Low)
$\overline{\text{PRD}}$ ($\overline{\text{PRD}}/\overline{\text{WR}}$)	Input		GPI Read Strobe (active Low). Alternate configuration as GPI Read/Write Strobe (Read=High, Write=Low)

Note:

Z = No state driven, high impedance.

GPI Features

The GPI has been designed to connect to a variety of external host processors. The capabilities of the GPI are enumerated below.

1. Commands and data can be transferred across the parallel interface using either separate read and write strobes or using a combined read/write strobe and a data strobe.
2. The GPI can be configured for either 8-bit or 16-bit data bus transfers.
3. A wait strobe can be used to indicate to the external processor that the interface is available for a transfer. When the wait strobe goes active, the interface is busy. The transfer will complete after the wait signal deasserts. The wait strobe pin polarity is programmable and defaults to tri-state. Note: an external pull-up or pull-down (depending on the programmed active state) is required.
4. Data byte swap allows the GPI to support big and little endian systems. (Note that the command is always evaluated as big endian, so little endian systems should byte swap the command word accordingly).
5. A read status register is available to the external processor by performing a read while the address pin is High. The contents of this register contains a wait status indication, which can be used by external processors that do not support the wait pin.

Parallel Interface Status (GPISTATUS)

(RO)

D15	D14	D13	D12	D11	D10	D9	D8
D7	D6	D5	D4	D3	D2	D1	D0
PAGENUM							
RSVD	RSVD	RSVD	RSVD	RSVD	CMD_PROG	INT	PWAIT

Read GPISTATUS with PADDR High.

PAGENUM: Current active page

CMDPROG:	Command in progress.
INT:	$\overline{\text{INT}}$ logic state.
PWAIT:	PWAIT logic state.

6. The address pin is used as a command word demarcation. The command interface is reset during a write operation when the address pin is High. (Note that the command interface is not reset during a read operation when the address pin is High.) This ensures that the command and data sequences between the external processor and the VCP device will be interpreted properly. If a previous command has completed, the next word will be interpreted as a command regardless of PADDR. Refer to [Table 14](#) for a list of the GPI access modes.

Table 14. GPI Interface Access Types

Address	Read or Write	Access Type
0	0	write data
0	1	read data
1	0	write command
1	1	read status

GPI Connections to an External Host

The external interface connection diagrams for two different GPI configurations is shown in [Figure 5](#) and [Figure 6](#).

Figure 5. GPI Connections Using Separate Read and Write Strobes

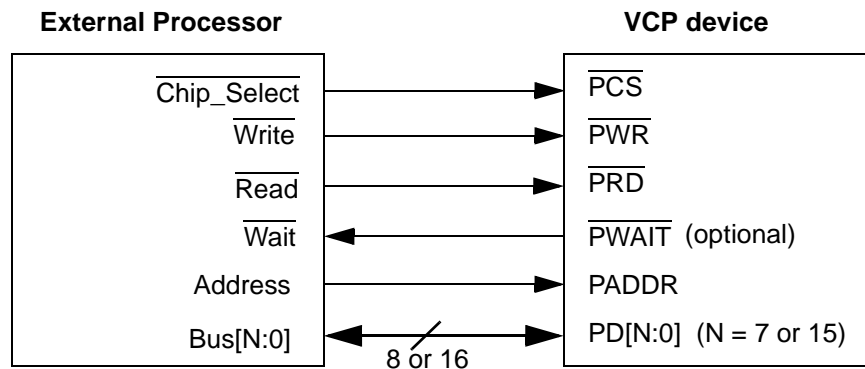
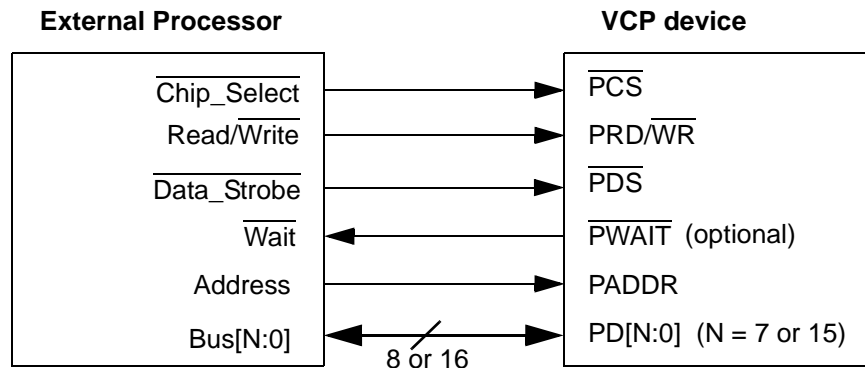

Figure 6. GPI Connections Using Combined Read/Write and Data Strobes



GPI Timing Requirements

The timing requirements for read and write accesses are shown in the following timing diagrams. The PWAIT waveform on the read diagrams is shown as a dotted line because the wait strobe feature is optional and would only go active if the read data was not yet valid following a read command. Also, although the wait strobe polarity is programmable, it is shown as active Low in several of the timing diagrams. Each write and read access is qualified by an active chip select signal. In some applications, the chip select pin could be tied Low. The 16-bit accesses using separate read and write strobes is shown in [Figure 7](#) and [Figure 8](#). The 8-bit accesses using separate read and write strobes are shown in [Figure 9](#) and [Figure 10](#). The timing information for the 8 and 16-bit figures using separate read and write strobes can be found in [Table 15](#). The 8-bit accesses using a combined read/write strobe and a data strobe is shown in [Figure 11](#) and [Figure 12](#). The timing information for the 8 and 16-bit figures using a combined read/write strobe and a data strobe can be found in [Table 16](#). Refer to [Figure 13](#) for an example of the read status register access (which applies to both 8 and 16-bit modes). It should be noted that if the host is using the wait strobe feature and issues a read command, that performing a status read operation immediately after the writing of a read command and before the actual read of the first byte/word of data would cause the read status access to be extended. Refer to [Figure 14](#) for an example of the byte swap operation on the data word (which also applies to 8 and 16-bit modes).

Table 15. GPI Bus Timing Parameters for Separate Read and Write Strobes¹.

No.	Symbol	Parameter	Min	Typ	Max	Unit	Note
1	t_{ACC}	Access period (from Write to Write or Read to Read or Read to Write)	100	—	—	ns	
2	t_{ON}	Pulse width LOW (\overline{PCS} or \overline{PWR} or \overline{PRD})	35	—	—		
3	t_{OFF}	Pulse width HIGH (\overline{PCS} & \overline{PWR} or \overline{PCS} & \overline{PRD})	10	—	—		
4	t_{WR_RDV}	Write to Read (rising \overline{PWR} to Data output valid)	25	—	270		3,4
5	t_{RD_DV}	\overline{PCS} , PADDR, \overline{PRD} active to Data output valid	—	—	25		3
6	t_{SU_IN}	Address, Data input setup time to rising \overline{PCS} or \overline{PWR}	15	—	—		
7	t_{HOLD_IN}	Address, Data input hold time after rising \overline{PWR} or \overline{PCS}	0	—	—		
8	t_{HOLD_OUT}	Data output hold time after rising \overline{PRD} or \overline{PCS}	0	—	10		3
9	t_{CS_WAIT}	Chip Select active to Wait active	—	—	25		2,3
10	t_{WAIT}	Wait strobe width LOW when \overline{PCS} is active	0	80	280		2,3
11	t_{WAIT_DV}	PWAIT deserted to Data valid	—	—	0		2

Notes:

1. Refer to [Figure 26](#) for timing diagram test points.
2. The Wait Strobe active edge may occur as early as the rising Write Strobe signal if Chip Select is held active.
3. The pin load is assumed to be $C_{load} = 75pF$.
4. This is the time between the read command and the first data word. If PWAIT is not used, then the maximum value must be met by the host. If PWAIT is used, faster transactions can occur.

Figure 7. GPI 16-Bit Write Access Using Separate Read and Write Strobes

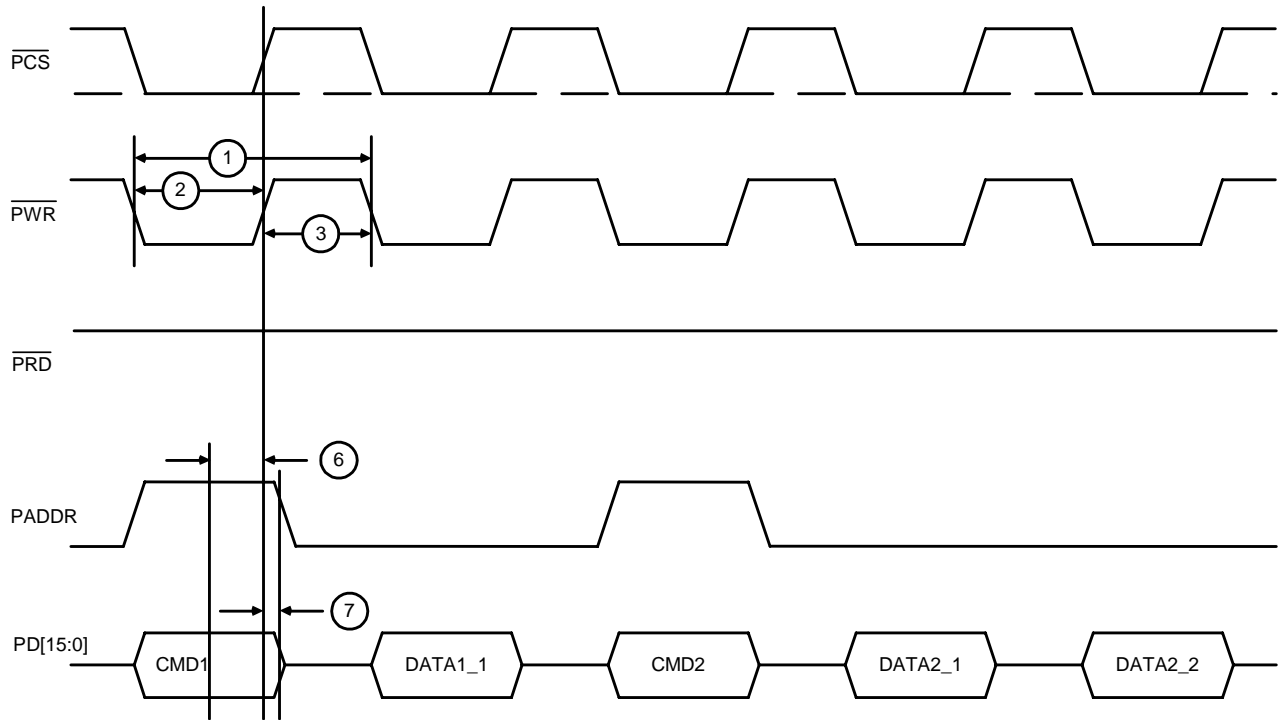

Note: Each Write and Read access is qualified by an active chip select strobe. (Chip select can be tied Low in some applications.)

Figure 8. GPI 16-Bit Read Access Using Separate Read and Write Strobes

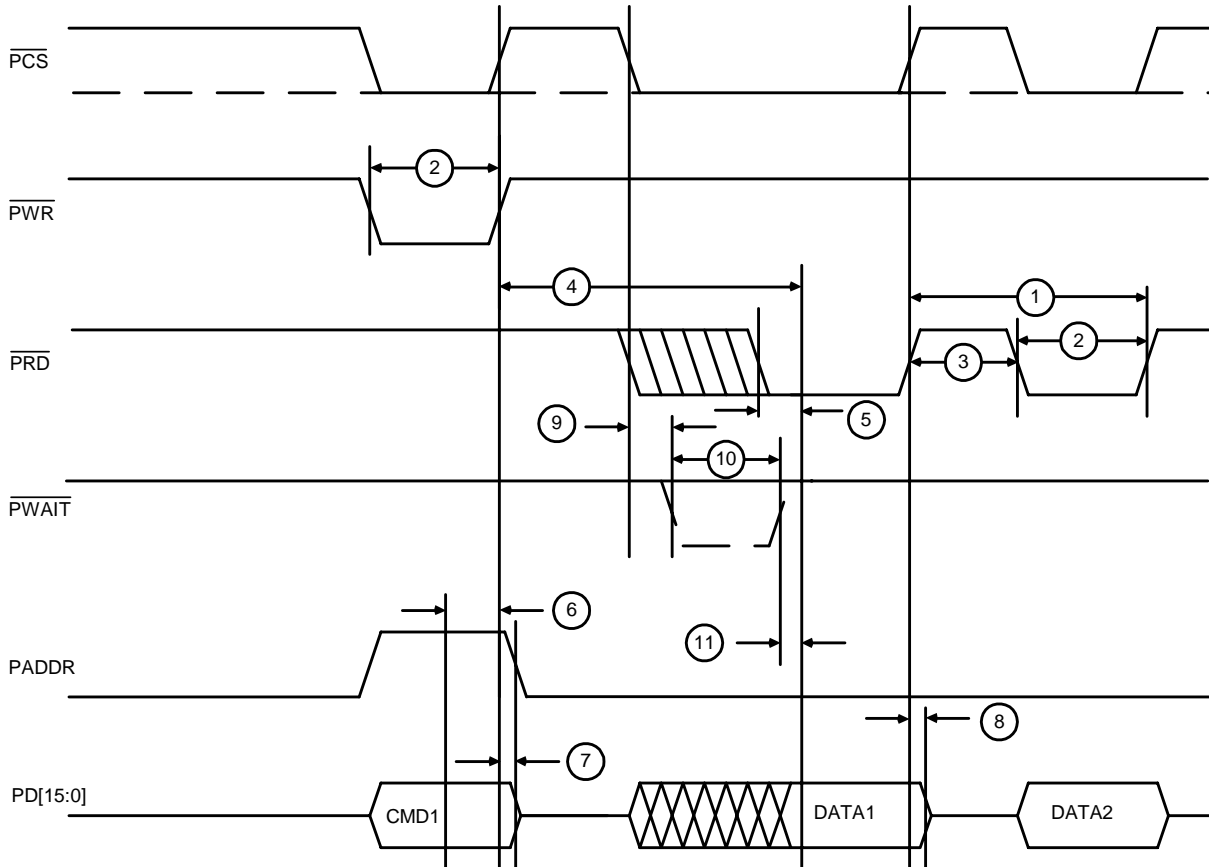

Note: Each Write and Read access is qualified by an active chip select strobe. (Chip select can be tied Low in some applications.)

Figure 9. GPI 8-Bit Write Access Using Separate Read and Write Strobes

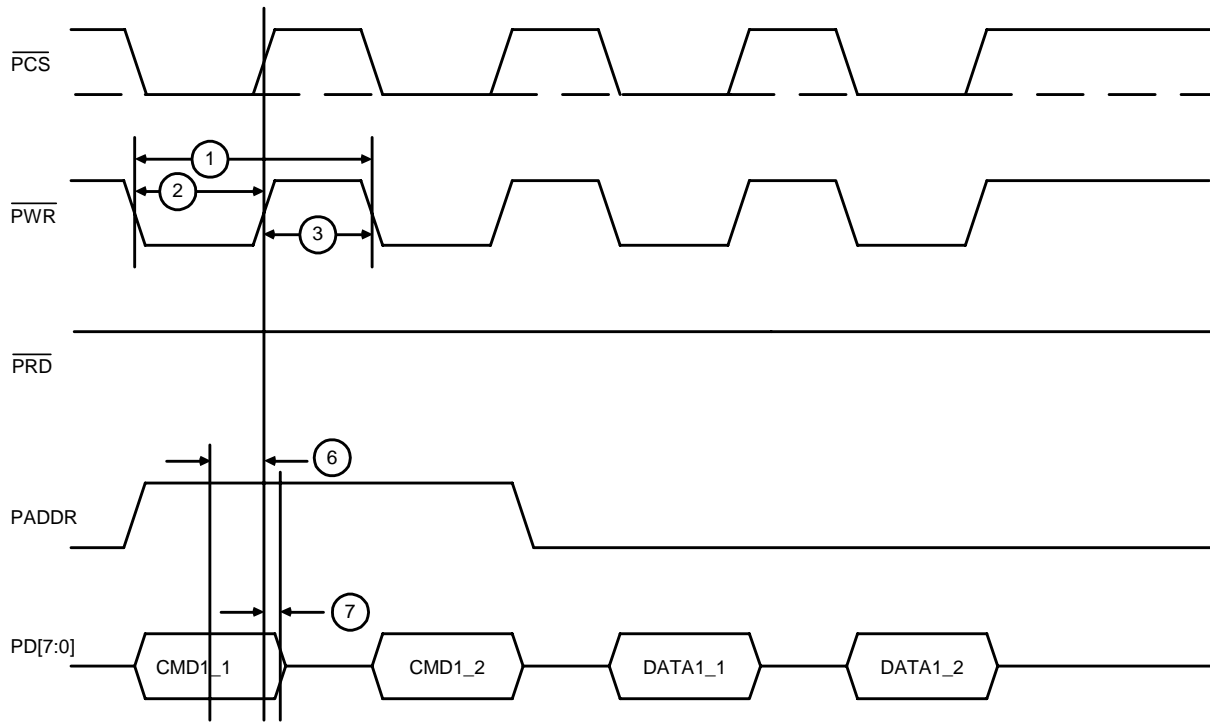

Note: Each Write and Read access is qualified by an active chip select strobe. (Chip select can be tied Low in some applications.)

Figure 10. GPI 8-Bit Read Access Using Separate Read and Write Strobes

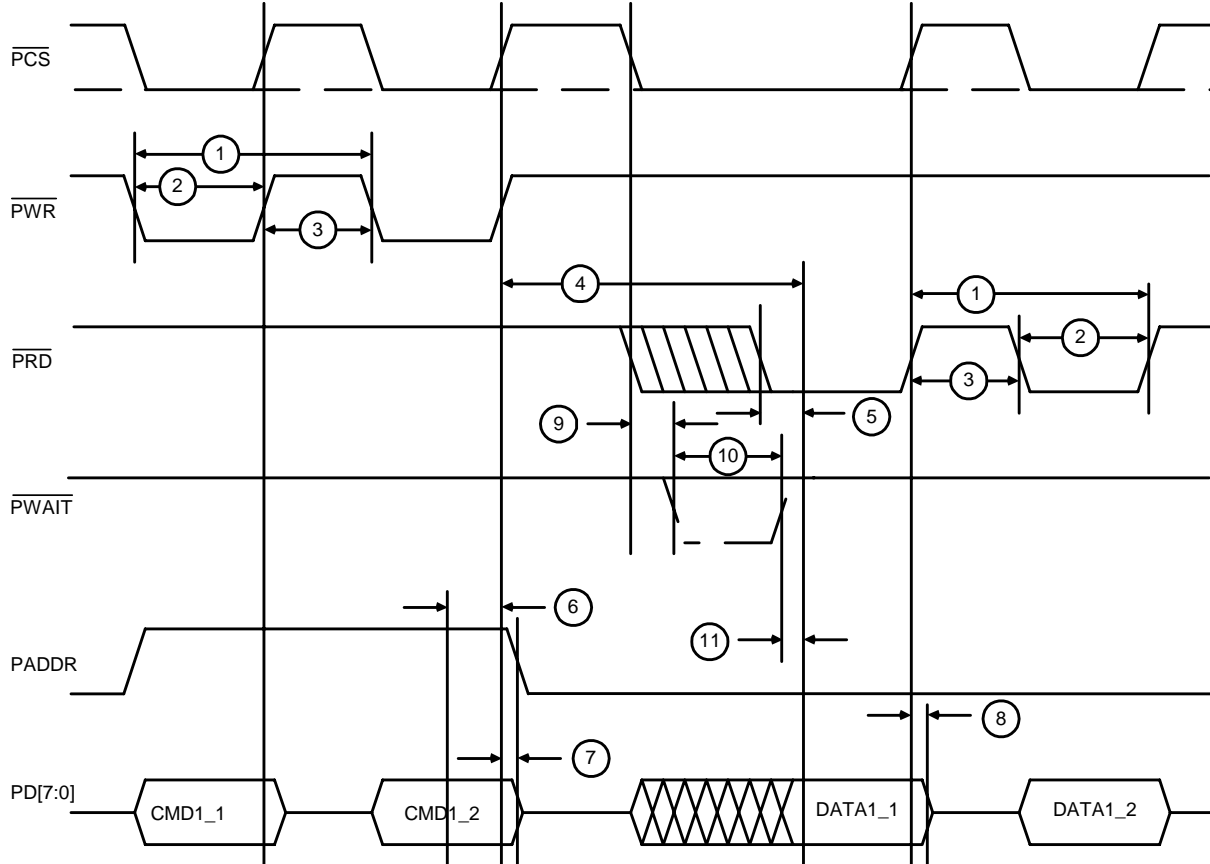

Note: Each Write and Read access is qualified by an active chip select strobe. (Chip select can be tied Low in some applications.)

Table 16. GPI Bus Timing Parameters for Combined Read/Write and Data Strobes¹

No.	Symbol	Parameter	Min	Typ	Max	Unit	Note
1	t_{ACC}	Access period (from Write to Write or Read to Read or Read to Write)	100	—	—	ns	
2	t_{ON}	Pulse width LOW (\overline{PCS} or $\overline{PRD}/\overline{WR}$ or \overline{PDS})	35	—	—		
3	t_{OFF}	Pulse width HIGH (\overline{PCS} & $\overline{PRD}/\overline{WR}$ & \overline{PDS} or \overline{PCS} & \overline{PDS})	10	—	—		
4	t_{WR_RDV}	Write to Read (rising $\overline{PRD}/\overline{WR}$ to Data output valid)	25	—	270		3,4
5	t_{RD_DV}	\overline{PCS} , \overline{PADDR} , $\overline{PRD}/\overline{WR}$ active to Data output valid	—	—	25		3
6	t_{SU_IN}	Address, Data input setup time to rising \overline{PCS} or $\overline{PRD}/\overline{WR}$ or \overline{PDS}	15	—	—		
7	t_{HOLD_IN}	Address, Data input hold time after rising $\overline{PRD}/\overline{WR}$ or \overline{PDS} or \overline{PCS}	0	—	—		
8	t_{HOLD_OUT}	Data output hold time after rising \overline{PDS} or \overline{PCS}	0	—	10		3
9	t_{CS_WAIT}	Chip Select active to Wait active	—	—	25		2,3
10	t_{WAIT}	Wait strobe active width when \overline{PCS} is active	0	80	280		2,3
11	t_{WAIT_DV}	\overline{PWAIT} deserted to Data valid	—	—	0		2

Note:

1. Refer to Figure 26 for timing diagram test points.
2. The Wait Strobe active edge may occur as early as the rising Write Strobe signal if Chip Select is held active.
3. The pin load is assumed to be $C_{load} = 75pF$.
4. This is the time between the read command and the first data word. If \overline{PWAIT} is not used, then the maximum value must be met by the host. If \overline{PWAIT} is used, faster transactions can occur.

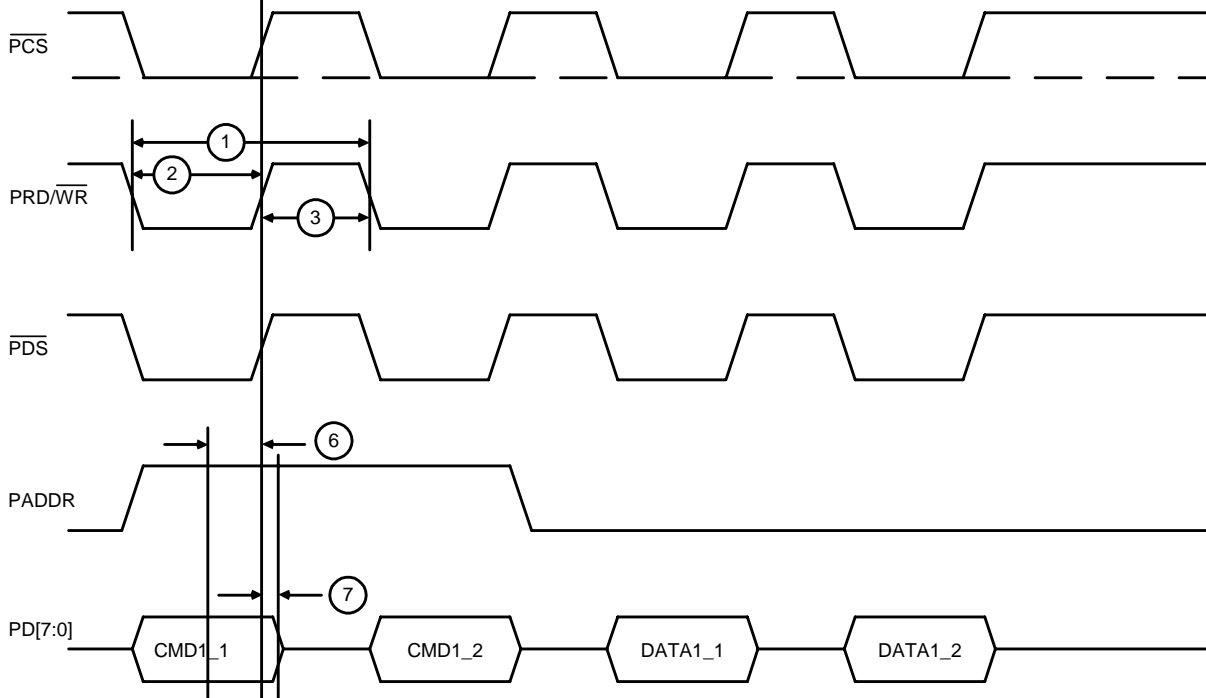
Figure 11. GPI 8-Bit Write Access Using Combined Read/Write and Data Strobes

Note: Each Write and Read access is qualified by an active chip select strobe. (Chip select can be tied Low in some applications.)

Figure 12. GPI 8-Bit Read Access Using Combined Read/Write and Data Strobes

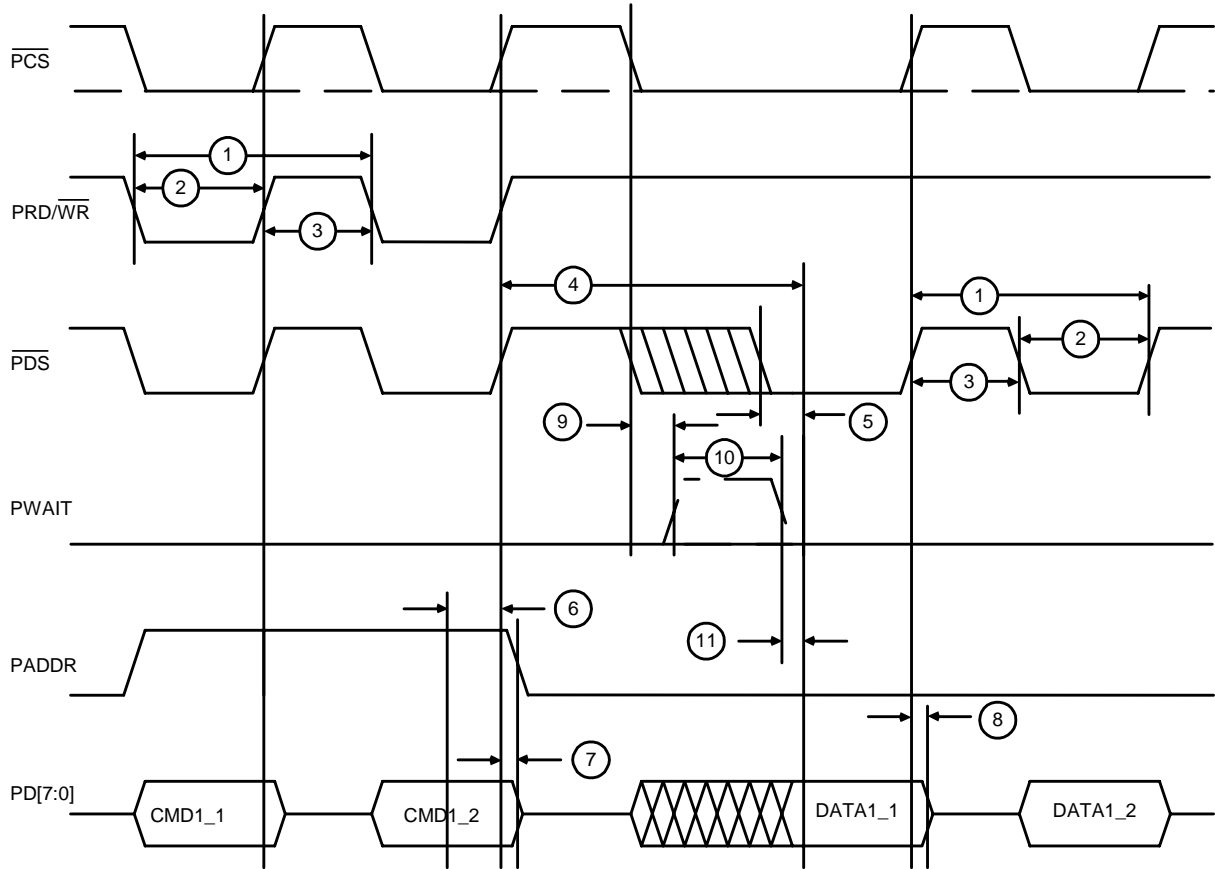

Note: Each Write and Read access is qualified by an active chip select strobe. (Chip select can be tied Low in some applications.)

Figure 13. GPI Read Status Register Access

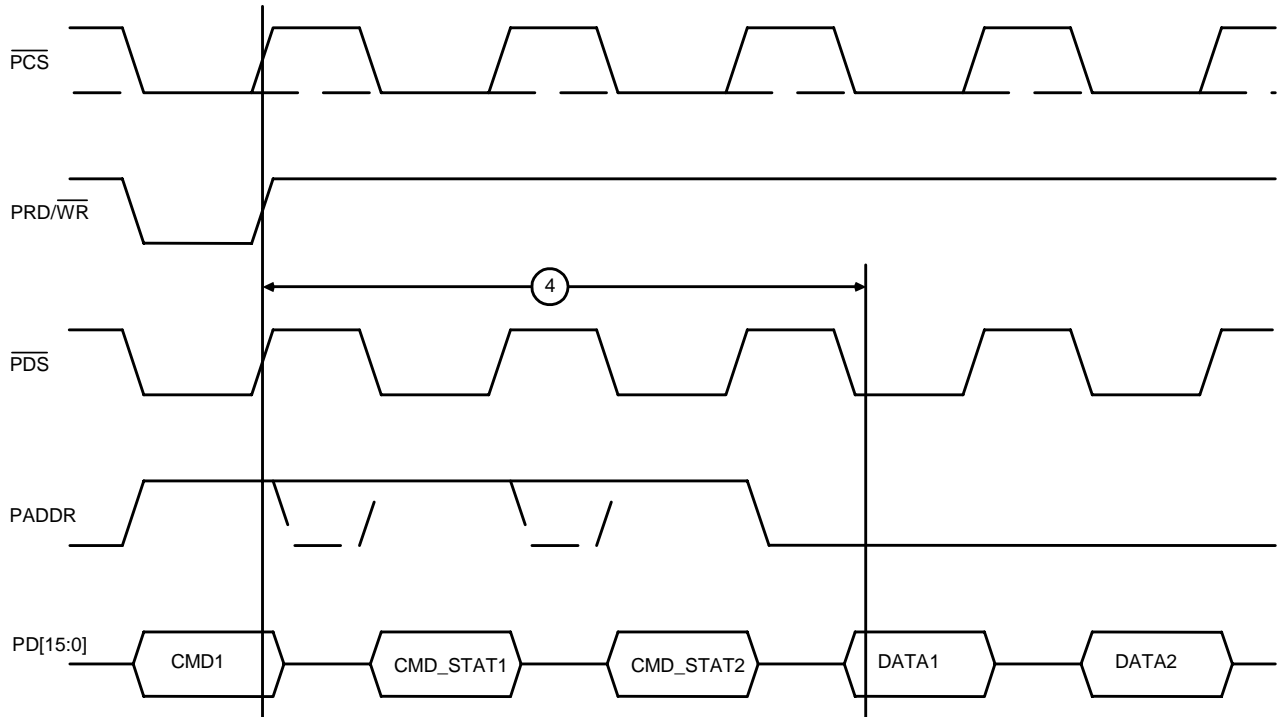

Note: Each Write and Read access is qualified by an active chip select strobe. (Chip select can be tied Low in some applications.)

Figure 14. GPI Data Byte Swap Access

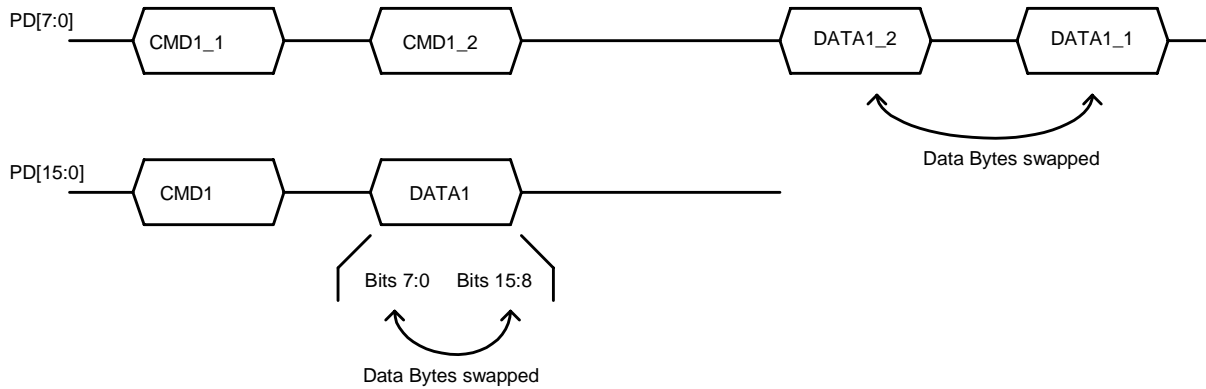

Serial Peripheral Interface (SPI)

Serial Peripheral Interface (SPI) is a physical interface of the VCP device used by the external host to communicate with the device. The SPI interface is compatible with the SPI interface used by general DSPs, so that those chips can interface with the VCP device without any glue logic. Because the SPI has the same logical view as the General Purpose Parallel Interface (GPI), the host can issue the same commands or data to the VCP device regardless of the physical interface.

SPI External Pins Connection

The SPI is a 4-wire synchronized serial interface used in many DSPs and microcontrollers. The data is transferred bi-directional from master to slave and from slave to master. The master provides clock SCK to synchronize the data transfer, and the signals MOSI and MISO are for the data bit stream. SPI master can be a 3-wire or 4-wire SPI master, depending on if the master drives the \overline{SS} signal. A 4-wire SPI master pulls \overline{SS} Low when transferring data. In a single master/slave pair the master can be a 3-wire interface, with the \overline{SS} pin at the slave tied Low.

Table 17. SPI Signals

Signal Name	Type	Description
SCK	Input	SPI clock
MOSI	Input	SPI slave input/master output
MISO	Output	SPI slave output/master input
SS	Input	SPI Slave select low

The VCP device will be the SPI slave, and the external host will be the SPI master. Signal MOSI will connect to the SI pin and signal MISO will connect to the SO pin of the VCP device. Microsemi VCP devices sample the input signal SI on the rising edge of the clock and change the output signal SO on the falling edge of the clock.

[Figure 15](#) shows the SPI interface system with a 4-wire SPI master. When the VCP device supports command framing on the \overline{SS} pin, a 3-wire interface as shown in [Figure 16, on page 37](#) can be utilized.

Figure 15. 4-Wire Master-Slave Connections

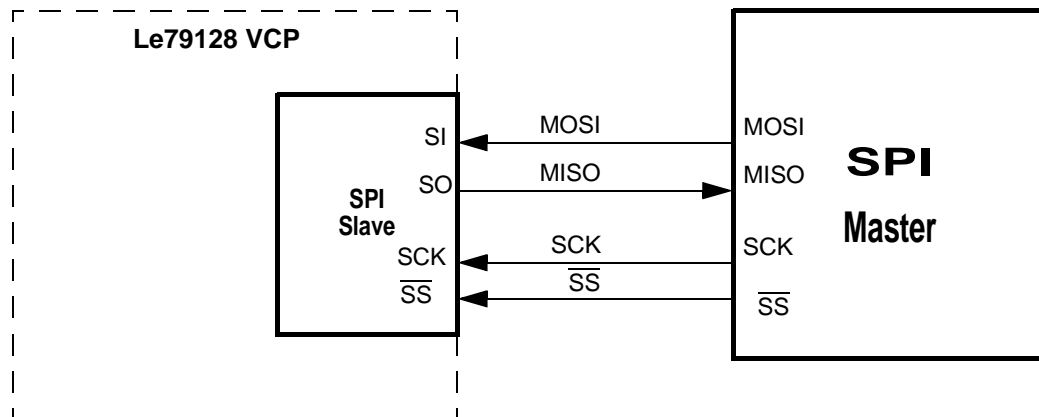
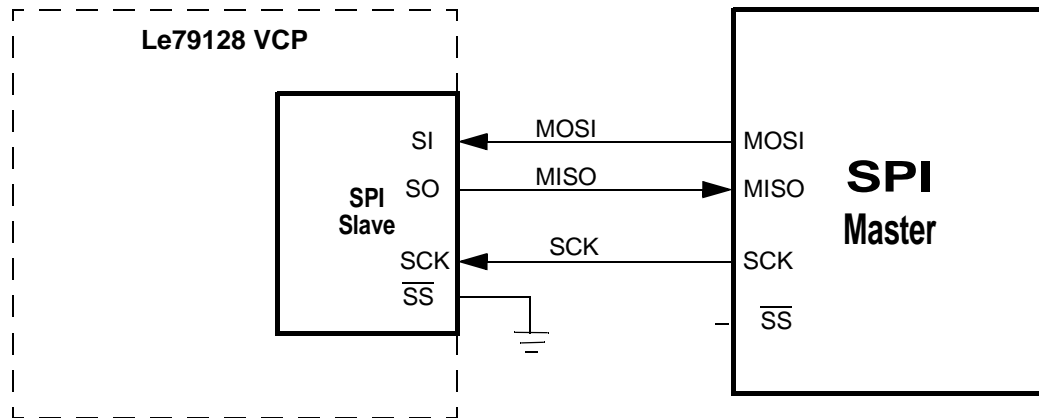

Figure 16. 3-Wire Master-Slave Connections



SPI Features

In order to connect to different SPI masters and share the same logic view with the General Purpose Parallel Interface, the SPI slave of the VCP device has the following designs:

- Separate SI and SO pins.
- No read latency: no latency between the read command word and the first data word.
- Data byte swap is supported.
- \overline{SS} pin supports byte/word framing, and command framing mode, as shown in Figure 17. The SPI slave state machine will reset if \overline{SS} returns to High when the number of active SCK clocks is not equal to 8 or 16. If there is no clock, \overline{SS} has to be Low for more than 125 ns to be recognized to reset SPI slave state machine. In command framing mode, the transition of \overline{SS} to High means the command has ended. This event resets the SPI slave state machine, and the next falling edge of \overline{SS} starts a new command.

Figure 17 shows three kinds of framing modes based on the behavior of \overline{SS} . In byte/word framing mode, \overline{SS} is Low for 8/16 SCK clocks. For a two-word command, \overline{SS} needs to toggle 4/2 times to complete the command transfer. In command framing mode, \overline{SS} is Low for the whole duration of the command transfer. When the command is finished, \overline{SS} will go back to High. If \overline{SS} Low lasts shorter than the expected command length, the command is aborted and the SPI slave state machine resets. However, if the user pulls \overline{SS} Low longer than the expected command length, the extra words will start a new command sequence. In both word framing mode and command framing mode, SCK can be free-running or absent when \overline{SS} is inactive High.

Every time \overline{SS} returns to High and the number of active SCK clocks is not equal to 8 or 16, the SPI slave state machine will reset. The next \overline{SS} Low starts a new command sequence. In command framing mode, the transition back to High means the end of the command. If \overline{SS} Low lasts less than 16 SCK clock cycles, no command byte is processed. If \overline{SS} Low lasts more than 16 clock cycles, each 16-clock cycles triggers the SPI slave to process the word until \overline{SS} returns back to High. The SPI slave will not reset the state machine when \overline{SS} Low lasts exactly 8 or 16 SCK clock cycles to support byte/word framing mode. In byte/word framing mode, the user has to be aware of the command length, as there is no indication of command boundary. For this reason, command framing is recommended.

Figure 17. \overline{SS} Framing Modes

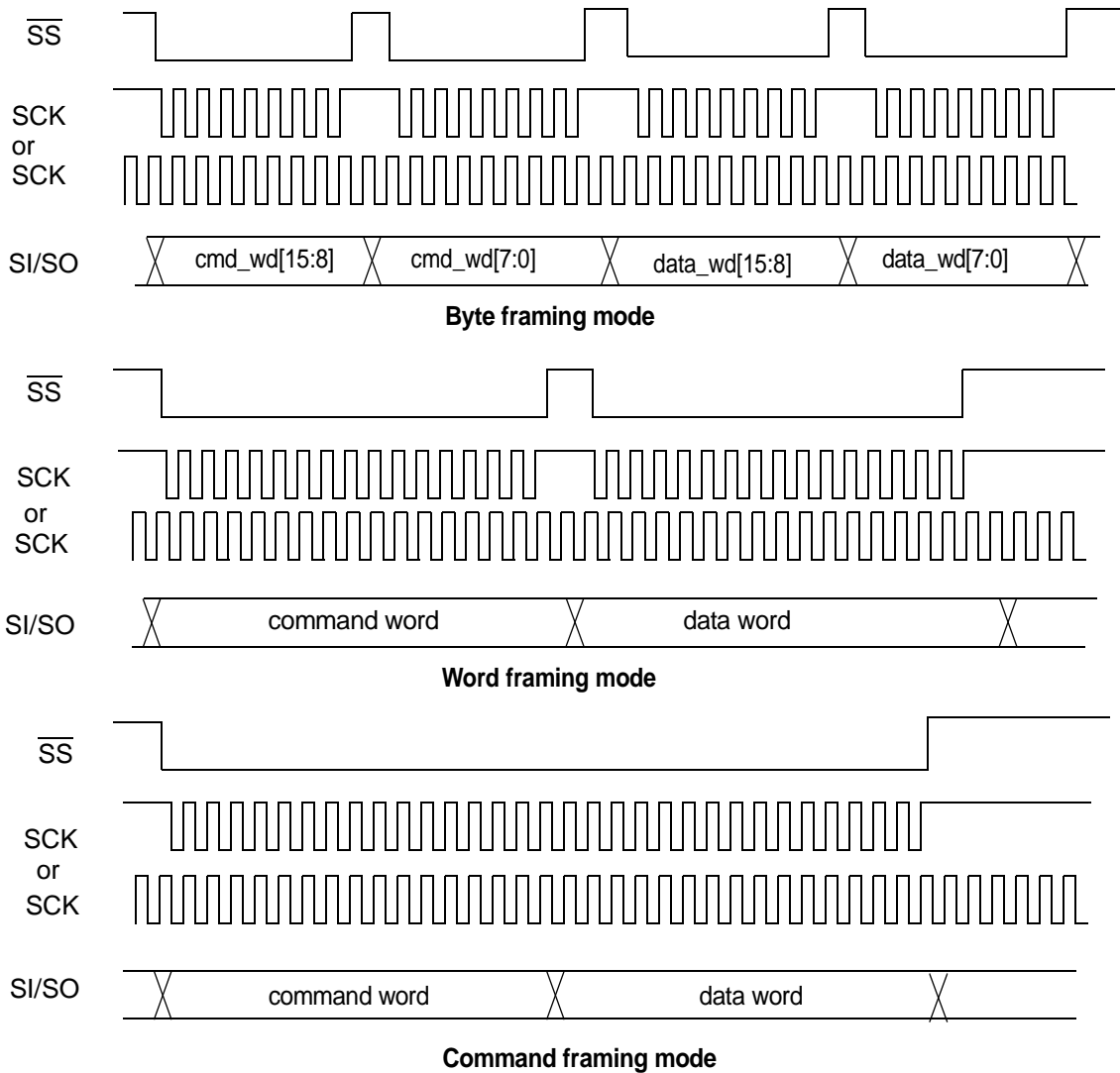

SPI Timing Requirements

The timing requirements for read and write accesses are shown in the following timing diagrams. The single data word read and write command is shown in [Figure 18](#) and [Figure 19](#). The data word can have data bytes swapped like the single data word write command in [Figure 20](#). Bits 7:0 of the data word comes out first and bits 15:8 of the data word come out second. The timing information for the read/write command is in [Figure 21](#), [Figure 22](#), and [Table 18](#).

Figure 18. One Data Word Write in Byte Framing Mode

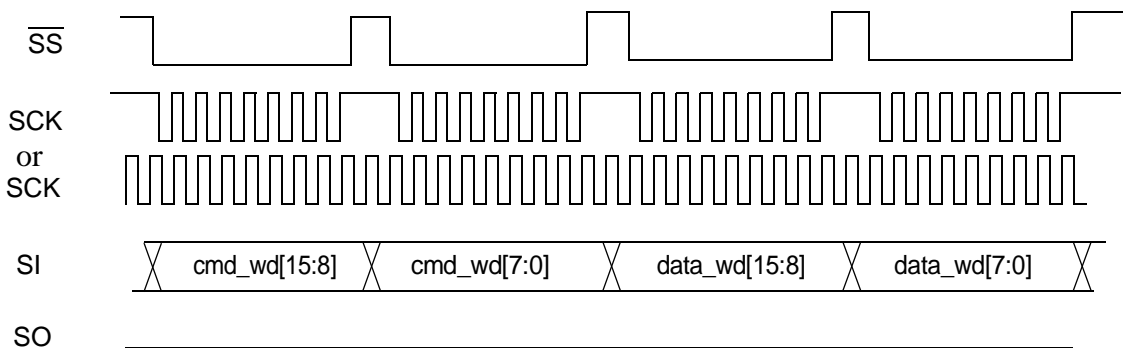

Figure 19. One Data Word Read in Word Framing Mode

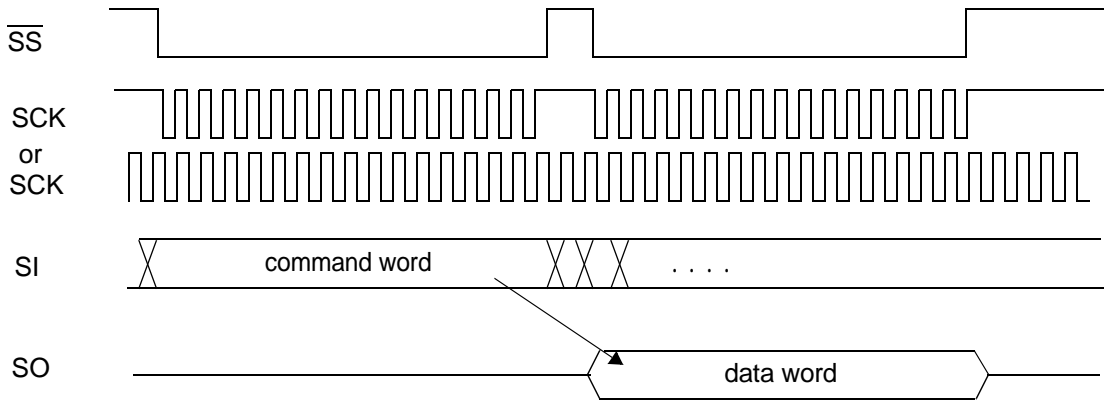

Figure 20. One Data Word Write in Byte Framing Mode with Byte Swap

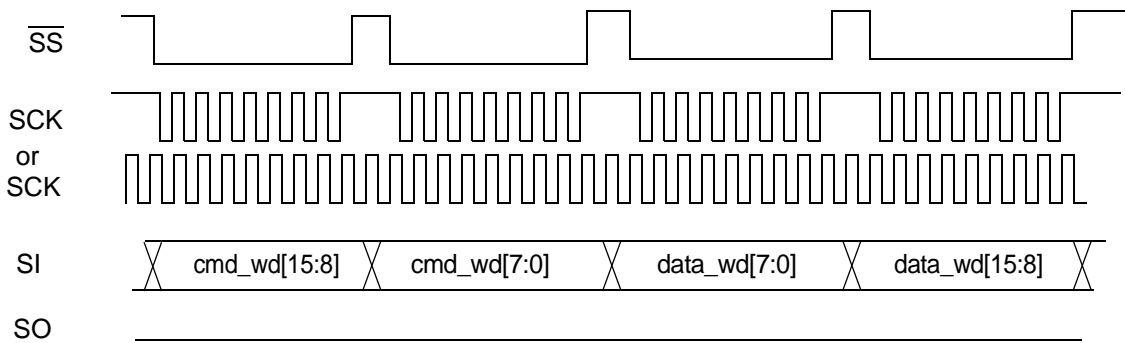

Table 18. SPI Timing Parameters¹

No.	Symbol	Parameter	Min	Typ	Max	Unit	Note
1	t_{DCY}	Serial clock period	61	—	—	ns	
2	t_{DCH}	Serial clock HIGH pulse width	10	—	—		2
3	t_{DCL}	Serial clock LOW pulse width	24	—	—		2
4	t_{DCR}	Rise time of clock	—	—	8		
5	t_{DCF}	Fall time of clock	—	—	8		
6	t_{ICSS}	Slave select setup time	11	—	$t_{DCY}-15$		
7	t_{ICSH}	Slave select hold time	2	—	$t_{DCY}-15$		
8	t_{ICSL}	Slave select pulse width	—	—	—		5
9	t_{ICSO}	Slave select off time	61	—	—		2,4
10	t_{IDS}	Input data setup time	14	—	$t_{DCY}-15$		
11	t_{IDH}	Input data hold time	2	—	$t_{DCY}-15$		
12	t_{ODD}	Output data turn on delay	—	—	15		3, 6
13	t_{ODH}	Output data hold time	2	—	—		6
14	t_{ODOF}	Output data turn off delay	0	—	10		6
15	t_{ODC}	Output data valid	2	—	15		6

Notes:

1. Refer to Figure 26 for timing diagram test points.
2. SCK may be stopped in the High or Low state indefinitely without loss of information. When \overline{SS} is at Low state, every 16 SCK cycles the 16-bit received data will be interpreted by the SPI interface logic.
3. The first data bit is enabled on the falling edge of \overline{SS} or on the falling edge of SCK, whichever occurs last.
4. The SPI slave requires 61ns \overline{SS} Off time just to make the transition of \overline{SS} synchronized with SCK clock. In the command framing mode, there is no \overline{SS} Off time between each 16-bit command/data and \overline{SS} is held low until the end of command.
5. If \overline{SS} is not held Low for 16 or 8 SCK cycles exactly, the SPI slave will reset. During byte or word framing mode, \overline{SS} is held Low for 8 or 16 SCK cycles. During command framing mode, \overline{SS} is held Low for the whole duration of the command. Besides, multiple commands can be transferred with \overline{SS} low for the whole duration of the multiple commands. The rising edge of the \overline{SS} indicates the end of the command sequence and resets the SPI slave.
6. Pin loading is assumed to be $C_{load} = 75pF$

Figure 21. SPI Interface (Input Timing)

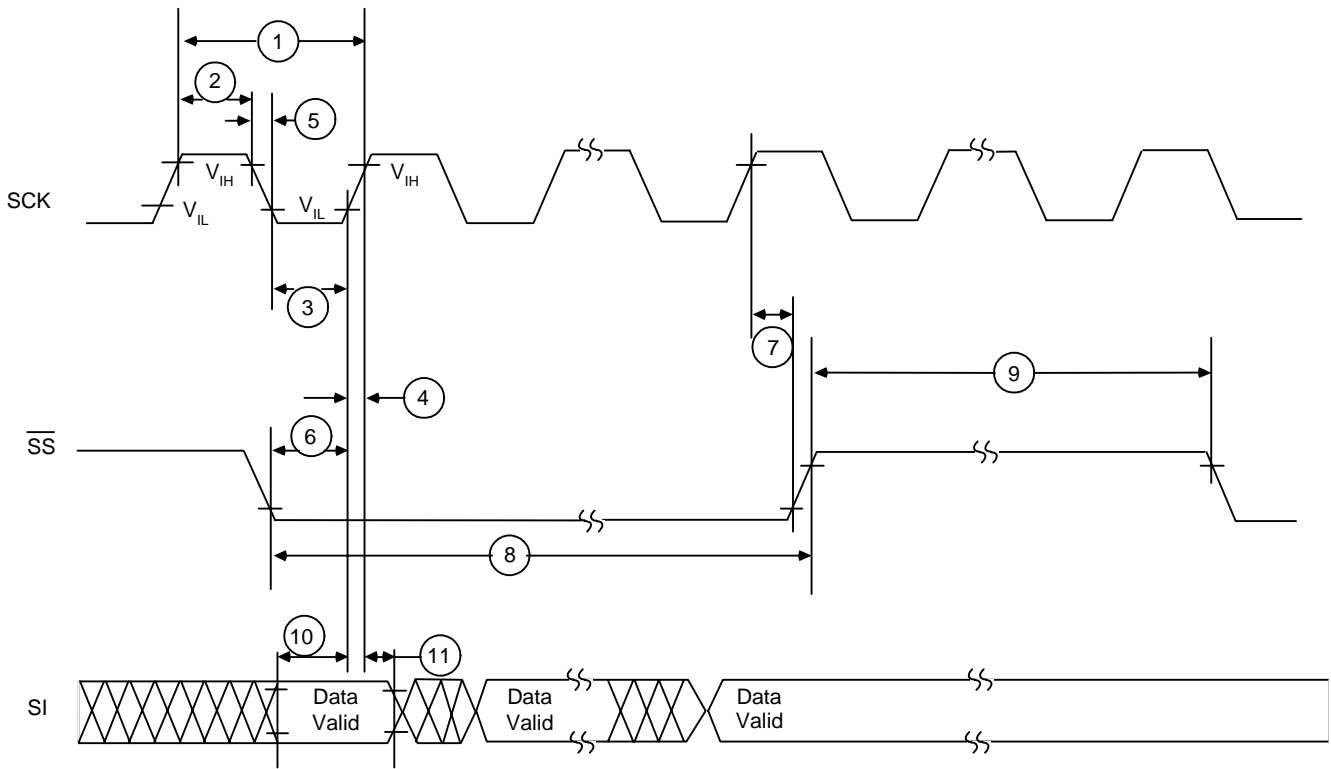
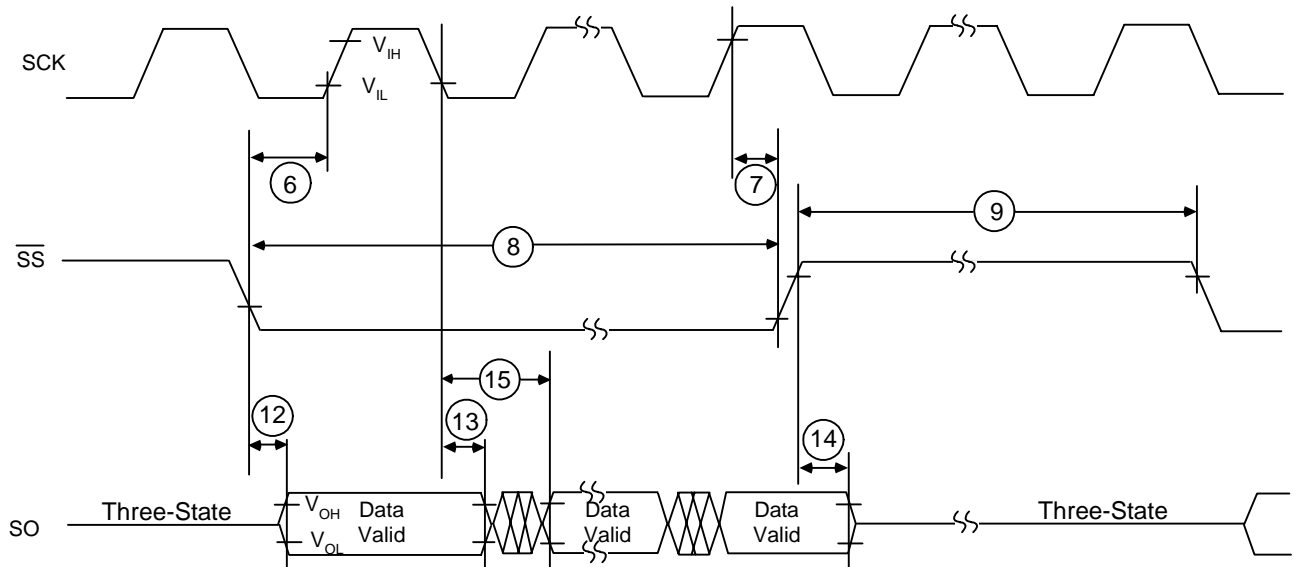

Figure 22. SPI Interface (Output Timing)



SPI1 and SPI2 Timing

Two Master SPI blocks are provided to communicate with the MPI interfaces of up to 8 OISLAC devices each. This interchip highway carries control information between the VCP and the SLAC devices. Timing will be met as long as loading and signal integrity issues are properly handled on the printed circuit board.

Table 19. SPI1 and SPI2 Timing Parameters¹

No.	Symbol	Parameter	Min	Typ	Max	Unit	Note
1	t_{DCY}	Data clock period	114	129	3657.1	ns	
2	t_{DCH}	Data clock ON pulse width	34	—	1809		
3	t_{DCL}	Data clock OFF pulse width	77	—	1852		
	t_{DCR}	Rise time of clock	—	—	5		2
			—	—	8		3
	t_{DCF}	Fall time of clock	—	—	5		2
			—	—	8		3
4	t_{CSS}	Chip select setup to first clock edge	62	—	—		2
			62	—	—		3
5	t_{CSO}	Chip select output delay	2	—	15		
6	t_{MOSIS}	Data output setup to first clock edge	50	—	—		2
			50	—	—		3
7	t_{MOSIH}	Data output hold time	1	—	15		2
			1	—	15	3	
8	t_{MISOS}	MISO/MOSI(3-wire) input setup time	15	—	—		
9	t_{MISOH}	MISO/MOSI(3-wire) input hold time	0	—	—		

Note:

1. Refer to Figure 26 for timing diagram test points.
2. Assumes 40-pF load on SPI_CLK, SPI_MOSI, and SPI2_ \overline{CS} or GPIO[31:16].
3. Assumes 150-pF load on SPI_CLK and SPI_MOSI, but 40-pF load on SPI2_ \overline{CS} or GPIO[31:16]. Assumes a 50 Ω series termination at output of SPI_CLK.

Timing Requirements

Figure 23. SPI Timing Waveforms

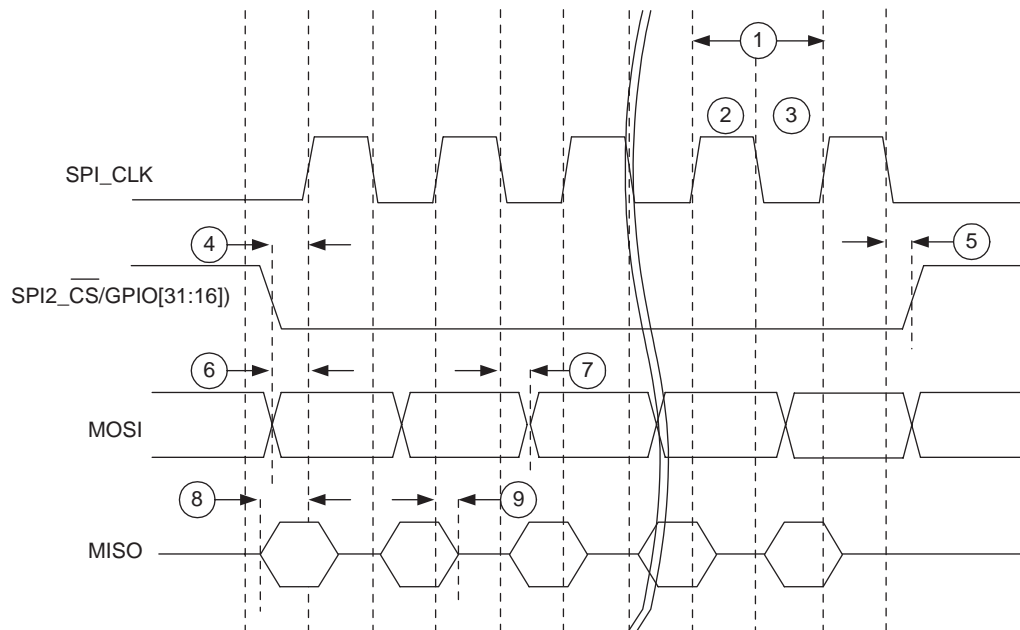

PCM INTERFACE

Two PCM blocks reside on the Le79128 device. There is a Slave PCM Highway A/Redundant block comprised of the PCLKA, FSA, DXA, DRA, TSCXA, TSCRA, PCLKB, FSB, DXB, DRB, TSCXB, and TSCRB pins, and a block used as the Slave PCM Highway B comprised of the MPCLK, MFS, MDX, and MDR pins. The Slave PCM Highway A/Redundant block requires PCLKA or PCLKB as inputs. The Slave PCM Highway B requires MPCLK as an input. In hardware, MPCLK and MFS can be configured as outputs, therefore specifications for output use are provided in [Table 20](#). Refer to the *Next Generation Carrier Chipset Hardware Design Guide* for diagrams on supported PCM Highway usage.

The Redundant highway is useful if the A highway suffers a system failure. PCLKA and PCLKB are closely monitored by CLKGEN to perform an automatic highway switch (if desired) when the selected highway fails.

The Slave PCM Highway A/Redundant block provides backplane driver tristate control outputs \overline{TSCXA} and \overline{TSCXB} when DXA or DXB are active respectively. The Slave PCM Highway B block does not have a redundant backup or the tristate control outputs.

Timing for these blocks is shown in [Figure 24](#) and [Table 20](#). PCLK accuracy = ± 100 PPM.

Table 20. PCM Interface Timing Parameters¹

No.	Symbol	Parameter	Min.	Typ	Max	Unit	Note
1	t_{PCY}	PCLKx or MPCLK period	61	—	1953.1	ns	2,4,6,7
			122	—	1953.1		2,5,6,7
2	t_{PCH}	PCLKx or MPCLK HIGH pulse width	24	—	—		4
			48	—	—		5
3	t_{PCL}	PCLKx or MPCLK LOW pulse width	24	—	—		4
			48	—	—		5
	t_{PCF}	Fall time of PCLKx (Input)	—	—	8		
	t_{PCR}	Rise time of PCLKx (Input)	—	—	8		
	t_{MPCF}	Fall time of MPCLK (Output)	—	—	8		10
	t_{MPCR}	Rise time of MPCLK (Output)	—	—	8		10
4	t_{FSD}	FS delay (Output rising or falling)	2	—	15		4
			2	—	25		5
5	t_{FSS}	FS setup time (Input)	11	—	$t_{PCY}-2$		
6	t_{FSH}	FS hold time (Input)	0	—	—		
7	t_{DOH}	Data output hold time	5	—	16		4
			5	—	25		5
8	t_{DOZ}	Data output delay to high-Z	0	—	10		3
9	t_{TSCD}	TSC output delay	5	—	16		4
			5	—	25		5
10	t_{TSCZ}	TSC output delay to high-Z	0	—	10		
11	t_{DIS}	Data input setup time	10	—	—	9	
12	t_{DIH}	Data input hold time	10	—	—	9	
	t_{PCT}	Allowed PCLK jitter time	-97	—	97	7	
	t_{FST}	Allowed Frame sync jitter time	$-t_{PCY}/2$	—	$t_{PCY}/2$	8	

1. Refer to Figure 26 for timing diagram test points.
2. The PCM clock (PCLK) frequency must be an integer multiple of 512 kHz +/- 6000 ppm and be specified to within 100ppm. The minimum clock frequency is 512 kHz. The maximum clock frequency is limited by software to 8.192 MHz.
3. \overline{TSC} is an open drain driver. t_{TSD} is defined as the delay time the output driver turns off after the PCLK transaction. The actual delay time is dependent on the load circuitry. The minimum pull-up resistance to VDD is 360 Ω .
4. $C_{load} = 40$ pF
5. $C_{load} = 150$ pF
6. If PCLK is used to drive the main system clock, it must be present at all times to maintain proper internal operation. A total clock failure will result in a 60% reduction in internal MIPs within 125 μ s. If the clock failure can be restored within 2 μ s, a MIP drop of only 1% will result. The VCP device has the capability to detect an abrupt frequency change greater than 8% and switch within 2 μ s.
7. Maximum PCLK jitter is +/- 97ns or 1/2 of the PCLK period whichever is less.
8. The number of PCLKs per FS period may deviate by 1 clock (not by +/-1 which would be 2).
9. Data input setup and hold times occur within a sampling window which is referenced to an internal clock. Setup and hold times are specified assuming standard firmware usage.
10. Assumes 150-pF load on MPCLK and a 50 Ω series termination at output of MPCLK.

Figure 24. PCM Highway Timing

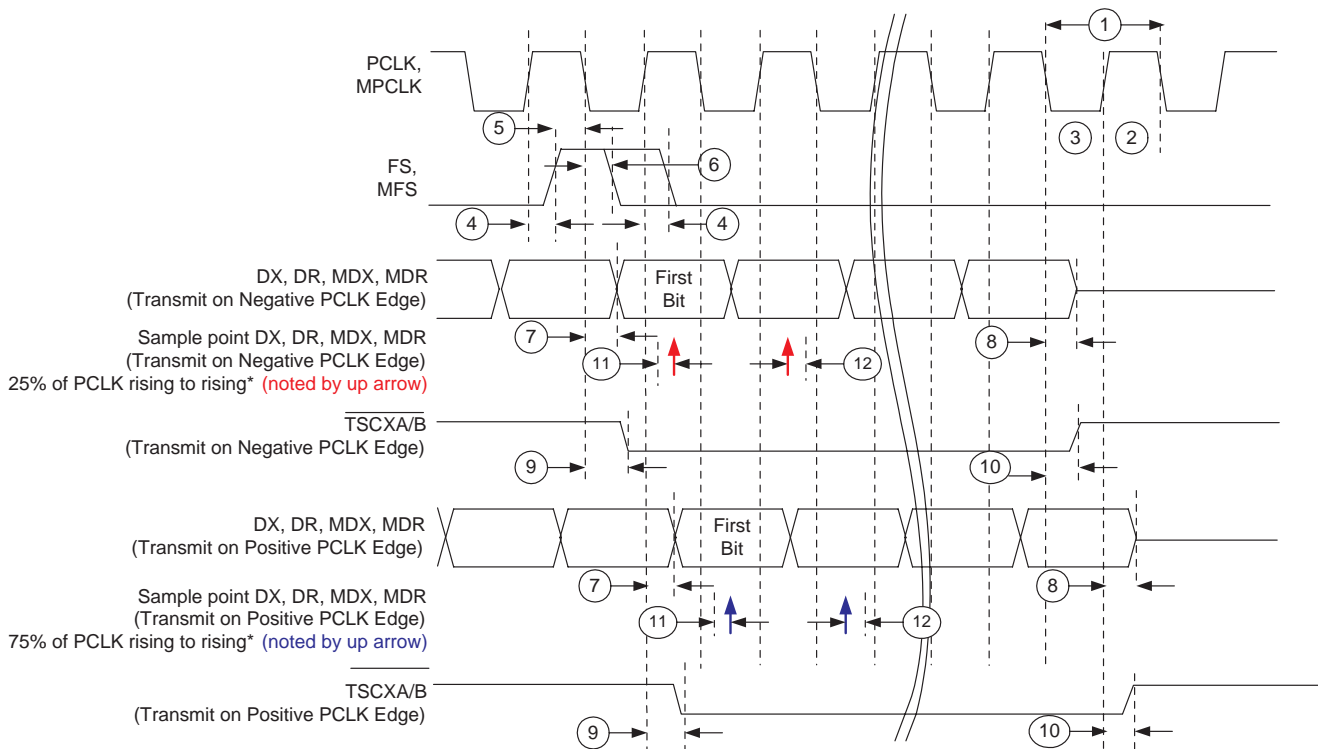

*Because the receive sampling point is defined from the rising edge, the clock duty cycle may affect timing relative to the negative edge of the clock

THE VCP DEVICE INTERRUPT REPORT AND SERVICE MECHANISM

There are two types of interrupt generated in the VCP device: the System Interrupt and the Event Interrupt.

The System Interrupts are hardware implemented and are maskable. Multiple System Interrupt sources may be reported simultaneously.

The Event Interrupts are defined by the application and are reported one at a time. Three Event queues allow these interrupts to be spooled off in the order they were received, per priority level.

An interrupt is normally reported to the host whenever there is any outstanding interrupt in the System Interrupt Source register or one of the event queue interrupt fifo. An "event_delay" bit exists so that the lowest 2 event queues will not assert an interrupt until a system or queue one interrupt occurs. This second option reduces the number of interrupts received by the host processor to only the number of higher priority events. Interrupt to the external host is level sensitive. The $\overline{\text{INT}}$ pin remains High if there is no pending interrupt. When an interrupt occurs, the $\overline{\text{INT}}$ pin is pulled Low to signal the external microcontroller that an interrupt has occurred. Reading the interrupt indication register by the external microcontroller clears the interrupt. After reading the interrupt indication register by the external microcontroller, the $\overline{\text{INT}}$ pin will go High if there is no pending interrupt. The $\overline{\text{INT}}$ pin will continuously stay Low if there is another pending interrupt.

Interrupts are reported based on their priority. System interrupts have the highest priority. For the event interrupts, event queue 1 has the highest priority and event queue 3 has the lowest priority. The interrupt signal is latched before reporting to the host through the $\overline{\text{INT}}$ pin.

DEBUG INTERFACE

This port is for debug use only. If debug of VCP operation becomes necessary, Microsemi may require access to this port.

Two Debug port access methods are presented.

The board can be laid out with a population option debug header and with population option pull-up and pull-down resistors. This interface is detailed in Figure 25. The 14-pin header pins should be spaced 2.54 mm (100 mils) row to row and 2.54 mm (100 mils) column to column.

An alternate approach is to simply bring TCK, TMS, TDI, TDO, and $\overline{\text{TRST}}$ pins out to test points with $\overline{\text{TRST}}$ tied to digital ground through a 1 K Ω resistor. This will allow easy access if it becomes necessary to jumper to the Debug port.

Figure 25. VCP Debug Port - Optional Header Interface

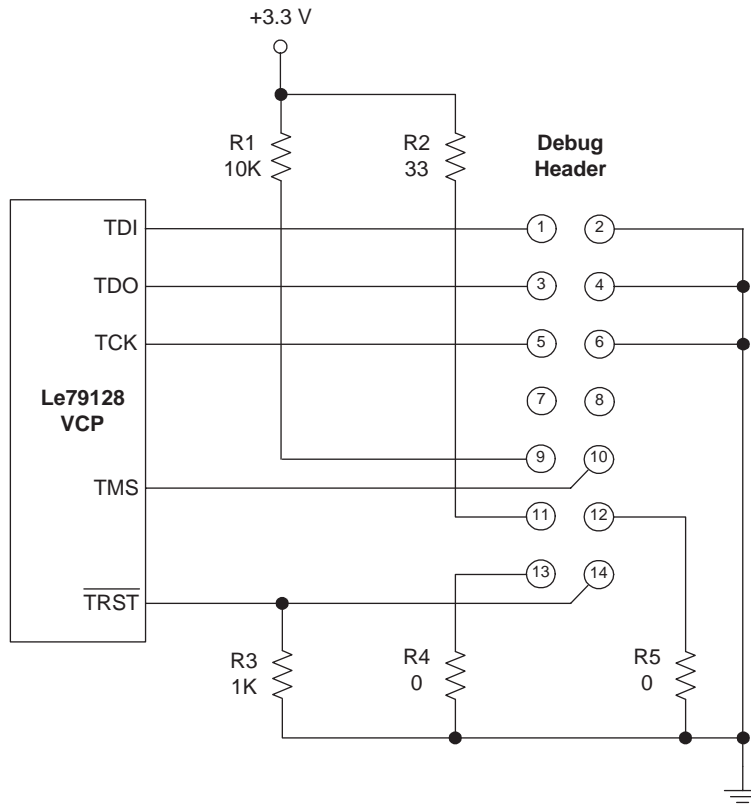

TIMING DIAGRAM TEST POINTS

DVDD = PLL_VDD = 3.3 V \pm 5%, PLL_VSS = DVSS = 0 V.

Figure 26. Timing Diagram Test Points

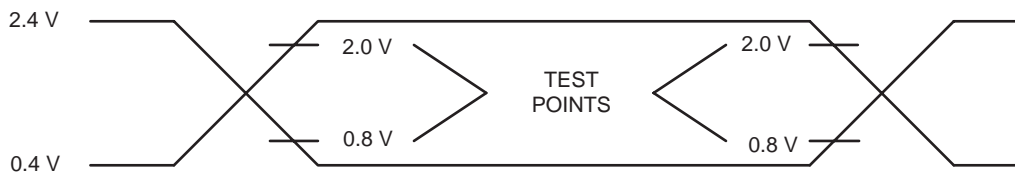

TROUBLESHOOTING AT INITIAL START-UP

Verify that the power supplies and the Configuration pins are appropriately set. Configuration pins must be set before releasing the VCP device from reset.

Next perform the following steps to check that the VCP can be read and written through the HBI.

1. Probe the PWAIT pin. With reset inactive, perform a write of 0x04 to the Configure Interface register (CMD 0xFD04). This should result in the PWAIT pin going High; writing 0x06 (CMD 0xFD06) will make PWAIT go Low. This verifies the basic HAL function - VpHalHbiCmd().
2. With reset inactive, perform a read of the CMD register. This should return 0x0002 (the 2 bit is the interrupt pin status—it should be High, inactive). To read the CMD register in 8-bit mode, perform two back to back 8-bit reads of the CMD register location. For this step, no HAL function needed, simple address read.
3. Write to the Page register (CMD 0xFEzz - zz being any page number 0 - 0xFF). This write should be reflected in a subsequent read of the CMD register above. A CMD of 0xFEAA should result in a read from the CMD register of 0xAA02. This is writing the Page register which gets reflected in a read of the CMD register (again, the read is two 8-bit reads of the CMD register location—the same location read twice).
4. A read of the PCLK-Selection register (CMD 0x8801, followed by two 16-bit reads of the data register) with no PCLK or FS will result in a value of 0x92FB 0x92FB. If both PCLK and FS are present, then the value read will be the exact PCLK detected by the device (see page 21 or 22 for returned value). This step reads two words using HAL function - VpHalHbiRead(). The command to read the PCLK registers (A and B) is 0x8801 to read two words. Word 0 is PCLKB and will return the exact PCLK detected by the VCP or 0x92FB if PCLKB is not present. Word 1 is PCLKA and will return the exact PCLK detected by the VCP or 0x92FB if PCLKA is not present.

If the four steps above were completed successfully, the VCP device is now functional.

Finally, run the quickstart application that is provided in the package and boot-load the API image. This provides verification of the VCP firmware image download and execution, the MPI to SLAC interface, and the integrity of the PCM highways and the voice path. It also verifies basic call control, usage of profiles, DTMF decoding, and line testing. The boot-load is supplied as a binary firmware load to the VCP. It is to be boot-loaded into the VCP along with some C host code to boot-load and control the image.

PHYSICAL DIMENSIONS

128-Pin TQFP

PACKAGE OUTLINE
TQFP 128L
14X14X1.D MM

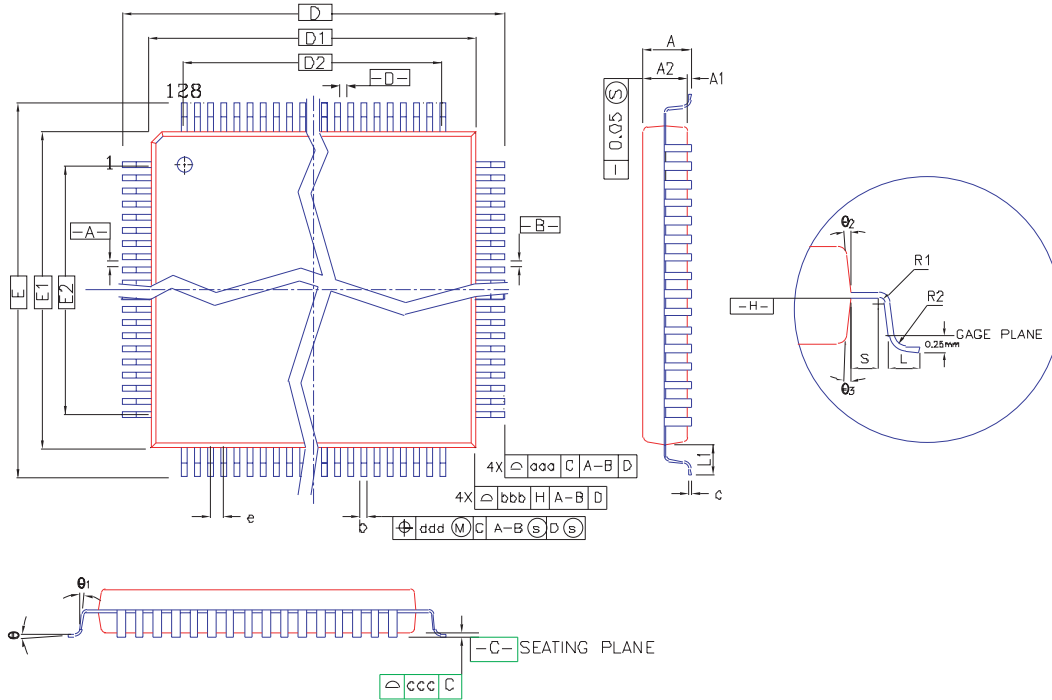

CONTROL DIMENSIONS ARE IN MILLIMETERS.

SYMBOL	MILLIMETER			INCH		
	MIN.	NOM.	MAX.	MIN.	NOM.	MAX.
A	—	—	1.20	—	—	0.047
A1	0.05	—	0.15	0.002	—	0.006
A2	0.95	1.00	1.05	0.037	0.039	0.041
D	16.00 BSC.			0.630 BSC.		
D1	14.00 BSC.			0.551 BSC.		
E	16.00 BSC.			0.630 BSC.		
E1	14.00 BSC.			0.551 BSC.		
R2	0.08	—	0.20	0.003	—	0.008
R1	0.08	—	—	0.003	—	—
θ_1	0°	3.5°	7°	0°	3.5°	7°
θ_2	11°	12°	13°	11°	12°	13°
θ_3	11°	12°	13°	11°	12°	13°
c	0.09	—	0.20	0.004	—	0.008
L	0.45	0.60	0.75	0.018	0.024	0.030
L1	1.00 REF.			0.039 REF.		
S	0.20	—	—	0.008	—	—

SYMBOL	128L					
	MILLIMETER			INCH		
	MIN.	NOM.	MAX.	MIN.	NOM.	MAX.
b	—	0.16	—	—	0.006	—
e	0.40 BSC.			0.016 BSC.		
D2	12.4			0.488		
E2	12.4			0.488		
TOLERANCES OF FORM AND POSITION						
aaa	0.20			0.008		
bbb	0.20			0.008		
ccc	0.08			0.003		
ddd	0.07			0.003		

NOTES :

- DIMENSIONS D1 AND E1 DO NOT INCLUDE MOLD PROTRUSION. ALLOWABLE PROTRUSION IS 0.25mm PER SIDE. D1 AND E1 ARE MAXIMUM PLASTIC BODY SIZE DIMENSIONS INCLUDING MOLD MISMATCH.
- DIMENSION b DOES NOT INCLUDE DAMBAR PROTRUSION. ALLOWABLE DAMBAR PROTRUSION SHALL NOT CAUSE THE LEAD WIDTH TO EXCEED THE MAXIMUM b DIMENSION BY MORE THAN 0.08mm. DAMBAR CAN NOT BE LOCATED ON THE LOWER RADIUS OR THE FOOT. MINIMUM SPACE BETWEEN PROTRUSION AND AN ADJACENT LEAD IS 0.07mm FOR 0.4mm and 0.5mm PITCH PACKAGES.

144-Pin LBG A

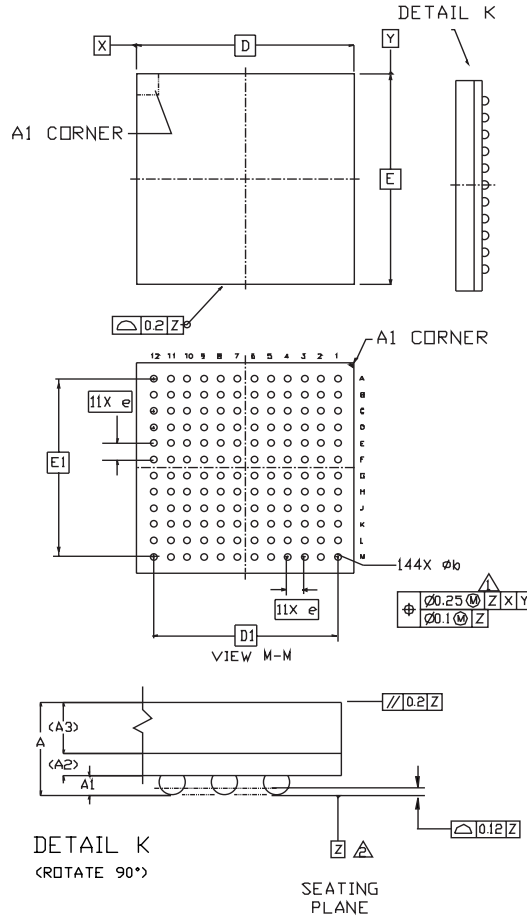

Symbol	144 LBG A	
	Min	Max
A	1.25	1.60
A1	0.27	0.47
A2	0.32 REF	
A3	0.80 REF	
b	0.40	0.60
D	13 BSC	
E	13 BSC	
e	1 BSC	
D1	11 BSC	
E1	11 BSC	

NOTES:

- 1 Dimension b is measured at the maximum solder ball diameter, parallel to datum plane Z.
- 2 Datum Z is defined by the spherical crowns of the solder balls.
- 3 Parallelism measurement shall exclude any effect of mark on top surface of package.

UNIT	DIMENSION AND TOLERANCES	REFERENCE DOCUMENT
MM	ASME_Y14.5M	98ASH70694A-A

Note:

Packages may have mold tooling markings on the surface. These markings have no impact on the form, fit or function of the device. Markings will vary with the mold tool used in manufacturing.

REVISION HISTORY

Version 1 to Version 2

- Changed branding from Zarlink Semiconductor to Microsemi.
- Page 1; Updated Ordering Information.
- Page 1; Updated Related Literature.
- Page 11; Operating Ranges description, changed reliability reference document from "section 4.6.2 of Bellcore TR-TSY-000357" to "Telcordia GR-357-CORE".
- Page 12; DC Specifications, No. 2 & 4, changed Max Input High Voltage from "3.465 V" to "3.6 V".
- Page 26; Code Loading, Table 12, changed Pin terminology to agree with Pin Name in Table 5.



**For more information about all Microsemi CMPG products
visit our Web Site at
www.microsemi.com**

Information relating to products and services furnished herein by Microsemi Corporation or its subsidiaries (collectively "Microsemi") is believed to be reliable. However, Microsemi assumes no liability for errors that may appear in this publication, or for liability otherwise arising from the application or use of any such information, product or service or for any infringement of patents or other intellectual property rights owned by third parties which may result from such application or use. Neither the supply of such information or purchase of product or service conveys any license, either express or implied, under patents or other intellectual property rights owned by Microsemi or licensed from third parties by Microsemi, whatsoever. Purchasers of products are also hereby notified that the use of product in certain ways or in combination with Microsemi, or non-Microsemi furnished goods or services may infringe patents or other intellectual property rights owned by Microsemi.

This publication is issued to provide information only and (unless agreed by Microsemi in writing) may not be used, applied or reproduced for any purpose nor form part of any order or contract nor to be regarded as a representation relating to the products or services concerned. The products, their specifications, services and other information appearing in this publication are subject to change by Microsemi without notice. No warranty or guarantee express or implied is made regarding the capability, performance or suitability of any product or service. Information concerning possible methods of use is provided as a guide only and does not constitute any guarantee that such methods of use will be satisfactory in a specific piece of equipment. It is the user's responsibility to fully determine the performance and suitability of any equipment using such information and to ensure that any publication or data used is up to date and has not been superseded. Manufacturing does not necessarily include testing of all functions or parameters. These products are not suitable for use in any medical products whose failure to perform may result in significant injury or death to the user. All products and materials are sold and services provided subject to Microsemi's conditions of sale which are available on request.

Microsemi, the Microsemi logo, Zarlink, and combinations thereof, Power Matters, SLAC, VeriVoice, VoiceEdge, VoicePort, and VoicePath are trademarks or registered trademarks of Microsemi Corporation. All other trademarks mentioned in this document are the property of their respective owners.

Copyright © 2011. All Rights Reserved

TECHNICAL DOCUMENTATION - NOT FOR RESALE

Microsemi documents marked "Preliminary" relate to products which are not yet released to production and are identified with an "ENG" suffix in their part number. Such products and their associated Preliminary Data Sheet specifications are supplied only for testing and on the express understanding that (i) such products have not been fully tested or characterized under intended modes of operation and may contain defects; (ii) Microsemi makes no representation or warranty regarding such products or Preliminary Data Sheets; and (iii) Microsemi disclaims any liability for claims, demands and damages, including and without limitation special, indirect and consequential damages resulting from any loss arising out of the application, use or performance of such products or specifications. Such products and Preliminary Data Sheets may be changed or discontinued by Microsemi at any time without notice.

Компания «Life Electronics» занимается поставками электронных компонентов импортного и отечественного производства от производителей и со складов крупных дистрибьюторов Европы, Америки и Азии.

С конца 2013 года компания активно расширяет линейку поставок компонентов по направлению коаксиальный кабель, кварцевые генераторы и конденсаторы (керамические, пленочные, электролитические), за счёт заключения дистрибьюторских договоров

Мы предлагаем:

- Конкурентоспособные цены и скидки постоянным клиентам.
- Специальные условия для постоянных клиентов.
- Подбор аналогов.
- Поставку компонентов в любых объемах, удовлетворяющих вашим потребностям.
- Приемлемые сроки поставки, возможна ускоренная поставка.
- Доставку товара в любую точку России и стран СНГ.
- Комплексную поставку.
- Работу по проектам и поставку образцов.
- Формирование склада под заказчика.
- Сертификаты соответствия на поставляемую продукцию (по желанию клиента).
- Тестирование поставляемой продукции.
- Поставку компонентов, требующих военную и космическую приемку.
- Входной контроль качества.
- Наличие сертификата ISO.

В составе нашей компании организован Конструкторский отдел, призванный помогать разработчикам, и инженерам.

Конструкторский отдел помогает осуществить:

- Регистрацию проекта у производителя компонентов.
- Техническую поддержку проекта.
- Защиту от снятия компонента с производства.
- Оценку стоимости проекта по компонентам.
- Изготовление тестовой платы монтаж и пусконаладочные работы.



Тел: +7 (812) 336 43 04 (многоканальный)

Email: org@lifeelectronics.ru