



# Optical Sensor Product Data Sheet LTR-390UV-01

Spec No.: DS86-2015-0004

Effective Date: 02/03/2016

Revision: -

**LITE-ON DCC**

**RELEASE**

BNS-OD-FC001/A4

## OPTICAL SENSOR LTR-390UV-01

### Description

The LTR-390UV-01 is an integrated low voltage I2C ambient light sensor (ALS) and ultraviolet light sensor (UVS) in a single miniature 2x2mm chipled lead-free surface mount package.

This sensor converts light intensity to a digital output signal capable of direct I2C interface. It provides a linear ALS response over a wide dynamic range, and is well suited to applications under high ambient brightness.

The sensor has a programmable interrupt with hysteresis to response to events and that removes the need to poll the sensor for a reading which improves system efficiency. This CMOS design and factory-set one time trimming capability ensure minimal sensor-to-sensor variations for ease of manufacturability to the end customers.

### Application

- Identifying the UV index in ambient light helps people to effectively protect themselves from sunburns, cancer or eye damage.
- To control brightness and color of the display panel in mobile, computing, and consumer devices.

### Features

- I<sup>2</sup>C interface capable of Standard mode @100kHz or Fast mode @400kHz communication; 1.8V logic compatible
- Ambient Light / Ultraviolet light (UVS) Technology in one ultra-small 2x2mm ChipLED package
- Very low power consumption with sleep mode capability
- Operating voltage ranges: 1.7V to 3.6V
- Operating temperature ranges: -40 to +85 °C
- Built-in temperature compensation circuit
- Programmable interrupt function for ALS , UVS with upper and lower thresholds
- RoHS and Halogen free compliant
- **UVS/ALS Features**
  - 13 to 20 bits effective resolution
  - Wide dynamic range of 1:18,000,000 with linear response
  - Close to human eye spectral response
  - Automatic rejection for 50Hz/60Hz lighting flicker

### Ordering Information

Part Number	Packaging Type	Package	Quantity
LTR-390UV-01	Tape and Reel	6-pin chipled package	2500

## OPTICAL SENSOR LTR-390UV-01

### 1. Outline Dimensions

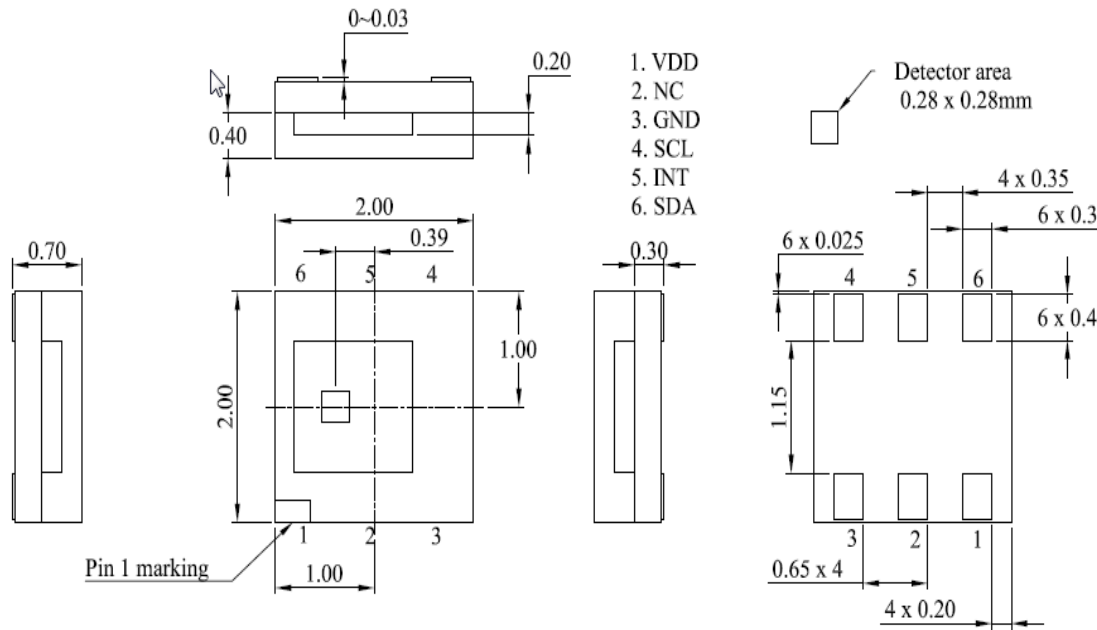

- All dimensions in mm
- Tolerances is +/-0.2
- LTC reserve the right to to change the drawing till final datasheet release

# OPTICAL SENSOR LTR-390UV-01

## 2. Functional Block Diagram

LTR-390UV-01 contains 2 integrated photodiodes (ALS/UVS) for respective photocurrent measurements. The photodiode currents are converted to digital values by ADCs. The sensor also includes some peripheral circuits such as an internal oscillator and voltage reference.

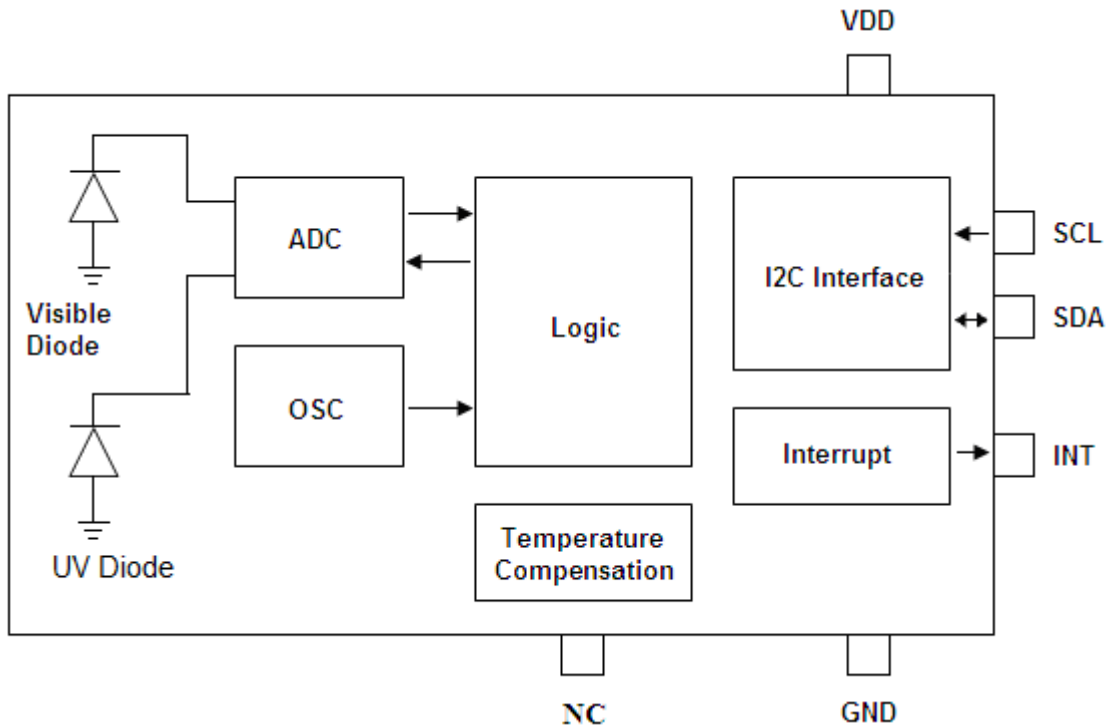

## OPTICAL SENSOR LTR-390UV-01

### 3. Application Circuit

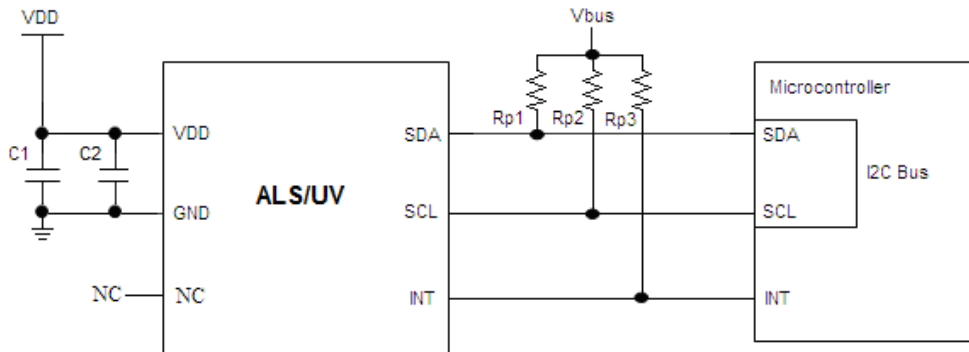

I/O Pins Configuration Table

Pin	I/O Type	Symbol	Description
1		VDD	Power Supply Voltage
2		NC	No connection to this pin
3		GND	Ground
4	I	SCL*	I <sup>2</sup> C serial clock. This pin is an open drain input.
5	O	INT*	Level Interrupt Pin. This pin is an open drain output.
6	I/O	SDA*	I <sup>2</sup> C serial data. This pin is an open drain input / output.

\* Note: For noisy environment, add 10pF capacitor from signal to GND for additional noise filtering.

#### Recommended Application Circuit Components

Component	Recommended Value
Rp1, Rp2, Rp3 [1]	1 kΩ to 10 kΩ
C1	0.1µF
C2	4.7µF

#### Notes:

[1] Selection of pull-up resistors value is dependent on bus capacitance values. For more details, please refer to I2C Specifications: [http://www.nxp.com/documents/user\\_manual/UM10204.pdf](http://www.nxp.com/documents/user_manual/UM10204.pdf)

## OPTICAL SENSOR LTR-390UV-01

### 4. Rating and Specification

#### 4.1. Absolute Maximum Rating at Ta=25°C

Parameter	Symbol	Min.	Max.	Unit
Supply Voltage	VDD		4.0	V
Digital Voltage Range	SCL, SDA, INT	-0.5	4.0	V
Storage Temperature	T <sub>stg</sub>		-45 to 95	°C
Max. Input Current	SCL,SDA,INT	-100	100	mA
Electrostatic Discharge Protection (Human Body Model JESD22-A114)	V <sub>HBM</sub>		2000	V

Note: Exceeding these ratings could cause damage to the sensor. All voltages are with respect to ground. Currents are positive into, negative out of the specified terminal.

#### 4.2. Recommended Operating Conditions

Description	Symbol	Min.	Typ.	Max.	Unit
Supply Voltage	VDD	1.7		3.6	V
Interface signal input high	V <sub>I2Chigh</sub>	1.5		VDD	V
Interface signal input low	V <sub>I2Clow</sub>	0		0.4	V
Operating Temperature	T <sub>ope</sub>	-40		85	°C

#### 4.3. Electrical Specifications (VDD = 2.8V, Ta=25°C, unless otherwise noted)

Parameter	Min.	Typ.	Max.	Unit	Condition
ALS Active Mode Current		110		μA	Max. duty cycle, Vdd=2.8V, Gain 3x
UVS Active Mode Current		100		μA	Max. duty cycle, Vdd=2.8V
Standby Current		1		μA	Standby / Sleep Mode
Wakeup Time from Standby		5	10	ms	From Standby to Active mode where measurement can start

## OPTICAL SENSOR LTR-390UV-01

### 4.4. Characteristics Ambient Light

Parameter	Min.	Typ.	Max.	Unit	Condition
ALS Output Resolution	13	18	20	Bit	Programmable for 13,16,17,18,19, 20 bit
Dark Level Count		0	5	count	0 Lux, T <sub>ope</sub> =25°C, 18-bit range
Calibrated Lux Error In Gain Range 3	-10		10	%	White LED,5000K, T <sub>ope</sub> =+25°C
ALS Accuracy	-25		25	%	Across different light sources
50/60 Hz flicker noise error	-5		5	%	

### 4.5. Characteristics UVS Sensor

Parameter	Min.	Typ.	Max.	Unit	Condition
UVS Output Resolution	13	18	20	Bit	Programmable for 13,16,17,18,19,20 bit
UV Count		160		count	UV LED 310nm, T <sub>ope</sub> =25°C, 18-bit Gain range =18, Irradiance =70uW/cm2
UV Sensitivity		2300		Counts/UVI	Gain range = 18, 20-bit
UVI accuracy	-20		20	%	Gain range = 18, 20-bit for UVI>5
	-1		1	UVI	UVI<5

# OPTICAL SENSOR LTR-390UV-01

## 4.6. Typical Device Parameter

(VDD = 2.8V, Ta=25°C, Default power-up settings, unless otherwise noted)

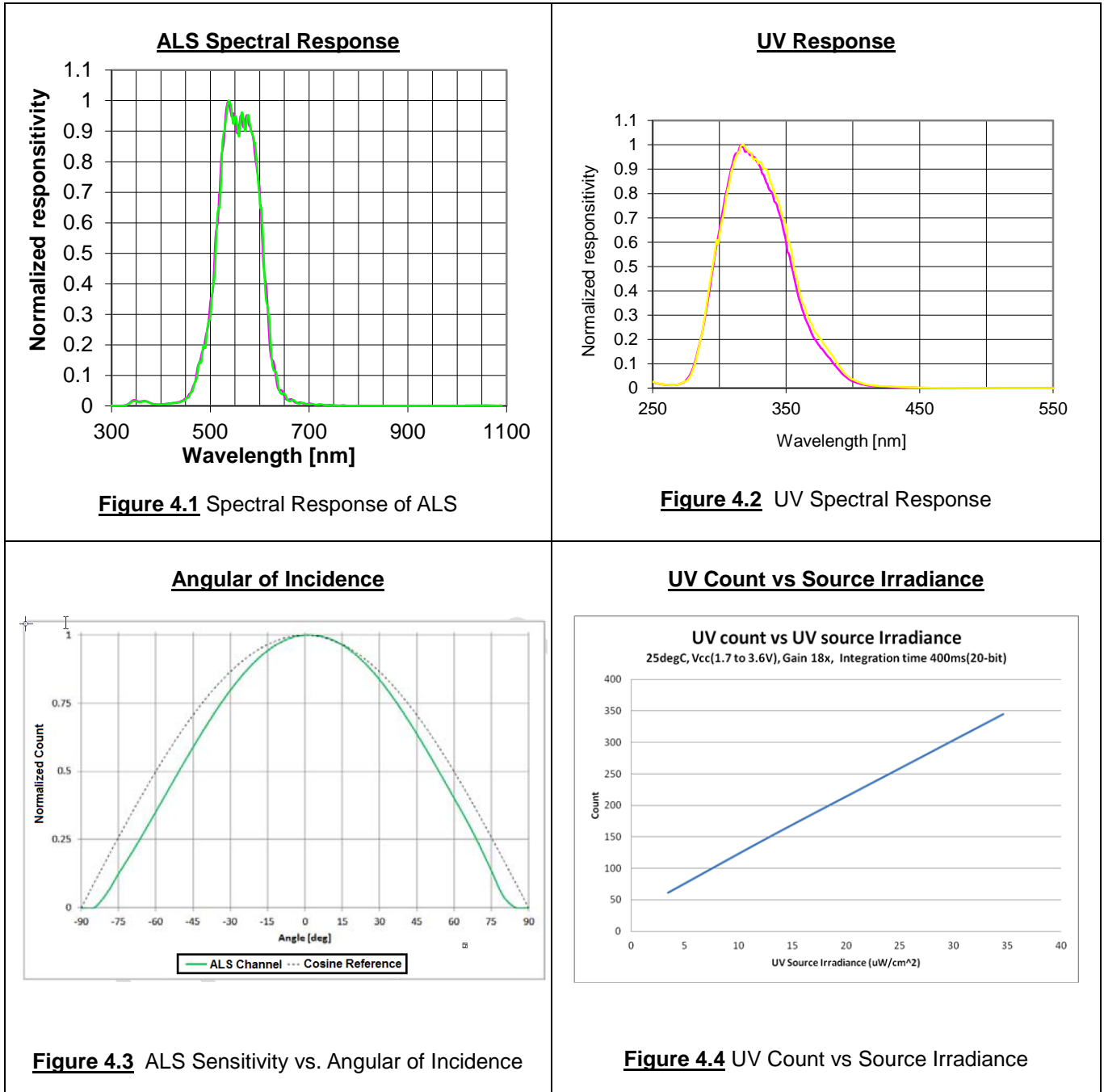



**OPTICAL SENSOR  
LTR-390UV-01**

**UV Count vs Gain**

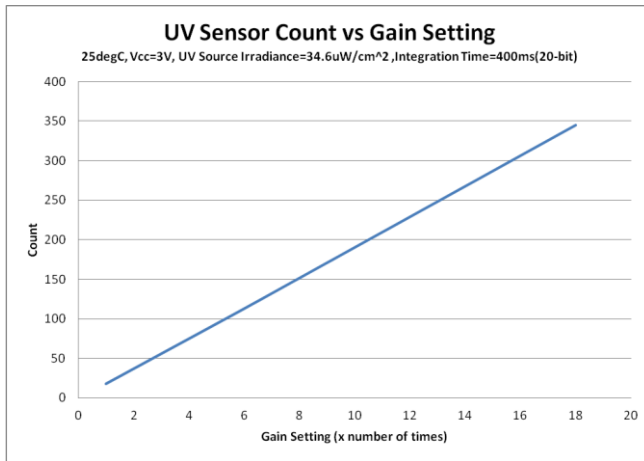

**Figure 4.5** UV Count vs Gain

**Sensor UVI vs Ref UVI  
(Gain 18x, 20-Bit, Sensitivity=2300 counts/UVI)**

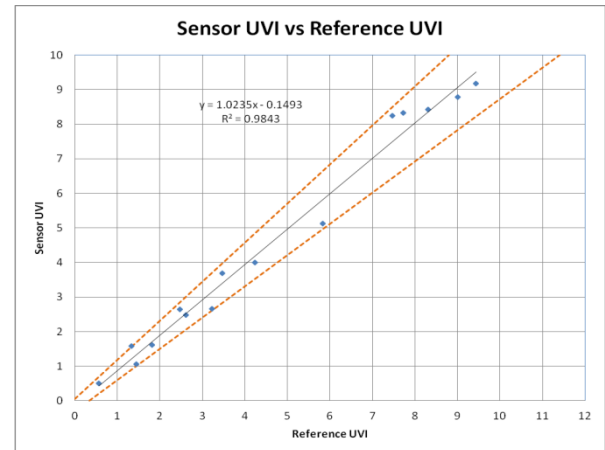

**Figure 4.6** Sensor UVI vs Reference UVI  
(Reference meter UVMICROLOG by sglux)

## OPTICAL SENSOR LTR-390UV-01

### 4.8. AC Electrical Characteristics

All specifications are at VBus = 1.7V, T<sub>ope</sub> = 25°C, unless otherwise noted.

Parameter	Symbol	Standard (Min)	Fast (Min)	Unit
SCL clock frequency	$f_{SCL}$	100	400	KHz
Bus free time between a STOP and START condition	$t_{BUF}$	4.7		us
Hold time (repeated) START condition. After this period, the first clock pulse is generated	$t_{HD;STA}$	4		us
LOW period of the SCL clock	$t_{LOW}$	4.7		us
HIGH period of the SCL clock	$t_{HIGH}$	4		us
Set-up time for a repeated START condition	$t_{SU;STA}$	4.7		us
Set-up time for STOP condition	$t_{SU;STO}$	4		us
Rise time of both SDA and SCL signals	$t_r$	30	300	ns
Fall time of both SDA and SCL signals	$t_f$	30	300	ns
Data hold time	$t_{HD;DAT}$	0		us
Data setup time	$t_{SU;DAT}$	100	100	ns
Pulse width of spikes which must be suppressed by the input filter	$t_{SP}$	0	50	ns

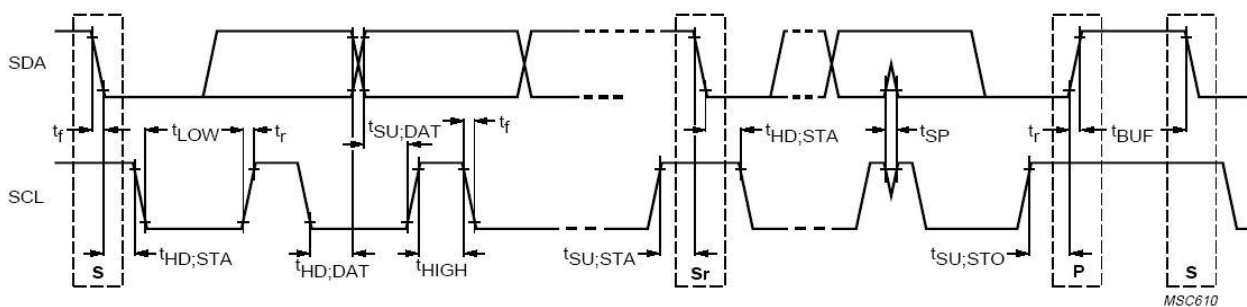

Definition of timing for I<sup>2</sup>C bus

**OPTICAL SENSOR  
LTR-390UV-01**

**5. Principle of Operation**

**5.1 I2C Protocol**

**I. I2C Write Protocol**

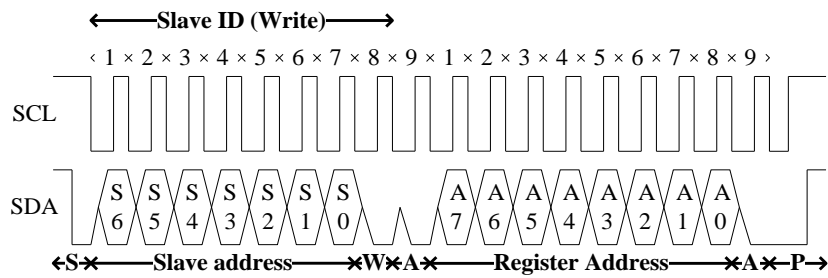
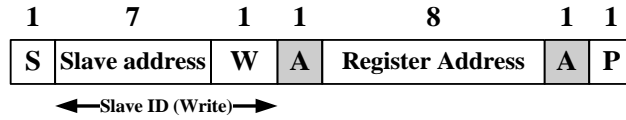

**II. I2C Write (Block Write) Protocol**

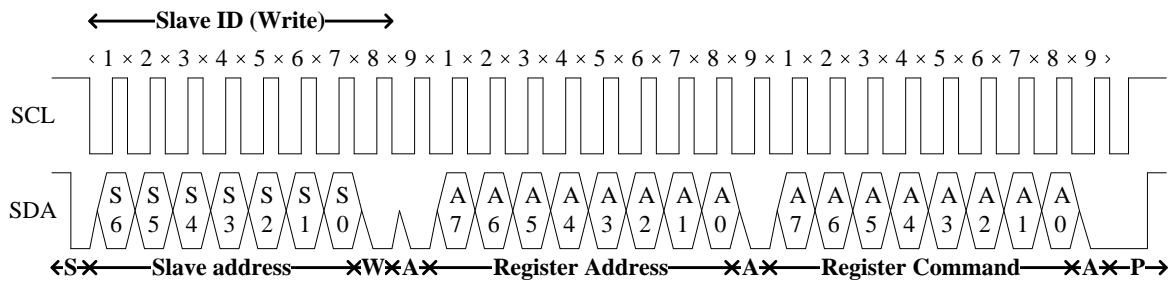
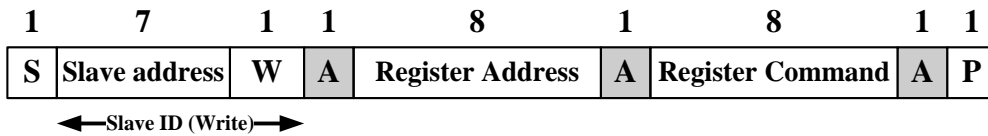

## OPTICAL SENSOR LTR-390UV-01

### III. I2C Read Protocol

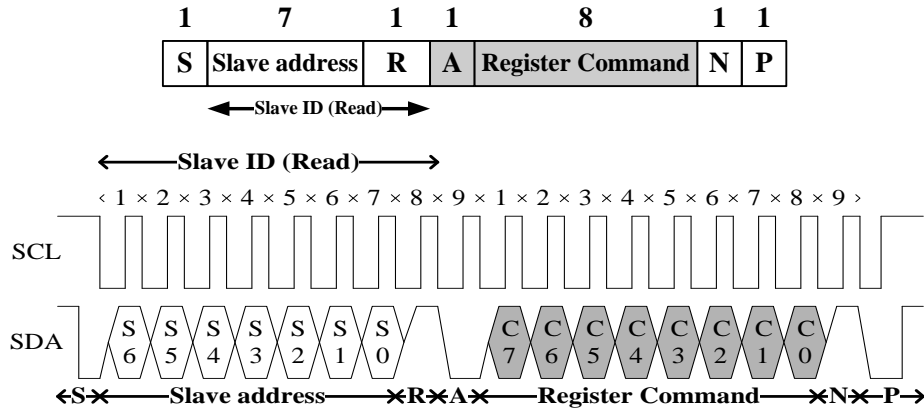

### IV. I2C Read (Block Read) Protocol

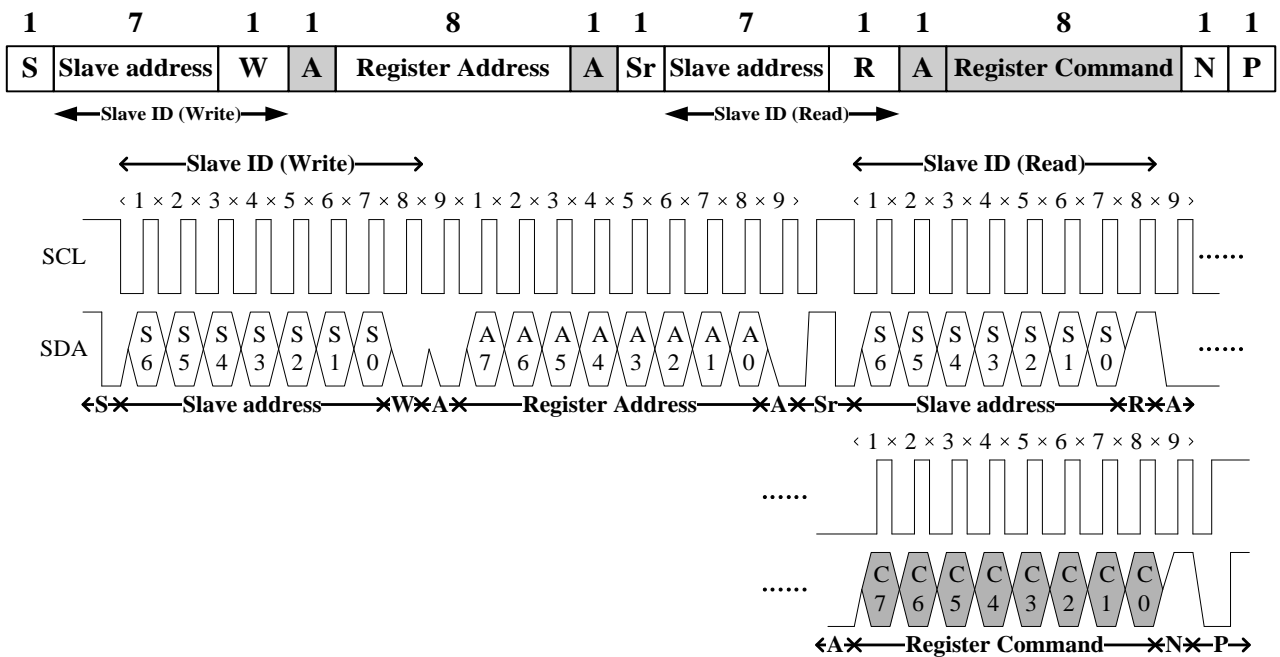

**A** Acknowledge (0 for an ACK)  
**S** Start condition  
**P** Stop condition  
**W** Write (0 for writing)  
 [Grey Box] Slave-to-master

**N** Non-Acknowledge (1 for an NACK)  
**Sr** Repeated Start condition  
**R** Read (1 for read)  
 [White Box] Master-to-Slave

## OPTICAL SENSOR LTR-390UV-01

### V. I2C Slave Address

The device has a 7-bit slave address of 0x53. A read/write bit should be appended to the slave address by the master device to properly communicate with the device.

I <sup>2</sup> C Slave Address (Default)									
Command Type	(0x53)							W/R	value
	Bit 7	Bit 6	Bit 5	Bit 4	Bit 3	Bit 2	Bit 1	Bit 0	
Write	1	0	1	0	0	1	1	0	0xA6
Read	1	0	1	0	0	1	1	1	0xA7

## OPTICAL SENSOR LTR-390UV-01

### 6. Register Set

Address	R / W	Register Name	Description	Reset Value
0x00	R/W	MAIN_CTRL	ALS/UVS operation mode control, SW reset	0x00
0x04	R/W	ALS_UVS_MEAS_RATE	ALS/UVS measurement rate and resolution in Active Mode	0x22
0x05	R/W	ALS_UVS_GAIN	ALS/UVS analog Gain range	0x01
0x06	R	PART_ID	Part number ID and revision ID	0xB2
0x07	R	MAIN_STATUS	Power-On status, Interrupt status, Data status	0x20
0x0D	R	ALS_DATA_0	ALS ADC measurement data, LSB	0x00
0x0E	R	ALS_DATA_1	ALS ADC measurement data	0x00
0x0F	R	ALS_DATA_2	ALS ADC measurement data, MSB	0x00
0x10	R	UVS_DATA_0	UVS ADC measurement data, LSB	0x00
0x11	R	UVS_DATA_1	UVS ADC measurement data	0x00
0x12	R	UVS_DATA_2	UVS ADC measurement data, MSB	0x00
0x13 – 0x18	R	Reserved	Reserved	0x00
0x19	R/W	INT_CFG	Interrupt configuration	0x10
0x1A	R/W	INT_PST	Interrupt persist setting	0x00
0x21	R/W	ALS_UVS_THRES_UP_0	ALS/UVS interrupt upper threshold, LSB	0xFF
0x22	R/W	ALS_UVS_THRES_UP_1	ALS/UVS interrupt upper threshold, intervening bits	0xFF
0x23	R/W	ALS_UVS_THRES_UP_2	ALS/UVS interrupt upper threshold, MSB	0x0F
0x24	R/W	ALS_UVS_THRES_LOW_0	ALS/UVS interrupt lower threshold, LSB	0x00
0x25	R/W	ALS_UVS_THRES_LOW_1	ALS/UVS interrupt lower threshold, intervening bits	0x00
0x26	R/W	ALS_UVS_THRES_LOW_2	ALS/UVS interrupt lower threshold, MSB	0x00

## OPTICAL SENSOR LTR-390UV-01

### 6.1 MAIN\_CTRL Register (Address: 0x00) (Read/Write)

This register controls the operation modes of UVS/ALS, which can be set to either standby or active mode. When writing to this register, it will cause a stop to any ongoing measurements ALS/UVS and start new measurement.

0x00	MAIN_CTRL (default = 0x00)							
	Bit 7	Bit 6	Bit 5	Bit 4	Bit 3	Bit 2	Bit 1	Bit 0
	<i>Reserved</i>			<i>Software Reset</i>	<i>UVS_Mode</i>	<i>0</i>	<i>ALS/UVS Enable</i>	<i>0</i>

Field	Bits	Default	Description	
Reserved	7:5	000	--	--
SW Reset	4	0	0	Software reset is NOT triggered (default)
			1	Software reset is triggered
UVS_Mode	3	0	0	ALS Mode
			1	UVS Mode
Reserved	2	0	--	Reserved
ALS/UVS Enable	1	0	0	Light sensor (ALS/ or UVS) standby
			1	Light sensor (ALS/ or UVS) active
Reserved	0	0	0	Write as '0'

## OPTICAL SENSOR LTR-390UV-01

### 6.2 ALS\_UVS\_MEAS\_RATE Register (Address: 0x04) (Read/Write)

This register controls ALS/UVS measurement resolution, Gain setting and measurement rate. When the measurement rate is programmed to be faster than possible for the programmed ADC measurement, the rate will be lowered than programmed (maximum speed).

0x04	ALS_UVS_MEAS_RATE (default = 0x22)							
	Bit 7	Bit 6	Bit 5	Bit 4	Bit 3	Bit 2	Bit 1	Bit 0
	0	ALS/UVS Resolution			0	ALS/UVS Measurement Rate		

Field	Bits	Default	Description	
Reserved	7	0	--	--
ALS/UVS Resolution	6:4	010	000	20 Bit, Conversion time = 400ms
			001	19 Bit, Conversion time = 200ms
			010	18 Bit, Conversion time = 100ms(default)
			011	17 Bit, Conversion time = 50ms
			100	16 Bit, Conversion time = 25ms
			101	13 Bit, Conversion time = 12.5ms
			110/111	Reserved
Reserved	3	0	--	Reserved
ALS/UVS Measurement Rate	2:0	010	000	25ms
			001	50ms
			010	100ms (default)
			011	200ms
			100	500ms
			101	1000ms
			110/111	2000ms



## OPTICAL SENSOR LTR-390UV-01

### 6.3 ALS\_UVS\_GAIN (Address: 0x05) (Read/Write)

This register controls ALS/UVS measurement Gain Range.

0x05	ALS_UVS_GAIN (default = 0x01)							
	Bit 7	Bit 6	Bit 5	Bit 4	Bit 3	Bit 2	Bit 1	Bit 0
	<i>Reserved</i>					<i>ALS/UVS Gain Range</i>		

Field	Bits	Default	Description	
Reserved	7:3	00000	--	Reserved
ALS/UVS Gain Range	2:0	001	000	Gain Range: 1
			001	Gain Range: 3 (default)
			010	Gain Range: 6
			011	Gain Range: 9
			100	Gain Range: 18

### 6.4 PART\_ID Register (Address: 0x06) (Read Only)

This register defines the part number and revision identification of the sensor.

0x06	PART_ID (default = 0xB2)							
	Bit 7	Bit 6	Bit 5	Bit 4	Bit 3	Bit 2	Bit 1	Bit 0
	<i>Part Number ID</i>				<i>Revision ID</i>			

Field	Bits	Default	Description
Part Number ID	7:4	1011	Part Number ID
Revision ID	3:0	0010	Revision ID of the component. The value increases by one each time a new silicon revision is manufactured.

## OPTICAL SENSOR LTR-390UV-01

### 6.5 MAIN\_STATUS Register (Address: 0x07) (Read Only)

This register stores the information about the ALS/UVS interrupts and data status. The interrupt status in Bit 4 determines if the ALS/UVS interrupt criteria are met in Normal Interrupt Mode. It triggers when the UVS/ALS data is above the upper or below the lower threshold for a specified number of consecutive measurements in respective interrupt persist settings.

0x07	MAIN_STATUS (default = 0x20)							
	Bit 7	Bit 6	Bit 5	Bit 4	Bit 3	Bit 2	Bit 1	Bit 0
	Reserved		Power-On status	ALS/UVS Interrupt status	ALS/UVS data status	Reserved		

Field	Bits	Default	Description	
Reserved	7:6	00	--	
Power-On Status	5	1	1	Power on event and all interrupt threshold settings in the registers have been reset to power on default states and should be examined if necessary.
			0	This flag is cleared after the register is read.
ALS/UVS Interrupt Status	4	0	0	Interrupt is NOT triggered (default)
			1	Interrupt is triggered and will be cleared after read
UVS/ALS Data Status	3	0	0	UVS/ALS data is old data (Data has been read)
			1	UVS/ALS data is new data (Data has not been read and will be cleared after read)
Reserved	2:0	000	---	

## OPTICAL SENSOR LTR-390UV-01

### 6.6 ALS\_DATA Registers (Address: 0x0D/ 0x0E/0x0F) (Read Only)

The Ambient Light Sensor Channel digital output data are expressed as a 13 to 20 bit unsigned integer data. When I<sup>2</sup>C read operation is active and points to any of the register address between 0x07 and 0x12, all 3 registers will be locked until the I<sup>2</sup>C read operation has been completed or the specified address range is left. This is to ensure that the data in the registers is from the same measurement even if an additional measurement cycle ends during the read operation. New measurement data is stored into temporary registers and the actual ALS\_DATA registers will be updated as soon as there is no on-going I<sup>2</sup>C read operation to the address range 0x07 to 0x12.

0x0D	ALS_DATA_0 (default = 0x00)							
	Bit 7	Bit 6	Bit 5	Bit 4	Bit 3	Bit 2	Bit 1	Bit 0
	<i>ALS_DATA_0, Low</i>							

0x0E	ALS_DATA_1 (default = 0x00)							
	Bit 7	Bit 6	Bit 5	Bit 4	Bit 3	Bit 2	Bit 1	Bit 0
	<i>ALS_DATA_1, Middle</i>							

0x0F	ALS_DATA_2 (default = 0x00)							
	Bit 7	Bit 6	Bit 5	Bit 4	Bit 3	Bit 2	Bit 1	Bit 0
	<i>Reserved</i>				<i>ALS_DATA_2, High</i>			

Field	Address	Bits	Default	Description
ALS_Data_0, Low	0x0D	7:0	00000000	ALS Data lower byte data
ALS_Data_1, Middle	0x0E	7:0	00000000	ALS Data Middle byte data
ALS_Data_2, High	0x0F	7:4	0000	Reserved
		3:0	0000	ALS Data Higher byte data

## OPTICAL SENSOR LTR-390UV-01

### 6.7 UVS\_DATA Registers (Address: 0x10/0x11/0x12) (Read Only)

The UV Sensor Channel digital output data are expressed as a 16 to 20 bit unsigned integer data. When I<sup>2</sup>C read operation is active and points to any of the register address between 0x07 and 0x12, all 3 registers will be locked until the I<sup>2</sup>C read operation has been completed or the specified address range is left. This is to ensure that the data in the registers is from the same measurement even if an additional measurement cycle ends during the read operation. New measurement data is stored into temporary registers and the UV Sensor registers will be updated as soon as there is no on-going I<sup>2</sup>C read operation to the address range 0x07 to 0x12.

0x10	UVS_DATA_0 (default = 0x00)							
	Bit 7	Bit 6	Bit 5	Bit 4	Bit 3	Bit 2	Bit 1	Bit 0
	<i>UVS_Data_0, Low Byte Data</i>							
0x11	UVS_DATA_1 (default = 0x00)							
	Bit 7	Bit 6	Bit 5	Bit 4	Bit 3	Bit 2	Bit 1	Bit 0
	<i>UVS_Data_1, Middle Byte Data</i>							
0x12	UVS_DATA_2 (default = 0x00)							
	Bit 7	Bit 6	Bit 5	Bit 4	Bit 3	Bit 2	Bit 1	Bit 0
	<i>Reserved</i>				<i>UVS_Data_2, Higher Byte Data</i>			

Field	Address	Bits	Default	Description
UVS_Data_0	0x10	7:0	00000000	UVS Data lower byte data
UVS_Data_1	0x11	7:0	00000000	UVS Data Middle byte data
UVS_Data_2	0x12	7:4	0000	Reserved
		3:0	0000	UVS Data Higher byte data

## OPTICAL SENSOR LTR-390UV-01

### 6.8 INT\_CFG Register (Address: 0x19) (Read/Write)

This register controls the operation of the interrupt pin and functions. The ALS/UVS interrupt is enabled by LS\_INT\_EN=1 (Bit 2). The ALS/UVS interrupt source generator either uses the ALS\_DATA or the UVS\_DATA registers as input. The ALS/UVS interrupt source is selected by the LS\_INT\_SEL bits in the INT\_CFG register

0x19	INT_CFG (default = 0x10)							
	Bit 7	Bit 6	Bit 5	Bit 4	Bit 3	Bit 2	Bit 1	Bit 0
	Reserved		LS_INT_SEL		Reserved	LS_INT_EN	Reserved	

Field	Bits	Default	Description	
Reserved	7:6	00	--	--
LS Interrupt Selection	5:4	01	00	Reserved
			01	ALS Channel (Default)
			10	Reserved
			11	UVS Channel
Reserved	3	0	--	--
LS interrupt enable	2	0	0	LS interrupt disabled (default)
			1	LS interrupt enabled
Reserved	1:0	00	Write as '00'	

## OPTICAL SENSOR LTR-390UV-01

### 6.9 INT\_PST Register (Address: 0x1A) (Read/Write)

This register INT\_PST (Interrupt Persist) sets the ALS/UV persist level. Persist is the N number of times the measurement data is outside the range defined by the upper and lower threshold limits before asserting the interrupt.

0x1A	INT Persist (default = 0x00)							
	Bit 7	Bit 6	Bit 5	Bit 4	Bit 3	Bit 2	Bit 1	Bit 0
	<i>ALS/UV_Persist</i>				<i>Reserved</i>			

Field	Bits	Default	Description	
ALS/UV Persist	7:4	0000	0000	Every ALS/UV value out of threshold range asserts an interrupt (default)
			0001	2 consecutive ALS/UV values out of threshold range assert an interrupt
			...	...
			1111	16 consecutive ALS/UV values out of threshold range assert an interrupt
Reserved	3:0	0000	...	

### 6.10 UVS\_ALS\_THRES Registers (Address: 0x21/0x22/0x23/0x24/0x25/0x26) (Read/Write)

The UVS/ALS\_THRES\_UP (up to 20-bits) and UVS/ALS\_THRES\_LOW (up to 20-bits) registers determines the upper and lower limit of the interrupt threshold value respectively. Interrupt will be triggered if measurement data in DATA\_x registers is exceeding the upper and lower limits.

0x21	UVS/ALS_THRES_UP_0 (default = 0xFF)							
	Bit 7	Bit 6	Bit 5	Bit 4	Bit 3	Bit 2	Bit 1	Bit 0
	<i>UVS/ALS Upper Threshold, Low</i>							
0x22	UVS/ALS_THRES_UP_1 (default = 0xFF)							
	Bit 7	Bit 6	Bit 5	Bit 4	Bit 3	Bit 2	Bit 1	Bit 0
	<i>UVS/ALS Upper Threshold, Middle</i>							
0x23	UVS/ALS_THRES_UP_2 (default = 0x0F)							
	Bit 7	Bit 6	Bit 5	Bit 4	Bit 3	Bit 2	Bit 1	Bit 0
	<i>Reserved</i>				<i>UVS/ALS Upper Threshold, Higher</i>			

## OPTICAL SENSOR LTR-390UV-01

0x24	UVS/ALS_THRES_LOW_0 (default = 0x00)							
	Bit 7	Bit 6	Bit 5	Bit 4	Bit 3	Bit 2	Bit 1	Bit 0
	<i>UVS/ALS Low Threshold, Low</i>							
0x25	UVS/ALS_THRES_LOW_1 (default = 0x00)							
	Bit 7	Bit 6	Bit 5	Bit 4	Bit 3	Bit 2	Bit 1	Bit 0
	<i>UVS/ALS Low Threshold, Middle</i>							
0x26	UVS/ALS_THRES_LOW_2 (default = 0x00)							
	Bit 7	Bit 6	Bit 5	Bit 4	Bit 3	Bit 2	Bit 1	Bit 0
	<i>Reserved</i>				<i>UVS/ALS Low Threshold, Higher</i>			

Field	Address	Bits	Default	Description
UVS/ALS Upper Threshold, Low	0x21	7:0	11111111	CS/ALS upper interrupt threshold, Low byte
UVS/ALS Upper Threshold, Mid	0x22	7:0	11111111	CS/ALS upper interrupt threshold, Mid byte
UVS/ALS Upper Threshold, Higher	0x23	7:4	0000	Reserved
		3:0	1111	UVS/ALS upper interrupt threshold, Higher byte
UVS/ALS Lower Threshold, Low	0x24	7:0	00000000	UVS/ALS lower interrupt threshold, Low byte
UVS/ALS Lower Threshold, Mid	0x25	7:0	00000000	UVS/ALS lower interrupt threshold, Mid byte
UVS/ALS Lower Threshold, Higher	0x26	7:4	0000	Reserved
		3:0	0000	UVS/ALS lower interrupt threshold, Higher byte

**OPTICAL SENSOR  
LTR-390UV-01**

**7. ALS/UVI Formula**

**7.1 ALS Lux Formula**

Lux\_Calc is the calculated lux reading based on the output ADC from ALS DATA regardless of light sources.

$$Lux_{calc} = \frac{0.6 \times ALS\_DATA}{(GAIN \times INT)} \times W_{FAC}$$

Where :

1. ALS\_DATA = Data stored in the registers (Address: 0x0D-0x0F)
2. For device under tinted window with coated-ink of flat transmission rate at 400-600nm wavelength, window factor is to compensate light loss due to the lower transmission rate from the coated-ink.
  - a. WFAC = 1 for NO window / clear window glass.
  - b. WFAC >1 device under tinted window glass. Calibrate under white LED.
3. The Gain factors & Integration time factors:

ALS Gain	GAIN
X1	<b>1</b>
X3	<b>3</b>
X6	<b>6</b>
X9	<b>9</b>
X18	<b>18</b>

Resolution (bit) / Integration Time (ms)	INT
16-bit, 25ms	<b>0.25</b>
17-bit, 50ms	<b>0.5</b>
18-bit, 100ms	<b>1</b>
19-bit, 200ms	<b>2</b>
20-bit, 400ms	<b>4</b>

**7.2 UVI Conversion Formula**

$$UVI_{Calc} = \frac{UV\ Sensor\ Count}{UV\ Sensitivity} \times W_{FAC}$$

where:

1. WFAC depends on the type of window used. WFAC =1 (no window )



# OPTICAL SENSOR LTR-390UV-01

## 8. Device Operation (State Machine and Interrupt Features)

### 8.1 State Machine

Below diagram is the main state machine of LTR-390UV.

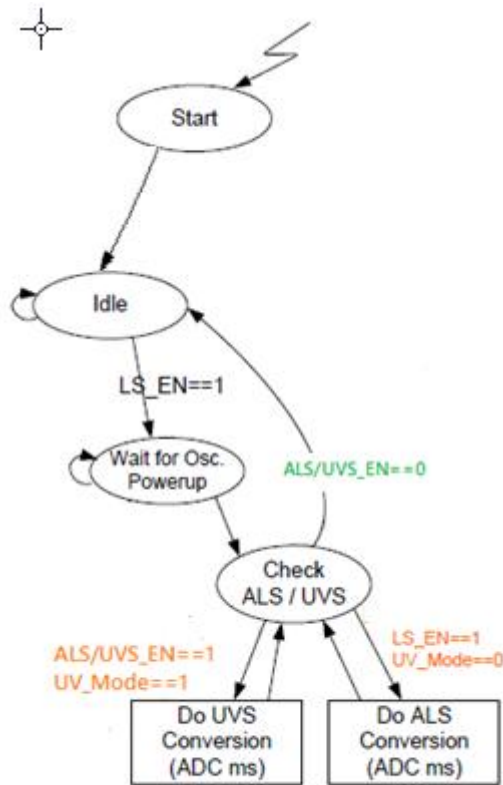

ALS measurements can be activated by setting the UVS/ALS\_Enable bit to 1 and the UVS\_Mode bit to 0 in the MAIN\_CTRL register. UV measurements can be activated by setting the LS\_EN bit to 1 and the UVS\_Mode bit to 1 in the MAIN\_CTRL register. As soon as ALS or UVS become activated through an I<sup>2</sup>C™ command, the internal support blocks are powered on. Once the voltages and currents are settled (typically after 5ms), the state machine checks for trigger events from a measurement scheduler to start the ALS or UVS conversions according to the selected measurement repeat rates. Once LS\_EN is changed back to 0, a conversion running on the respective channel will be completed and the relevant ADCs and support blocks will move to standby mode.

## OPTICAL SENSOR LTR-390UV-01

### 8.2 Interrupt Features

This device generates Light Sensor (ALS or UVS depending on configuration) interrupt signals and output to the INT pad. The interrupt conditions are always evaluated after completion of a new conversion on the ALS/UV channels.

#### 8.2.1 ALS/UVS Sensor Interrupt

The LS interrupt is enabled by LS\_INT\_EN=1. The ALS/UVS interrupt source generator either uses the ALS\_DATA or the UVS\_DATA registers as input. The ALS/UVS interrupt source is selected by the ALS/UVS\_INT\_SEL bits in the INT\_CFG register. The Light Sensor threshold interrupt is enabled with ALS/UVS\_INT\_EN=1. It is set when the ALS\_DATA or UVS\_DATA data is above the upper or below the lower threshold for a specified number of consecutive measurements. It is set when the absolute value of the difference between the previous and current ALS/UVS data is above the decoded ALS/UVS variance threshold for a specified number of consecutive measurements (1+ALS/UVS\_PERSIST).

## OPTICAL SENSOR LTR-390UV-01

### 9. Pseudo Codes Examples

#### SLAVE Addresses

```
Slave_Addr = 0x53 // Slave address
```

#### MAIN\_CTRL Register

```
// This defines the operating modes of the ALS,UV. Default setting is 0x00 in Standby mode.
```

```
Register_Addr = 0x00 //MAIN_CTRL register
Command = 0x02 // ALS in Active Mode
// UVS in Active Mode, Command = 0x0A
```

```
WriteByte(Slave_Addr, Register_Addr, Command);
```

#### ALS\_UVS\_MEAS\_RATE Register

```
// This controls the ALS/UVS Resolution & Measurement rate.
// Default setting of the register is 0x22
```

```
Register_Addr = 0x04 // ALS_UVS_MEAS_RATE register
Command = 0x22 // Resolution=18bits, Meas Rate = 100ms
// Resolution=20bits, Meas Rate = 500ms, Command=0x04
```

```
WriteByte(Slave_Addr, Register_Addr, Command)
```

#### ALS\_UVS\_GAIN Register

```
// This controls the ALS/UVS GAIN.
// Default setting of the register is 0x01
```

```
Register_Addr = 0x05 // ALS_UVS_GAIN register
Command = 0x01 // Gain Range=3.
// Gain Range=18, Command=0x04
```

```
WriteByte(Slave_Addr, Register_Addr, Command)
```

#### INT\_CFG Register

```
// This controls the interrupt mode of ALS, UVS.
// Default setting of the register is 0x10
```

```
Register_Addr = 0x19 // INT_CFG register
Command = 0x14 // ALS_INT_EN=1.
// UVS_INT_EN=1, Command=0x34
```

```
WriteByte(Slave_Addr, Register_Addr, Command)
```

#### INT\_PST Register

```
// This controls the persistence of interrupt of ALS, UVS.
// Default setting of the register is 0x00
```

```
Register_Addr = 0x1A // INT_CFG register
Command = 0x00 // ALS/UVS Persist=0.
// ALS/UVS Persist=1, Command=0x10
```

```
WriteByte(Slave_Addr, Register_Addr, Command)
```

## OPTICAL SENSOR LTR-390UV-01

### ALS\_DATA Registers (Read Only)

//The registers 0x0D, 0x0E & 0x0F contain ALS data, up to 20bits.

```
Register_Addr = 0x0D // ALS_DATA_0 address
Data1 = ReadByte(Slave_Addr, Register_Addr)
Register_Addr = 0x0E // ALS_DATA_1 address
Data2 = ReadByte(Slave_Addr, Register_Addr)
Register_Addr = 0x0F // ALS_DATA_2 address
Data3 = ReadByte(Slave_Addr, Register_Addr) // ALS_DATA=Data3*65536+Data2*256+Data1.
```

### UVS\_DATA Registers (Read Only)

//The registers 0x10, 0x11 & 0x12 contain UVS data, up to 20bits.

```
Register_Addr = 0x10 // UVS_DATA_0 address
Data1 = ReadByte(Slave_Addr, Register_Addr)
Register_Addr = 0x11 // UVS_DATA_1 address
Data2 = ReadByte(Slave_Addr, Register_Addr)
Register_Addr = 0x12 // UVS_DATA_2 address
Data3 = ReadByte(Slave_Addr, Register_Addr) // UVS_DATA=Data3*65536+Data2*256+Data1.
```

**OPTICAL SENSOR  
LTR-390UV-01**

**10. Recommended Leadfree Reflow Profile**

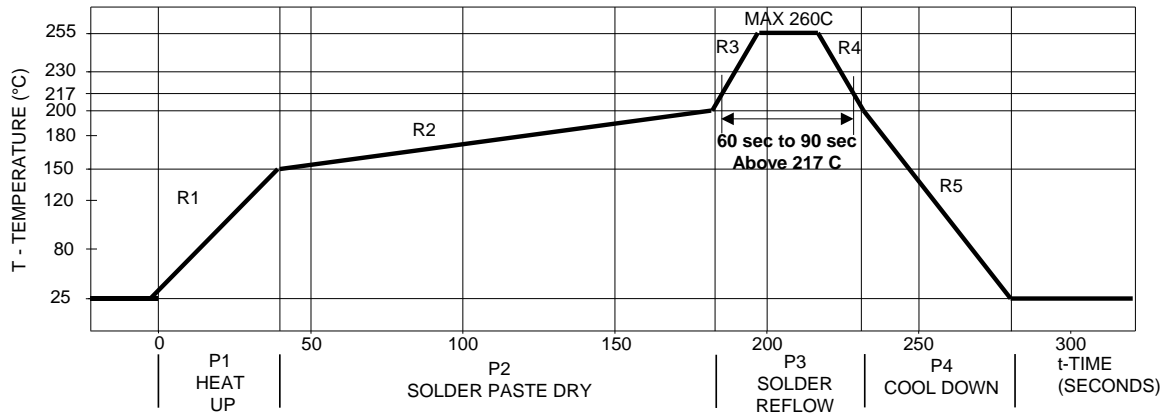

Process Zone	Symbol	$\Delta T$	Maximum $\Delta T/\Delta time$ or Duration
Heat Up	P1, R1	25°C to 150°C	3°C/s
Solder Paste Dry	P2, R2	150°C to 200°C	100s to 180s
Solder Reflow	P3, R3	200°C to 260°C	3°C/s
	P3, R4	260°C to 200°C	-6°C/s
Cool Down	P4, R5	200°C to 25°C	-6°C/s
Time maintained above liquid's point , 217°C		> 217°C	60s to 90s
Peak Temperature		260°C	-
Time within 5°C of actual Peak Temperature		> 255°C	20s
Time 25°C to Peak Temperature		25°C to 260°C	8mins

It is recommended to perform reflow soldering no more than twice.

**OPTICAL SENSOR  
LTR-390UV-01**

**11. Moisture Proof Packaging**

All LTR-390UV-01 are shipped in moisture proof package. Once opened, moisture absorption begins. This part is compliant to JEDEC J-STD-033A Level 3.

**Time from Unsealing to Soldering**

After removal from the moisture barrier bag, the parts should be stored at the recommended storage conditions and soldered within seven days. When the moisture barrier bag is opened and the parts are exposed to the recommended storage conditions for more than seven days, the parts must be baked before reflow to prevent damage to the parts.

**1. Recommended Storage Conditions**

<b>Storage Temperature</b>	10°C to 30°C
<b>Relative Humidity</b>	Below 60% RH

**2. Baking Conditions**

<b>Package</b>	<b>Temperature</b>	<b>Time</b>
In Reels	60°C	48 hours
In Bulk	100°C	4 hours

Baking should only be done once.

**OPTICAL SENSOR  
LTR-390UV-01**

**12. Recommended Land Pattern**

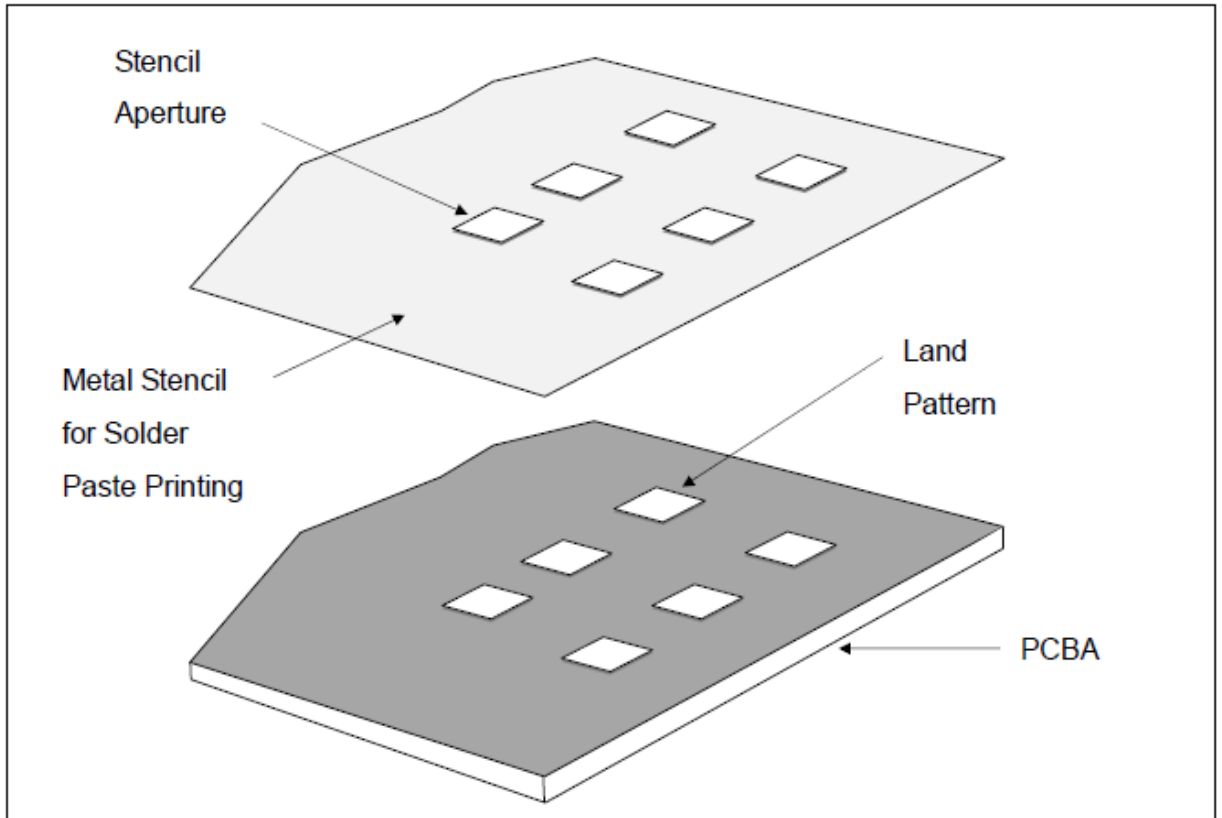

**I. Recommended Land Pattern for LTR-390UV-01**

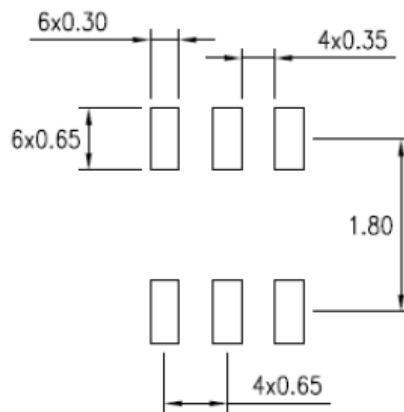

Note: All dimensions are in millimeters

## OPTICAL SENSOR LTR-390UV-01

### 13. Metal Stencil Aperture

It is recommended that the metal stencil used for solder paste printing has a thickness ( $t$ ) of 0.11mm (0.004 inches / 4 mils) or 0.127mm (0.005 inches / 5 mils).

The stencil aperture opening is recommended to be 0.3mm x 0.65mm which has the same dimension as the land pattern. This is to ensure adequate printed solder paste volume and yet no shorting.

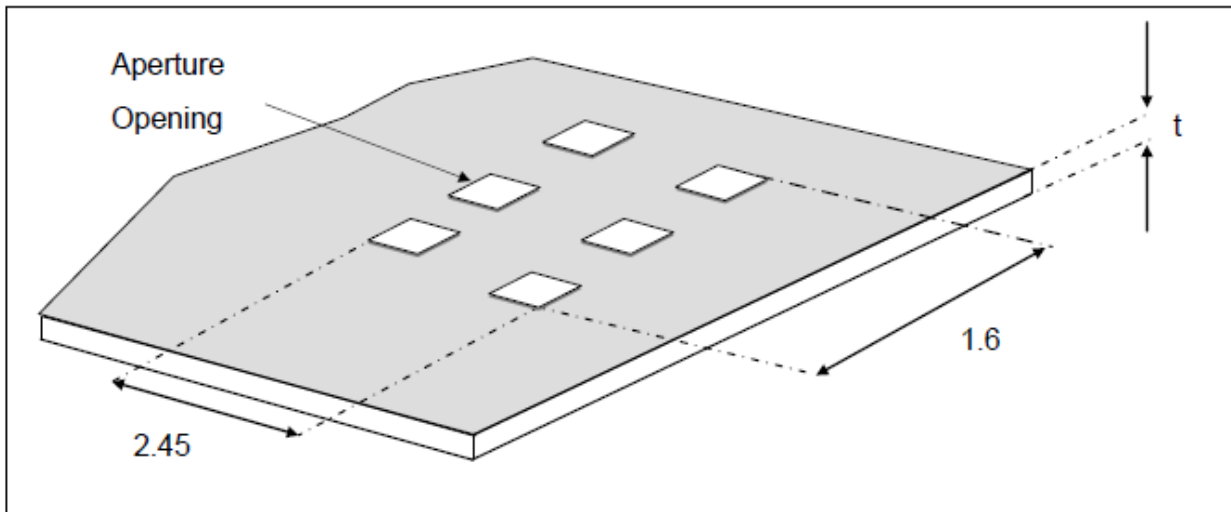

Note:

1. All dimensions are in millimeters



**OPTICAL SENSOR  
LTR-390UV-01**

**14. Tape and Reel Dimensions**

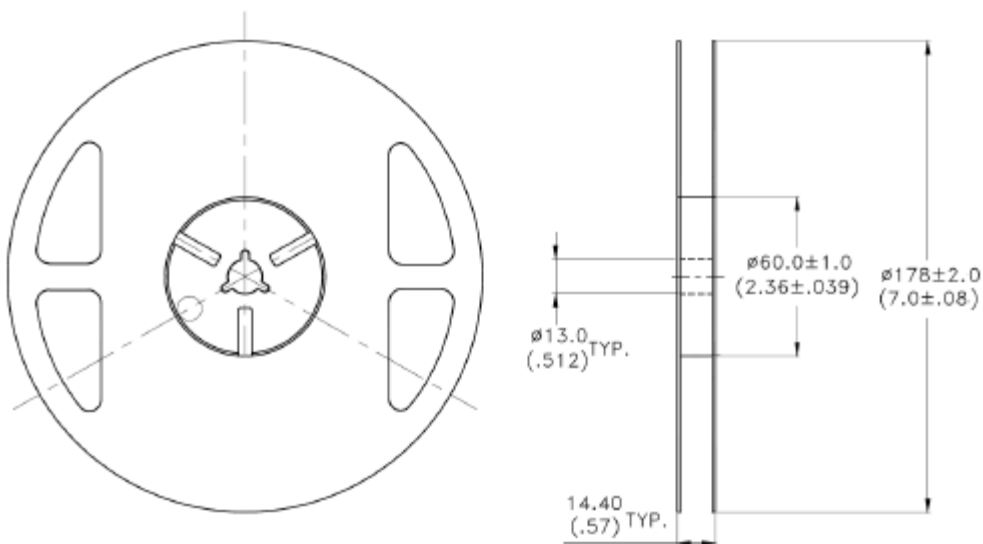
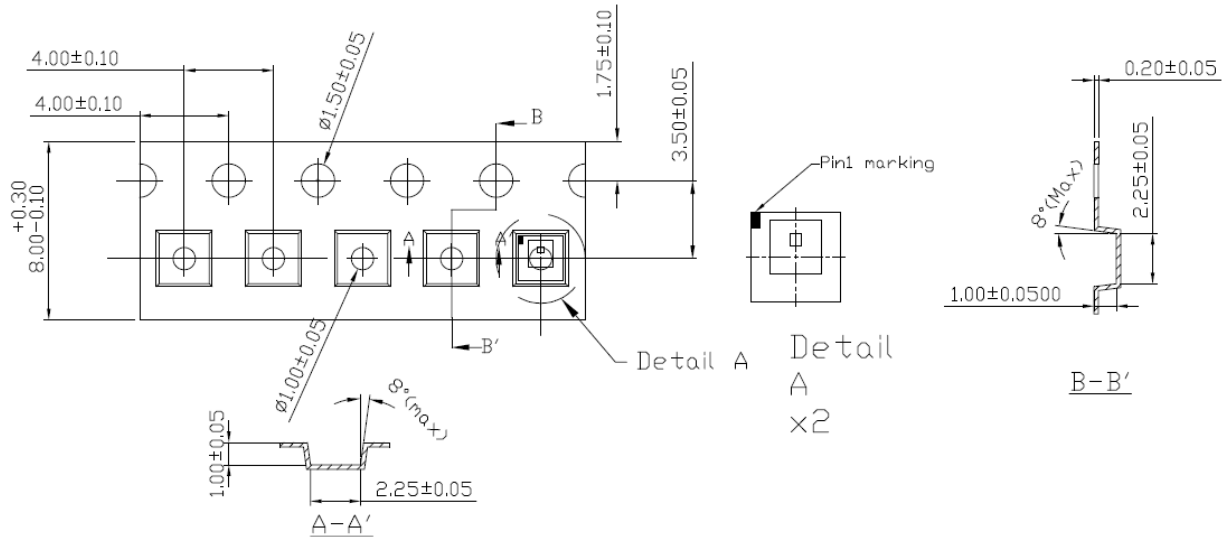

Notes:

1. All dimensions are in millimeters (inches)
2. Empty component pockets sealed with top cover tape
3. 7 inch reel - 2500 pieces per reel
4. In accordance with ANSI/EIA 481-1-A-1994 specifications

## OPTICAL SENSOR LTR-390UV-01

### Revision Table:

Version	Update	Page	Date
1.0	Datasheet as created	Total 30	28-Jul-15
1.1	ALS lux formula updated	Total 33	24-Aug-15

# Mouser Electronics

Authorized Distributor

Click to View Pricing, Inventory, Delivery & Lifecycle Information:

[Lite-On:](#)

[LTR-390UV-01](#)

Компания «Life Electronics» занимается поставками электронных компонентов импортного и отечественного производства от производителей и со складов крупных дистрибьюторов Европы, Америки и Азии.

С конца 2013 года компания активно расширяет линейку поставок компонентов по направлению коаксиальный кабель, кварцевые генераторы и конденсаторы (керамические, пленочные, электролитические), за счёт заключения дистрибьюторских договоров

Мы предлагаем:

- Конкурентоспособные цены и скидки постоянным клиентам.
- Специальные условия для постоянных клиентов.
- Подбор аналогов.
- Поставку компонентов в любых объемах, удовлетворяющих вашим потребностям.
- Приемлемые сроки поставки, возможна ускоренная поставка.
- Доставку товара в любую точку России и стран СНГ.
- Комплексную поставку.
- Работу по проектам и поставку образцов.
- Формирование склада под заказчика.
- Сертификаты соответствия на поставляемую продукцию (по желанию клиента).
- Тестирование поставляемой продукции.
- Поставку компонентов, требующих военную и космическую приемку.
- Входной контроль качества.
- Наличие сертификата ISO.

В составе нашей компании организован Конструкторский отдел, призванный помогать разработчикам, и инженерам.

Конструкторский отдел помогает осуществить:

- Регистрацию проекта у производителя компонентов.
- Техническую поддержку проекта.
- Защиту от снятия компонента с производства.
- Оценку стоимости проекта по компонентам.
- Изготовление тестовой платы монтаж и пусконаладочные работы.



Тел: +7 (812) 336 43 04 (многоканальный)

Email: [org@lifeelectronics.ru](mailto:org@lifeelectronics.ru)