

FEATURES

The HV series not only withstands high temperatures (200°C), but also offers high voltage (500-4000 VDC)

To be used in robust applications

- Down Hole
- Industrial
- Harsh Environments

NOTE:

Other tolerances, higher capacitance values, voltages, or special package configurations are available upon request.

CAPACITOR OUTLINE DRAWING

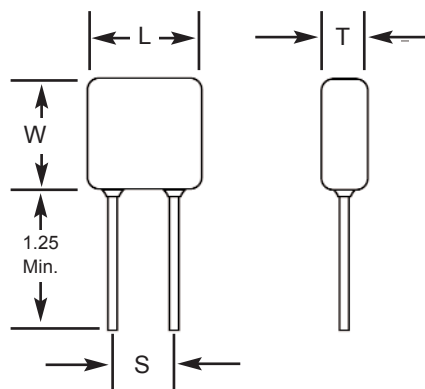

DIMENSIONS

Style	Sizes in Inches (mm) max.			Lead Spacing ±0.030 (S)
	Length (L)	Width (W)	Thickness (T)	
HV10	.250 (6.35)	.220 (5.59)	.150 (3.81)	.170 (4.32)
HV11	.320 (8.13)	.300 (7.62)	.250 (6.35)	.200 (5.08)
HV12	.420 (10.67)	.400 (10.16)	.250 (6.35)	.300 (7.62)
HV13	.520 (13.21)	.500 (12.70)	.300 (7.62)	.400 (10.16)
HV14	.620 (15.75)	.500 (12.70)	.300 (7.62)	.500 (12.70)
HV15	.720 (18.29)	.700 (17.78)	.300 (7.62)	.600 (15.24)
HV16	.820 (20.83)	.700 (17.78)	.350 (8.89)	.700 (17.78)

PART NUMBER AND ORDERING INFORMATION

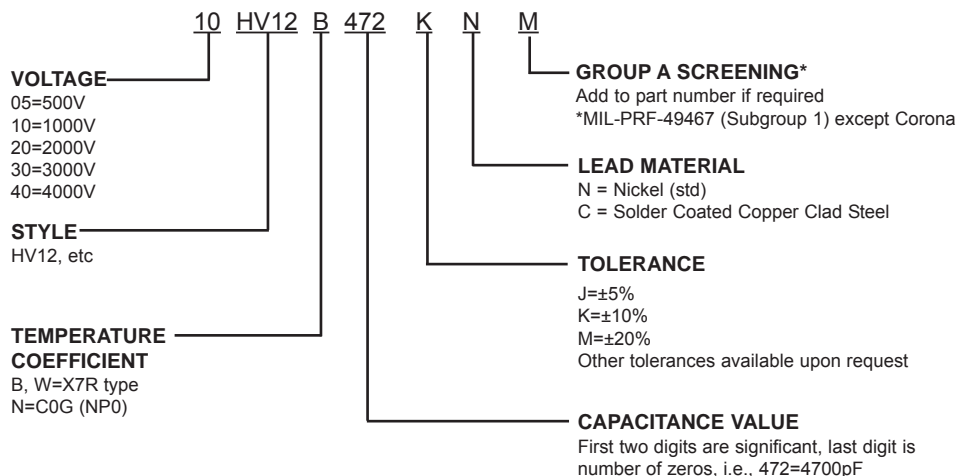

MARKING

(HV10, HV11)
472M
KEC
Date Code

(All other sizes)
HV12B472M
1kV
KEC
Date Code

High Temperature (+200°C), High Voltage Radial Ceramic Capacitors HV Series

COG DIELECTRIC

STYLE		HV10			HV11				HV12				HV13				HV14					HV15					HV16				
Cap	L MAX	.250 (6.35)			.320 (8.13)				.420 (10.67)				.520 (13.21)				.620 (15.75)					.720 (18.29)					.820 (20.83)				
	W MAX	.220 (5.59)			.300 (7.62)				.400 (10.16)				.500 (12.70)				.500 (12.70)					.700 (17.78)					.700 (17.78)				
	T MAX	.150 (3.81)			.250 (6.35)				.250 (6.35)				.300 (7.62)				.300 (7.62)					.300 (7.62)					.350 (8.89)				
	S ± .030	.170 (4.32)			.200 (5.08)				.300 (7.62)				.400 (10.16)				.500 (12.70)					.600 (15.24)					.700 (17.78)				
	Lead Dia. +0.004/-0.002	.025 (.635)			.025 (.635)				.025 (.635)				.025 (.635)				.025 (.635)					.025 (.635)					.025 (.635)				
	Cap Code	WVDC			WVDC				WVDC				WVDC				WVDC					WVDC					WVDC				
	500	1k	2k	500	1k	2k	3k	500	1k	2k	3k	500	1k	2k	3k	500	1k	2k	3k	4k	500	1k	2k	3k	4k	500	1k	2k	3k	4k	
12pF	120																														
15	150																														
18	180																														
22	220																														
27	270																														
33	330																														
39	390																														
47	470																														
56	560																														
68	680																														
82	820																														
100	101																														
120	121																														
150	151																														
180	181																														
220	221																														
270	271																														
330	331																														
390	391																														
470	471																														
560	561																														
680	681																														
820	821																														
1000	102																														
1200	122																														
1500	152																														
1800	182																														
2200	222																														
2700	272																														
3300	332																														
3900	392																														
4700	472																														
5600	562																														
6800	682																														
8200	822																														
0.01uF	103																														
0.012	123																														
0.015	153																														

X7R DIELECTRIC

STYLE		HV10			HV11			HV12			HV13				HV14				HV15				HV16					
Cap	L MAX	.250 (6.35)			.320 (8.13)			.420 (10.67)			.520 (13.21)				.620 (15.75)				.720 (18.29)				.820 (20.83)					
	W MAX	.220 (5.59)			.300 (7.62)			.400 (10.16)			.500 (12.70)				.500 (12.70)				.700 (17.78)				.700 (17.78)					
	T MAX	.150 (3.81)			.250 (6.35)			.250 (6.35)			.300 (7.62)				.300 (7.62)				.300 (7.62)				.350 (8.89)					
	S± .030	.170 (4.32)			.200 (5.08)			.300 (7.62)			.400 (10.16)				.500 (12.70)				.600 (15.24)				.700 (17.78)					
	Lead Dia. +0.004/-0.002	.025 (.635)			.025 (.635)			.025 (.635)			.025 (.635)				.025 (.635)				.025 (.635)				.025 (.635)					
	Cap Code	WVDC			WVDC			WVDC			WVDC				WVDC				WVDC				WVDC					
	500	1k	2k	500	1k	2k	500	1k	2k	500	1k	2k	3k	500	1k	2k	3k	4k	500	1k	2k	3k	4k	500	1k	2k	3k	4k
270pF	271																											
330	331																											
390	391																											
470	471																											
560	561																											
680	681																											
820	821																											
1000	102																											
1200	122																											
1500	152																											
1800	182																											
2200	222																											
2700	272																											
3300	332																											
3900	392																											
4700	472																											
5600	562																											
6800	682																											
8200	822																											
0.01uF	103																											
0.012	123																											
0.015	153																											
0.018	183																											
0.022	223																											
0.027	273																											
0.033	333																											
0.039	393																											
0.047	473																											
0.056	563																											
0.068	683																											
0.082	823																											
0.10	104																											
0.12	124																											
0.15	154																											
0.18	184																											
0.22	224																											
0.27	274																											
0.33	334																											
0.39	394																											
0.47	474																											

Компания «Life Electronics» занимается поставками электронных компонентов импортного и отечественного производства от производителей и со складов крупных дистрибьюторов Европы, Америки и Азии.

С конца 2013 года компания активно расширяет линейку поставок компонентов по направлению коаксиальный кабель, кварцевые генераторы и конденсаторы (керамические, пленочные, электролитические), за счёт заключения дистрибьюторских договоров

Мы предлагаем:

- Конкурентоспособные цены и скидки постоянным клиентам.
- Специальные условия для постоянных клиентов.
- Подбор аналогов.
- Поставку компонентов в любых объемах, удовлетворяющих вашим потребностям.
- Приемлемые сроки поставки, возможна ускоренная поставка.
- Доставку товара в любую точку России и стран СНГ.
- Комплексную поставку.
- Работу по проектам и поставку образцов.
- Формирование склада под заказчика.
- Сертификаты соответствия на поставляемую продукцию (по желанию клиента).
- Тестирование поставляемой продукции.
- Поставку компонентов, требующих военную и космическую приемку.
- Входной контроль качества.
- Наличие сертификата ISO.

В составе нашей компании организован Конструкторский отдел, призванный помогать разработчикам, и инженерам.

Конструкторский отдел помогает осуществить:

- Регистрацию проекта у производителя компонентов.
- Техническую поддержку проекта.
- Защиту от снятия компонента с производства.
- Оценку стоимости проекта по компонентам.
- Изготовление тестовой платы монтаж и пусконаладочные работы.



Тел: +7 (812) 336 43 04 (многоканальный)

Email: org@lifeelectronics.ru