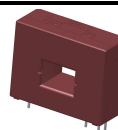

K-No.: 24959
100 A Current Sensor Module for 5V-Sply Voltage

 For electronic current measurement:
 DC, AC, pulsed, mixed ...,
 with a galvanic isolation between
 primary circuit (high power) and
 secondary circuit (electronic circuit)

Date: 07.04.2015
Customer: Standard type
Customers Part no.:
Page 1 of 2
Description

- Closed loop (compensation)
Current Sensor with magnetic field probe
- Printed circuit board mounting
- Casing and materials UL-listed

Characteristics

- Excellent accuracy
- Very low offset current
- Very low temperature dependency and offset current drift
- Very low hysteresis of offset current
- short response time
- Wide frequency bandwidth
- Compact design
- Reduced offset ripple

Applications

Mainly used for stationary operation in industrial applications:

- AC variable speed drives and servo motor drives
- Static converters for DC motor drives
- Battery supplied applications
- Switched Mode Power Supplies (SMPS)
- Power Supplies for welding applications
- Uninterruptible Power Supplies (UPS)

Electrical data – Ratings

		min.	typ.	max.	Einheit
I_{PN}	Primary nominal r.m.s. current			100	A
V_{out}	Output voltage @ I_P			$V_{Ref} \pm (0.625 \cdot I_P / I_{PN})$	V
\bar{V}_{out}	Output voltage @ $I_P=0, T_A=25^\circ C$			$V_{Ref} \pm 0.0025$	V
V_{Ref}	Reference voltage external	0		4	V
\bar{V}_{Ref}	Reference voltage internal			2.5 ± 0.005	V
K_N	Turns ratio			1 : 1000	

Accuracy – Dynamic performance data

		min.	typ.	max.	Unit
$I_{P,max}$	Max. measuring range	± 230			
X	Accuracy @ $I_{PN}, T_A=25^\circ C$			1	%
ϵ_L	Linearity			0.1	%
$V_{out} -2,5V$	Offset voltage @ $I_P=0, T_A=25^\circ C$			± 2.5	mV
$\Delta V_{out} / 2,5V / \Delta T$	Temperature drift of V_{out} @ $I_P=0, T_A=-40...85^\circ C$		3	10	ppm/K
t_r	Response time @ 80% von I_{PN}		1		μs
$\Delta t (I_{P,max})$	Delay time at $di/dt = 100 A/\mu s$		1		μs
f	Frequency bandwidth	DC...100			kHz

General data

		min.	typ.	max.	Unit
T_A	Ambient operating temperature	-40		+85	$^\circ C$
T_S	Ambient storage temperature	-40		+85	$^\circ C$
m	Mass		18		g
V_C	Supply voltage	4.75	5	5.25	V
I_{C0}	Current consumption		16		mA
S_{clear}	Clearance (component without solder pad)	12			mm
S_{creep}	Creepage (component without solder pad)	12			mm
V_{sys}	System voltage overvoltage category III			600	V_{RMS}
V_{work}	Working voltage (table 3 acc. to IEC 61800-5-1:2007) overvoltage category 2			1000	V_{RMS}
U_{PD}	Rated discharge voltage			1414	V_{peak}
	Max. potential difference acc to UL 508			600	V_{RMS}

Constructed and manufactured and tested in accordance with IEC 61800-5-1:2007 (Primary to Secondary)
 Reinforced insulation, Insulation material group 1, Pollution degree 2, Overvoltage category III

Date	Name	Issue	Amendment
07.04.15	DJ	81	Sensor changed back to issue "81". Data sheet changed. CN-15-276
11.11.14	DJ	82	Sensor optimised Marking changed from 4646X160 → 4646-X160. CN-14-123

Hrsg.: KB-E editor	Bearb: DJ designer		KB-PM: KRe. check		freig.: Berton released
-----------------------	-----------------------	--	----------------------	--	----------------------------

K-No.: 24959

100 A Current Sensor Module for 5V-Sply Voltage

For electronic current measurement:
DC, AC, pulsed, mixed ...,
with a galvanic isolation between
primary circuit (high power) and
secondary circuit (electronic circuit)

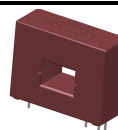

Date: 07.04.2015

Customer: Standard type

Customers Part no.:

Page 2 of 2

Mechanical outline (mm):

General tolerances DIN ISO 2768-c

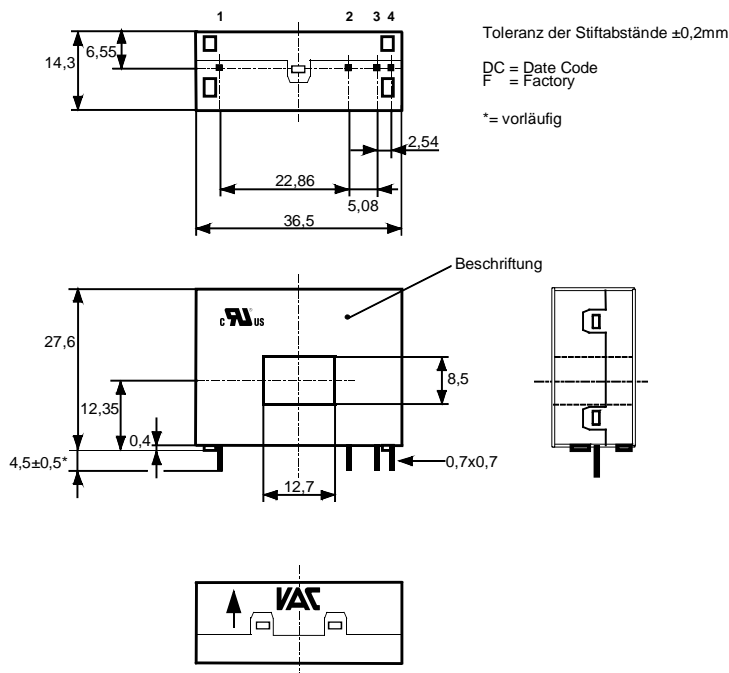

Connections:

1..4 = 0.7 x 0.7mm

Marking:

UL-sign
 4646-X160
 F DC

Schematic diagram

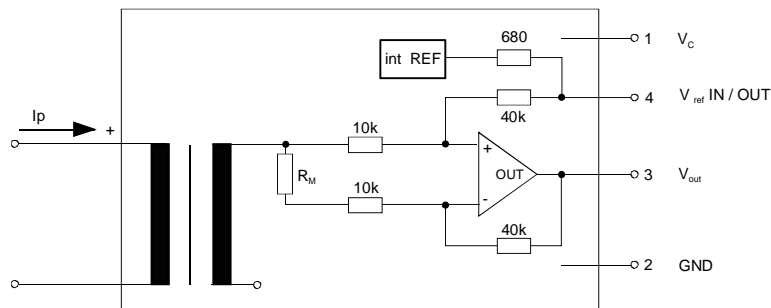

Additional information is obtainable on request.
Temperature of the primary conductor should not exceed 110°C.

Hrsg.: KB-E
editor

Bearb.: DJ
designer

KB-PM: KRe.
check

freig.: Berton
released

K-No.: 24959

100 A Current Sensor Module for 5V-Supply Voltage

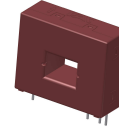
 For the electronic measurement of currents:
 DC, AC, pulsed, mixed ...,
 with a galvanic isolation between
 the primary circuit (high power)
 and the secondary circuit (electronic circuit)

Date: 07.04.2015

Customer:
Customers Part No.:

Page 1 of 2

Electrical Data

		min.	typ.	max.	Unit
V_{Ctot}	Maximum supply voltage (without function)			6	V
I_C	Supply Current with primary current		$16mA + I_p \cdot K_N + V_{out}/R_L$		mA
$I_{out,SC}$	Short circuit output current		± 20		mA
R_S	Secondary coil resistance @ $T_A=85^\circ C$			14	Ω
$R_{i,Ref}$	Internal resistance of Reference input		670		Ω
$R_{i,(V_{out})}$	Output resistance of V_{out}			1	Ω
R_L	External recommended resistance of V_{out}	1			k Ω
C_L	External recommended capacitance of V_{out}			500	pF
$\Delta X_T/\Delta T$	Temperature drift of X @ $T_A = -40 \dots +85^\circ C$			40	ppm/K
$\Delta V_0 = \Delta(V_{out} - V_{Ref})$	Sum of any offset drift including:		2	6	mV
V_{0t}	Long term drift of V_0		1		mV
V_{0T}	Temperature drift von V_0 @ $T_A = -40 \dots +85^\circ C$		1		mV
V_{0H}	Hystereses of V_{out} @ $I_p=0$ (after an overload of $10 \times I_{PN}$)			0.7	mV
$\Delta V_0/\Delta V_C$	Supply voltage rejection ratio			1	mV/V
V_{oss}	Offsetripple (with 1 MHz- filter first order)			20	mV
V_{oss}	Offsetripple (with 100 kHz- filter first order)		2.5	6	mV
V_{oss}	Offsetripple (with 20 kHz- filter first order)		0.7	1.5	mV
C_k	Maximum possible coupling capacity (primary – secondary) Mechanical stress according to M3209/3 Settings: 10 Hz, 1 min/Oktave, 2 hours		6		pF

Inspection (Measurement after temperature balance of the samples at room temperature, SC = significant characteristic)

$V_{out}(SC)$	(V)	M3011/6:	Output voltage vs. internal reference ($I_p=100A$, 40-80Hz)	$625 \pm 0.7\%$	mV
$V_{out} - V_{Ref}$	(V)	M3226:	Offset voltage	± 0.0025	V
V_d	(V)	M3014:	Test voltage, RMS, 1 s pin 1-4 to inner hole	1.8	kV
V_e	(AQL 1/S4):		Partial discharge voltage acc.M3024 with V_{vor}	1500 1875	V_{RMS} V_{RMS}

Type Testing (Pin 1-4 to inner hole)

V_W			HV transient test according to M3064 (1,2 μs / 50 μs -wave form)	8	kV
V_d			Testing voltage to M3024	(5 s)	3.6 kV
V_e			Partial discharge voltage acc.M3024 with V_{vor}	1500 1875	V_{RMS} V_{RMS}

Applicable documents

 Current direction: A positive output current appears at point I_s , by primary current in direction of the arrow.
 Enclosures according to IEC529: IP50.

Further standards UL 508, file E317483, category NMTR2 / NMTR8

Date	Name	Issue	Amendment
07.04.15	DJ	81	Sensor changed back to issue "81". data sheet changed. CN-15-276
11.11.14	DJ	82	Sensor optimised. CN-14-123

Hrsg.: KB-E editor	Bearb.: DJ designer		KB-PM: KRe. check		freig.: Berton released
-----------------------	------------------------	--	----------------------	--	----------------------------

K-No.: 24959

100 A Current Sensor Module for 5V-Supply Voltage

For the electronic measurement of currents:
 DC, AC, pulsed, mixed ...,
 with a galvanic isolation between
 the primary circuit (high power)
 and the secondary circuit (electronic circuit)

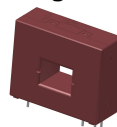
Date: 07.04.2015

Customer:
Customers Part No.:
Page 2 **of** 2

Explanation of several of the terms used in the tablets (in alphabetical order)

t_r: Response time (describe the dynamic performance for the specified measurement range), measured as delay time at $I_P = 0.8 \cdot I_{PN}$ between a rectangular current and the output voltage $V_{out}(I_P)$

$\Delta t(I_{Pmax})$: Delay time (describe the dynamic performance for the rapid current pulse rate e.g short circuit current) measured between I_{Pmax} and the output voltage $V_{out}(I_{Pmax})$ with a primary current rise of $di_P/dt \geq 100 A/\mu s$.

U_{PD} Rated discharge voltage (recurring peak voltage separated by the insulation) proved with a sinusoidal voltage V_{work}
 $U_{PD} = \sqrt{2} \cdot V_{work}$

V_{vor} Defined voltage is the RMS value of a sinusoidal voltage with peak value of $1.875 \cdot U_{PD}$ required for partial discharge test in IEC 61800-5-1:2007
 $V_{vor} = 1.875 \cdot U_{PD} / \sqrt{2}$

V_{sys} System voltage value of rated voltage according to IEC 61800-5-1:2007.

V_{work} Working voltage voltage according to IEC 61800-5-1:2007 which occurs by design in a circuit or across insulation.

V₀: Offset voltage between V_{out} and the rated reference voltage of $V_{ref} = 2.5V$.
 $V_0 = V_{out}(0) - 2.5V$

V_{0H}: Zero variation of V_0 after overloading with a DC of tenfold the rated value

V_{0t}: Long term drift of V_0 after 100 temperature cycles in the range -40 bis 85 °C.

X: Permissible measurement error in the final inspection at RT, defined by

$$X = 100 \cdot \left| \frac{V_{out}(I_{PN}) - V_{out}(0)}{0,625V} - 1 \right| \%$$

X_{ges}(I_{PN}): Permissible measurement error including any drifts over the temperature range by the current measurement I_{PN}

$$X_{ges} = 100 \cdot \left| \frac{V_{out}(I_{PN}) - 2,5V}{0,625V} - 1 \right| \% \quad \text{or} \quad X_{ges} = 100 \cdot \left| \frac{V_{out}(I_{PN}) - V_{ref}}{0,625V} - 1 \right| \%$$

ϵ_L : Linearity fault defined by $\epsilon_L = 100 \cdot \left| \frac{I_P}{I_{PN}} - \frac{V_{out}(I_P) - V_{out}(0)}{V_{out}(I_{PN}) - V_{out}(0)} \right| \%$

Hrsg.: KB-E
 editor

Bearb.: DJ
 designer

KB-PM: KRe.
 check

freig.: Berton
 released

Компания «Life Electronics» занимается поставками электронных компонентов импортного и отечественного производства от производителей и со складов крупных дистрибьюторов Европы, Америки и Азии.

С конца 2013 года компания активно расширяет линейку поставок компонентов по направлению коаксиальный кабель, кварцевые генераторы и конденсаторы (керамические, пленочные, электролитические), за счёт заключения дистрибьюторских договоров

Мы предлагаем:

- Конкурентоспособные цены и скидки постоянным клиентам.
- Специальные условия для постоянных клиентов.
- Подбор аналогов.
- Поставку компонентов в любых объемах, удовлетворяющих вашим потребностям.
- Приемлемые сроки поставки, возможна ускоренная поставка.
- Доставку товара в любую точку России и стран СНГ.
- Комплексную поставку.
- Работу по проектам и поставку образцов.
- Формирование склада под заказчика.
- Сертификаты соответствия на поставляемую продукцию (по желанию клиента).
- Тестирование поставляемой продукции.
- Поставку компонентов, требующих военную и космическую приемку.
- Входной контроль качества.
- Наличие сертификата ISO.

В составе нашей компании организован Конструкторский отдел, призванный помогать разработчикам, и инженерам.

Конструкторский отдел помогает осуществить:

- Регистрацию проекта у производителя компонентов.
- Техническую поддержку проекта.
- Защиту от снятия компонента с производства.
- Оценку стоимости проекта по компонентам.
- Изготовление тестовой платы монтаж и пусконаладочные работы.



Тел: +7 (812) 336 43 04 (многоканальный)

Email: org@lifeelectronics.ru