

FUJITSU Component Thermal Printer FTP-66E Series (6-inch thermal printer)

Fujitsu 12/24V, 6" high speed, easy loading thermal printer

Overview

The easy loading FTP-66E MCL Series is ultra compact high speed, 12/24V driven thermal printer, printing on 6-inch wide paper (156mm) where platens are removable. Our original platen removal mechanism improved paper loading and maintenance.

The FTP-66E MCL series can be used for a variety of applications, such as measurement and medical equipment, banking, and banking terminals.

RoHS compliant

Features

- **Compact 6-inch mechanism**
Small size, 6-inch wide paper (max. paper width 156mm)
- **Platen open structure**
Easy paper set or jam release / easy maintenance
- **High speed printing**
It can print at 100mm/s at 24V driving
- **Label paper available**
Straight paper pass
- **UL File No. E171434**



FTP-66EMCL101

Item	Part Number
Printer mechanism	FTP-66EMCL101
LSI for driving	TBD
Interface board	FTP-62EDSL011#01
Head extension cable	FTP-62EY001
USB cable	FTP-629Y301#01
Power cable	FTP-629Y601

Item	Specifications		
Part number	FTP-66EMCL101		
Printing method	Thermal-line dot method		
Dot structure	1152 dots/lines		
Dot pitch (horizontal)	0.125mm (dot density: 8 dots/mm)		
Dot pitch (vertical)	0.125mm (dot density: 8 dots/mm)		
Effective printing area	144mm		
Paper	Width	156mm	
	Thickness	60µm to 100µm	
Operating voltage	Head	For print	At 12V driving: 12VDC ±10%, approx. 8.0A (applied dot number 583 dots) At 24V driving: 24VDC ±10%, approx. 8.0A (applied dot number 256 dots)
		For logic	3.0VDC to 3.6VDC or 4.75VDC to 5.25VDC, 0.2A maximum
	Motor	For print	12V driving: 12VDC ±10%, 0.6A at single-phase excitation, 0.8A at double-phase excitation 24V driving: 24VDC ±10%, 0.6A at single-phase excitation, 0.8A at double-phase excitation
Printing speed	At 12V driving: max. 50mm/sec. (400 dotlines/sec.)* At 24V driving: max. 100mm/sec. (800 dotlines/sec.)*		
Dimensions	Printer mechanism	194.6 x 55.2 x 26.0mm (WxDxH, except flexible printed board and projection portion)	
Weight	Printer mechanism	Approximately 430g	
Head life	Pulse resistance	100 million pulse/dot (under FCL standard conditions)	
	Wear resistance	Paper traveling distance 50km (print ratio: 12.5%, using specified thermal paper)	
Operating environment	Operating temperature**	0°C to 50°C	
	Operating humidity	12 to 85% RH (no frost)	
	Storage temperature	-10°C to +60°C	
	Storage humidity	5 to 90% RH (excluding paper, no frost)	
Detection function	Head temperature detection	Thermistor	
	Paper out / mark detection	Photo sensor	
Recommended thermal sensitive paper	High sensitive paper	TF50KS-E	
	Standard paper	PD150R, TF60KS-E	
	Medium life storage paper	PD170R, TP60KS-F1, P220VBB-1	
	Long life storage paper	PD160R	

*: at 25°C, high speed printing mode, using specified thermal paper)

***: +5° to +40°C printing density assurance range (with Oji paper PD150R)

■ Dimension

- Printer mechanism: 6-inch

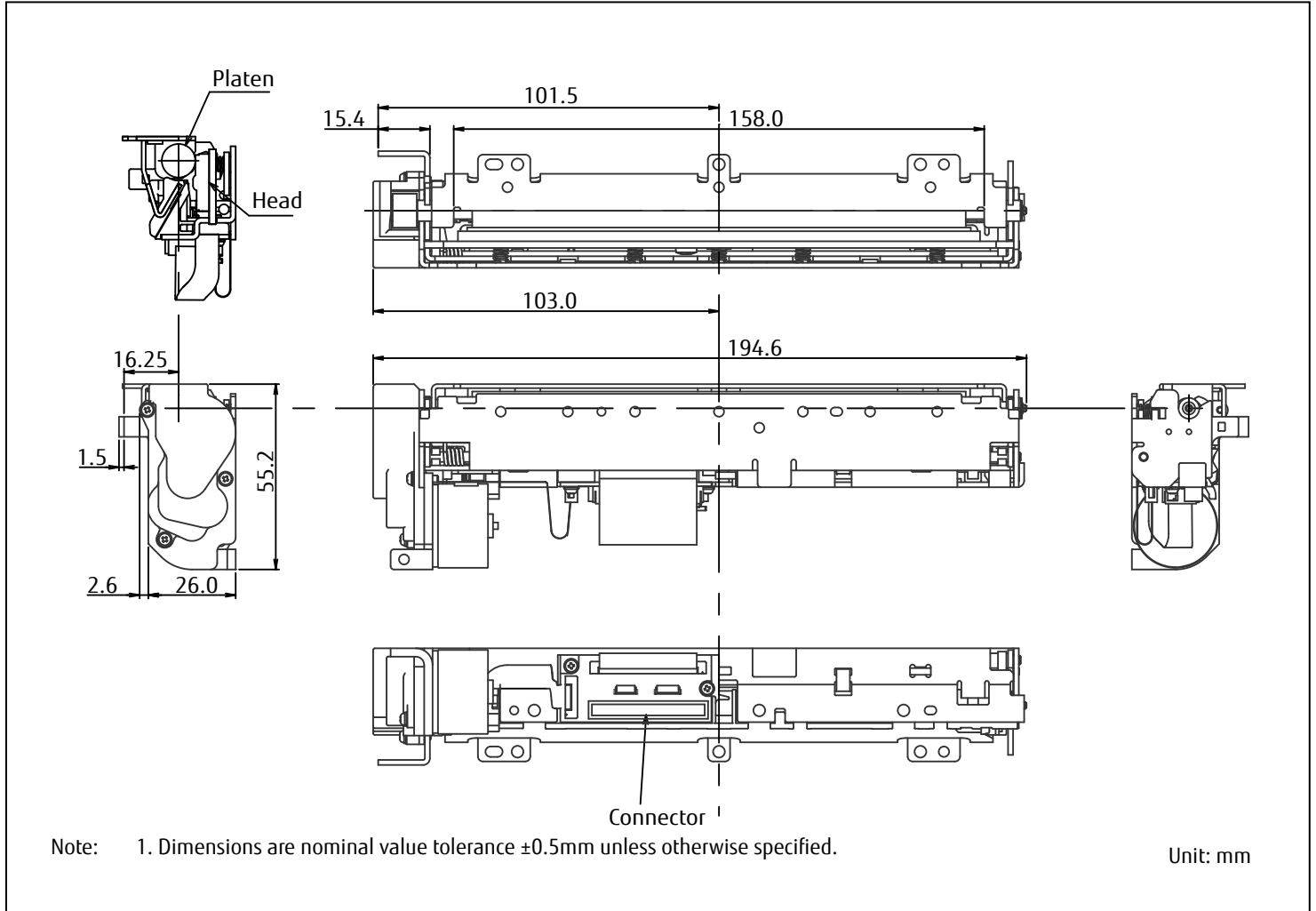

■ Option

Item	Part Number	MOQ
Lever cap	FTP-68EMP0495	20 pieces

■ Interface board

Standard interface board is not available. We only offer an evaluation board. Please contact our sales office for details.

Contact

Japan

FUJITSU COMPONENT LIMITED
Shinagawa Seaside Park Tower
12-4, Higashi-shinagawa 4-chome,
Tokyo 140 0002, Japan
Tel: (81-3) 3450-1682
Fax: (81-3) 3474-2385
Email: fcl-contact@cs.jp.fujitsu.com
Web: www.fujitsu.com/jp/fcl/

North and South America

FUJITSU COMPONENTS AMERICA, INC.
2290 North First Street, Suite 212
San Jose, CA 95131 U.S.A.
Tel: (1-408) 745-4900
Fax: (1-408) 745-4970
Email: components@us.fujitsu.com
Web: http://us.fujitsu.com/components/

Europe

FUJITSU COMPONENTS EUROPE B.V.
Diamantlaan 25
2132 WV Hoofddorp
Netherlands
Tel: (31-23) 5560910
Fax: (31-23) 5560950
Email: info@fceu.fujitsu.com
Web: www.fujitsu.com/uk/components/

Asia Pacific

FUJITSU COMPONENTS ASIA, Ltd.
102E Pasir Panjang Road
#01-01 Citilink Warehouse Complex,
Singapore 118529
Tel: (65) 6375-8560 / Fax: (65) 6273-3021
Email: fcal@sg.fujitsu.com
www.fujitsu.com/sg/products/devices/components/

China

FUJITSU ELECTRONIC COMPONENTS
(SHANGHAI) CO., LTD.
Unit 4306, InterContinental Center
100 Yu Tong Road, Shanghai 200070, China
Tel: (86 21) 3253 0998
Fax: (86 21) 3253 0997
Email: fcal@sgfujitsu.com
www.fujitsu.com/sg/products/devices/components/

Hong Kong

FUJITSU COMPONENTS HONG KONG Co., Ltd.
Unit 503, Inter-Continental Plaza,
No.94 Granville Road,
Tsim Sha Tsui Kowloon, Hong Kong 118529
Tel: (852) 2881 8495 Fax: (852) 2894 9512
Email: fcal@sg.fujitsu.com
www.fujitsu.com/sg/products/devices/components/

Copyright

All trademarks or registered trademarks are the property of their respective owners.
Fujitsu Components America or its affiliates do not warrant that the content of datasheet is error free. In a continuing effort to improve our products Fujitsu Components America, Inc. or its affiliates reserve the right to change specifications/datasheets without prior notice. Copyright ©2016 Fujitsu Components America, Inc.
All rights reserved.
Revised May 10, 2016

Компания «Life Electronics» занимается поставками электронных компонентов импортного и отечественного производства от производителей и со складов крупных дистрибьюторов Европы, Америки и Азии.

С конца 2013 года компания активно расширяет линейку поставок компонентов по направлению коаксиальный кабель, кварцевые генераторы и конденсаторы (керамические, пленочные, электролитические), за счёт заключения дистрибьюторских договоров

Мы предлагаем:

- Конкурентоспособные цены и скидки постоянным клиентам.
- Специальные условия для постоянных клиентов.
- Подбор аналогов.
- Поставку компонентов в любых объемах, удовлетворяющих вашим потребностям.
- Приемлемые сроки поставки, возможна ускоренная поставка.
- Доставку товара в любую точку России и стран СНГ.
- Комплексную поставку.
- Работу по проектам и поставку образцов.
- Формирование склада под заказчика.
- Сертификаты соответствия на поставляемую продукцию (по желанию клиента).
- Тестирование поставляемой продукции.
- Поставку компонентов, требующих военную и космическую приемку.
- Входной контроль качества.
- Наличие сертификата ISO.

В составе нашей компании организован Конструкторский отдел, призванный помогать разработчикам, и инженерам.

Конструкторский отдел помогает осуществить:

- Регистрацию проекта у производителя компонентов.
- Техническую поддержку проекта.
- Защиту от снятия компонента с производства.
- Оценку стоимости проекта по компонентам.
- Изготовление тестовой платы монтаж и пусконаладочные работы.



Тел: +7 (812) 336 43 04 (многоканальный)

Email: org@lifeelectronics.ru