

Customer Information Sheet

DRAWING No.: G125-FCXXX05FI-XXXXL

IF IN DOUBT - ASK

©

NOT TO SCALE

THIRD ANGLE PROJECTION

ALL DIMENSIONS IN mm

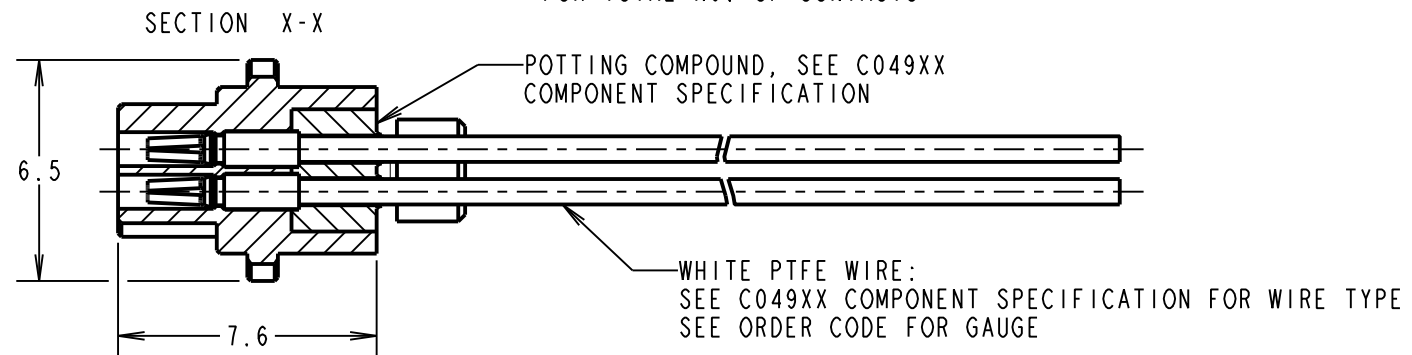
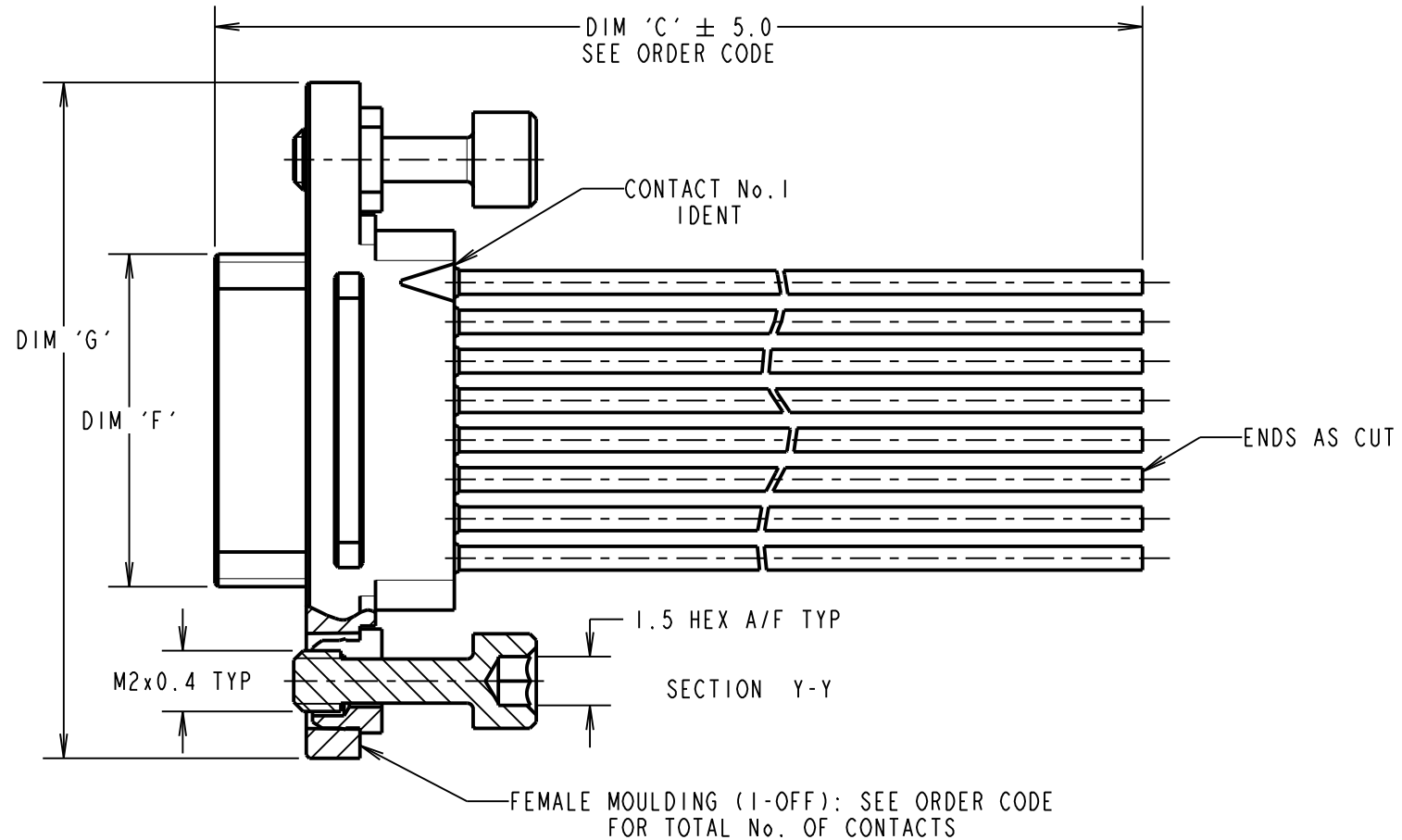
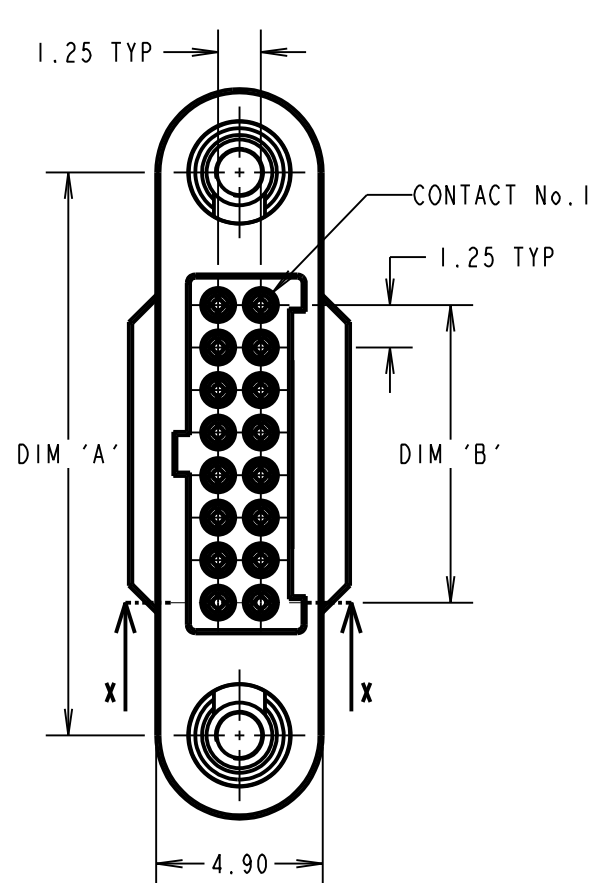

DIMENSION	MEASUREMENT
DIM 'A'	(TOTAL No. OF CONTACTS - 2) x 0.625 + 7.80
DIM 'B'	(TOTAL No. OF CONTACTS - 2) x 0.625 ± 0.20
DIM 'F'	(TOTAL No. OF CONTACTS - 2) x 0.625 + 1.80
DIM 'G'	(TOTAL No. OF CONTACTS - 2) x 0.625 + 12.7

EXAMPLE PART No.
 12 CONTACT CONNECTOR WITH 150mm OF 26AWG WIRE = G125-FC11205F2-0150L
 50 CONTACT CONNECTOR WITH 450mm OF 28AWG WIRE = G125-FC25005F2-0450L

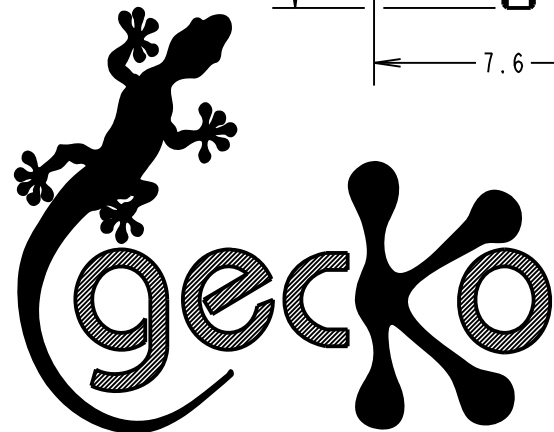

PATENTED TECHNOLOGY

ORDER CODE:

G125-FCXXX05FI-XXXXL

26 AWG = 1
 28 AWG = 2

TOTAL No. OF CONTACTS:
 06, 10, 12, 16,
 20, 26, 34, 50

DIM 'C' LENGTH:
 0060 = 60mm MIN
 9999 = 9999mm MAX

STOCKED LENGTHS:
 0150 = 150mm
 0300 = 300mm
 0450 = 450mm

RTP	3	09.04.19	21781
NAME	ISS.	DATE	C/NOTE
APPROVED: R.PORTLOCK			
CHECKED: S.BENNETT			
DRAWN: M.PERREN			
CUSTOMER REF.:			
ASSEMBLY DRG:			

NOTES:

- CABLE ASSEMBLIES WILL BE PACKED IN BAGS OF 10.
- CUSTOM LENGTH CABLE ASSEMBLIES CAN BE PRODUCED FROM 60mm TO 9999mm. CONTACT OUR CABLE TEAM ON CABLES@HARWIN.COM.
- FOR COMPLETE SPECIFICATION, SEE COMPONENT SPECIFICATIONS C049XX AND C125XX (LATEST ISSUES).

HARWIN

www.harwin.com
 technical@harwin.com

THIS DRAWING AND ANY INFORMATION OR DESCRIPTIVE MATTER SET OUT HEREON ARE CONFIDENTIAL AND COPYRIGHT PROPERTY OF THE HARWIN GROUP AND MUST NOT BE DISCLOSED, LOANED, COPIED OR USED FOR MANUFACTURING, TENDERING OR FOR ANY OTHER PURPOSE WITHOUT THEIR WRITTEN PERMISSION.

TOLERANCES

X. = ±1mm
 X.X = ±0.50mm
 X.XX = ±0.20mm
 X.XXX = ±0.01mm
 ANGLES = ±5°
 UNLESS STATED

MATERIAL:

SEE ABOVE

FINISH:

SEE ABOVE

S/AREA:

mm²

TITLE:

GECKO SL FEMALE CRIMP CONNECTOR WITH PIGTAIL

DRAWING NUMBER:

G125-FCXXX05FI-XXXXL

SHT
 3
 OF
 3

Customer Information Sheet

DRAWING No.: G125-SERIES COMPONENT SPECIFICATION

IF IN DOUBT - ASK

©

NOT TO SCALE

THIRD ANGLE PROJECTION

ALL DIMENSIONS IN mm

SPECIFICATIONS:

MATERIALS:

MOULDING, PICK & PLACE CAP:
POLYAMIDE, PA4T-GF30 FR(40) UL94V-0,
HALOGEN FREE, FREE OF RED PHOSPHORUS

CONTACTS:

SIGNAL CONTACTS:
MALE PC-TAIL/SMT = PHOSPHOR BRONZE
MALE CRIMP = BRASS
ALL FEMALE CONTACTS = BERYLLIUM COPPER
POWER CONTACTS:
ALL CONTACTS = BERYLLIUM COPPER

LOCKING HARDWARE:

LATCHES: COPPER NICKEL TIN ALLOY
SCREW LOCK: STAINLESS STEEL

BACK POTTING COMPOUND (CABLE ASSEMBLIES ONLY):
STYCAST 2651 MM BACK POTTING WITH CATALYST 9

FINISH:

ALL SIGNAL CONTACTS:
0.2-0.3µm GOLD OVER NICKEL
ALL POWER CONTACTS:
0.76-1.00µm GOLD OVER 1.50-2.50µm NICKEL
AND COPPER FLASH
LATCHES:
3.0µm 100% TIN OVER NICKEL

MECHANICAL:

DURABILITY = 1000 OPERATIONS
RETENTION IN HOUSING (ALL CONTACTS) = 6.0N MIN
SIGNAL CONTACTS:
INSERTION FORCE = 2.8N MAX
WITHDRAWAL FORCE = 0.2N MIN
POWER CONTACTS:
INSERTION FORCE = 7.0N MAX
WITHDRAWAL FORCE = 0.2N MIN
SCREW-LOK:
RETENTION IN HOUSING = 20.0N MIN
LATCHES:
RETENTION IN HOUSING = 4.0N MIN

ENVIRONMENTAL:

CLASSIFICATION: 65/150/56 DAYS AT 93% RH

TEMPERATURE RANGE:

* EIA-364-32 : 2000 TEST CONDITION IV, DWELL
30mins, 5 CYCLES -65°C TO +150°C

MECHANICAL:

VIBRATION AND SHOCK:

* EIA-364-28D : 1999: TEST CONDITION IV: VIBRATION SEVERITY:
10Hz TO 2000Hz, 1.5mm, 198mm/s² (20G). DURATION 2Hr
* EIA-364-28D : 1999: TEST CONDITION IV: VIBRATION SEVERITY:
10Hz TO 2000Hz, 1.5mm, 198mm/s² (20G). DURATION 2Hr
* EIA-364-27B : 1996: TEST CONDITION E SHOCK SEVERITY: 981mm/s²
(100G) FOR 6ms IN Z AXIS, 490mm/s² (50G) FOR 11m/s IN X & Y AXIS.
* EIA-364-01A : 2000: ACCELERATION: 490mm/s² (50G)
* BUMP SEVERITY: 390mm/s² (40G), 4000±10 BUMPS
* TESTED WITH LATCHED CONNECTORS

ELECTRICAL:

CURRENT RATING:

SIGNAL CONTACTS:

EIA-364-70A : 1998: INDIVIDUAL CONTACT IN ISOLATION AT 25°C = 2.8A MAX
EIA-364-70A : 1998: ALL CONTACTS SIMULTANEOUSLY AT 25°C = 2.0A MAX

POWER CONTACTS:

EIA-364-70A : 1998: PER CONTACT, THROUGH ALL CONTACTS = 10A MAX

CONTACT RESISTANCE:

EIA-364-06C : 2006: INITIAL CONTACT RESISTANCE = 20mΩ MAX
EIA-364-06C : 2006: CONTACT RESISTANCE AFTER CONDITIONING = 25mΩ MAX

VOLTAGE PROOF:

EIA-364-20C : 2004: SEA LEVEL (1013mbar) = 600V DC/AC PEAK
EIA-364-20C : 2004: ALTITUDE LEVEL (44mbar, 21,336m/70,000ft) = 350V DC/AC PEAK

WORKING VOLTAGE:

AT SEA LEVEL (1006mbar) = 450V DC/AC PEAK
AT ALTITUDE (44mbar, 21,336m/70,000ft) = 250V DC/AC PEAK

INSULATION RESISTANCE:

EIA-364-21C : 2000: INSULATION RESISTANCE (INITIAL)
= 10GΩ MIN AT 500V DC
EIA-364-21C : 2000: INSULATION RESISTANCE (AFTER CONDITIONING)
= >1GΩ MIN AT 500V DC

FOR FULL COMPONENT SPECIFICATION SEE C125XX (LATEST ISSUE).

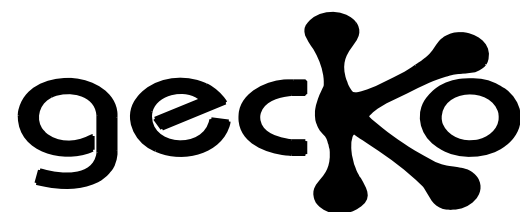

PATENTED TECHNOLOGY

HARWIN

www.harwin.com
technical@harwin.com

THIS DRAWING AND ANY INFORMATION OR DESCRIPTIVE MATTER SET OUT HEREON ARE CONFIDENTIAL AND COPYRIGHT PROPERTY OF THE HARWIN GROUP AND MUST NOT BE DISCLOSED, LOANED, COPIED OR USED FOR MANUFACTURING, TENDERING OR FOR ANY OTHER PURPOSE WITHOUT THEIR WRITTEN PERMISSION.

TOLERANCES

X. = ±1mm
X.X = ±0.50mm
X.XX = ±0.20mm
X.XXX = ±0.01mm
ANGLES = ±5°
UNLESS STATED

MATERIAL:

SEE ABOVE

FINISH:

SEE ABOVE

S/AREA:

mm²

TITLE:

G125 SERIES COMPONENT SPECIFICATION

DRAWING NUMBER:

G125-SERIES CONNECTORS

SHT
1
OF
1

RTP	5	04.10.19	22083
NAME	ISS.	DATE	C/NOTE
APPROVED:		R.PORTLOCK	
CHECKED:		S.BENNETT	
DRAWN:		S.FLOWER	
CUSTOMER REF.:			
ASSEMBLY DRG:			

Компания «Life Electronics» занимается поставками электронных компонентов импортного и отечественного производства от производителей и со складов крупных дистрибьюторов Европы, Америки и Азии.

С конца 2013 года компания активно расширяет линейку поставок компонентов по направлению коаксиальный кабель, кварцевые генераторы и конденсаторы (керамические, пленочные, электролитические), за счёт заключения дистрибьюторских договоров

Мы предлагаем:

- Конкурентоспособные цены и скидки постоянным клиентам.
- Специальные условия для постоянных клиентов.
- Подбор аналогов.
- Поставку компонентов в любых объемах, удовлетворяющих вашим потребностям.
- Приемлемые сроки поставки, возможна ускоренная поставка.
- Доставку товара в любую точку России и стран СНГ.
- Комплексную поставку.
- Работу по проектам и поставку образцов.
- Формирование склада под заказчика.
- Сертификаты соответствия на поставляемую продукцию (по желанию клиента).
- Тестирование поставляемой продукции.
- Поставку компонентов, требующих военную и космическую приемку.
- Входной контроль качества.
- Наличие сертификата ISO.

В составе нашей компании организован Конструкторский отдел, призванный помогать разработчикам, и инженерам.

Конструкторский отдел помогает осуществить:

- Регистрацию проекта у производителя компонентов.
- Техническую поддержку проекта.
- Защиту от снятия компонента с производства.
- Оценку стоимости проекта по компонентам.
- Изготовление тестовой платы монтаж и пусконаладочные работы.



Тел: +7 (812) 336 43 04 (многоканальный)

Email: org@lifeelectronics.ru