

2-Port USB 2.0 Hi-Speed Hub Controller

PRODUCT FEATURES

Datasheet

General Description

The SMSC USB2412 hub is a low-power, single transaction translator (STT) hub controller IC with two downstream ports for embedded USB applications. The SMSC hub controller supports low-speed, full-speed, and hi-speed (if operating as a hi-speed hub) downstream devices on all of the enabled downstream ports.

Features

- Fully integrated USB termination and pull-up/pull-down resistors
- Supports a single external 3.3 V supply source; internal regulators provide 1.2 V internal core voltage
- On-chip 24 MHz crystal driver or external 24 MHz clock input
- ESD protection up to 4 kilovolts on all USB pins
- Supports self-powered operation
- Contains a built-in default configuration; no external configuration options or components are required
- Downstream ports as optional non-removable ports
- Supports compound devices on a port-by-port basis
- 28-pin QFN (5 x 5 mm) lead-free RoHS compliant package
- Supports the commercial temperature range: 0°C to +70°C

Highlights

- High performance, low-power, small footprint hub controller IC with two downstream ports
- Fully compliant with the *USB 2.0 Specification 1*.
- 28QFN low pin count package
- Optimized for minimal bill-of-materials and low cost designs

Applications

- Automobile/home audio systems
- Cable/DSL modems
- Embedded systems
- Gaming consoles
- HDD enclosures
- IP telephony
- KVM switches
- LCD monitors and TVs
- Multi-function USB peripherals
- Mobile PC docking
- PC motherboards
- PC media drive bay
- Portable hub boxes
- Point-of-Sale (POS) systems
- Printers and scanners
- Server front panels
- Set-top boxes, DVD players, DVR/PVR
- Thin client terminals

Order Numbers:

ORDER NUMBERS*	LEAD-FREE ROHS COMPLIANT PACKAGE	PACKAGE SIZE	REEL SIZE
USB2412-DZK	28-Pin QFN Lead-Free, RoHS Compliant Package (includes tape and reel option)	5 x 5 x 0.5 mm	-
USB2412-DZK-TR			

This product meets the halogen maximum concentration values per IEC61249-2-21
 For RoHS compliance and environmental information, please visit www.smsc.com/rohs



80 ARKAY DRIVE, HAUPPAUGE, NY 11788 (631) 435-6000 or 1 (800) 443-SEMI

Copyright © 2011 SMSC or its subsidiaries. All rights reserved.

Circuit diagrams and other information relating to SMSC products are included as a means of illustrating typical applications. Consequently, complete information sufficient for construction purposes is not necessarily given. Although the information has been checked and is believed to be accurate, no responsibility is assumed for inaccuracies. SMSC reserves the right to make changes to specifications and product descriptions at any time without notice. Contact your local SMSC sales office to obtain the latest specifications before placing your product order. The provision of this information does not convey to the purchaser of the described semiconductor devices any licenses under any patent rights or other intellectual property rights of SMSC or others. All sales are expressly conditional on your agreement to the terms and conditions of the most recently dated version of SMSC's standard Terms of Sale Agreement dated before the date of your order (the "Terms of Sale Agreement"). The product may contain design defects or errors known as anomalies which may cause the product's functions to deviate from published specifications. Anomaly sheets are available upon request. SMSC products are not designed, intended, authorized or warranted for use in any life support or other application where product failure could cause or contribute to personal injury or severe property damage. Any and all such uses without prior written approval of an Officer of SMSC and further testing and/or modification will be fully at the risk of the customer. Copies of this document or other SMSC literature, as well as the Terms of Sale Agreement, may be obtained by visiting SMSC's website at <http://www.smsc.com>. SMSC is a registered trademark of Standard Microsystems Corporation ("SMSC"). Product names and company names are the trademarks of their respective holders.

SMSC DISCLAIMS AND EXCLUDES ANY AND ALL WARRANTIES, INCLUDING WITHOUT LIMITATION ANY AND ALL IMPLIED WARRANTIES OF MERCHANTABILITY, FITNESS FOR A PARTICULAR PURPOSE, TITLE, AND AGAINST INFRINGEMENT AND THE LIKE, AND ANY AND ALL WARRANTIES ARISING FROM ANY COURSE OF DEALING OR USAGE OF TRADE. IN NO EVENT SHALL SMSC BE LIABLE FOR ANY DIRECT, INCIDENTAL, INDIRECT, SPECIAL, PUNITIVE, OR CONSEQUENTIAL DAMAGES; OR FOR LOST DATA, PROFITS, SAVINGS OR REVENUES OF ANY KIND; REGARDLESS OF THE FORM OF ACTION, WHETHER BASED ON CONTRACT; TORT; NEGLIGENCE OF SMSC OR OTHERS; STRICT LIABILITY; BREACH OF WARRANTY; OR OTHERWISE; WHETHER OR NOT ANY REMEDY OF BUYER IS HELD TO HAVE FAILED OF ITS ESSENTIAL PURPOSE, AND WHETHER OR NOT SMSC HAS BEEN ADVISED OF THE POSSIBILITY OF SUCH DAMAGES.

Conventions

Within this manual, the following abbreviations and symbols are used to improve readability.

Example	Description
BIT	Name of a single bit within a field
FIELD.BIT	Name of a single bit (BIT) in FIELD
x...y	Range from x to y, inclusive
BITS[m:n]	Groups of bits from m to n, inclusive
PIN	Pin Name
zzzzb	Binary number (value zzzz)
0zzzz	Hexadecimal number (value zzz)
zzh	Hexadecimal number (value zz)
rsvd	Reserved memory location. Must write 0, read value indeterminate
code	Instruction code, or API function or parameter
<i>Section Name</i>	Section or Document name
x	Don't care
<Parameter>	<> indicate a Parameter is optional or is only used under some conditions
{,Parameter}	Braces indicate Parameter(s) that repeat one or more times
[Parameter]	Brackets indicate a nested Parameter. This Parameter is not real and actually decodes into one or more real parameters.

Table of Contents

Chapter 1	Block Diagram	7
<hr/>		
Chapter 2	Pin Descriptions	8
2.1	Pin Configuration	8
2.2	28-Pin Table	9
2.3	Pin Descriptions (Grouped by Function)	10
2.4	Buffer Type Descriptions	12
2.5	Strap Option Pins	12
<hr/>		
Chapter 3	Internal Default Configuration	14
3.1	Hub Configuration	14
3.2	Reset	14
3.2.1	External Hardware RESET_N	14
3.2.2	USB Bus Reset	15
<hr/>		
Chapter 4	DC Parameters	16
4.1	Maximum Guaranteed Ratings	16
4.2	Operating Conditions	16
4.2.1	Pin Capacitance	19
4.2.2	Package Thermal Specifications	19
<hr/>		
Chapter 5	AC Specifications	20
5.1	Oscillator/Crystal	20
5.2	External Clock	21
5.2.1	USB 2.0	21
<hr/>		
Chapter 6	Package Outline	22
6.1	Tape and Reel Specification	24

List of Figures

Figure 1.1	USB2412 Block Diagram	7
Figure 2.1	USB2412 28-Pin QFN	8
Figure 2.2	Non-Removable Pin Strap Example	12
Figure 2.3	LED Pin Strap Example	13
Figure 3.1	Reset_N Timing	15
Figure 4.1	Supply Rise Time Model	17
Figure 5.1	Typical Crystal Circuit	20
Figure 5.2	Formula to Find the Value of C1 and C2	20
Figure 6.1	USB2412 28-Pin QFN Package Outline (5x5 mm Body, 0.5 Pitch, 3.1 ePad)	22
Figure 6.2	Recommended Printed Circuit Board (PCB) Land Pattern	23
Figure 6.3	28-Pin Package Tape Dimensions and Part Orientation (mm)	24
Figure 6.4	28-Pin Package Tape Length and Part Quantity	24
Figure 6.5	Package Reel Specifications	25

List of Tables

Table 2.1	USB2412 28-Pin Table	9
Table 2.2	USB2412 Pin Descriptions	10
Table 2.3	Buffer Type Descriptions	12
Table 3.1	Reset_N Timing	15
Table 4.1	DC Electrical Characteristics	17
Table 4.2	Pin Capacitance	19
Table 4.3	28-Pin QFN Package Thermal Parameters	19
Table 5.1	Crystal Circuit Legend	20
Table 6.1	Package Parameters	22

Chapter 1 Block Diagram

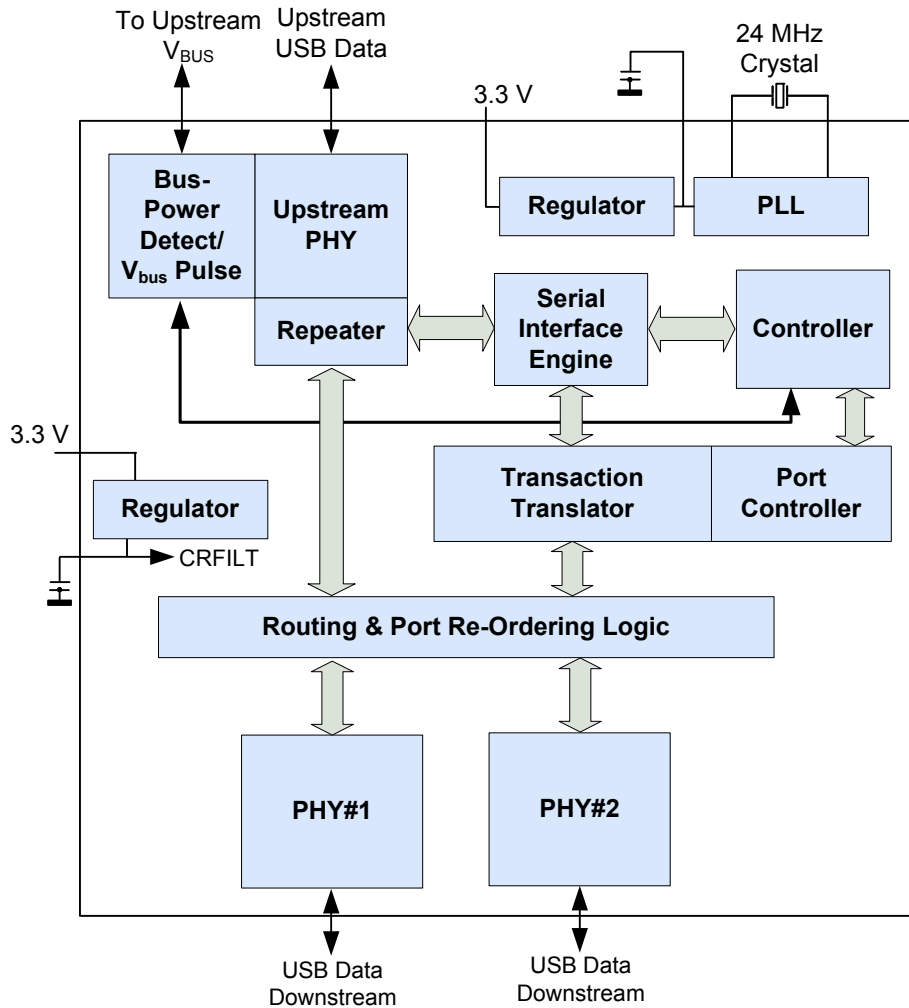

Figure 1.1 USB2412 Block Diagram

Chapter 2 Pin Descriptions

This chapter is organized by a set of pin configurations followed by a corresponding pin list organized by function according to their associated interface. A detailed description list of each signal (named in the pin list) is organized by function in [Table 2.2, “USB2412 Pin Descriptions,” on page 10](#). Refer to [Table 2.3, “Buffer Type Descriptions,” on page 12](#) for a list of buffer types.

The “N” symbol in the signal name indicates that the active, or asserted, state occurs when the signal is at a low voltage level. When “N” is not present after the signal name, the signal is asserted when it is at the high voltage level.

The terms assertion and negation are used exclusively. This is done to avoid confusion when working with a mixture of “active low” and “active high” signals. The term assert, or assertion, indicates that a signal is active, independent of whether that level is represented by a high or low voltage. The term negate, or negation, indicates that a signal is inactive.

2.1 Pin Configuration

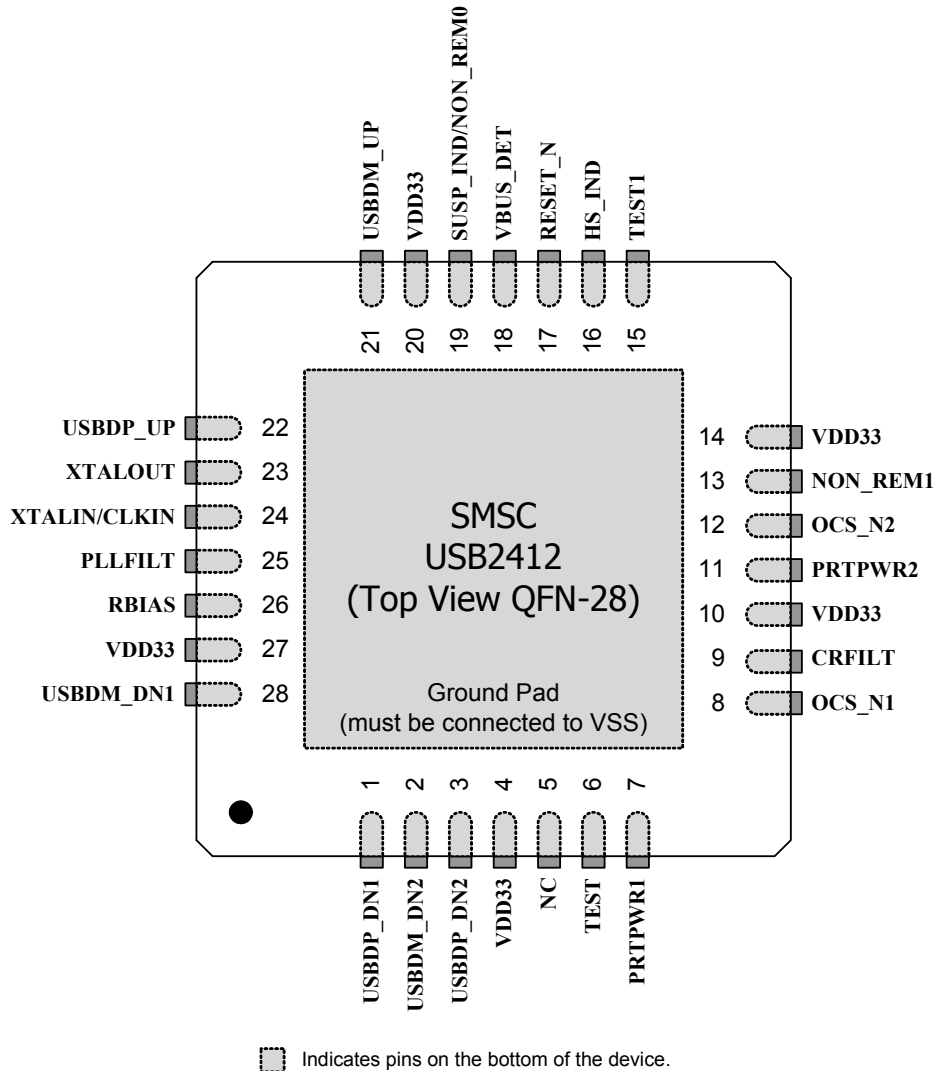

Figure 2.1 USB2412 28-Pin QFN

2.2 28-Pin Table

Table 2.1 USB2412 28-Pin Table

UPSTREAM USB 2.0 INTERFACES (3 PINS)			
USBDP_UP	USBDM_UP	VBUS_DET	
DOWNSTREAM 2-PORT USB 2.0 INTERFACES (9 PINS)			
USBDP_DN1	USBDM_DN1	USBDP_DN2	USBDM_DN2
PRT_PWR1	PRT_PWR2	OCS_N1	OCS_N2
RBIAS			
MISC (7 PINS)			
RESET_N	TEST	XTALIN / CLKIN	XTALOUT
NON_REM1	SUSP_IND / NON_REM0	HS_IND	
POWER, GROUND, AND NO CONNECTS (9 PINS)			
(5) VDD33	CRFILT	PLLFILT	VSS
NC			
TOTAL 28			

2.3 Pin Descriptions (Grouped by Function)

Table 2.2 USB2412 Pin Descriptions

PIN #	SYMBOL	BUFFER TYPE	DESCRIPTION
UPSTREAM USB 2.0 INTERFACES			
21 22	USBDM_UP USBDP_UP	IO-U	USB Bus Data: connect to the upstream USB bus data signals (host, port, or upstream hub).
18	VBUS_DET	I/O12	<p>Detect Upstream VBUS Power: detects the state of upstream VBUS power. The SMSC hub monitors VBUS_DET to determine when to assert the internal D+ pull-up resistor which signals a connect event.</p> <p>When designing a detachable hub, this pin should be connected to VBUS on the upstream port via a 2 to 1 voltage divider.</p> <p>For self-powered applications with a permanently attached host, this pin must be connected to a dedicated host control output, or connected to 3.3 V domain that powers the host.'</p> <p>According to Section 7.2.1 of the <i>USB 2.0 Specification 1.</i>, a downstream port can never provide power to its D+ or D- pull-up resistors unless the upstream port's VBUS is in the asserted (powered) state.</p> <p>VBUS_DET monitors the state of the upstream VBUS signal and will not pull-up the D+ resistor if VBUS is not active. If VBUS goes from an active to an inactive state (Not Powered), the hub will remove power from the D+ pull-up resistor within 10 seconds.</p>
DOWNSTREAM USB 2.0 INTERFACES			
1 3 28 2	USBDP_DN1 USBDP_DN2 USBDM_DN1 USBDM_DN2	IO-U	Hi-Speed USB Data: connect to the downstream USB peripheral devices attached to the hub's ports.
7 11	P RTPWR1 P RTPWR2	I/O12	USB Power Enable: enables power to USB peripheral devices that are downstream, where the hub supports active high power controllers only.
8 12	OCS_N1 OCS_N2	IPU	Over-Current Sense: input from external current monitor indicating an over-current condition. This pin contains an internal pull-up to the 3.3 V supply.
26	RBIAS	I-R	USB Transceiver Bias: a 12.0 kΩ (+/- 1%) resistor is attached from ground to this pin to set the transceiver's internal bias settings.
MISC			
13	NON_REM1	I/O	<p>Non-removable Port Strap Option: this pin is sampled (in conjunction with SUSP_IND/NON_REM0) at RESET_N negation to determine if ports [2:1] contain permanently attached (non-removable) devices:</p> <p>NON_REM[1:0] = 00: all ports are removable NON_REM[1:0] = 01: port 1 is non-removable NON_REM[1:0] = 10 and 11: ports 1 and 2 are non-removable</p> <p>See Section 2.5, "Strap Option Pins" for details.</p>

Table 2.2 USB2412 Pin Descriptions (continued)

PIN #	SYMBOL	BUFFER TYPE	DESCRIPTION
19	SUSP_IND /	I/O	Active/Suspend Status LED (suspend indicator): indicates the USB hub state. See Section 2.5, "Strap Option Pins" for details. NON_REM0 = 0: SUSP_IND is active high NON_REM0 = 1: SUSP_IND is active low negated = unconfigured, or configured and in USB suspend asserted = hub is configured and is active (i.e., not in suspend)
	NON_REM0		Non-removable Port Strap Option: this pin is sampled (in conjunction with NON_REM1) at RESET_N negation to determine if ports [2:1] contain permanently attached (non-removable) devices: NON_REM[1:0] = 00: all ports are removable NON_REM[1:0] = 01: port 1 is non-removable NON_REM[1:0] = 10 and 11: ports 1 and 2 are non-removable See Section 2.5, "Strap Option Pins" for details.
16	HS_IND	I/O12	Hi-Speed Upstream Port Indicator Note: An LED can be attached for visual indication. See Section 2.5, "Strap Option Pins" for details. When an LED is not used, this pin requires a 50 k Ω or higher resistor to ground. negated = the hub is connected at FS asserted = the hub is connected at HS
24	XTALIN	ICLKx	24 MHz Crystal Input: this pin connects to either one terminal of the crystal or to an external 24 MHz clock when a crystal is not used.
	CLKIN		External Clock Input: this pin connects to either one terminal of the crystal or to an external 24 MHz clock when a crystal is not used.
23	XTALOUT	OCLKx	24 MHz Crystal Output: this is the other terminal of the crystal circuit with 1.2 V p-p output and a weak (< 1mA) driving strength. When an external clock source is used to drive XTALIN/CLKIN , leave this pin unconnected, or use with appropriate caution.
6	TEST	IPD	Treat as a no connect pin or connect to ground. No trace or signal should be routed or attached to this pin.
17	RESET_N	IS	RESET Input: the system can reset the chip by driving this input low, where the minimum active low pulse is 1 μ s.
POWER, GROUND, and NO CONNECTS			
9	CRFILT		VDD Core Regulator Filter Capacitor: this pin can have up to 0.1 μ F low-ESR capacitor to VSS, or be left unconnected.
4 10 14 20 27	VDD33		3.3 V Power
25	PLLFILT		PLL Regulator Filter Capacitor: this pin can have up to 0.1 μ F low-ESR capacitor to VSS, or be left unconnected.
15	TEST1		This pin must be connected to VSS.

Table 2.2 USB2412 Pin Descriptions (continued)

PIN #	SYMBOL	BUFFER TYPE	DESCRIPTION
29	ePAD		Ground Pad/ePad: this pin must be connected to VSS for the device and must be tied to ground with multiple vias
5	NC		No Connect: no signal or trace should be routed or attached to these pins.

2.4 Buffer Type Descriptions

Table 2.3 Buffer Type Descriptions

BUFFER	DESCRIPTION
I/O	Input/Output
IPD	Input with internal weak pull-down resistor
IPU	Input with internal weak pull-up resistor
IS	Input with Schmitt trigger
I/O12	Input/Output buffer with 12 mA sink and 12 mA source
ICLKx	XTAL clock input
OCLKx	XTAL clock output
I-R	RBIAS
I/O-U	Analog Input/Output defined in USB specification

2.5 Strap Option Pins

The NON_REM[1:0] strap option pins can be enabled using the internal default configuration. The driver type of each strap pin is I/O (no internal pull-up or pull-down for the input function). [Figure 2.2](#) shows an example of Strap High and Strap Low configurations, where Strap High sets the strap option to a 1 and Strap Low sets the strap option value to 0. To use an external LED indicator, the options outlined in [Figure 2.3](#) should be implemented.

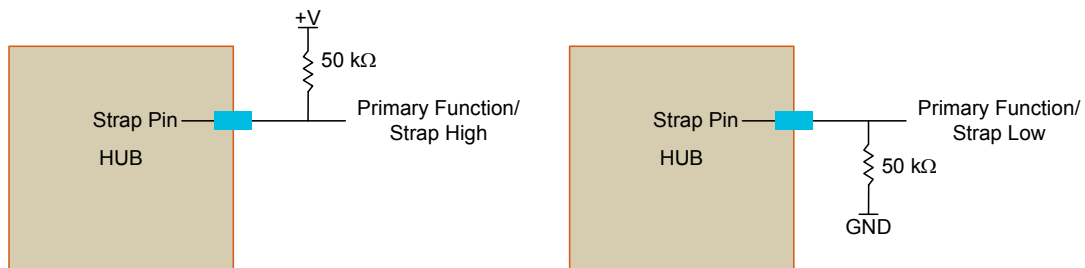
Figure 2.2 Non-Removable Pin Strap Example

Datasheet

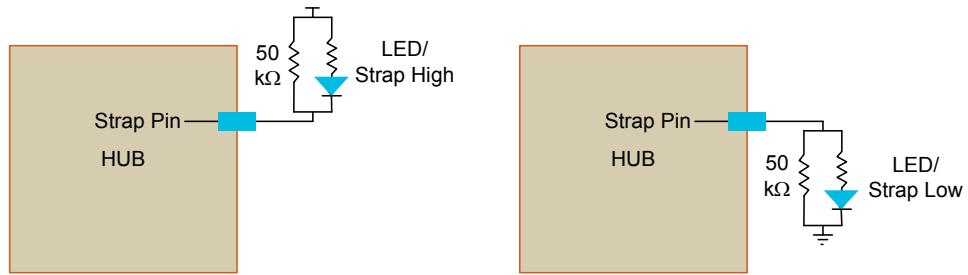

Figure 2.3 LED Pin Strap Example

Chapter 3 Internal Default Configuration

SMSC's USB 2.0 hub is fully compliant with the *USB Specification*¹. Refer to Chapter 10 (Hub Specification) for general details regarding hub operation and functionality.

The hub provides one Transaction Translator (TT) that is shared by both downstream ports (defined as Single-TT configuration). The TT contains 4 non-periodic buffers.

3.1 Hub Configuration

The USB2412 only supports internal defaults with the exception of the non-removable strap option (using **NON_REM[1:0]**). The hub internal default settings are as follows:

- Internal Default Configuration without over-rides
- Strap options enabled
- Self-powered operation enabled
- Individual power switching
- Individual over-current sensing

3.2 Reset

There are two different resets that the hub experiences. One is a hardware reset via **RESET_N** and the second is a USB Bus Reset.

3.2.1 External Hardware RESET_N

A valid hardware reset is defined as assertion of **RESET_N** for a minimum of 1 μ s after all power supplies are within operating range. While reset is asserted, the hub (and its associated external circuitry) consumes less than 500 μ A of current from the upstream USB power source.

Assertion of **RESET_N** causes the following:

1. All downstream ports are disabled, and **PRT_PWR** power to downstream devices is removed.
2. The PHYs are disabled, and the differential pairs will be in a high-impedance state.
3. All transactions immediately terminate; no states are saved.
4. All internal registers return to the default state (in most cases, 00h).
5. The external crystal oscillator is halted.
6. The PLL is halted.
7. The hub is "operational" 500 μ s after **RESET_N** is negated.

Datasheet

3.2.1.1 RESET_N

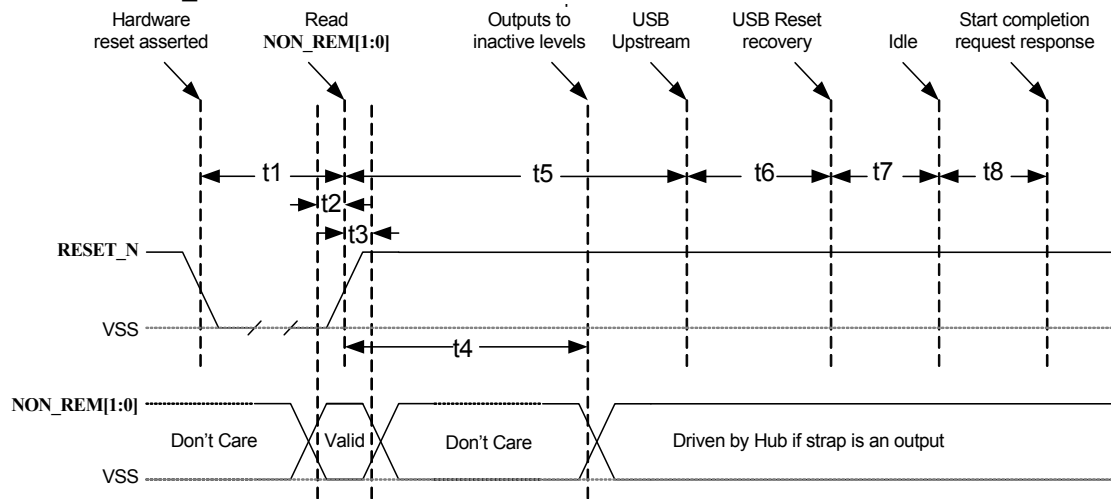

Figure 3.1 Reset_N Timing

Table 3.1 Reset_N Timing

NAME	DESCRIPTION	MIN	TYP	MAX	UNITS
t1	RESET_N asserted	1			μsec
t2	Strap setup time	16.7			nsec
t3	Strap hold time	16.7		1400	nsec
t4	Hub outputs driven to inactive logic states		1.5	2	μsec
t5	USB attach (See Note)			100	msec
t6	Host acknowledges attach and signals USB reset	100			msec
t7	USB idle		undefined		msec
t8	Completion time for requests (with or without data stage)			5	msec

Note: All power supplies must have reached the operating levels mandated in [Chapter 4, DC Parameters](#), prior to (or coincident with) the assertion of RESET_N.

3.2.2 USB Bus Reset

In response to the upstream port signaling a reset to the hub, the hub does the following:

1. Sets default address to 0.
2. Sets configuration to unconfigured.
3. Negates **PRT_PWR[2:1]** to all downstream ports.
4. Clears all TT buffers.
5. Moves device from suspended to active (if suspended).
6. Complies with Section 11.10 of the *USB 2.0 Specification* for behavior after completion of the reset sequence. The host then configures the hub and the hub's downstream port devices in accordance with the specification.

Note: The hub does not propagate the upstream USB reset to downstream devices.

Chapter 4 DC Parameters

4.1 Maximum Guaranteed Ratings

PARAMETER	SYMBOL	MIN	MAX	UNITS
Storage Temperature	T _{STOR}	-55	150	°C
Lead Temperature				°C
3.3 V supply voltage	VDD33 PLLFLT CRFLT		4.6	V
Voltage on any I/O pin		-0.5	5.5	V
Voltage on XTALIN		-0.5	4.0	V
Voltage on XTALOUT		-0.5	2.5	V

Note 4.1 Refer to JEDEC Specification J-STD-020D 5..

Note 4.2 Stresses above the specified parameters could cause permanent damage to the device. This is a stress rating only and functional operation of the device at any condition above those indicated in the operation sections of this specification is not implied.

Note 4.3 When powering this device from laboratory or system power supplies, it is important that the absolute maximum ratings not be exceeded or device failure can result. Some power supplies exhibit voltage spikes on their outputs when the AC power is switched on or off. In addition, voltage transients on the AC power line may appear on the DC output. When this possibility exists, it is suggested that a clamp circuit be used.

4.2 Operating Conditions

PARAMETER	SYMBOL	MIN	MAX	UNITS	COMMENTS
Operating Temperature	T _A	0	70	°C	Ambient temperature in still air.
3.3 V supply voltage	VDD33	3.0	3.6	V	
3.3 V supply rise time	t _{RT}	0	400	μs	See Figure 4.1
Voltage on any I/O pin		-0.3	5.5	V	If any 3.3 V supply voltage drops below 3.0 V, then the MAX becomes: (3.3 V supply voltage) + 0.5
Voltage on XTALIN		-0.3	VDD33	V	

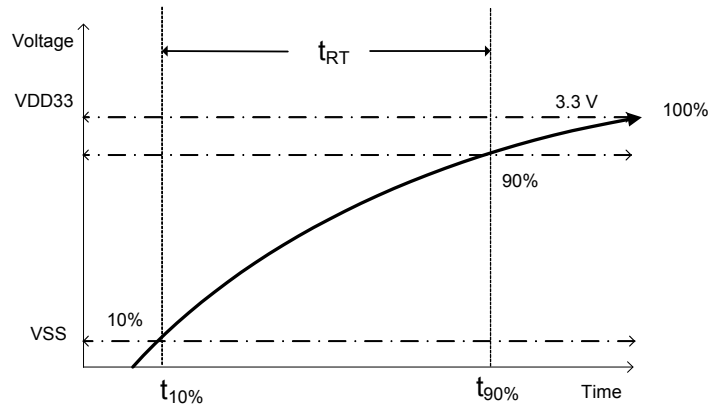

Figure 4.1 Supply Rise Time Model

Table 4.1 DC Electrical Characteristics

PARAMETER	SYMBOL	MIN	TYP	MAX	UNITS	COMMENTS
I, IS Type Input Buffer						
Low Input Level	V_{ILI}			0.8	V	TTL Levels
High Input Level	V_{IHI}	2.0			V	
Input Leakage	I_{IL}	-10		+10	μA	$V_{IN} = 0$ to VDD33
Hysteresis ('IS' Only)	V_{HYSI}	250		350	mV	
Input Buffer with Pull-Up (IPU)						
Low Input Level	V_{ILI}			0.8	V	TTL Levels
High Input Level	V_{IHI}	2.0			V	
Low Input Leakage	I_{ILL}	+35		+90	μA	$V_{IN} = 0$
High Input Leakage	I_{IHL}	-10		+10	μA	$V_{IN} = VDD33$
Input Buffer with Pull-Down (IPD)						
Low Input Level	V_{ILI}			0.8	V	TTL Levels
High Input Level	V_{IHI}	2.0			V	
Low Input Leakage	I_{ILL}	+10		-10	μA	$V_{IN} = 0$
High Input Leakage	I_{IHL}	-35		-90	μA	$V_{IN} = VDD33$
ICLK Input Buffer						
Low Input Level	V_{ILCK}			0.5	V	
High Input Level	V_{IHCK}	1.4			V	
Input Leakage	I_{IL}	-10		+10	μA	$V_{IN} = 0$ to VDD33

Table 4.1 DC Electrical Characteristics (continued)

PARAMETER	SYMBOL	MIN	TYP	MAX	UNITS	COMMENTS
O12, I/O12 &I/OSD12 Type Buffer						
Low Output Level	V_{OL}			0.4	V	$I_{OL} = 12 \text{ mA @ } V_{DD33} = 3.3 \text{ V}$ $I_{OH} = -12 \text{ mA @ } V_{DD33} = 3.3 \text{ V}$ $V_{IN} = 0 \text{ to } V_{DD33}$ (Note 4.1)
High Output Level	V_{OH}	2.4			V	
Output Leakage	I_{OL}	-10		+10	μA	
Hysteresis ('SD' pad only)	V_{HYSC}	250		350	mV	
Supply Current Unconfigured Hi-Speed Host	$I_{CCINTHS}$		40	45	mA	
Supply Current Unconfigured Full-Speed Host	$I_{CCINTFS}$		35	40	mA	
Supply Current Configured Hi-Speed Host, 1 downstream port	I_{HCH1}		60	65	mA	
Supply Current Configured Hi-Speed Host, each additional downstream port			1 port base + 25 mA	1 port base + 25 mA	mA	
Supply Current Configured Full-Speed Host, 1 downstream port	I_{FCC1}		45	50	mA	There is no additional current for additional ports.
Supply Current Configured Full-Speed Host, each additional downstream port			1 port base + 8 mA	1 port base + 8 mA	mA	
Supply Current Suspend	I_{CSBY}		475	1000	μA	All supplies combined
Supply Current Reset	I_{CRST}		550	1100	μA	All supplies combined

Note 4.4 Output leakage is measured with the current pins in high impedance.

Note 4.5 See *USB 2.0 Specification 1*. for USB DC electrical characteristics.

4.2.1 Pin Capacitance

Table 4.2 Pin Capacitance

PARAMETER	SYMBOL	LIMITS			UNIT	TEST CONDITION
		MIN	TYP	MAX		
Clock Input Capacitance	C_{XTAL}			6	pF	All pins except USB pins and the pins under the test tied to AC ground.
Input Capacitance	C_{IN}			6	pF	Capacitance $T_A = 25^\circ\text{C}$ $f_c = 1\text{ MHz}$ $V_{DD33} = 3.3\text{ V}$
Output Capacitance	C_{OUT}			6	pF	The maximum capacitance values include the full length of the pin pad. See the Y dimension in Figure 6.2 .

4.2.2 Package Thermal Specifications

Thermal parameters are measured or estimated for devices with the exposed pad soldered to thermal vias in a multilayer 2S2P PCB per JESD51. Thermal resistance is measured from the die to the ambient air.

Table 4.3 28-Pin QFN Package Thermal Parameters

PARAMETER	VELOCITY (meters/sec)	SYMBOL	VALUE	UNIT
Thermal Resistance	0	Θ_{JA}	40.3	$^\circ\text{C/W}$
	1		35.2	
Junction-to-Top-of-Package	0	Ψ_{JT}	0.5	$^\circ\text{C/W}$
	1		0.6	

Chapter 5 AC Specifications

5.1 Oscillator/Crystal

Parallel Resonant, Fundamental Mode, 24 MHz \pm 350 ppm.

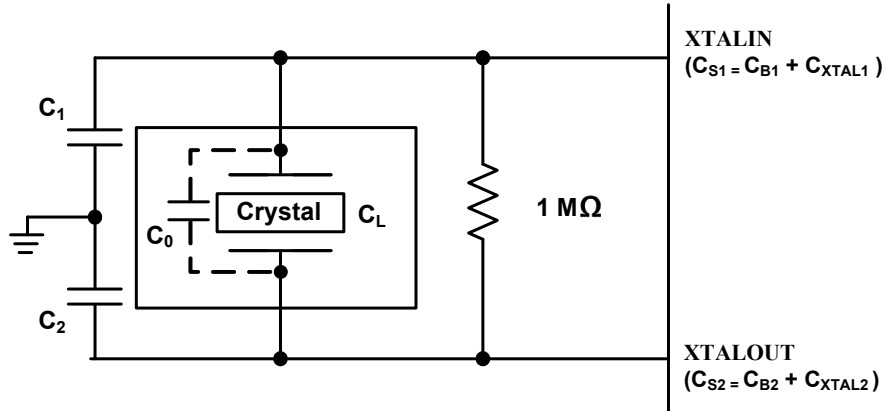

Figure 5.1 Typical Crystal Circuit

Table 5.1 Crystal Circuit Legend

SYMBOL	DESCRIPTION	IN ACCORDANCE WITH
C_0	Crystal shunt capacitance	Crystal manufacturer's specification (See Note 5.1)
C_L	Crystal load capacitance	
C_B	Total board or trace capacitance	OEM board design
C_S	Stray capacitance	SMSC IC and OEM board design
C_{XTAL}	XTAL pin input capacitance	SMSC IC
C_1	Load capacitors installed on OEM board	Calculated values based on Figure 5.2 , "Formula to Find the Value of C_1 and C_2 " (See Note 5.2)
C_2		

$$C_1 = 2 \times (C_L - C_0) - C_{S1}$$

$$C_2 = 2 \times (C_L - C_0) - C_{S2}$$

Figure 5.2 Formula to Find the Value of C_1 and C_2

Note 5.1 C_0 is usually included (subtracted by the crystal manufacturer) in the specification for C_L and should be set to 0 for use in the calculation of the capacitance formulas in [Figure 5.2](#), "Formula to Find the Value of C_1 and C_2 ". However, the PCB itself may present a parasitic capacitance between **XTALIN** and **XTALOUT**. For an accurate calculation of C_1 and C_2 , take the parasitic capacitance between traces **XTALIN** and **XTALOUT** into account.

Note 5.2 Each of these capacitance values is typically approximately 18 pF.

5.2 External Clock

50% Duty cycle $\pm 10\%$, 24 MHz ± 350 ppm, Jitter < 100 ps rms.

The external clock is recommended to conform to the signaling level designated in the JESD76-2 specification on 1.2 V CMOS Logic. **XTALOUT** should be treated as a no connect.

5.2.1 USB 2.0

The SMSC hub conforms to all voltage, power, and timing characteristics and specifications as set forth in the *USB 2.0 Specification 1*. See the *USB Specification* for more information.

Chapter 6 Package Outline

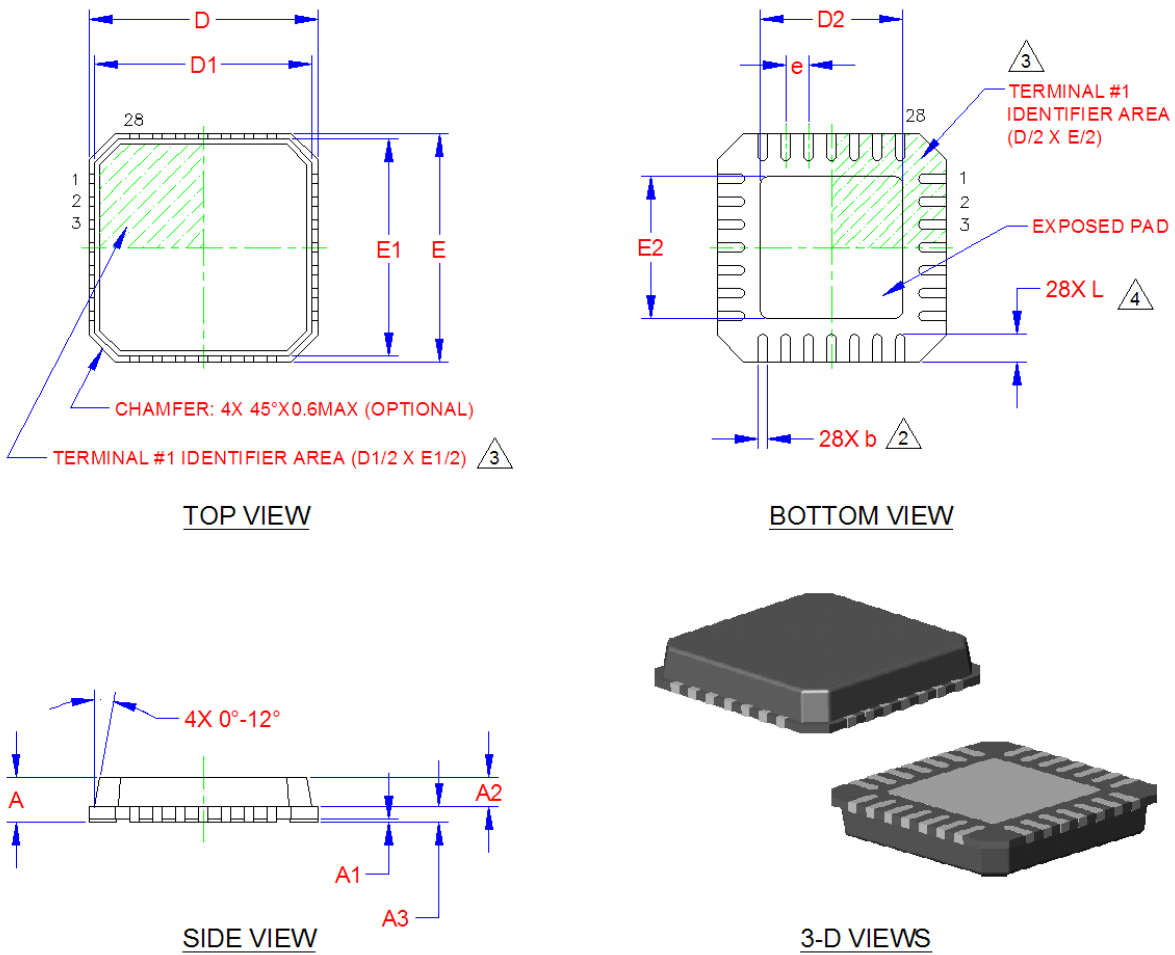

Figure 6.1 USB2412 28-Pin QFN Package Outline (5x5 mm Body, 0.5 Pitch, 3.1 ePad)

Table 6.1 Package Parameters

	MIN	NOMINAL	MAX	NOTE	REMARKS
A	0.80	0.85	1.00	-	Overall Package Height
A1	0	0.02	0.05	-	Standoff
A2	0.60	-	0.80	-	Mold Cap Thickness
D/E	4.90	5.00	5.10	-	X/Y Overall Body Size
D1/E1	4.55	4.75	4.95	-	X/Y Mold Cap Size
D2/E2	3.00	3.10	3.20	-	X/Y Exposed Pad Size
L	0.30	0.40	0.50	-	Terminal Length
b	0.18	0.25	0.30	2	Terminal Width
K	0.45	0.55	-	-	Terminal to ePad Clearance
e	0.50 BSC			-	Terminal Pitch

Notes:

- All dimensions are in millimeters.
- Position tolerance of each terminal and exposed pad is ± 0.05 mm at maximum material condition. Instances of dimension "b" apply to plated terminals and is measured between 0.15 and 0.33 mm from the terminal tip.
- Details of terminal #1 identifier are optional. However, they must be located within the area indicated.
- Coplanarity zone applies to exposed pad and terminals.

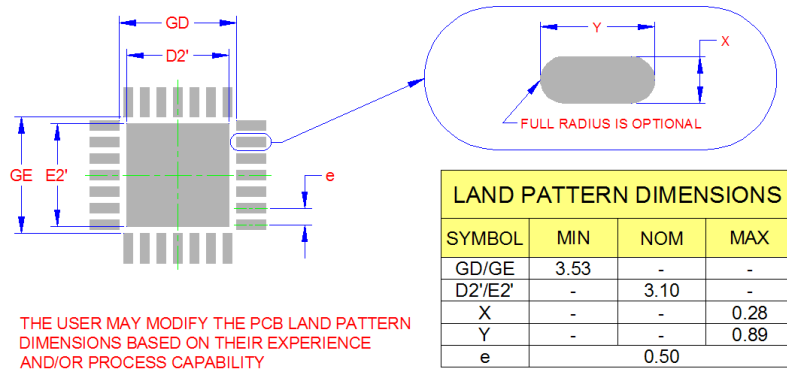

Figure 6.2 Recommended Printed Circuit Board (PCB) Land Pattern

6.1 Tape and Reel Specification

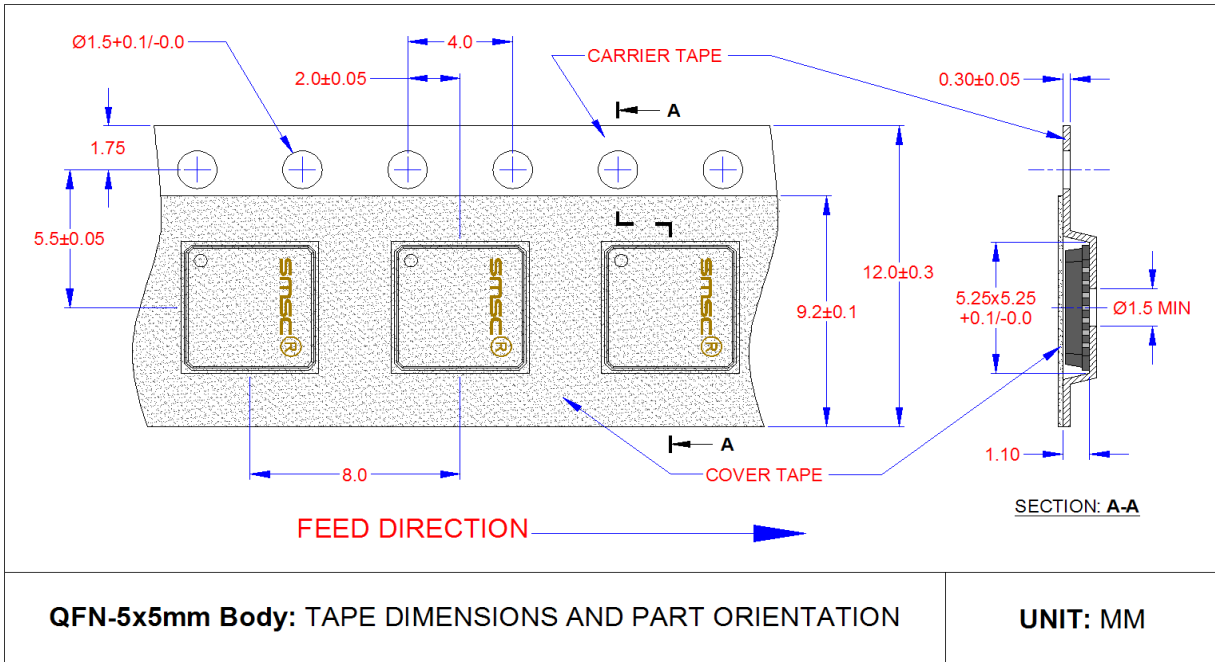

Figure 6.3 28-Pin Package Tape Dimensions and Part Orientation (mm)

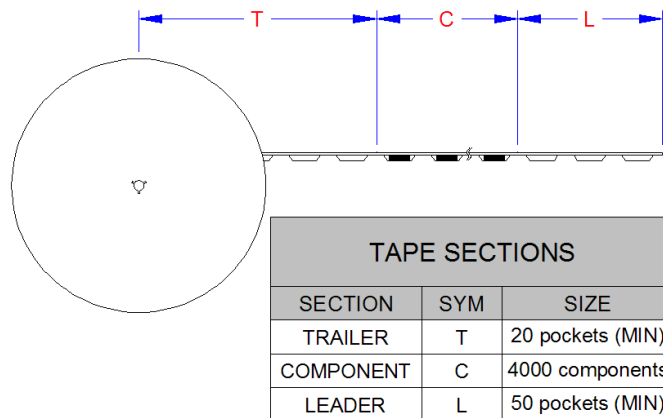
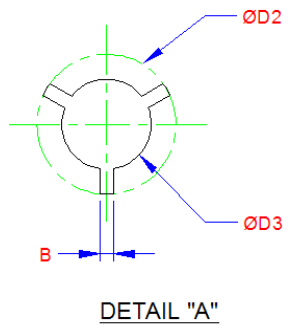
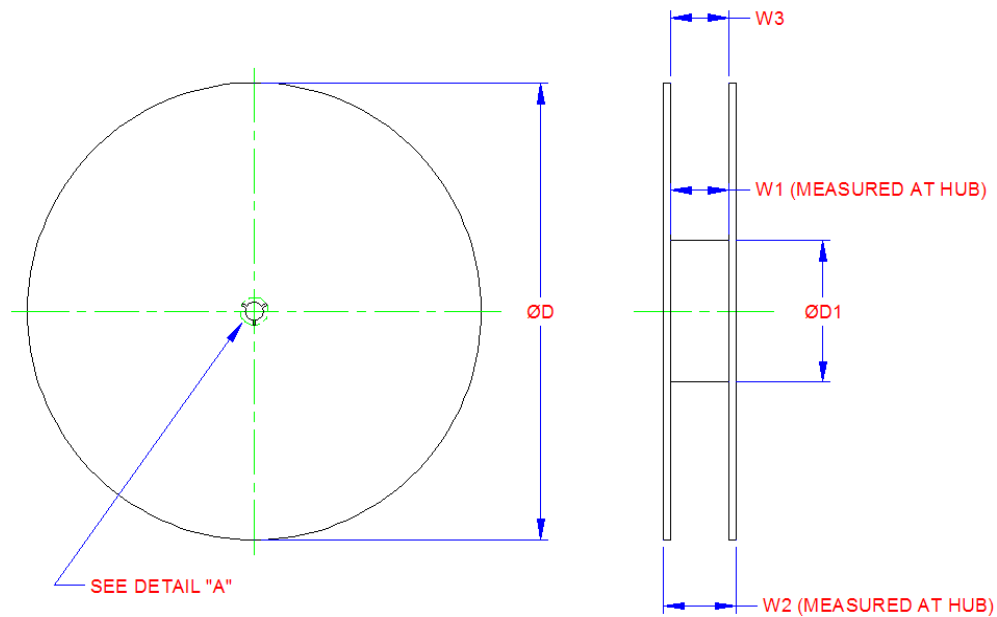

Figure 6.4 28-Pin Package Tape Length and Part Quantity



REEL DIMs for 12mm CARRIER TAPE			
PART	FEATURE	SYM	SIZE (mm)
FLANGE	DIAMETER	D	330 (+0.25/-4.00)
	SPACE between FLANGES	W1	12.4 (+2.0/-0.0)
	OVERALL WITH	W2	18.4 (MAX)
	MIN SPACE "W1" AT FLANGE EDGE	W3	12.3 (MIN)
HUB	OUTER DIAMETER	D1	102 REF
	KEY SLIT DIAMETER	D2	20.2 (MIN)
	ARBOR HOLE DIAMETER	D3	13.0 (+0.5/-0.2)
	KEY SLIT WIDTH	B	2.0 (±0.5)

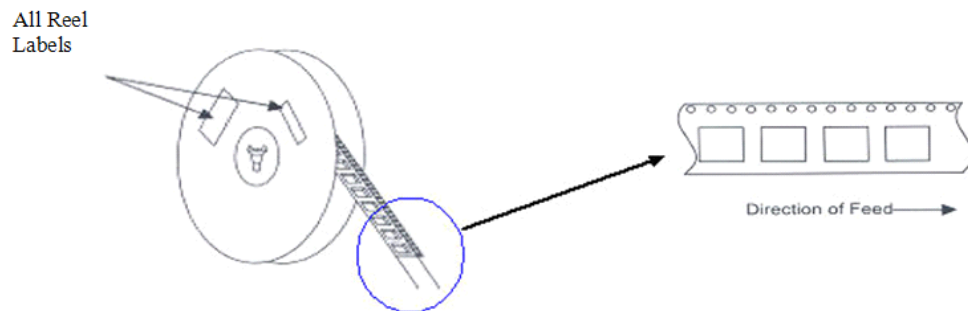

Figure 6.5 Package Reel Specifications

Appendix A (Acronyms)

I²C[®] :	Inter-Integrated Circuit ¹
OCS :	Over-Current Sense
PCB :	Printed Circuit Board
PHY :	Physical Layer
PLL :	Phase-Locked Loop
QFN :	Quad Flat No Leads
RoHS :	Restriction of Hazardous Substances Directive
SCL :	Serial Clock
SIE :	Serial Interface Engine
SMBus :	System Management Bus
TT :	Transaction Translator

¹.I²C is a registered trademark of Philips Corporation.

Appendix B References

1. Universal Serial Bus Specification, Version 2.0, April 27, 2000 (12/7/2000 and 5/28/2002 Errata)
USB Implementers Forum, Inc. <http://www.usb.org>
2. I²C-Bus Specification Version 1.1
NXP (formerly a division of Philips). <http://www.nxp.com>
3. System Management Bus Specification, version 1.0
SMBus. <http://smbus.org/specs/>
4. MicroChip 24AA02/24LC02B (Revision C)
Microchip Technology Inc. <http://www.microchip.com/>
5. JEDEC Specifications: JESD76-2 (June 2001) and J-STD-020D.1 (March 2008)
JEDEC Global Standards for the Microelectronics Industry.
<http://www.jedec.org/standards-documents>

Компания «Life Electronics» занимается поставками электронных компонентов импортного и отечественного производства от производителей и со складов крупных дистрибьюторов Европы, Америки и Азии.

С конца 2013 года компания активно расширяет линейку поставок компонентов по направлению коаксиальный кабель, кварцевые генераторы и конденсаторы (керамические, пленочные, электролитические), за счёт заключения дистрибьюторских договоров

Мы предлагаем:

- Конкурентоспособные цены и скидки постоянным клиентам.
- Специальные условия для постоянных клиентов.
- Подбор аналогов.
- Поставку компонентов в любых объемах, удовлетворяющих вашим потребностям.
- Приемлемые сроки поставки, возможна ускоренная поставка.
- Доставку товара в любую точку России и стран СНГ.
- Комплексную поставку.
- Работу по проектам и поставку образцов.
- Формирование склада под заказчика.
- Сертификаты соответствия на поставляемую продукцию (по желанию клиента).
- Тестирование поставляемой продукции.
- Поставку компонентов, требующих военную и космическую приемку.
- Входной контроль качества.
- Наличие сертификата ISO.

В составе нашей компании организован Конструкторский отдел, призванный помогать разработчикам, и инженерам.

Конструкторский отдел помогает осуществить:

- Регистрацию проекта у производителя компонентов.
- Техническую поддержку проекта.
- Защиту от снятия компонента с производства.
- Оценку стоимости проекта по компонентам.
- Изготовление тестовой платы монтаж и пусконаладочные работы.



Тел: +7 (812) 336 43 04 (многоканальный)

Email: org@lifeelectronics.ru