

M0216MD-162MDBR2-J

Vacuum Fluorescent Display Module

RoHS Compliant

Newhaven Display International, Inc.

2511 Technology Drive, Suite 101

Elgin IL, 60124

Ph: 847-844-8795

Fax: 847-844-8796

www.newhavendisplay.com

nhtech@newhavendisplay.com

nhsales@newhavendisplay.com

Document Revision History

Revision	Date	Description	Changed by
0	5/4/2001	Initial Release	-
1	3/18/2002	Eliminate exhaust from glass design	-
2	11/19/2005	Convert to RoHS Pb-free components	-
3	2/24/2006	Sumida 134752B –EOL, convert to new power supply 134752C. Current consumption increases from (170mA TYP ~230mA MAX) to (350mA TYP ~ 400mA MAX)	-
4	5/25/2010	User Guide Reformat	BE
5	6/8/2010	High level input current added, controller name added	BE

1. SCOPE

This specification applies to VFD module (Model No: M0216MD-162MDBR2-J).

2. FEATURES

- a. Since a DC/DC converter is used, only +5Vdc power source is required to operate the module.
- b. High quality display and luminance
- c. ASCII and Japanese characters (CG-ROM font).

3. GENERAL DESCRIPTIONS

- a. This specification becomes effective after being approved by the purchaser.
- b. When any conflict is found in the specification, appropriate action should be taken upon agreement of both parties.
- c. The expected necessary service parts should be arranged by the customer before the completion of production.

4. PRODUCT SPECIFICATIONS

4.1 Type

Table 1

Type	M0216MD-162MDBR2-J
Digit Format	5x7 Dot with Cursor
Controller	PT6314

4.2 Outer Dimensions (See Fig 7 for details)

Table 2

Parameter		Specifications	Unit
Outer Dimensions	Width	122.0 +- 1.0	mm
	Height	44.0 +- 1.0	mm
	Thickness	20.2 Max	mm

4.3 Specifications of the Display Panel

Table 3

Parameter	Specification	Unit
Display Size (W*H)	82.7*19	mm
Number of Digit	16 Digits*2 Line	-
Character Size (W*H)	9.22*3.85	mm
Character Pitch	3.85*8.03	mm
Dot Size	0.89*0.53	mm
Display Color	Blue-Green (505 nm)	-

4.4 Environment Conditions

Table 4

Parameter	Symbol	Min.	Max.	Unit
Operating Temperature	Topr	-40	+85	°C
Storage Temperature	Tstg	-50	+95	°C
Humidity (Operating)	Hopr	0	85	%
Humidity (Non-operating)	Hstg	0	90	%
Vibration (10 ~ 55 Hz)	-	-	4	G
Shock	-	-	40	G

4.5 Absolute Maximum Ratings

Table 5

Parameter	Symbol	Min.	Max.	Unit
Supply Voltage	Vcc	-0.5	5.5	Vdc
Input Signal Voltage	Vis	-0.5	5.5	Vdc

4.6 Recommend Operating Conditions

Table 6

Parameter	Symbol	Min.	Typ.	Max.	Unit
Supply Voltage	Vcc	4.5	5.0	5.5	Vdc.
Signal (Logic) Input Voltage	Vis	0	-	Vcc	Vdc

4.7 DC Characteristics (Ta=+25°C, Vcc=+5.0Vdc)

Table 7

Parameter	Symbol	Min.	Typ.	Max.	Unit
Supply Current	Icc	-	350	400	mA
High Level input current	IiH	20	-	500	μA
Logic Input Voltage	"H" Level	Vih	0.7*Vcc	-	Vdc
	"L" Level	Vil	-	0.3*Vcc	Vdc
Luminance	L	100	200	-	Ft-L (cd/m2)

4.8 Timing Chart and AC Characteristics

4.8.1 Power-on Reset and /or RESET Signal Timing

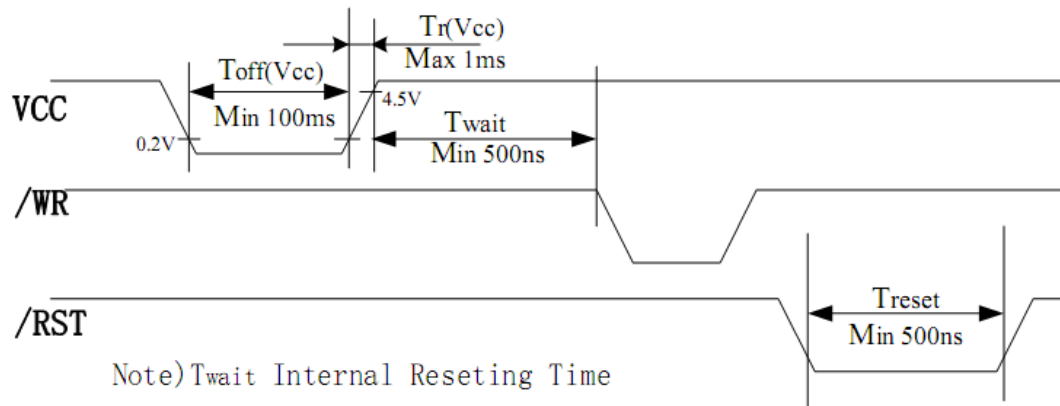

Fig-1 Power-on Reset and RESET signal Timing

4.8.2 I80 type CPU bus write in Timing

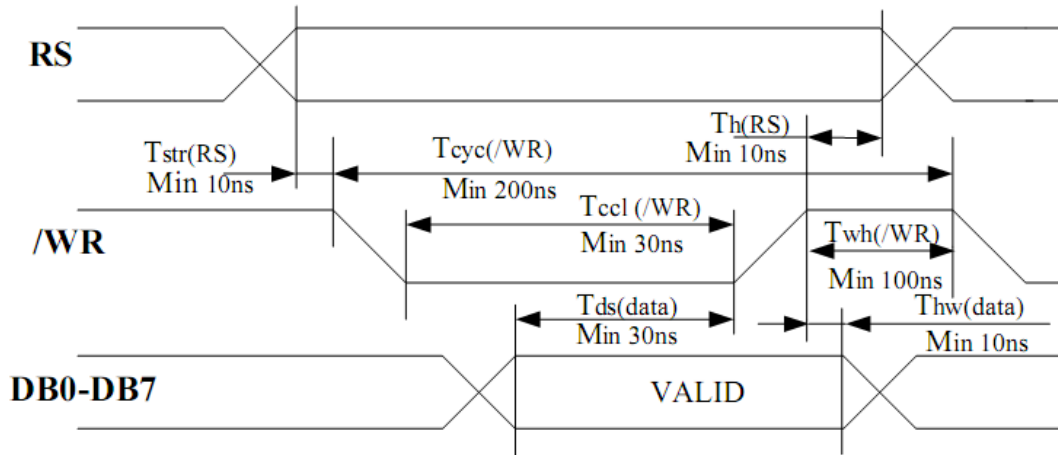

Fig -2 Data write-in Timing Diagram

4.8.3 i80 type CPU bus read-out Timing

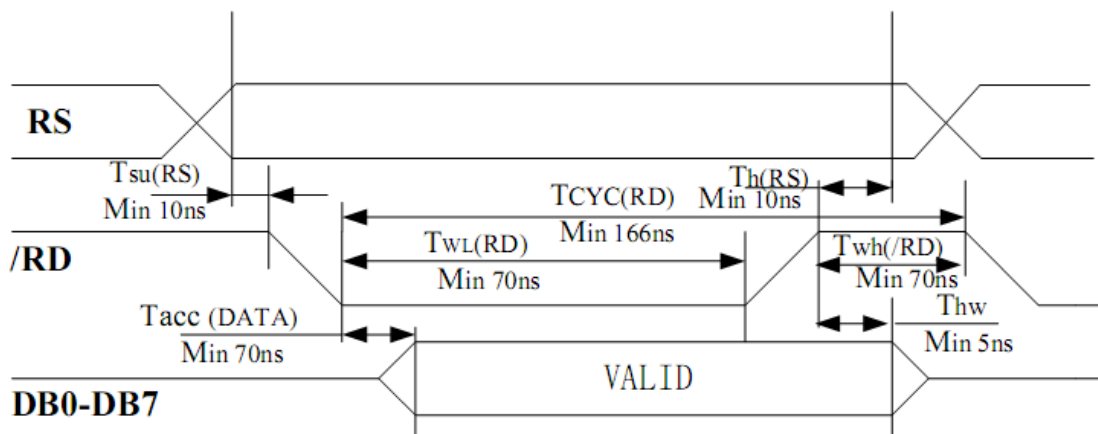

Fig-3 Dada Read-out Timing Diagram (i80 bus interface)

4.8.4 M68 type CPU bus write in timing

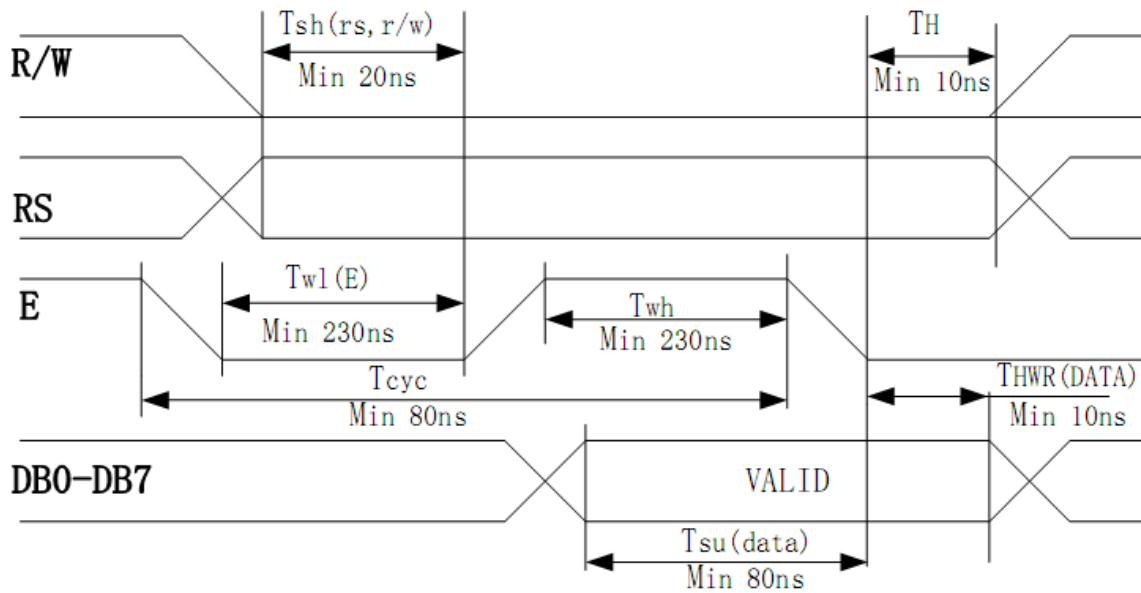

Fig-4 Data write-in Timing Diagram(M68 bus interface)

4.8.5 M68 type CPU bus read-out Timing

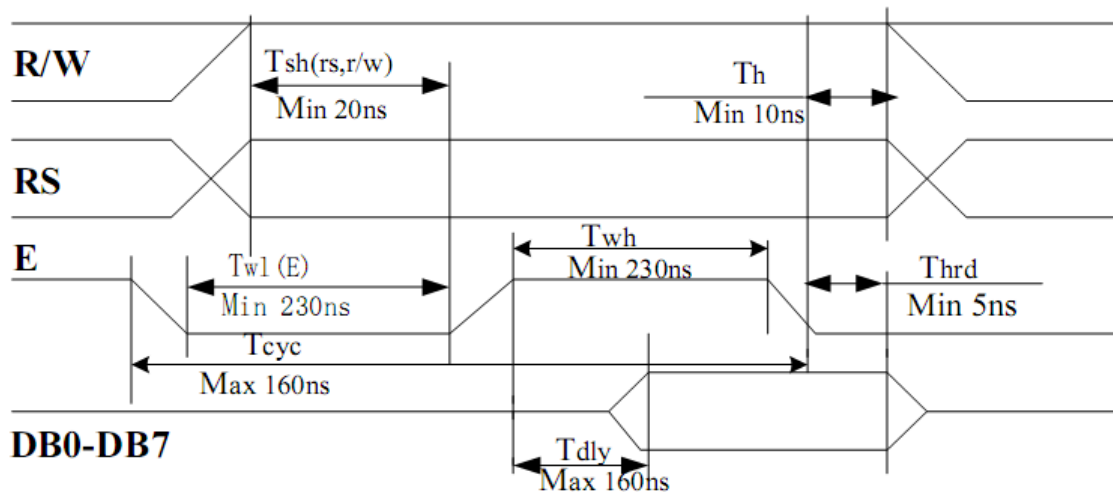
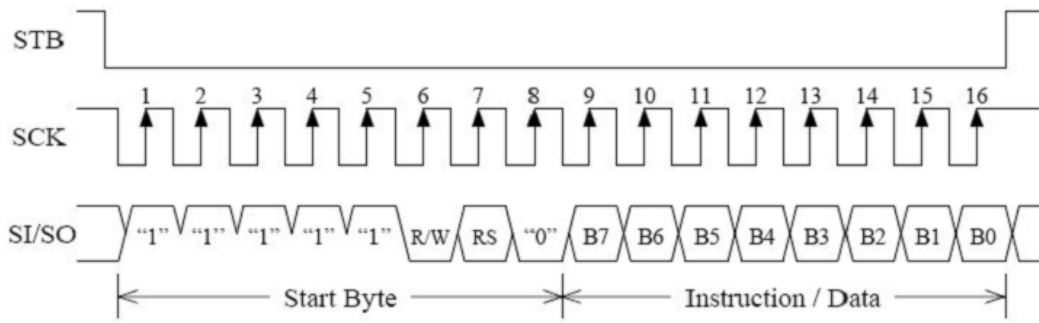

Fig-5 Data read-out Timing Diagram (M68)

4.8.6 SYNCHRONOUS SERIAL INTERFACE MODE

In the synchronous serial interface mode, instructions and data are sent between the host and the module using 8-bit bytes. Two bytes are required per read/write cycle and are transmitted MSB first. The start byte contains 5 high bits, the Read/Write (R/W) control bit, the Register Select (RS) control bit, and a low bit. The following byte contains the instruction/data bits. The R/W bit determines whether the cycle is a read (high) or a write (low) cycle. The RS bit is used to identify the second byte as an instruction (low) or data (high). This mode uses the Strobe (STB) control signal, Serial Clock (SCK) input, and Serial I/O (SI/SO) line to transfer information. In a write cycle, bits are clocked into the module on the rising edge of SCK. In a read cycle, bits in the start byte are clocked into the module on the rising edge of SCK. After the minimum wait time, each bit in the instruction/data byte can be read from the module after each falling edge of SCK. Each read/write cycle begins on the falling edge of STB and ends on the rising edge. To be a valid read/write cycle, the STB must go high at the end of the cycle.



Typical Synchronous Serial Interface Write Cycle

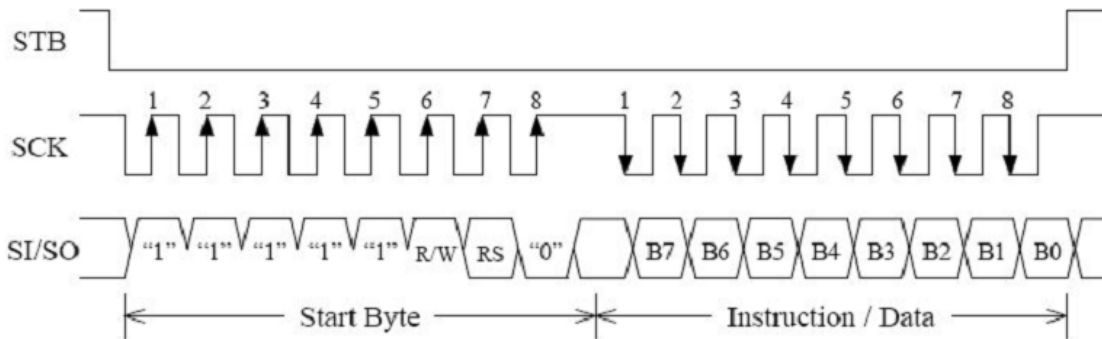

Typical Synchronous Serial Interface Read Cycle

4.8.7 14pin Connector - Fourteen (14) of through holes are prepared for power supply and data communications. A connector or pins may be able to soldered to the holes.

Table_8

Pin No.	Serial	Parallel (Intel)	Parallel (Motorola)	Pin No.	Serial	Parallel (Intel)	Parallel (Motorola)
1	GND	GND	GND	2	Vcc	Vcc	Vcc
3	SI/SO	NC	NC	4	STB	RS	RS
5	NC	WR/	R/W	6	SCK	RD/	E
7	NC	DB0	DB0	8	NC	DB1	DB1
9	NC	DB2	DB2	10	NC	DB3	DB3
11	NC	DB4	DB4	12	NC	DB5	DB5
13	NC	DB6	DB6	14	NC	DB7	DB7

NC = No Connection

4.8.7 Jumper links

Some jumper are prepared on the PCB board, to set operating mode of the display module. A soldering iron is required to short jumper.

When jumper link JP2 is soldered, these inputs change to i80 series CPU control lines. Pin 5 = /WR Pin 6 = /RD . (#Interface M68/i80)

This is normally open circuit. If pads JP1.1 and JP1.2 are linked. Pin 3 = /Reset. (Pin 3 (Fnc) Input)

4.8.8 Mechanical Drawing

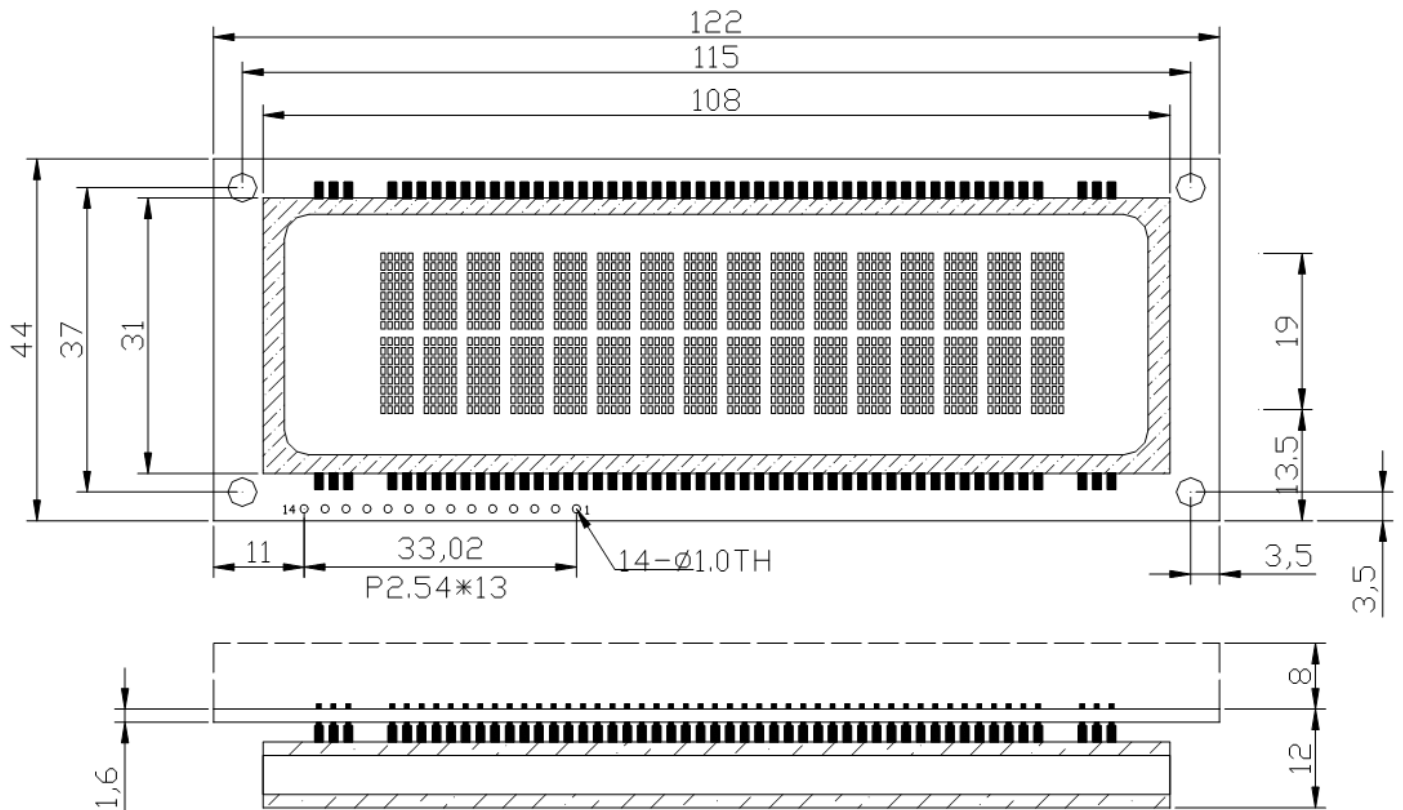

Fig 5

1. FUNCTION DESCRIPTIONS

1.1 Registers in VFD Controller

The VFD controller has two 8-bit registers, an instruction register (IR) and a data register (DR). IR stores instruction codes, such as display clear and cursor shift, and address information for DD-RAM and CG-RAM. The IR can only be written from the host MPU. DR temporarily stores data to be written into DD-RAM or CG-RAM and temporarily stores data to be read from DD-RAM or CG-RAM by an internal operation. The DR is also used for data storage when reading data from DD-RAM or CG-RAM. When address information is written into the IR, data is read and then stored into the DR from DD-RAM or CG-RAM by internal operation. Data transfer between MPU is then completed when the MPU reads the DR. After the read, data in DD-RAM or CG-RAM at the next address is sent to the DFR for the next read from the MPU. By the register selector (RS) signal, these two registers can be selected (See Table 8).

Table-8 Register Selection

RS	M68	i80		Operation
	R/W	/RD	/WR	
0	0	1	0	IR write as an internal operation (display clear, etc.)
0	1	0	1	Read busy flag (DB7) and address counter (DB0 to DB6)
1	0	1	0	DR write as an internal operation (DR to DDRAM or CGRAM)
1	1	0	1	DR read as an internal operation (DDRAM or CGRAM to DR)

5.1.1 Busy Flag (BF)

When the busy flag is 1, the controller is in the internal operation mode, and the next instruction will not be accepted. When RS = 0 and R/W = 1 (Table-8), the busy flag is output to DB7. The next instruction must be written after ensuring that the busy flag is 0.

5.1.2 Address Counter (ACC)

The address counter (ACC) assigns addresses to both DD-RAM and CG-RAM. When an address of an instruction is written into the IR, the address information is sent from the IR to the ACC. Selection of either DD-RAM or CG-RAM is also determined concurrently by the instruction. After writing into (reading from) DD-RAM or CG-RAM, the ACC is automatically incremented by 1 (decremented by 1). The ACC contents are then output to DB0 to DB6 when RS = 0 and R/W = 1 (See Table-8).

5.1.3 Display Data RAM (DD-RAM)

Display data RAM (DD-RAM) stores display data represented in 8-bit character codes. The area in DD-RAM that is not used for display can be used as general data RAM. See Table_9 for the relationships between DD-RAM addresses and positions on the VFD.

Table_9 Relation between Digit Position and DD-RAM data

	Left End	2nd Column	3rd Column	19th Column	Right End
1st Row	00 Hex	01 Hex	02 Hex	12 Hex	13 Hex
2nd Row	40 Hex	41 Hex	42 Hex	52 Hex	53 Hex

5.1.4 Character Generator ROM (CG-ROM)

The character generator ROM (CG-ROM) generates character patterns of 5X7 dots from 8-bit character codes (Table-10). It can generate 240 kinds of 5X7 dot character patterns. The character fonts are shown on the following page. The character codes 00H to 0FH are allocated to the CG-RAM

5.1.5 Character Generator RAM (CG-RAM)

In the character generator RAM (CG-RAM), the user can rewrite character patterns by program. For 5X7 dots and cursor, eight character patterns can be written. Write into DD-RAM the character codes at the addresses shown as the left column of Table-10 to show the character patterns stored in CG-RAM. See Table-11 for the relationship between CG-RAM addresses and data and display patterns and refer to Fig-10 for dot assignment of VFD. Areas that are not used for display can be used as general data RAM.

1	2	3	4	5
6	7	8	9	10
11	12	13	14	15
16	17	18	19	20
21	22	23	24	25
26	27	28	29	30
31	32	33	34	35
36				

Fig-10 Dot Assignment

Table-10 Characters Font Table (CG-ROM)and CG-RAM codes

Upper bits		DB7	0	0	0	0	0	0	0	1	1	1	1	1	1	1				
		DB6	0	0	0	0	1	1	1	1	0	0	0	1	1	1	1			
Lower bits		DB5	0	0	1	1	0	0	1	1	0	0	1	1	0	1				
		DB4	0	1	0	1	0	1	0	1	0	1	0	1	0	1	0			
DB0	DB1	DB2	DB3		0	1	2	3	4	5	6	7	8	9	A	B	C	D	E	F
0	0	0	0	0	CG-RAM (1)			0	0	P	'	P	Ä	Æ		-	タ	ミ	α	ρ
0	0	0	1	1	CG-RAM (2)		!	1	A	Q	a	q	À	æ	◻	ア	チ	△	ä	q
0	0	1	0	2	CG-RAM (3)	■	"	2	B	R	b	r	Â	£	「	イ	ツ	×	ß	θ
0	0	1	1	3	CG-RAM (4)	■	#	3	C	S	c	s	á	℞	」	ウ	テ	ε	ε	∞
0	1	0	0	4	CG-RAM (5)	■	\$	4	D	T	d	t	à	●	、	イ	ト	ト	μ	Ω
0	1	0	1	5	CG-RAM (6)	■	%	5	E	U	e	u	E	o	・	オ	ナ	1	∞	ü
0	1	1	0	6	CG-RAM (7)	■	&	6	F	V	f	v	ö	✦	ヲ	カ	ニ	ヨ	ρ	Σ
0	1	1	1	7	CG-RAM (8)	■	'	7	G	W	g	w	ö	◇	ア	キ	ヌ	ラ	g	π
1	0	0	0	8	CG-RAM (1)		(8	H	X	h	x	ø	!	イ	ク	ネ	リ	μ	∞
1	0	0	1	9	CG-RAM (2)	♪)	9	I	Y	i	y	ø	ç	ウ	ケ	ル	'	y	
1	0	1	0	A	CG-RAM (3)	¢	*	:	J	Z	j	z	ü	△	エ	コ	ハ	レ	j	¥
1	0	1	1	B	CG-RAM (4)	£	+	;	K	[k	(ü	≤	オ	サ	ヒ	o	*	斤
1	1	0	0	C	CG-RAM (5)	▼	,	<	L	¥	l		\	≥	カ	シ	フ	ワ	φ	円
1	1	0	1	D	CG-RAM (6)	†	-	=	M]	m)	≠	€	ユ	ヌ	ハ	ン	ト	÷
1	1	1	0	E	CG-RAM (7)	‡	.	>	N	^	n	‡	≈	↑	ヨ	セ	ホ	°	ñ	
1	1	1	1	F	CG-RAM (8)	▲	/	?	O	_	o	←	§	↓	ッ	ソ	マ	°	ö	■

Table-11 Relationship between CG-RAM Addresses, Character Codes(DD-RAM) and 5*7 (with Cursor) Dot Character Patterns (CG-RAM data)

Character Codes (DD-RAM data)								CG-RAM Address						Character Patterns (CG-RAM data)							
D	D	D	D	D	D	D	D	A	A	A	A	A	A	D	D	D	D	D	D	D	D
7	6	5	4	3	2	1	0	5	4	3	2	1	0	7	6	5	4	3	2	1	0
0	0	0	0	..	0	0	0	0	0	0	0	0	0	..	1	2	3	4	5		
											0	0	1	..	6	7	8	9	10		
											0	1	0	..	11	12	13	14	15		
											0	1	1	..	16	17	18	19	20		
											1	0	0	..	21	22	23	24	25		
											1	0	1	..	26	27	28	29	30		
											1	1	0	..	31	32	33	34	35		
											1	1	1	..	36		
0	0	0	0	..	0	0	1	0	0	1	0	0	0	..	1	2	3	4	5		
											0	0	1	..	6	7	8	9	10		
											0	1	0	..	11	12	13	14	15		
											0	1	1	..	16	17	18	19	20		
											1	0	0	..	21	22	23	24	25		
											1	0	1	..	26	27	28	29	30		
											1	1	0	..	31	32	33	34	35		
											1	1	1	..	36		
0	0	0	0	..	0	1	0	0	1	0	0	0	0	..	1	2	3	4	5		
											0	0	1	..	6	7	8	9	10		
											0	1	0	..	11	12	13	14	15		
											0	1	1	..	16	17	18	19	..		
0	0	0	0	..	1	1	1	1	1	1	1	0	1	..	26	27	28	29	30		
											1	1	0	..	31	32	33	34	35		
											1	1	1	..	36		

Character Pattern(1)

Cursor position

Character Pattern(2)

Cursor position

- Notes:
1. Character code bits 0 to 2 correspond to CG-RAM address bits 3 to 5 (3 bits : 8 types).
 2. CG-RAM address bits 0 to 2 designate the character pattern line position. The 8th line is the cursor position and its display is formed by a logical OR with the cursor. Maintain the 8th line data, corresponding to the cursor display position, at 0 as the cursor display.
If bit 4 of the 8th line data is 1, 1 bit will light up the cursor regardless of the cursor presence.
 3. Character pattern row positions correspond to CG-RAM data bits 0 to 4 (bit 4 being at the left).
 4. As shown Table-11, CG-RAM character patterns are selected when character code bits 4 to 7 are all 0. However, since character code bit 3 has no effect, the R display example above can be selected by either character code 00H or 08H.
 5. 1 for CG-RAM data corresponds to display selection and 0 to non-selection.
- ".." Indicates no effect (Don't care)

5.2 Interfacing to the MPU

This VFD module can interface in either two 4-bit operations or one 8-bit operation, thus allowing interfacing with 4- or 8-bit MPUs.

* For 4-bit interface data, only four bus lines (DB4 to DB7) are used for transfer. When to use 4-bit parallel data transfer, DB0 to DB3 keep "H" or "L". The data transfer between the VFD module and the MPU is completed after the 4-bit data has been transferred twice. As for the order of data transfer the four high order bits (for 8-bit operation, DB4 to DB7) are transferred before the four low order bits (for 8-bit operation, DB0 to DB3).

The busy flag (BF) are performed before transferring the higher 4 bits. BF checks are not required before transferring the lower 4 bits.

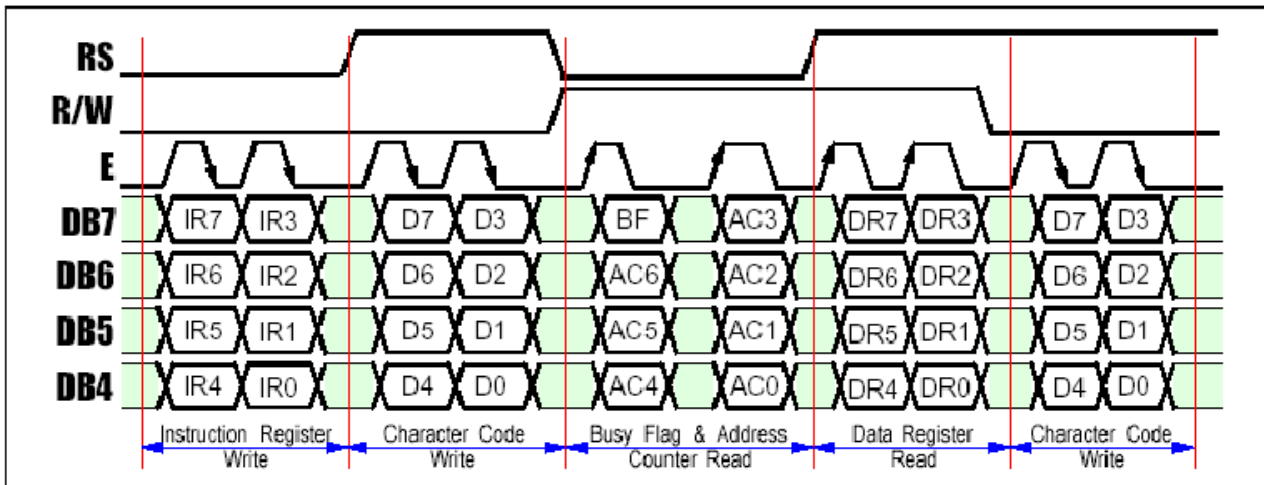

Fig-11 4-Bit Transfer Example (M68)

* For 8-bit interface data, all eight bus lines (DB0 to DB7) are used.

5.3 Transfer selecting

This is used to select the I/F mode: Serial or Parallel Transfer

Now you can operate the jumper "JP3" on the PCB board.

When "JP3" is short, Serial Data Transfer

When "JP3" is open, Parallel Transfer (default)

5.4 Other Jumper Setting

Some jumper are prepared on the PCB board, to set operating mode of the display module.

A soldering iron is required to short jumper.

The jumper "JP1.1" and "JP1.2" are used to reset of module.

M0216MD-162MDBR2-J is n reset inputs from third hole of 14 though holes and M68 CPU bus interface. Reset input signal is active when it is low.

The following table shows the function of JP1.1, JP1.2, JP2.

Table-12 jumper setting

JP2	JP1.1	JP1.2	FUNCTION	
Open	Open	Open	M68 type	MPU type Selection
Short	Open	Open	I80 type	
	Open	Open	Pin #3: No connection	External Reset Section
	×	Short	Pin #3: /Reset signal input (Low Active)	

× : Don't care

6. INSTRUCTIONS

6.1 Outline

Only the instruction register (IR) and the data register (DR) of the VFD controller can be controlled by the user's MPU. Before starting the internal operation of the controller, control information is temporarily stored into these registers to allow interfacing with various MPUs, which operate at different speeds, or various peripheral control devices. The internal operation of the controller is determined by signals sent from the MPU. These signals, which include register selection signal (RS), read/write signal (R/W), and the data bus (DB0 to DB7), make up the controller instructions (See Table_13). There are four categories of instructions that:

- Designate controller functions, such as display format, data length, etc.
- Set internal RAM addresses
- Perform data transfer with internal RAM
- Perform miscellaneous functions

Normally, instructions that perform data transfer with internal RAM are used the most. However, auto-incrementation by 1 (or auto-decrementation by 1) of internal RAM addresses after each data write can lighten the program load of the MPU. Since the display shift instruction can perform concurrently with display data write, the user can minimize system development time with maximum programming efficiency.

When an instruction is being executed for internal operation, no instruction other than the busy flag / address read instruction can be executed. Because the busy flag is set to 1 while an instruction is being executed, check it to make sure it is 0 before sending another instruction from the MPU.

Note : Be sure the controller is not in the busy state (BF = 0) before sending an instruction from the MPU to the module. If an instruction is sent without checking the busy flag, the time between the first instruction and next instruction will take much longer than the instruction time itself. Refer to Table_13 for the list of each instruction execution time.

Instruction	CODE										Description	
	RS	R/W	DB7	DB6	DB5	DB4	DB3	DB2	DB1	DB0		
Display Clear	0	0	0	0	0	0	0	0	0	1	Clears all display and sets DD-RAM address 0 in address counter.	
Cursor Home	0	0	0	0	0	0	0	0	1	**	Sets DDRAM address 0 in ACC. Also returns the display being shifted to the original position. DD-RAM contents remain unchanged.	
Entry Mode Set	0	0	0	0	0	0	0	1	ID	S	Sets the cursor direction and specifies display shift. These operations are performed during writing/reading data.	
Display ON/OFF Control	0	0	0	0	0	0	1	D	C	B	Sets all display ON/OFF(D), cursor ON/OFF(C), cursor blink of character position(B)	
Cursor or Display Shift	0	0	0	0	0	1	S/C	RL	**	**	Shifts display or cursor, keeping DD-RAM contents.	
Function Set	0	0	0	0	1	IF	N	**	BR1	BR0	Sets data length(IF), number of display lines(N), Set brightness level (BR1, BR0)	
CGRAM Address Setting	0	0	0	1	ACG							Sets the CG-RAM address.
DDRAM Address Setting	0	0	1	ADD							Sets the DD-RAM address.	
Busy Flag & Address Reading	0	1	BF	ACC							Read busy flag(BF) and address counter (ACC).	
Data Writing to CG or DDRAM	1	0	Data writing							Writes data into CG-RAM or DDRAM.		
Data Reading from CG or DDRAM	1	1	Data reading							Reads data from CG-RAM or DDRAM.		

Instruction	CODE										Description	
	RS	R/W	DB7	DB6	DB5	DB4	DB3	DB2	DB1	DB0		
Display Clear	0	0	0	0	0	0	0	0	0	1	Clears all display and sets DD-RAM address 0 in address counter.	
Cursor Home	0	0	0	0	0	0	0	0	1	**	Sets DDRAM address 0 in ACC. Also returns the display being shifted to the original position. DD-RAM contents remain unchanged.	
Entry Mode Set	0	0	0	0	0	0	0	1	ID	S	Sets the cursor direction and specifies display shift. These operations are performed during writing/reading data.	
Display ON/OFF Control	0	0	0	0	0	0	1	D	C	B	Sets all display ON/OFF(D), cursor ON/OFF(C), cursor blink of character position(B)	
Cursor or Display Shift	0	0	0	0	0	1	S/C	RL	**	**	Shifts display or cursor, keeping DD-RAM contents.	
Function Set	0	0	0	0	1	IF	N	**	BR1	BR0	Sets data length(IF), number of display lines(N), Set brightness level (BR1, BR0)	
CGRAM Address Setting	0	0	0	1	ACG							Sets the CG-RAM address.
DDRAM Address Setting	0	0	1	ADD							Sets the DD-RAM address.	
Busy Flag & Address Reading	0	1	BF	ACC							Read busy flag(BF) and address counter (ACC).	
Data Writing to CG or DDRAM	1	0	Data writing							Writes data into CG-RAM or DDRAM.		
Data Reading from CG or DDRAM	1	1	Data reading							Reads data from CG-RAM or DDRAM.		

6.2 Instruction Descriptions

6.2.1 Display Clear

DB7	DB6	DB5	DB4	DB3	DB2	DB1	DB0	
0	0	0	0	0	0	0	1	01H

RS = 0, R/W = 0

This instruction

- (1) Fills all locations in the display data RAM (DD-RAM) with 20H (Blank-character).
- (2) Clears the contents of the address counter (ACC) to 00H.
- (3) Sets the display for zero character shift (returns original position).
- (4) Sets the address counter (ACC) to point to the DD-RAM.
- (5) If the cursor is displayed, moves the cursor to the left most character in the top line (upper line).
- (6) Sets the address counter (ACC) to increment on the each access of DD-RAM or CG-RAM.

6.2.2 Cursor Home

DB7	DB6	DB5	DB4	DB3	DB2	DB1	DB0	
0	0	0	0	0	0	1	**	02H to 03H

RS = 0, R/W = 0

** : Don't care

This instruction

- (1) Clears the contents of the address counter (ACC) to 00H.
- (2) Sets the address counter (ACC) to point to the DD-RAM.
- (3) Sets the display for zero character shift (returns original position).
- (4) If the cursor is displayed, moves the left most character in the top line (upper line).

6.2.3 Entry Mode Set

DB7	DB6	DB5	DB4	DB3	DB2	DB1	DB0	
0	0	0	0	0	1	I/D	S	04H to 07H

RS = 0, R/W = 0

The I/D bit selects the way in which the contents of the address counter (ACC) are modified after every access to DD-RAM or CG-RAM.

- I/D = 1 : The address counter (ACC) is incremented.
- I/D = 0 : The address counter (ACC) is decremented.

The S bit enables display shift, instead of cursor shift, after each write or read to the DD-RAM.

- S = 1 : Display shift enabled.
- S = 0 : Cursor shift enabled.

The direction in which the display is shifted is opposite in sense to that of the cursor.

For example, if S=0 and I/D=1, the cursor would shift one character to the right after a MPU writes to DD-RAM. However if S=1 and I/D=1, the display would shift one character to the left and the cursor would maintain its position on the panel.

The cursor will already be shifted in the direction selected by I/D during reads of the DD-RAM, irrespective of the value of S. Similarly reading and writing the CG-RAM always shift the cursor. Also both lines are shifted simultaneously.

Table-14 Cursor move and Display shift by the "Entry Mode Set"

I/D	S	After writing DD-RAM data	After reading DD-RAM data
0	0	The cursor moves one character to the left.	The cursor moves one character to the left.
1	0	The cursor moves one character to the right.	The cursor moves one character to the right.
0	1	The display shifts one character to the right without cursor's move.	The cursor moves one character to the left.
1	1	The display shifts one character to the left without cursor's move.	The cursor moves one character to the right.

6.2.4 Display ON/OFF

DB7	DB6	DB5	DB4	DB3	DB2	DB1	DB0	
0	0	0	0	1	D	C	B	08H to 0FH

RS = 0, R/W = 0

This instruction controls various features of the display.

D = 1 : Display on, D = 0 : Display off.

C = 1 : Cursor on, C = 0 : Cursor off.

B = 1 : Blinking on, B = 0 : Blinking off

(Blinking is achieved by alternating between a normal and all on display of a character. The cursor blinks with a frequency of about 1.0 Hz and DUTY 50%.)

6.2.5 Cursor/Display Shift

DB7	DB6	DB5	DB4	DB3	DB2	DB1	DB0	
0	0	0	1	S/C	R/L	**	**	10H to 1FH

RS = 0, R/W = 0 ** : Don't care

This instruction shifts the display and/or moves the cursor, one character to the left or right, without reading or writing DD-RAM.

The S/C bit selects movement of the cursor or movement of both the cursor and the display.

S/C = 1 : Shift both cursor and display

S/C = 0 : Shift cursor only

The R/L bit selects left ward or right ward movement of the display and/or cursor.

R/L = 1 : Shift one character right

R/L = 0 : Shift one character left

Table-15 Cursor/Display shift

S/C	R/L	Cursor shift	Display shift
0	0	Move one character to the left	No shift
0	1	Move one character to the right	No shift
1	0	Shift one character to the left with display	Shift one character to the left
1	1	Shift one character to the right with display	Shift one character to the right

6.2.6 Function Set

DB7	DB6	DB5	DB4	DB3	DB2	DB1	DB0	
0	0	1	IF	N	..	BR1	BR0	20H to 3FH

RS = 0, R/W = 0

.. : Don't care

This instruction sets width of data bus line.(when to use parallel interface. IM=1), the number of display line and brightness control.

This instruction initializes the system, and must be the first instruction executed after power-on.

The IF bit selects between an 8-bit or 4-bit bus width interface.

IF = 1 : 8-bit CPU interface using DB7 to DB0

IF = 0 : 4-bit CPU interface using DB7 to DB4

The N bit selects between 1-line or 2-line display.

N = 1 : Select 2 line display (Using anode output A1 to A80)

N = 0 : Select 1 line display (Using anode output A1 to A40. A41 to A80 fixed Low level.)

BR1, BR0 flag is control to brightness of VFD to modulate pulse width of Anode output as follows.

BR1	BR0	Brightness
0	0	100 %
0	1	75 %
1	0	50 %
1	1	25 %

6.2.7 Set CG-RAM Address

DB7	DB6	DB5	DB4	DB3	DB2	DB1	DB0		
0	1	ACG							40H to 7FH

RS = 0, R/W = 0

This instruction

- (1) Load a new 6-bit address into the address counter (ACC).
- (2) Sets the address counter (ACC) to address CG-RAM.

Once "Set CG-RAM Address" has been executed, the contents of the address counter (ACC) will be automatically modified after every access of CG-RAM, as determined by the "Entry Mode Set" instruction. The active width of the address counter (ACC), when it is addressing CG-RAM, is 6 bits, so the counter will wrap around to 00H from 3FH if more than 64 bytes of data are written to CG-RAM.

6.2.8 Set DD-RAM Address

DB7	DB6	DB5	DB4	DB3	DB2	DB1	DB0		
1	ADD								80H to A7H (1-Line) C0H to E7H (2-Line)

RS = 0, R/W = 0

This instruction

- (1) Loads a new 7-bit address into the address counter (ACC).
- (2) Sets the address counter (ACC) to point to the DD-RAM.

Once the "Set DD-RAM Address" instruction has been executed, the contents of the address counter (ACC) will be automatically modified after each access of DD-RAM, as selected by the "Entry Mode Set" instruction.

Table-16 Valid DD-RAM address Ranges

	Number of Character	Address Range
1st line	40	00H to 27H
2nd line	40	40H to 67H

6.2.9 Read Busy Flag and Address

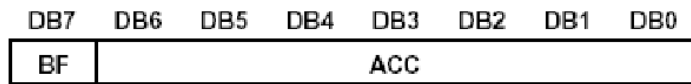

RS = 0, R/W = 1

Read busy flag and address reads the busy flag (BF) indicating that the system is now internally operating on a previously received instruction. If BF is 1, the internal operation is in progress.

BF = 1 : busy state

BF = 0 : ready for next instruction, command receivable.

The next instruction will not be accepted until BF is reset to 0. Check the BF status before the next write operation. At the same time, the value of the address counter (ACC) in binary AAAAAAA is read out. This address counter (ACC) is used by both CG-RAM and DD-RAM addresses, and its value is determined by the previous instruction. The address contents are the same as for instructions set CG-RAM address and set DD-RAM address.

6.2.10 Write Data to CG or DD-RAM

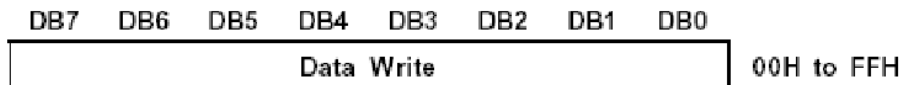

RS = 1, R/W = 0

This instruction writes 8-bit binary data (DB7 to DB0) into CG-RAM or DD-RAM.

To write into CG-RAM or DD-RAM is determined by the previous specification of the CG-RAM or DD-RAM address setting. After a write, the address is automatically incremented or decremented by 1 according to the entry mode. The entry mode also determines the display shift.

When data is written to the CG-RAM, the DB7, DB6 and DB5 bits are not displayed as characters.

6.2.11 Read Data from CG or DD-RAM

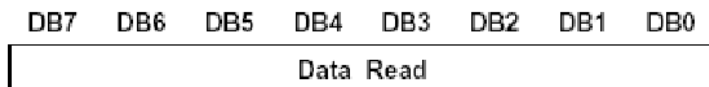

RS = 1, R/W = 1

This instruction reads 8-bit binary data (DB7 to DB0) from CG-RAM or DD-RAM.

The previous designation determines whether CG-RAM or DD-RAM is to be read.

Before entering this read instruction, either CG-RAM or DD-RAM address set instruction must be executed. If not executed, the first read data will be invalid. When serially executing read instructions, the next address data is normally read from the second read. The address set instructions need not be executed just before this read instruction when shifting the cursor by the cursor shift instruction (when reading out DD-RAM).

The operation of the cursor shift instruction is the same as the set DD-RAM address instruction.

After a read, the entry mode automatically increases or decreases the address by 1.

Note : The address counter (ACC) is automatically incremented or decremented by 1 after the write instructions to CG-RAM or DD-RAM are executed. The RAM data selected by the ACC cannot be read out at this time even if read instructions are executed. Therefore, to correctly read data, execute either the address set instruction or cursor shift instruction (only with DD-RAM), then just before reading the desired data, execute the read instruction from the second time the read instruction is sent.

7. OPERATING RECOMMENDATIONS

- 7.1 Avoid applying excessive shock or vibration beyond the specification for the VFD module.
- 7.2 Since VFDs are made of glass material, careful handling is required.
i.e. Direct impact with hard material to the glass surface (especially exhaust tip) may crack the glass.
- 7.3 When mounting the VFD module to your system, leave a slight gap between the VFD glass and your front panel.
The module should be mounted without stress to avoid flexing of the PCB.
- 7.4 Avoid plugging or unplugging the interface connection with the power on, otherwise it may cause the severe damage to input circuitry.
- 7.5 Slow starting power supply may cause non-operation because one chip microm won't be reset.
- 7.6 Exceeding any of maximum ratings may cause the permanent damage.
- 7.7 Since the VFD modules contain high voltage source, careful handling is required during powered on.
- 7.8 When the power is turned off, the capacitor does not discharge immediately.
The high voltage applied to the VFD must not contact to the ICs. And the short-circuit of mounted components on PCB within 30 seconds after power-off may cause damage to those.
- 7.9 The power supply must be capable of providing at least 3 times the rated current, because the surge current can be more than 3 times the specified current consumption when the power is turned on.
- 7.10 Avoid using the module where excessive noise interference is expected. Noise may affect the interface signal and causes improper operation. And it is important to keep the length of the interface cable less than 50cm.
- 7.11 Since all VFD modules contain C-MOS ICs, anti-static handling procedures are always required.

NOTE:

Information in this document is provided solely in connection with Newhaven Display products. Newhaven Display reserves the right to make changes, corrections, modifications or improvements to this document and the products described herein at any time without notice.

All Newhaven Display products are sold pursuant to Newhaven Display terms and conditions of sale. Purchasers are solely responsible for the choice, selection or use of the Newhaven Display products and services described herein and Newhaven Display assumes no liability whatsoever relating to the choice, selection or use of the Newhaven Display products and services described herein. No license, express or implied by estoppel or otherwise to any intellectual property rights is granted under this document.

Компания «Life Electronics» занимается поставками электронных компонентов импортного и отечественного производства от производителей и со складов крупных дистрибьюторов Европы, Америки и Азии.

С конца 2013 года компания активно расширяет линейку поставок компонентов по направлению коаксиальный кабель, кварцевые генераторы и конденсаторы (керамические, пленочные, электролитические), за счёт заключения дистрибьюторских договоров

Мы предлагаем:

- Конкурентоспособные цены и скидки постоянным клиентам.
- Специальные условия для постоянных клиентов.
- Подбор аналогов.
- Поставку компонентов в любых объемах, удовлетворяющих вашим потребностям.
- Приемлемые сроки поставки, возможна ускоренная поставка.
- Доставку товара в любую точку России и стран СНГ.
- Комплексную поставку.
- Работу по проектам и поставку образцов.
- Формирование склада под заказчика.
- Сертификаты соответствия на поставляемую продукцию (по желанию клиента).
- Тестирование поставляемой продукции.
- Поставку компонентов, требующих военную и космическую приемку.
- Входной контроль качества.
- Наличие сертификата ISO.

В составе нашей компании организован Конструкторский отдел, призванный помогать разработчикам, и инженерам.

Конструкторский отдел помогает осуществить:

- Регистрацию проекта у производителя компонентов.
- Техническую поддержку проекта.
- Защиту от снятия компонента с производства.
- Оценку стоимости проекта по компонентам.
- Изготовление тестовой платы монтаж и пусконаладочные работы.



Тел: +7 (812) 336 43 04 (многоканальный)

Email: org@lifeelectronics.ru