

LOC	DIST	REV	DESCRIPTION	DATE	BY	APPV
C	REV PER ECO-07-017102			20SEP07	PY	BW

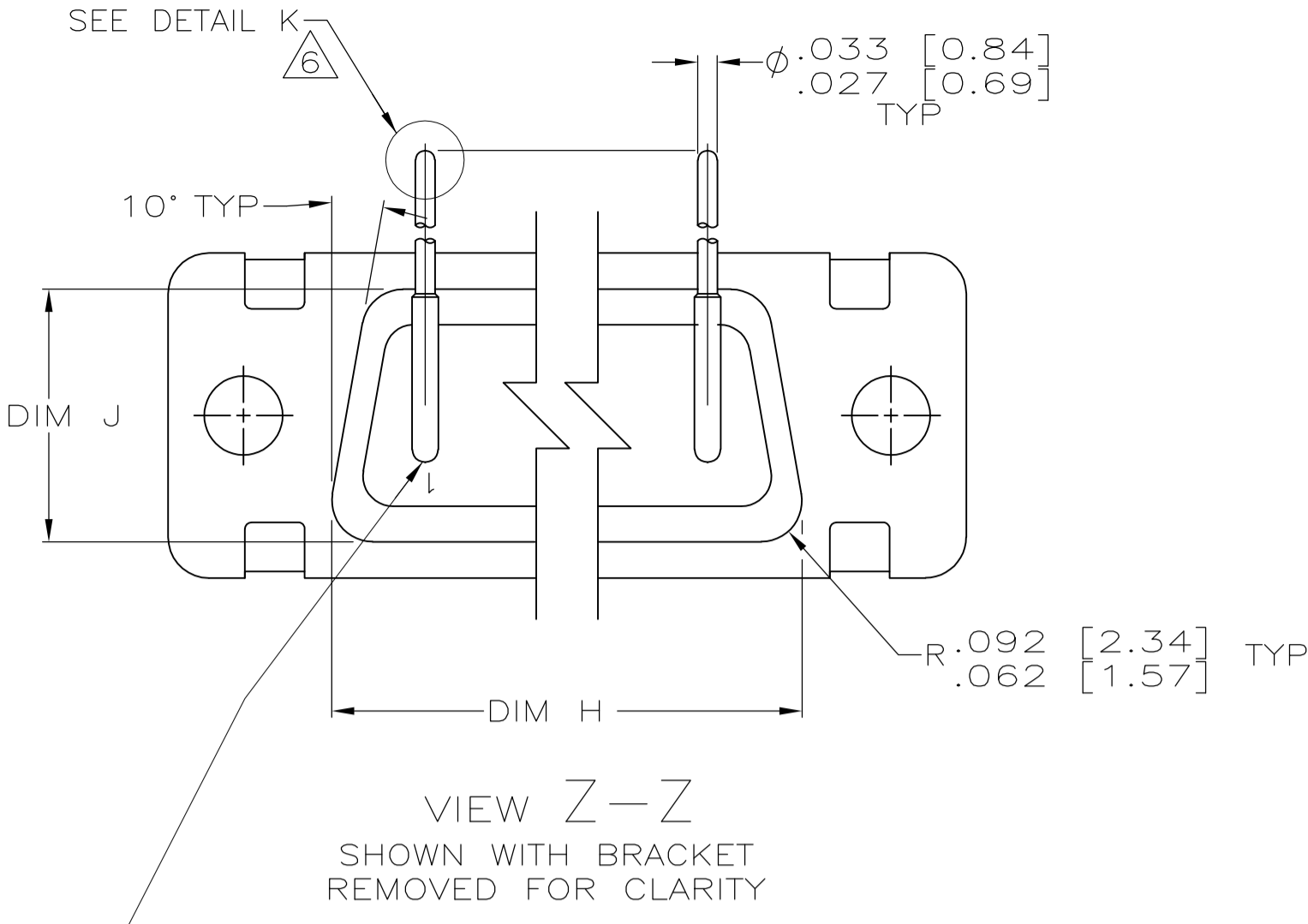

CONTACT (QTY = NO. OF POSN)  
 MATL: BRASS PER ASTM-B-16, OR BERYLLIUM COPPER PER ASTM-B-194  
 FINISH: GOLD PER MIL-G-45204, TYPE II, GRADE C, CLASS 1 IN CONTACT MATING AREA, .000010 [0.0003] MIN THK GOLD PER MIL-G-45204 OVER .000050 [0.0013] MIN THK NICKEL PER QQ-N-290 ON CONTACT BODY

- 1. SEE SHEET 2 FOR RECOMMENDED P.C. BOARD LAYOUT. TRUE POSITION TOLERANCE FOR P.C. BOARD LAYOUT IS .010 [0.25] AT MAX MATERIAL CONDITION. SUGGESTED BOARD THICKNESS IS .062 [1.57]
  - 2. THE CONNECTORS DESCRIBED IN THIS DOCUMENT MEET THE REQUIREMENTS OF MIL-C-24308 AND MATE WITH ANY RECEPTACLE CONNECTOR WITH SAME INSERT ARRANGEMENT.
  - 3. MARKED WITH .047 [1.19]-.062 [1.57] HIGH CHARACTERS. FAR SIDE REFERS TO THE WIDE SIDE OF THE KEYSTONE. NEAR SIDE REFERS TO THE NARROW SIDE OF THE KEYSTONE. IF THE REAR SHELL IS TOO SMALL FOR THE ENTIRE MILITARY PART NUMBER, MARKING SHALL BE LOCATED AS FOLLOWS:
    - A. "M24308" ON FRONT SHELL, FAR SIDE.
    - B. SLASH SHEET AND DASH NUMBER ON REAR SHELL, FAR SIDE.
    - C. "AMP" AND DATE CODE ON FRONT SHELL, NEAR SIDE.
    - D. AMP PART NUMBER ON REAR SHELL, NEAR SIDE.
- IF THE FRONT SHELL IS TOO SMALL FOR "AMP", AMP PART NUMBER AND DATE CODE, MARKING SHALL BE SPLIT AS FOLLOWS:
- A. AMP PART NUMBER ON REAR SHELL, NEAR SIDE.
  - B. "AMP" AND DATE CODE ON FRONT SHELL, NEAR SIDE.
  - C. MILITARY PART NUMBER ON REAR SHELL, FAR SIDE.

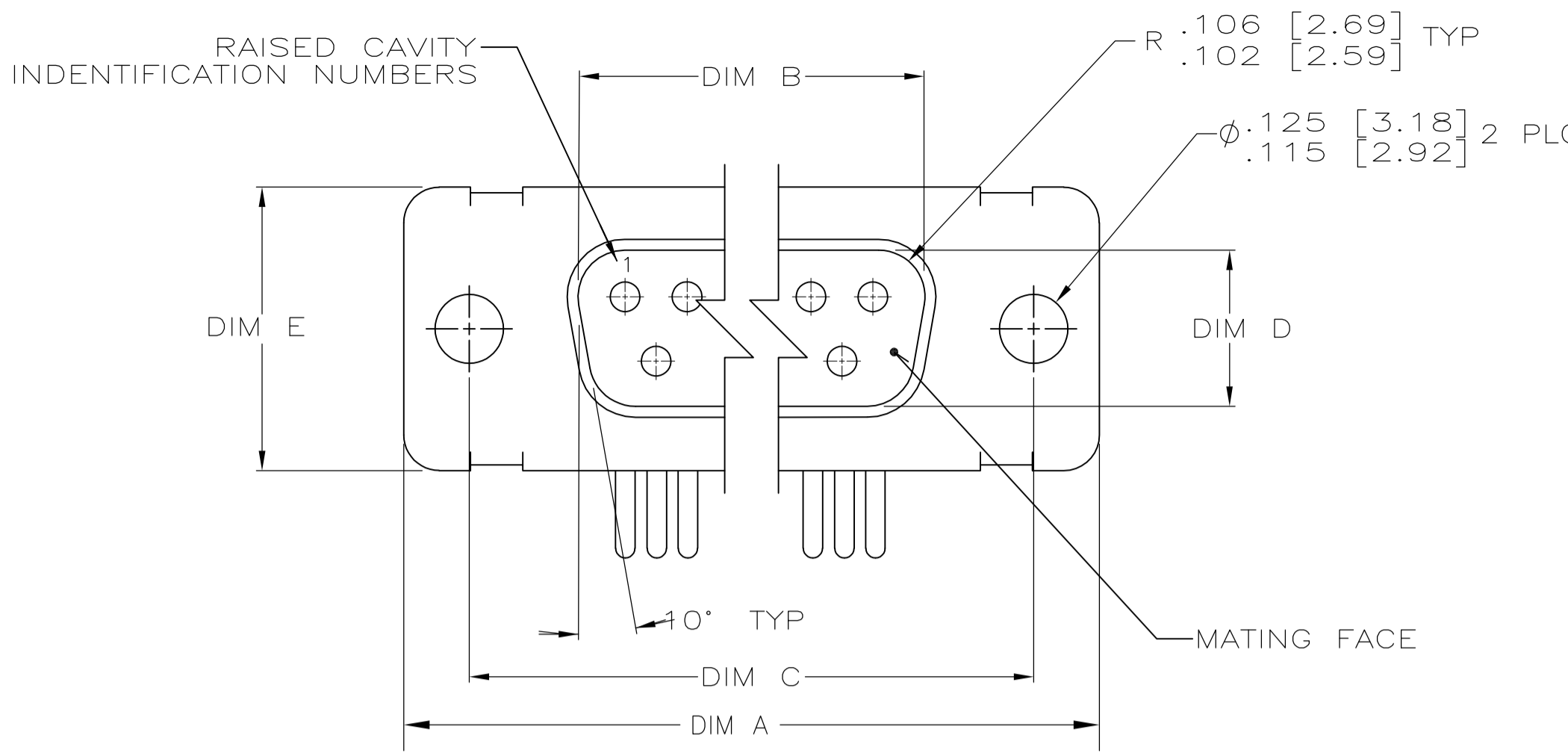
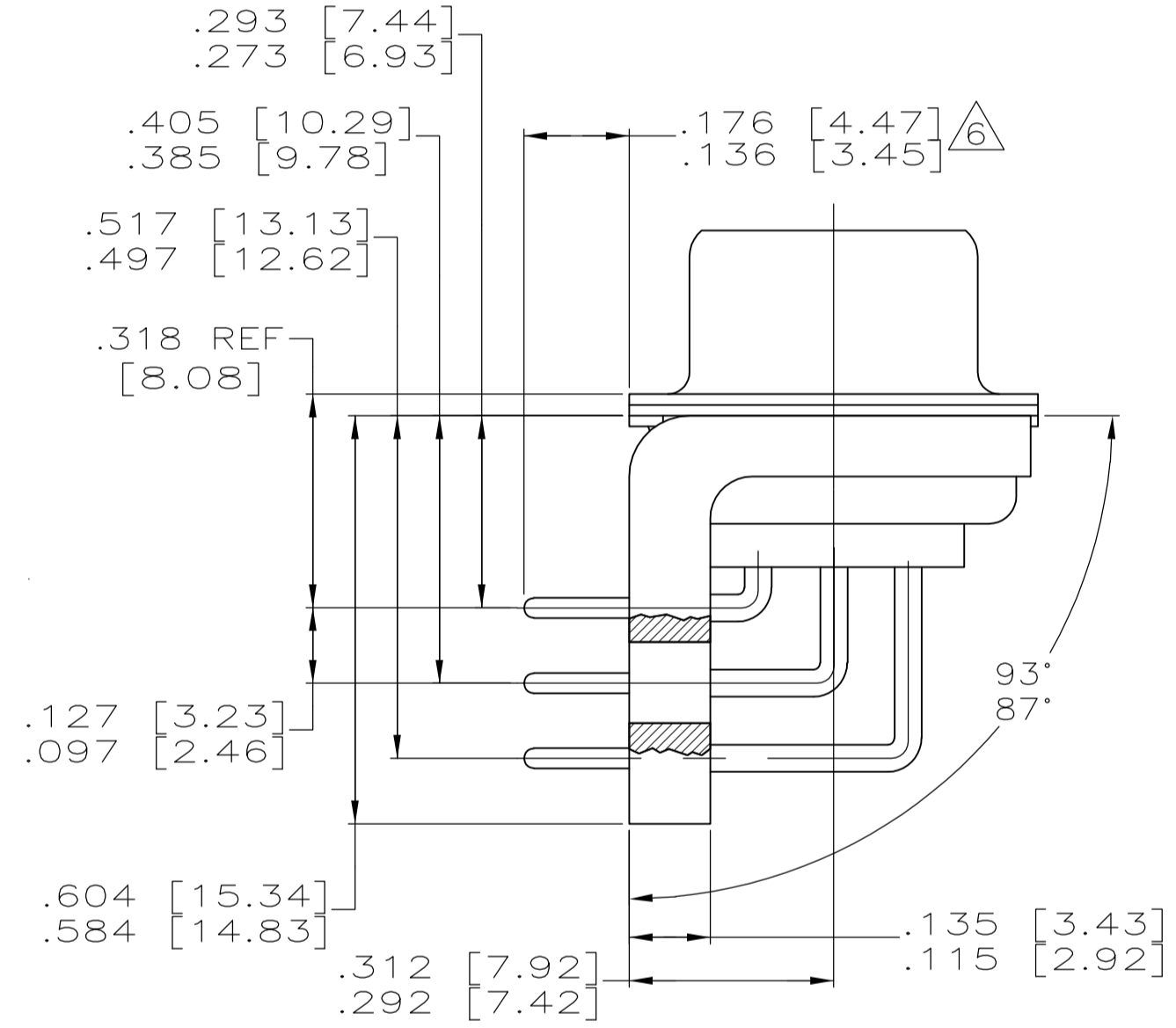
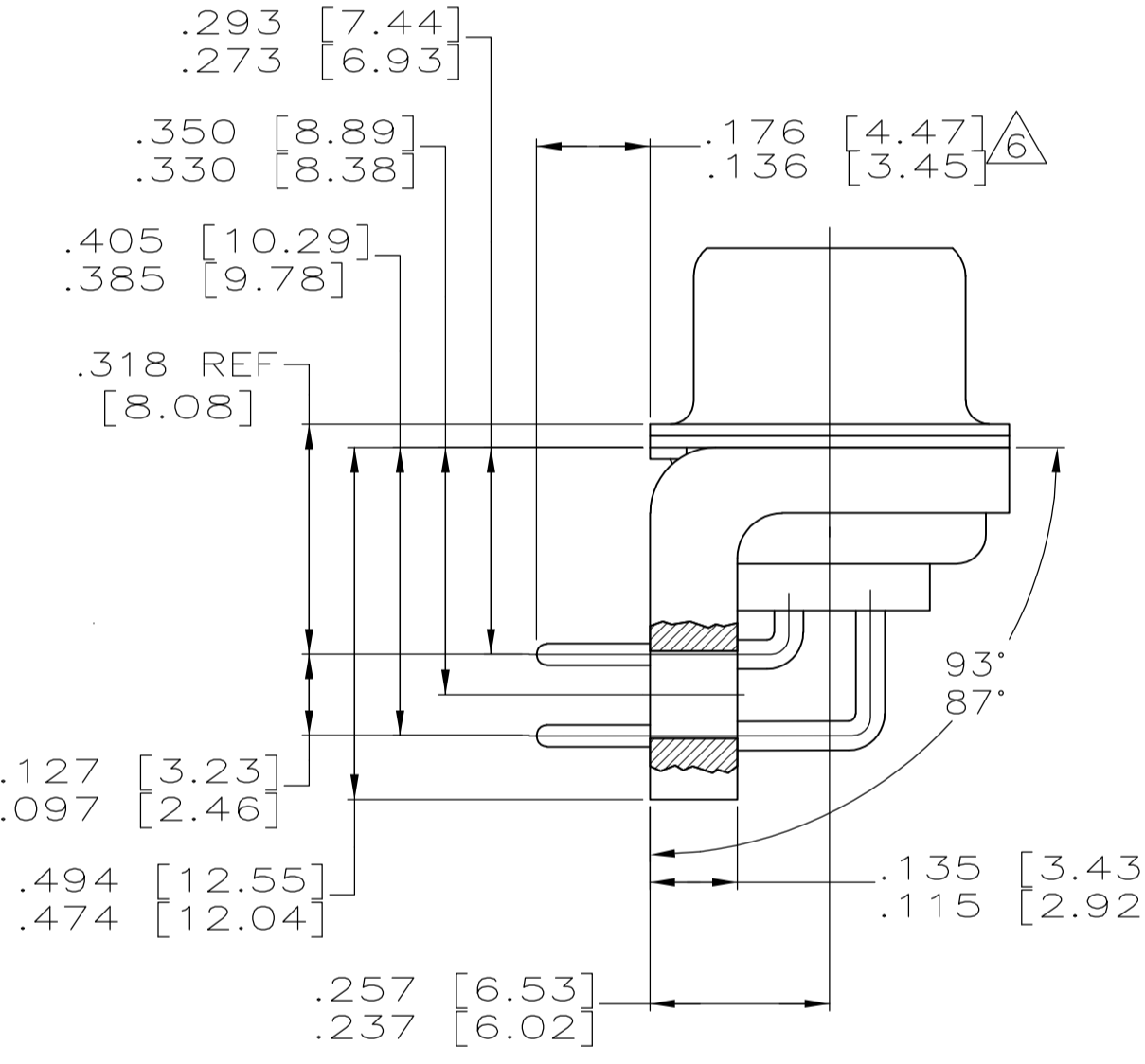
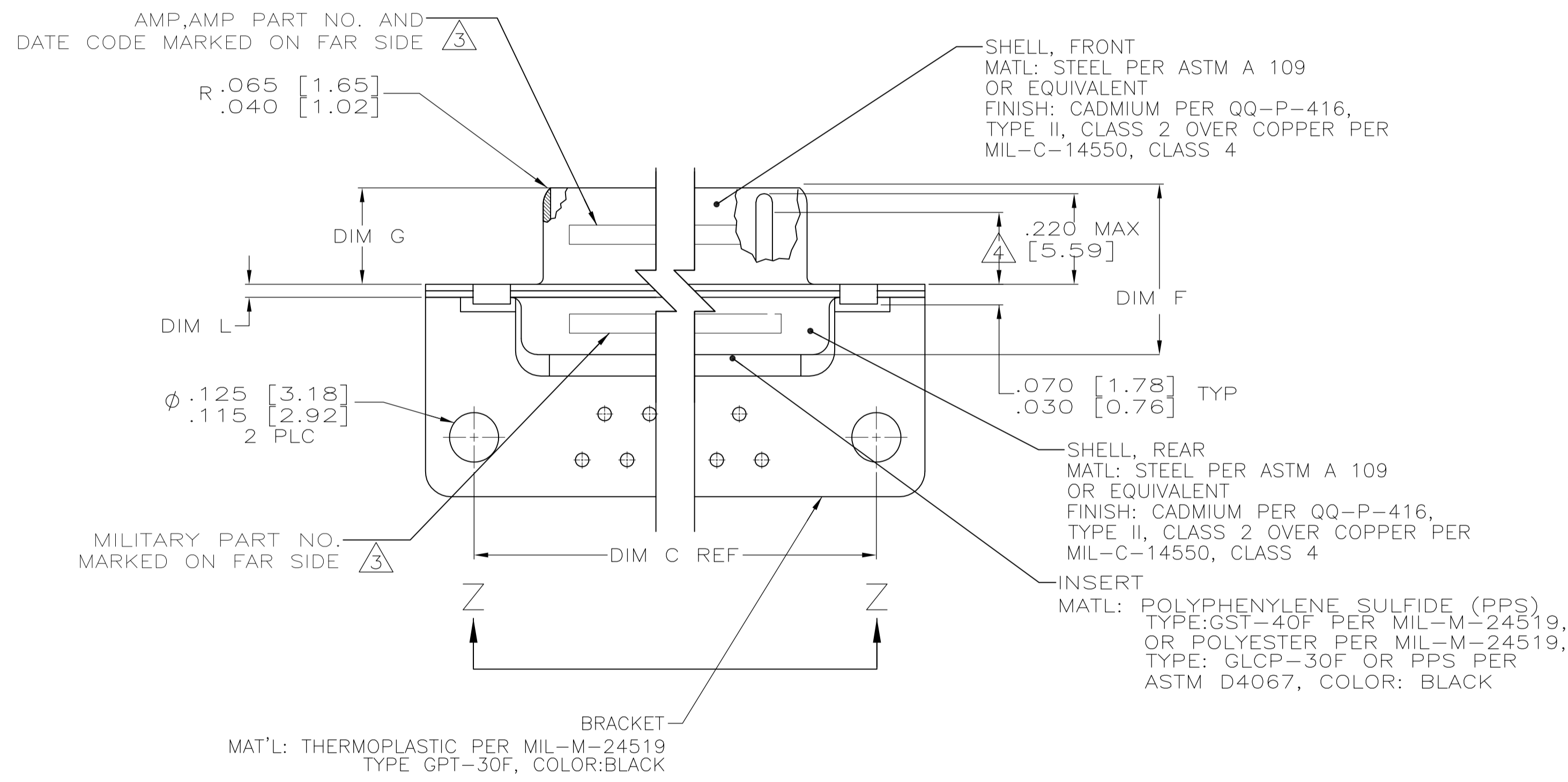

.049 [1.24]	.544 [13.82]	2.188 [55.58]	.236 [5.99]	.436 [11.07]	.620 [15.75]	.446 [11.33]	2.411 [61.24]	2.084 [52.55]	2.650 [67.31]	MS18277-1	50	5	M24308/24-35F	1218441-5	1-1218441-0
.029 [0.74]	.524 [13.31]	2.168 [55.07]	.224 [5.69]	.416 [10.57]	.590 [14.99]	.436 [11.07]	2.401 [60.99]	2.074 [52.30]	2.620 [66.55]	MS18276-1	37	4	M24308/24-34F	1218441-4	1218441-9
.049 [1.24]	.432 [10.97]	2.282 [57.96]	.236 [5.99]	.436 [11.07]	.509 [12.93]	.334 [8.48]	2.505 [63.63]	2.187 [54.97]	2.744 [69.70]	MS18275-1	25	3	M24308/24-33F	1218441-3	1218441-8
.029 [0.74]	.412 [10.46]	2.262 [57.45]	.224 [5.69]	.416 [10.57]	.479 [12.17]	.324 [8.23]	2.495 [63.37]	2.177 [54.71]	2.714 [68.94]	MS18274-1	15	2	M24308/24-32F	1218441-2	1218441-7
.049 [1.24]	.432 [10.97]	1.635 [41.53]	.236 [5.99]	.436 [11.07]	.509 [12.93]	.334 [8.48]	1.857 [47.17]	1.539 [38.51]	2.103 [53.42]	MS18273-1	9	1	M24308/24-31F	1218441-1	1218441-6
.029 [0.74]	.412 [10.46]	1.615 [41.02]	.224 [5.69]	.416 [10.57]	.479 [12.17]	.324 [8.23]	1.847 [46.91]	1.529 [38.25]	2.073 [52.65]	MS18277-1	50	5	M24308/24-35F	1218441-5	1218441-5
.049 [1.24]	.432 [10.97]	2.282 [57.96]	.236 [5.99]	.436 [11.07]	.509 [12.93]	.334 [8.48]	2.505 [63.63]	2.187 [54.97]	2.744 [69.70]	MS18276-1	37	4	M24308/24-34F	1218441-4	1218441-4
.029 [0.74]	.412 [10.46]	2.262 [57.45]	.224 [5.69]	.416 [10.57]	.479 [12.17]	.324 [8.23]	2.495 [63.37]	2.177 [54.71]	2.714 [68.94]	MS18275-1	25	3	M24308/24-33F	1218441-3	1218441-3
.049 [1.24]	.432 [10.97]	1.635 [41.53]	.236 [5.99]	.436 [11.07]	.509 [12.93]	.334 [8.48]	1.857 [47.17]	1.539 [38.51]	2.103 [53.42]	MS18274-1	15	2	M24308/24-32F	1218441-2	1218441-2
.029 [0.74]	.412 [10.46]	1.615 [41.02]	.224 [5.69]	.416 [10.57]	.479 [12.17]	.324 [8.23]	1.847 [46.91]	1.529 [38.25]	2.073 [52.65]	MS18273-1	9	1	M24308/24-31F	1218441-1	1218441-1
.049 [1.24]	.544 [13.82]	2.188 [55.58]	.236 [5.99]	.436 [11.07]	.620 [15.75]	.446 [11.33]	2.411 [61.24]	2.084 [52.55]	2.650 [67.31]	MS18277-1	50	5	M24308/24-35F	1218441-5	1218441-5
.029 [0.74]	.524 [13.31]	2.168 [55.07]	.224 [5.69]	.416 [10.57]	.590 [14.99]	.436 [11.07]	2.401 [60.99]	2.074 [52.30]	2.620 [66.55]	MS18276-1	37	4	M24308/24-34F	1218441-4	1218441-4
.049 [1.24]	.432 [10.97]	2.282 [57.96]	.236 [5.99]	.436 [11.07]	.509 [12.93]	.334 [8.48]	2.505 [63.63]	2.187 [54.97]	2.744 [69.70]	MS18275-1	25	3	M24308/24-33F	1218441-3	1218441-3
.029 [0.74]	.412 [10.46]	2.262 [57.45]	.224 [5.69]	.416 [10.57]	.479 [12.17]	.324 [8.23]	2.495 [63.37]	2.177 [54.71]	2.714 [68.94]	MS18274-1	15	2	M24308/24-32F	1218441-2	1218441-2
.049 [1.24]	.432 [10.97]	1.635 [41.53]	.236 [5.99]	.436 [11.07]	.509 [12.93]	.334 [8.48]	1.857 [47.17]	1.539 [38.51]	2.103 [53.42]	MS18273-1	9	1	M24308/24-31F	1218441-1	1218441-1
.029 [0.74]	.412 [10.46]	1.615 [41.02]	.224 [5.69]	.416 [10.57]	.479 [12.17]	.324 [8.23]	1.847 [46.91]	1.529 [38.25]	2.073 [52.65]	MS18277-1	50	5	M24308/24-35F	1218441-5	1218441-5
.049 [1.24]	.432 [10.97]	2.282 [57.96]	.236 [5.99]	.436 [11.07]	.509 [12.93]	.334 [8.48]	2.505 [63.63]	2.187 [54.97]	2.744 [69.70]	MS18276-1	37	4	M24308/24-34F	1218441-4	1218441-4
.029 [0.74]	.412 [10.46]	2.262 [57.45]	.224 [5.69]	.416 [10.57]	.479 [12.17]	.324 [8.23]	2.495 [63.37]	2.177 [54.71]	2.714 [68.94]	MS18275-1	25	3	M24308/24-33F	1218441-3	1218441-3
.049 [1.24]	.432 [10.97]	1.635 [41.53]	.236 [5.99]	.436 [11.07]	.509 [12.93]	.334 [8.48]	1.857 [47.17]	1.539 [38.51]	2.103 [53.42]	MS18274-1	15	2	M24308/24-32F	1218441-2	1218441-2
.029 [0.74]	.412 [10.46]	1.615 [41.02]	.224 [5.69]	.416 [10.57]	.479 [12.17]	.324 [8.23]	1.847 [46.91]	1.529 [38.25]	2.073 [52.65]	MS18273-1	9	1	M24308/24-31F	1218441-1	1218441-1

DIM L	DIM J	DIM H	DIM G	DIM F	DIM E	DIM D	DIM C	DIM B	DIM A	INSERT ARRANGEMENT	NO OF POS	SHELL SIZE	MILITARY P/N ON CONNECTOR	AMP P/N MARKED ON CONNECTOR	AMP PART NO.

DETAIL K  
 SCALE 8:1  
 FOR 1218441-6 THRU -10 ONLY

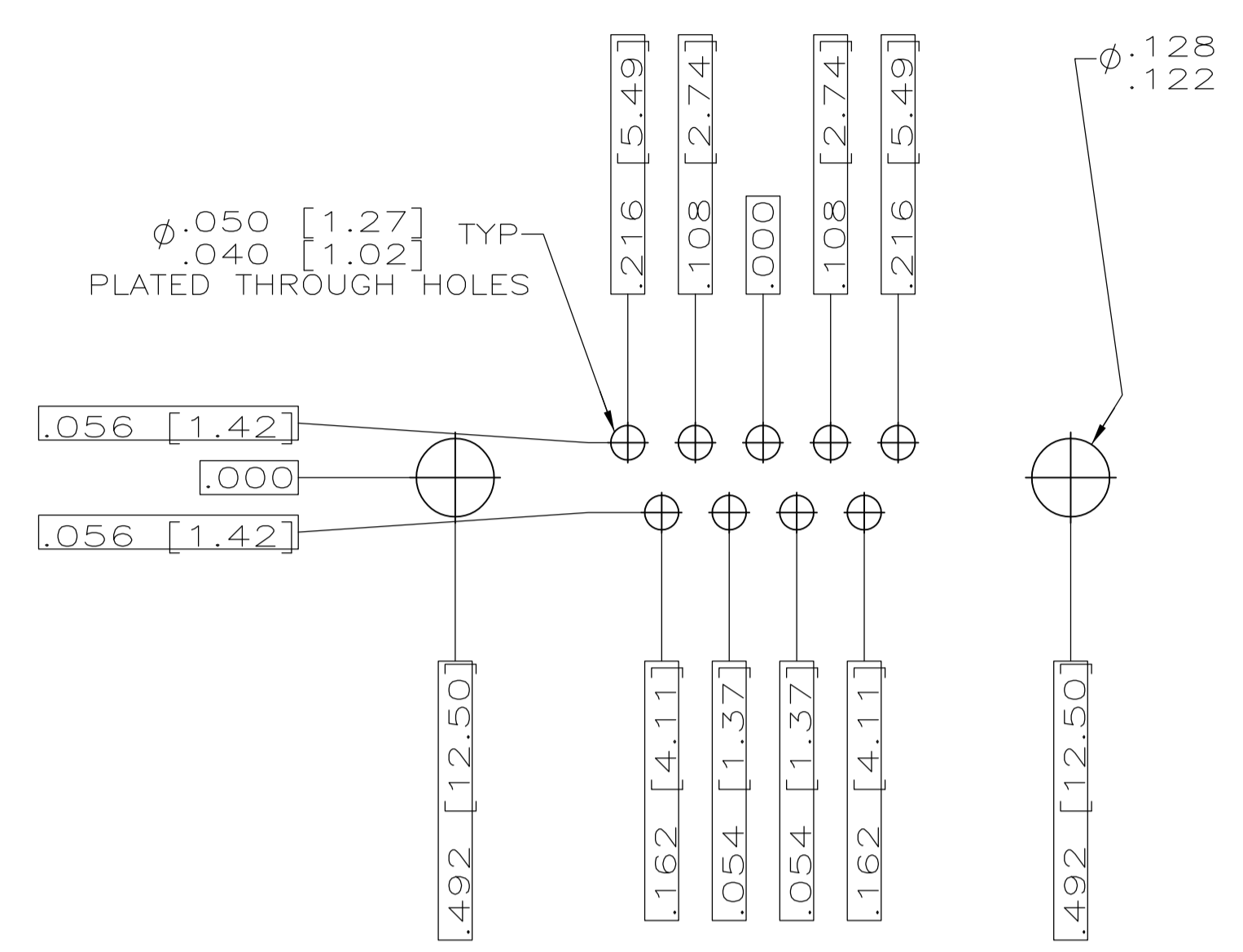

RECOMMENDED P.C. BOARD LAYOUT  
SHELL SIZE 1 (9 POSITION) ⚠

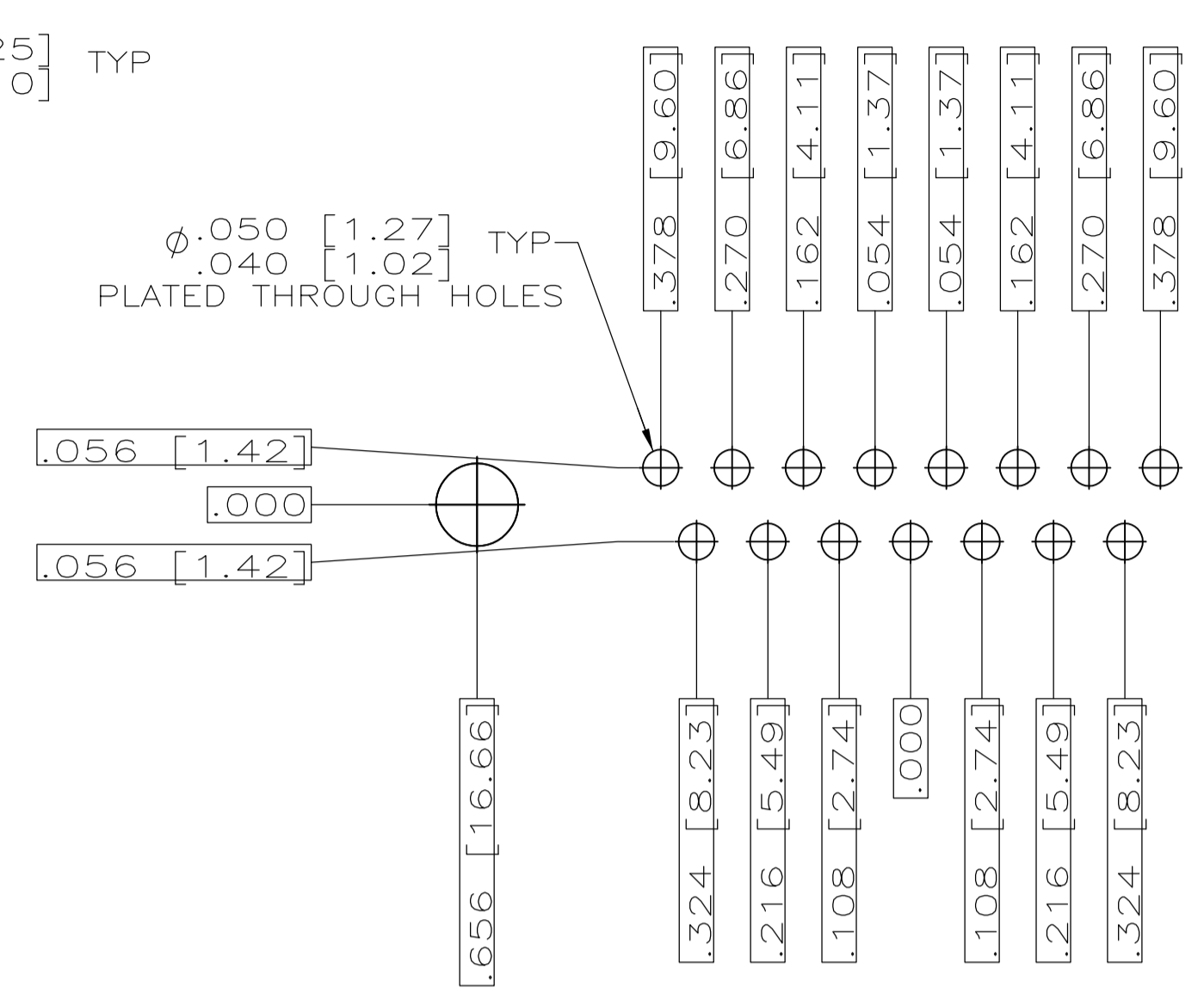

RECOMMENDED P.C. BOARD LAYOUT  
SHELL SIZE 2 (15 POSITION) ⚠

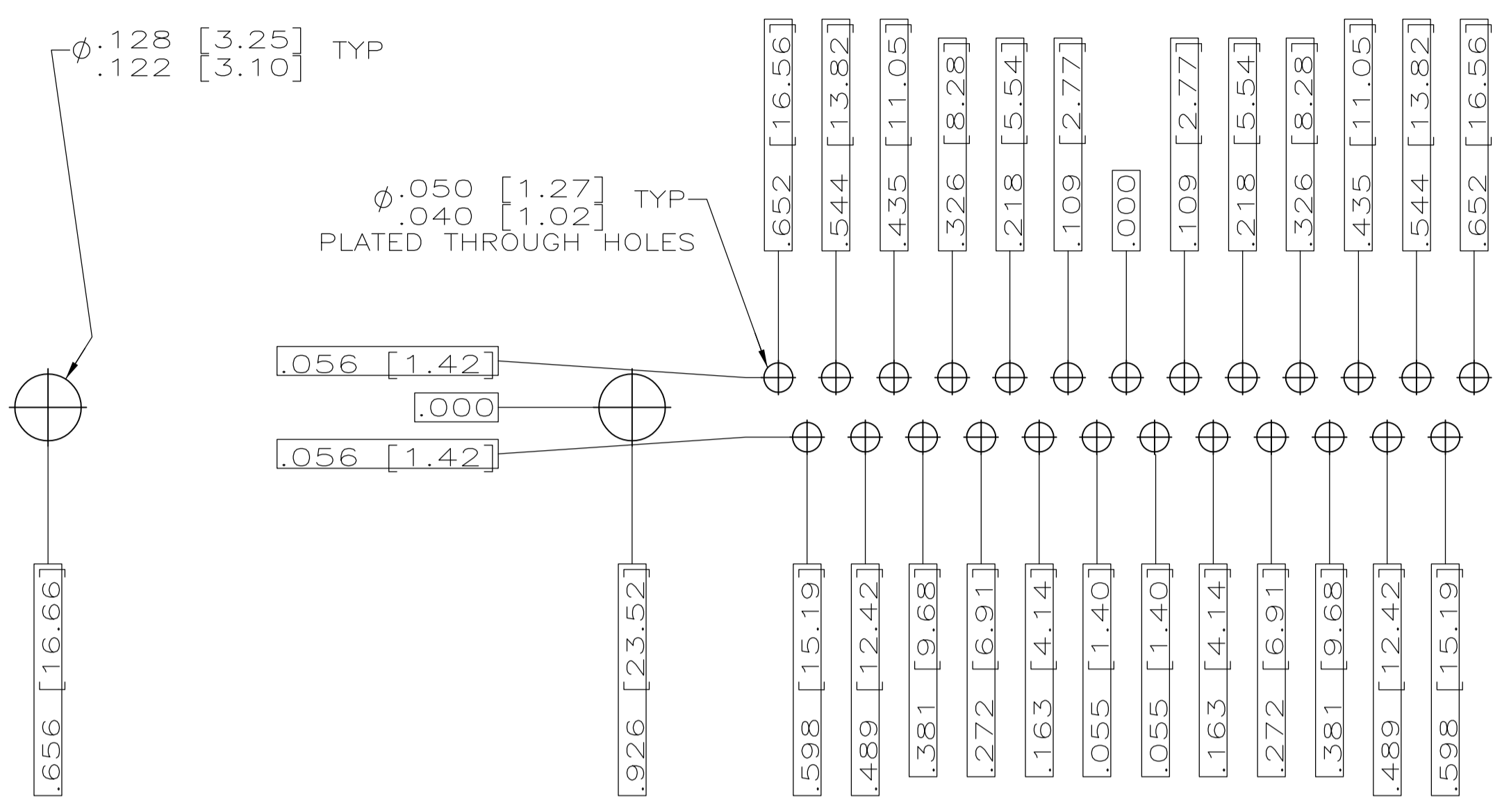

RECOMMENDED P.C. BOARD LAYOUT  
SHELL SIZE 3 (25 POSITION) ⚠

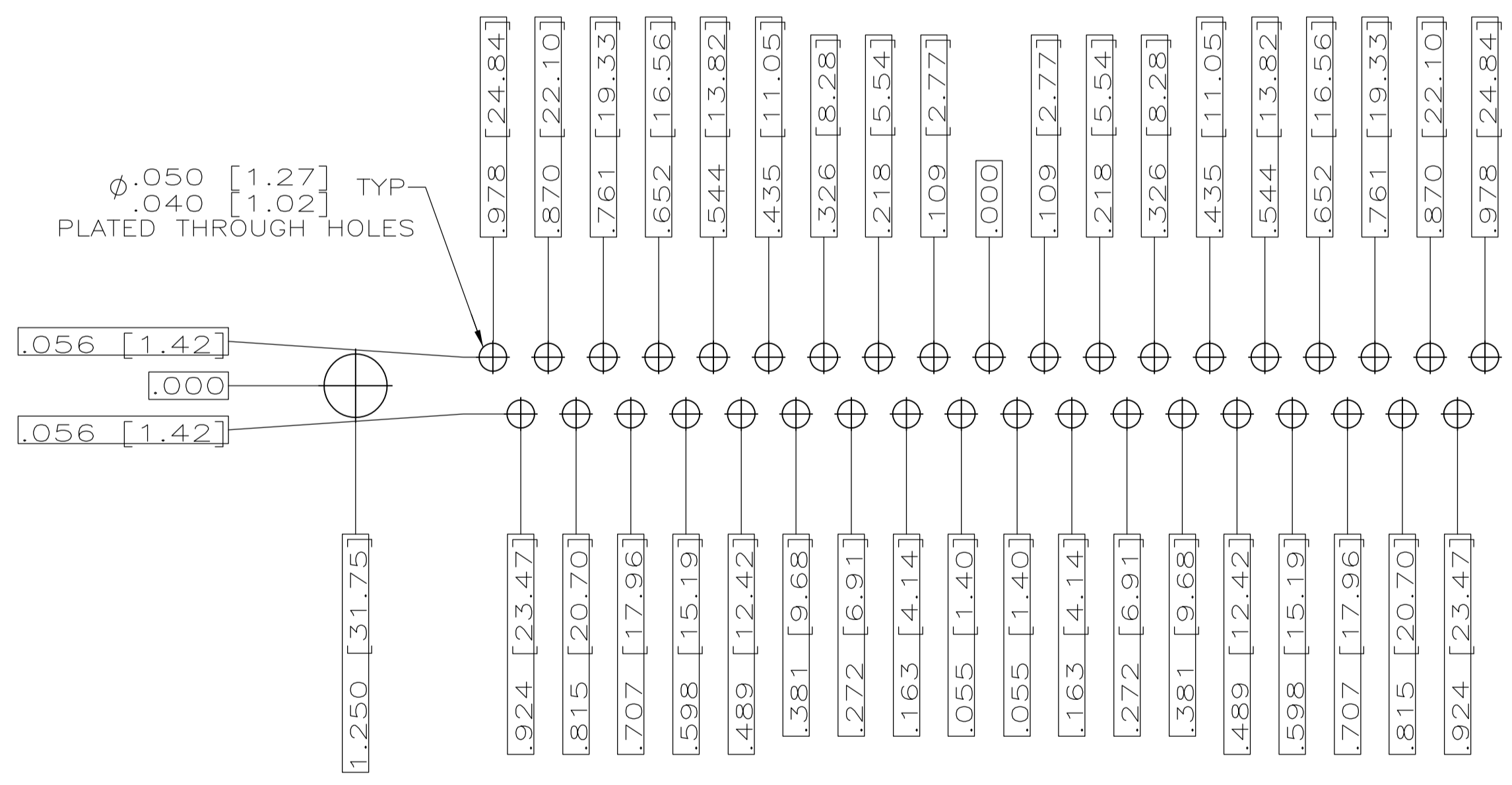

RECOMMENDED P.C. BOARD LAYOUT  
SHELL SIZE 4 (37 POSITION) ⚠

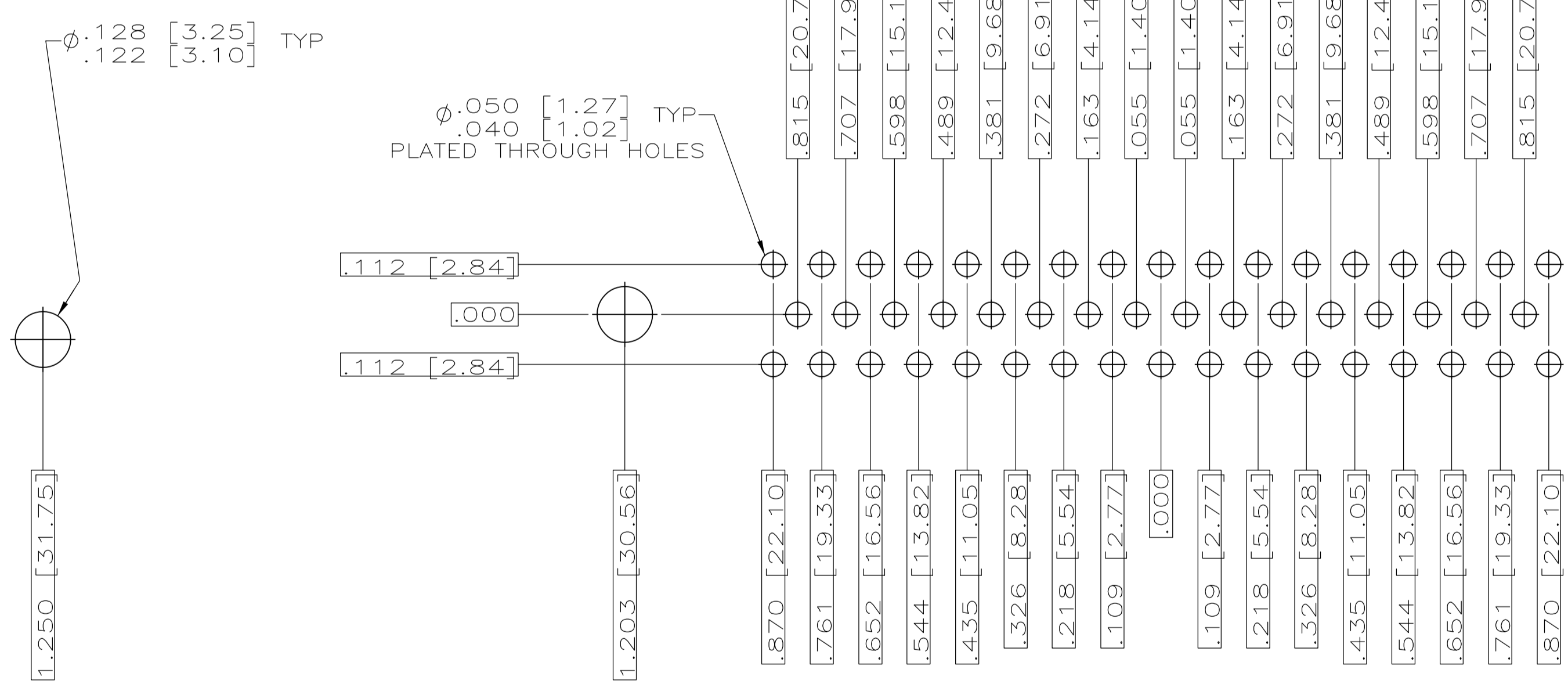

RECOMMENDED P.C. BOARD LAYOUT  
SHELL SIZE 5 (50 POSITION) ⚠

THIS DRAWING IS A CONTROLLED DOCUMENT.		DIN C.C.THOMAS 12-6-99	Tyco Electronics Corporation Tyco Electronics Corporation Harrisburg, PA 17105-3608	
DIMENSIONS: INCHES		CHK CHAD BAKER 12-15-99	NAME CHAD BAKER 12-15-99	
TOLERANCES UNLESS OTHERWISE SPECIFIED: 0 PL ± .005 1 PL ± .005 2 PL ± .005 3 PL ± .005 4 PL ± .005 ANGLES ± .1°		PRODUCT SPEC APPLICATION SPEC		RESTRICTED TO
MATERIAL SEE CALLOUTS		FINISH SEE CALLOUTS	WEIGHT A1 00779	DRAWING NO 1218441
CUSTOMER DRAWING		SCALE 4:1	SHEET 2 OF 2	REV C

Компания «Life Electronics» занимается поставками электронных компонентов импортного и отечественного производства от производителей и со складов крупных дистрибьюторов Европы, Америки и Азии.

С конца 2013 года компания активно расширяет линейку поставок компонентов по направлению коаксиальный кабель, кварцевые генераторы и конденсаторы (керамические, пленочные, электролитические), за счёт заключения дистрибьюторских договоров

Мы предлагаем:

- Конкуренеспособные цены и скидки постоянным клиентам.
- Специальные условия для постоянных клиентов.
- Подбор аналогов.
- Поставку компонентов в любых объемах, удовлетворяющих вашим потребностям.
- Приемлемые сроки поставки, возможна ускоренная поставка.
- Доставку товара в любую точку России и стран СНГ.
- Комплексную поставку.
- Работу по проектам и поставку образцов.
- Формирование склада под заказчика.
- Сертификаты соответствия на поставляемую продукцию (по желанию клиента).
- Тестирование поставляемой продукции.
- Поставку компонентов, требующих военную и космическую приемку.
- Входной контроль качества.
- Наличие сертификата ISO.

В составе нашей компании организован Конструкторский отдел, призванный помогать разработчикам, и инженерам.

Конструкторский отдел помогает осуществить:

- Регистрацию проекта у производителя компонентов.
- Техническую поддержку проекта.
- Защиту от снятия компонента с производства.
- Оценку стоимости проекта по компонентам.
- Изготовление тестовой платы монтаж и пусконаладочные работы.



Тел: +7 (812) 336 43 04 (многоканальный)

Email: [org@lifeelectronics.ru](mailto:org@lifeelectronics.ru)