

System Motor driver IC Series for CD / DVD Players

4ch

System Motor Driver IC



BD8229EFV

No.10011EAT01

●Description

BD8229EFV is BTL driver of 5 input 4 output developed for driving Spindle motor, Sled/Loading motor and the actuator coil. The hysteresis comparator for reset is built in, and the number of parts can reduce.

●Features

- 1) 4CH BTL Driver
- 2) HTSSOP-B24 power package is adopted, the set is miniaturized.
- 3) Has a wide dynamic range (PreVcc=PowVcc=8V,RL=8Ω, 6.0V (typ.))
- 4) Built-in thermal-shut down circuit
- 5) Separating Vcc into Pre and Power (Power divides into CH1/2 and CH3/4), can make better Power efficiency
- 6) Switches CH2 input by Control input terminal (CNT).
- 7) Incorporates mute function by CNT terminal and mute terminal
- 8) Built in hysteresis comparator for reset

●Applications

Car Audio

●Absolute Maximum Ratings

Parameter	Symbol	Limits	Unit
Power supply voltage	PreVcc,PowVcc1, PowVcc2	15	V
Input terminal voltage 1	Vin1 ^{*3}	PreVCC	V
Input terminal voltage 2	Vin2 ^{*4}	PowVCC2	V
Power dissipation	Pd	1.1 ^{*1}	W
		4.0 ^{*2}	
Operating temperature range	Topr	-40~+85	°C
Storage temperature	Tstg	-55~+150	°C
Junction temperature	Tjmax	+150	°C

*1 70mm×70mm×1.6mm,occupied copper foil is less than 3%,glass epoxy standard board) mounting.
Reduce power by 11.6mW for each degree above 25°C.

*2 Exclusive standard board mounting. Reduce power by 32.0mW for each degree above 25°C.

*3 Vin1 Application terminal : IN1, CNT, IN2-1, IN2-2, BIAS, IN3, IN4, MUTE

*4 Vin2 Application terminal : RSTDET

●Recommended Operating Conditions

Parameter	Symbol	Limits	Unit
PRE part Power supply	PreVcc	4.5~14 ^{*5}	V
DC motor system power supply	PowVcc1	4.5~PreVCC ^{*3}	V
Actuator system power supply	PowVcc2	4.5~PreVCC ^{*3}	V

*5 Set the power supply voltage taking allowable dissipation into considering.

●Electrical Characteristics (Unless otherwise noted, Ta=25°C, PreVcc=PowVcc=8V, BIAS=1.65V, RL=8Ω)

Parameter	Symbol	Limits			Unit	Condition
		MIN	TYP	MAX		
Quiescent dissipation current	IQ	—	30	45	mA	At no-load
< Driver >						
Output offset voltage (CH1,2)	Voof 12	-100	0	100	mV	
Output offset voltage (CH3,4)	Voof 34	-50	0	50	mV	
Maximum output amplitude (CH1,2)	VOM 12	5.4	6.0	—	V	
Maximum output amplitude (CH3,4)	VOM 34	4.7	5.3	—	V	
Closed circuit voltage gain (CH1,2)	Gv 12	24.0	25.7	27.4	dB	
Closed circuit voltage gain (CH3,4)	Gv 34	15.5	17.5	19.5	dB	
MUTE terminal low level input voltage	VML	—	—	0.5	V	
MUTE terminal high level input voltage	VMH	2.0	—	—	V	
CNT terminal low level input voltage	VCNTL	—	—	0.5	V	
CNT terminal high level input voltage	VCNTH	2.0	—	—	V	
LDIN terminal voltage (SLED input)	VLDIN	—	0.1	0.3	V	CNT='L'
Internal bias voltage	VBIN	1.53	1.65	1.77	V	CNT='H'
< Reset >						
Reset release voltage	VDET	1.19	1.25	1.31	V	
Hysteresis voltage	VHYS	5	25	55	mV	
Detection terminal outflow current	ICMP	—	50	150	nA	
RSTOUT output Low voltage	VRSTOUT	—	0.1	0.3	V	3.3VPull-up (10kΩ)

●Thermal Derating Curve

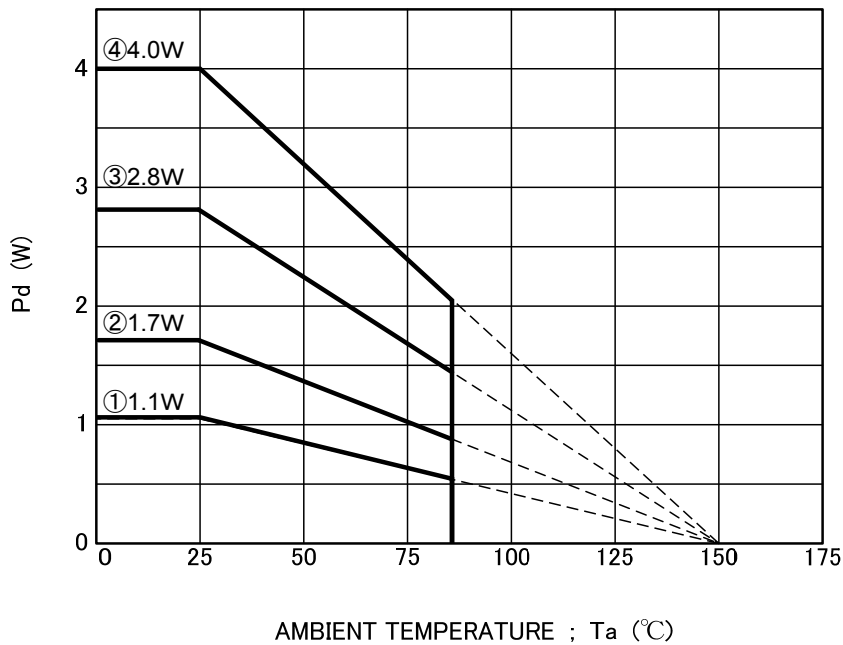

Pd ; power dissipation

Rating for 70mm×70mm(size), 1.6mm(thickness), copper foil occupation ratio less than 3%, and use of glass-epoxy substrate.

Fig.1 Power dissipation

●Package Outlines

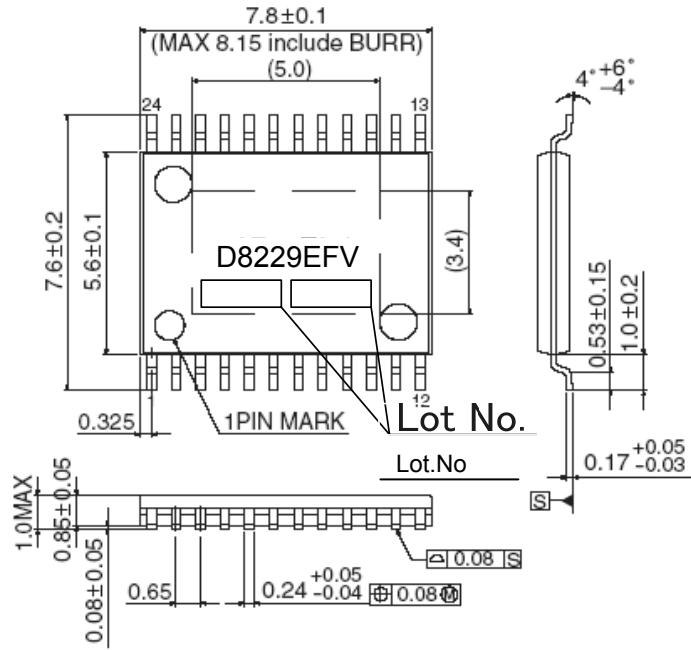

HTSSOP-B24(Unit : mm)

Fig.2 Package Outlines

●Block Diagram

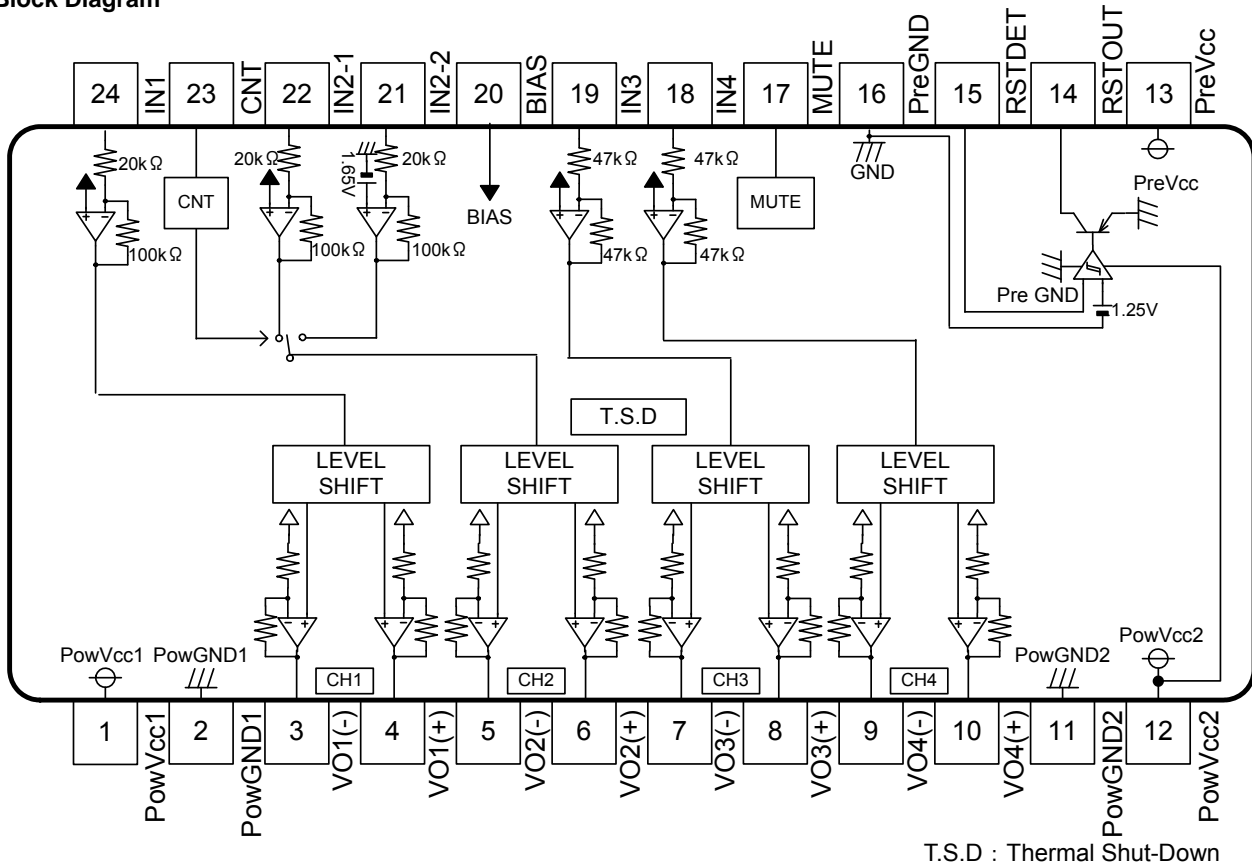

Fig.3:Block Diagram

OPin Descriptions

No.	Symbol	Description	No.	Symbol	Description
1	PowVcc1	CH1,2 power supply terminal	13	PreVcc	Pre,RESET power supply terminal
2	PowGND1	power GND1	14	RSTOUT	Reset output
3	VO1(-)	Driver CH1 negative output	15	RSTDET	Reset detection comparator input
4	VO1(+)	Driver CH1 positive output	16	PreGND	Pre, Reset Block GND
5	VO2(-)	Driver CH2 negative output	17	MUTE	MUTE terminal
6	VO2(+)	Driver CH2 positive output	18	IN4	CH4 input
7	VO3(-)	Driver CH3 negative output	19	IN3	CH3 input
8	VO3(+)	Driver CH3 positive output	20	BIAS	BIAS input terminal
9	VO4(-)	Driver CH4 negative output	21	IN2-2	CH2-2 input
10	VO4(+)	Driver CH4 positive output	22	IN2-1	CH2-1 input
11	PowGND2	power GND2	23	CNT	Control input terminal
12	PowVcc2	CH3,4 power supply terminal	24	IN1	IN1 input

●Functional Description

1.The driver can put the mute by switching the terminal MUTE and the terminal CNT to High level and Low level.
The table below shows the logic.

INPUT		OUTPUT	
MUTE	CNT	CH1,3,4	CH2
H	H	ACTIVE	LD ON
H	L	ACTIVE	SL ON
L	H	MUTE	LD ON
L	L	MUTE	MUTE

SL : SLED LD : Loading

- The mute works when the bias terminal (20PIN) becomes 0.7V(typ.) or less. Please set it to 1.3V or more in the state of use normally.(However, the mute doesn't work as for CH2 at CNT='H'.)
- When the power-supply voltage becomes 3.8V(typ.) or less, the output terminal becomes the state of the mute.
When the power-supply voltage rises up to 4.0V again, the driver part circuit stands up
- The threshold voltage of PowVcc2 reset can be calculated by the following expressions.

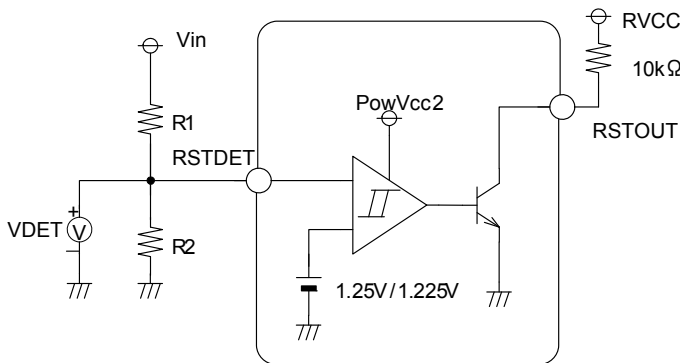

$$V_{in} = \frac{R1+R2}{R2} \times V_{DET}$$

- The threshold voltage of PowVcc2 reset can be changed by external resistance R1 and R2.
R1 and R2 recommend the resistance of 100kΩ or less respectively.
- Please make below the voltage of PowVcc2(PIN12) the voltage of the RSTOUT output terminal that is the pull-up (RVCC).
- The characteristic chart of RSTDET and RSTOUT is shown as follows.

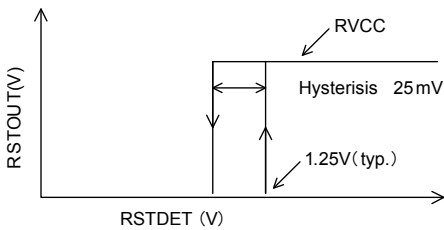

●Example of Recommended Circuit

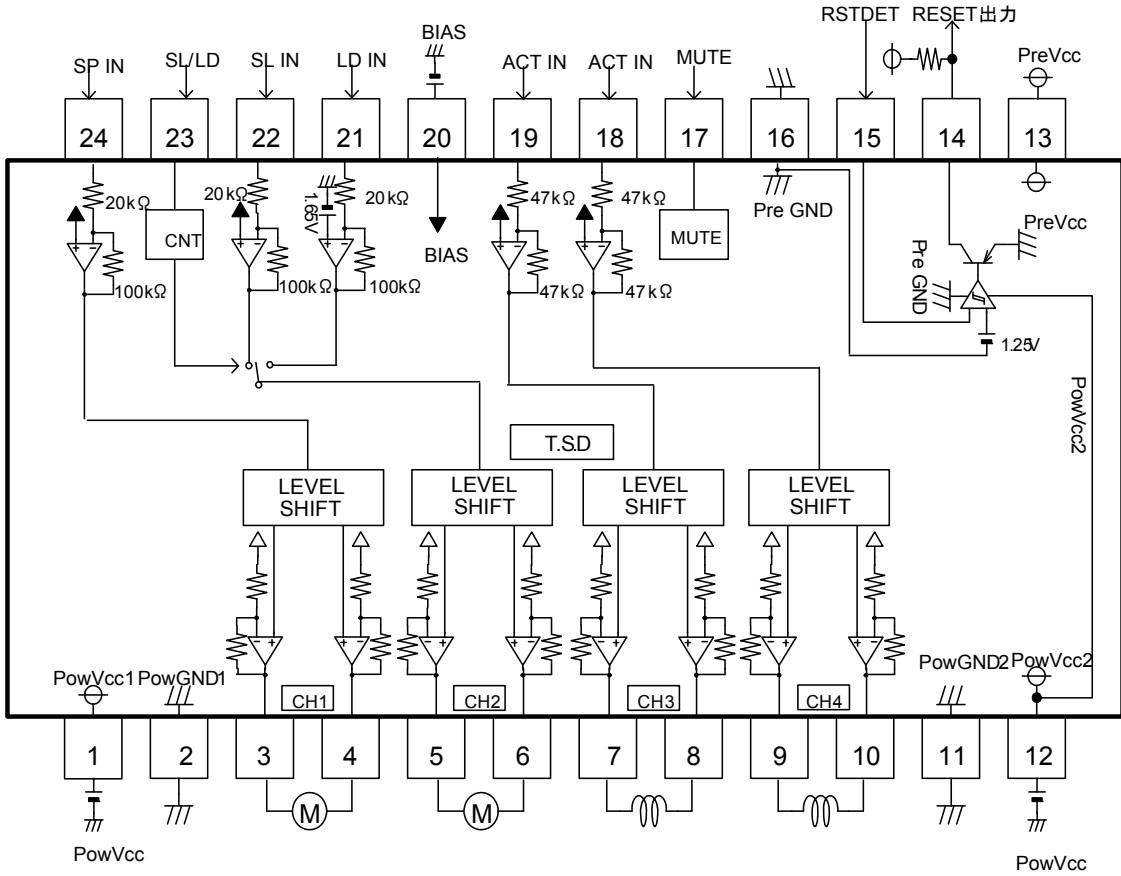

Fig.4:Application circuit

●The Picture of Application Board Wire Connection (Reference for BD8229EFV)

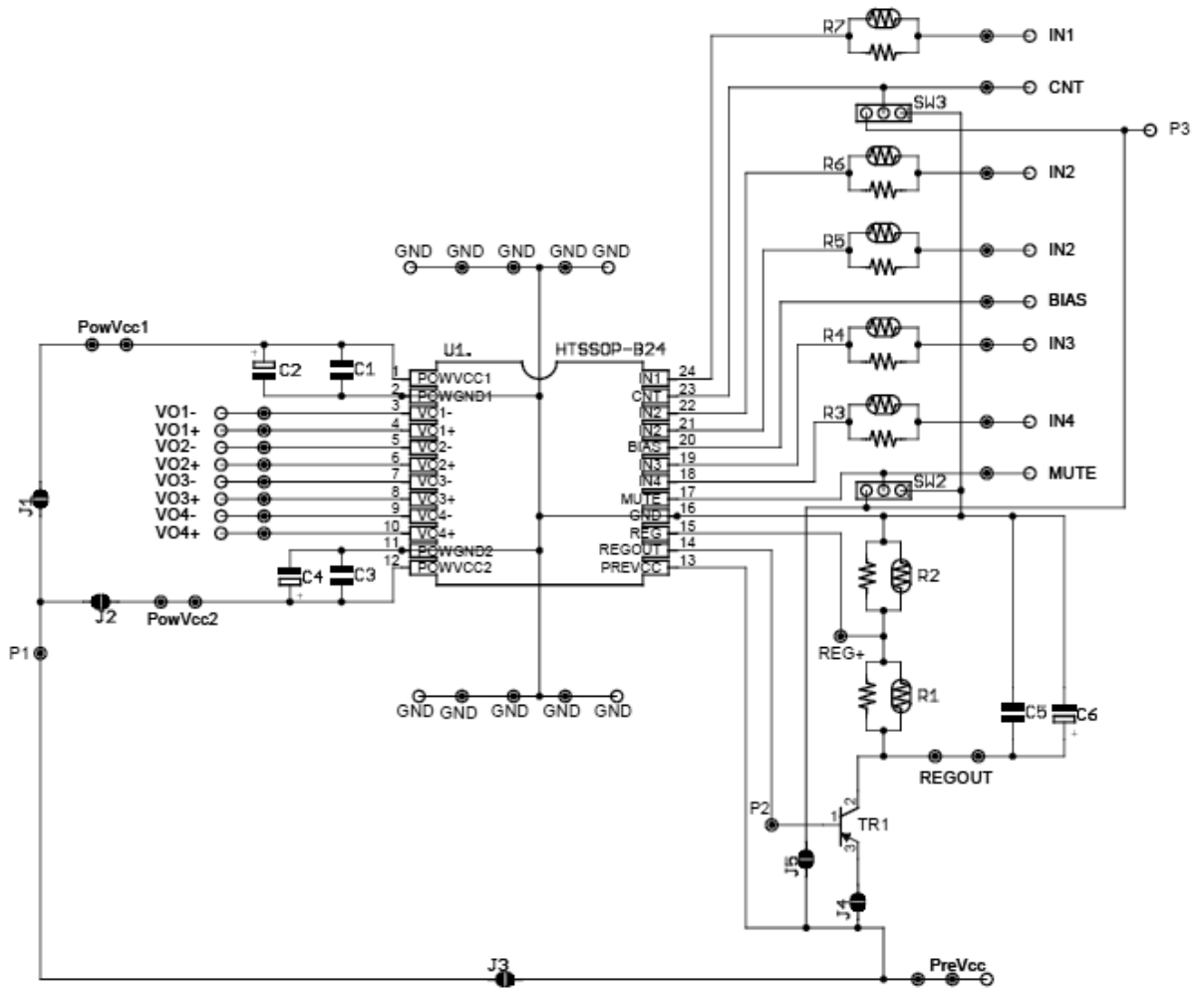
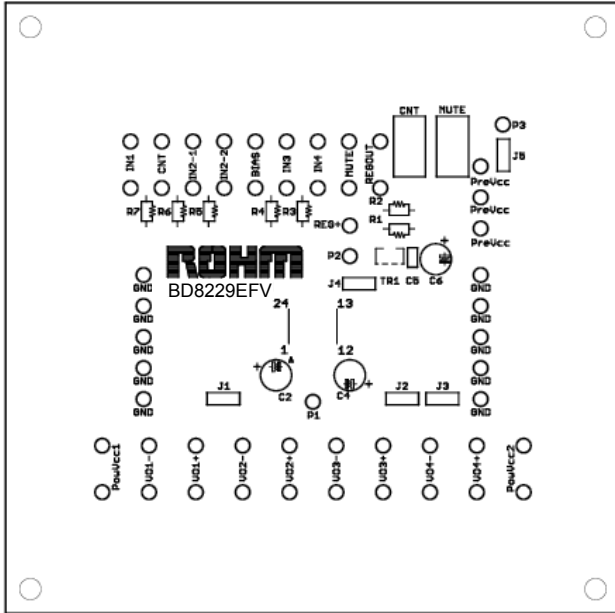
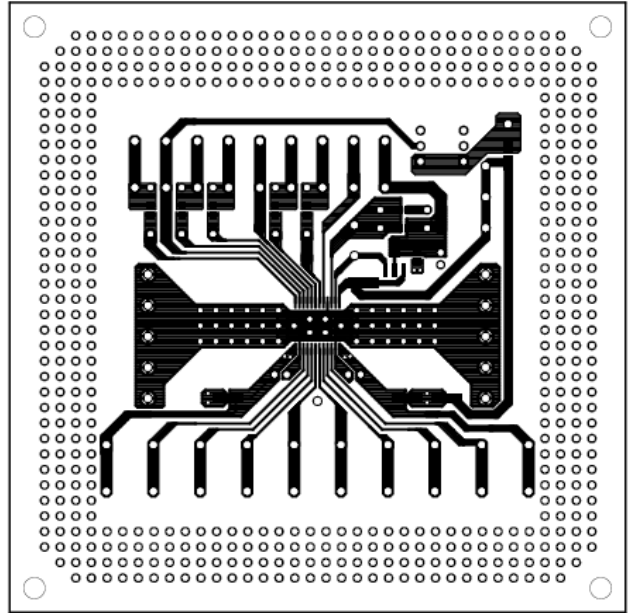

Fig.5. application board wire connection

●The Picture of Application Board Pattern (Reference for BD8229EFV)



Top Silkscreen Overlay



Top Layer

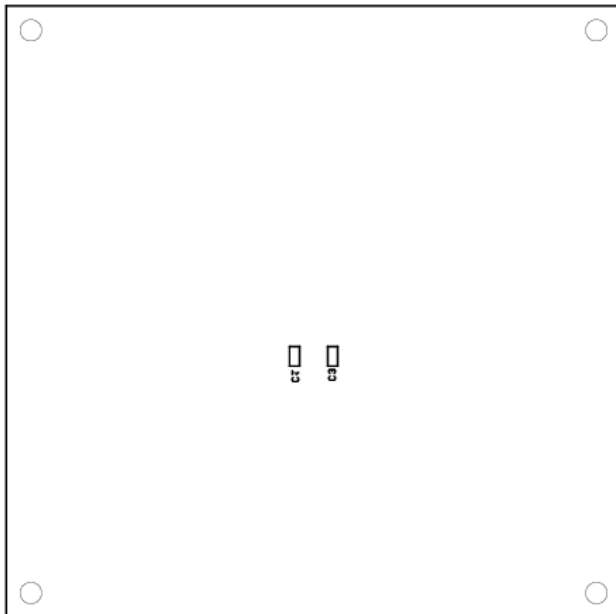

Bottom Silkscreen Overlay

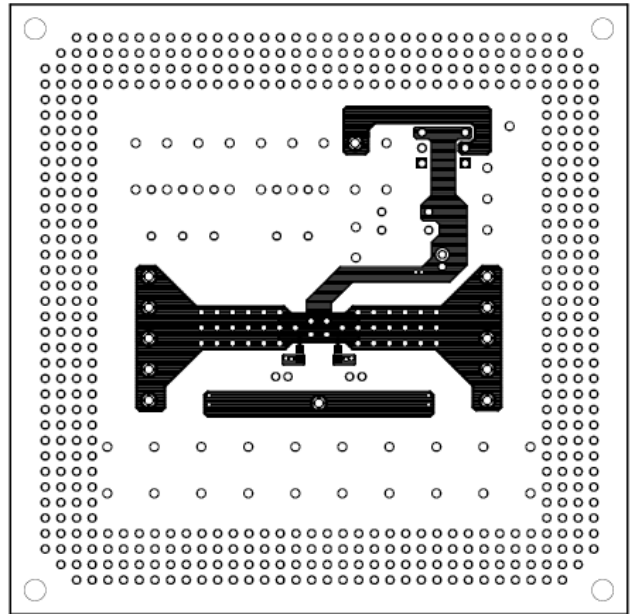

Bottom Layer

● Terminal Equivalent Circuit

Bias terminal		Input terminal	
Driver output		Input terminal	
Mute		Input terminal	
Control		Input terminal	
Driver output		Input terminal	
Reset output		Reset detection Comparator input	

※Resistance in the above-mentioned terminal equivalent circuit chart is 25°C, and a value at typical.

●Notes for use

1. Absolute maximum ratings

We are careful enough for quality control about this IC. So, there is no problem under normal operation, excluding that it exceeds the absolute maximum ratings. However, this IC might be destroyed when the absolute maximum ratings, such as impressed voltages or the operating temperature range, is exceeded, and whether the destruction is short circuit mode or open circuit mode cannot be specified. Please take into consideration the physical countermeasures for safety, such as fusing, if a particular mode that exceeds the absolute maximum rating is assumed.

2. Reverse polarity connection

Connecting the power line to the IC in reverse polarity (from that recommended) will damage the part. Please utilize the direction protection device as a diode in the supply line and motor coil line.

3. Power supply line

Due to return of regenerative current by reverse electromotive force, using electrolytic and ceramic suppress filter capacitors (0.1 μ F) close to the IC power input terminals (Vcc and GND) are recommended. Please note the electrolytic capacitor value decreases at lower temperatures and examine to dispense physical measures for safety. And, for ICs with more than one power supply, it is possible that rush current may flow instantaneously due to the internal powering sequence and delays. Therefore, give special consideration to power coupling capacitance, power wiring, width of GND wiring, and routing of wiring.

4. GND line

Please keep the GND line the lowest potential always, and check the GND voltage when transient voltages are connected to the IC.

5. Thermal design

Do not exceed the power dissipation (Pd) of the package specification rating under actual operation, and please design enough temperature margins. This product has exposed the frame to the back side of the package, but please note that it is assumed to use heat radiation efficiency by the heat radiation for this part. Please take the heat radiation pattern on not only the surface of the substrate but also the back of the substrate widely.

6. Short circuit mode between terminals and wrong mounting

Do not mount the IC in the wrong direction and displacement, and be careful about the reverse-connection of the power connector. Moreover, this IC might be destroyed when the dust short the terminals between them or GND.

7. Radiation

Strong electromagnetic radiation can cause operation failures.

8. ASO (Area of Safety Operation)

Do not exceed the maximum ASO and the absolute maximum ratings of the output driver.

9. TSD (Thermal Shut-Down)

The TSD is activated when the junction temperature (Tj) exceeds Tjmax, and the output terminal is switched to OPEN. The guarantee and protection of set are not purpose. Therefore, please do not use this IC after TSD circuit operates, nor use it for assumption that operates the TSD circuit.

10. Capacitor between output driver and GND

If a large capacitor is connected between the output driver and GND, this IC might be destroyed when Vcc becomes 0V or GND, because the electric charge accumulated in the capacitor flows to the output driver. Please set said capacitor to smaller than 0.1 μ F.

11. Inspection by the set circuit board

The stress might hang to IC by connecting the capacitor to the terminal with low impedance. Then, please discharge electricity in each and all process. Moreover, when attaching or detaching from jig in the inspection process, please turn off the power before mounting the IC, and turn on after mounting the IC, and vice versa. In addition, please take into consideration the countermeasures for electrostatic damage, such as giving the earth in assembly process, transportation or preservation.

12. Input terminal

This IC is a monolithic IC, and has P⁺ isolation and P substrate for the element separation. Therefore, a parasitic PN junction is formed in this P-layer and N-layer of each element. For instance, the resistor or the transistor is connected to the terminal as shown in the figure below. When the GND voltage potential is greater than the voltage potential at Terminal A on the resistor, at Terminal B on the transistor, the PN junction operates as a parasitic diode. In addition, the parasitic NPN transistor is formed in said parasitic diode and the N layer of surrounding elements close to said parasitic diode. These parasitic elements are formed in the IC because of the voltage relation. The parasitic element operating causes the interference of circuit operation, then the wrong operation and destruction. Therefore, please be careful so as not to operate the parasitic elements by impressing to input terminals lower voltage than GND (P substrate). Please do not apply the voltage to the input terminal when the power-supply voltage is not impressed. Moreover, please impress each input terminal lower than the power-supply voltage or equal to the specified range in the guaranteed voltage when the power-supply voltage is impressing.

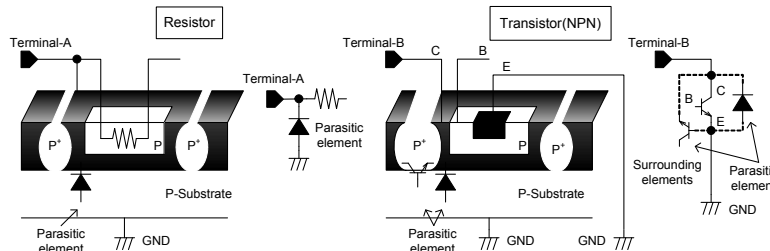

Simplified structure of IC

13. Earth wiring pattern

If small signal GND and large current GND exist, disperse their pattern. In addition, for voltage change by pattern wiring impedance and large current not to change voltage of small signal GND, each ground terminal of IC must be connected at the one point on the set circuit board. As for GND of external parts, it is similar to the above-mentioned.

14. Please make below the voltage of PowVcc2(PIN12) the voltage of the RSTOUT output terminal that is the pull-up (RVCC).

●Ordering part number

B	D
---	---

Part No.

8	2	2	9
---	---	---	---

Part No.

E	F	V
---	---	---

Package
EFV: HTSSOP-B24

E	2
---	---

Packaging and forming specification
E2: Embossed tape and reel

SSOP-B24

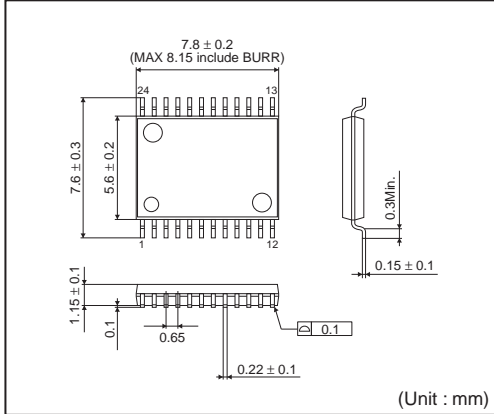

<Tape and Reel information>

Tape	Embossed carrier tape
Quantity	2000pcs
Direction of feed	E2 (The direction is the 1pin of product is at the upper left when you hold reel on the left hand and you pull out the tape on the right hand)

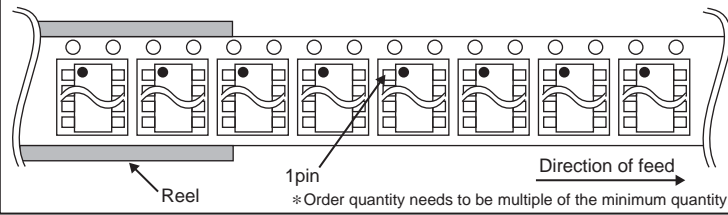

Notes

No copying or reproduction of this document, in part or in whole, is permitted without the consent of ROHM Co.,Ltd.

The content specified herein is subject to change for improvement without notice.

The content specified herein is for the purpose of introducing ROHM's products (hereinafter "Products"). If you wish to use any such Product, please be sure to refer to the specifications, which can be obtained from ROHM upon request.

Examples of application circuits, circuit constants and any other information contained herein illustrate the standard usage and operations of the Products. The peripheral conditions must be taken into account when designing circuits for mass production.

Great care was taken in ensuring the accuracy of the information specified in this document. However, should you incur any damage arising from any inaccuracy or misprint of such information, ROHM shall bear no responsibility for such damage.

The technical information specified herein is intended only to show the typical functions of and examples of application circuits for the Products. ROHM does not grant you, explicitly or implicitly, any license to use or exercise intellectual property or other rights held by ROHM and other parties. ROHM shall bear no responsibility whatsoever for any dispute arising from the use of such technical information.

The Products specified in this document are intended to be used with general-use electronic equipment or devices (such as audio visual equipment, office-automation equipment, communication devices, electronic appliances and amusement devices).

The Products specified in this document are not designed to be radiation tolerant.

While ROHM always makes efforts to enhance the quality and reliability of its Products, a Product may fail or malfunction for a variety of reasons.

Please be sure to implement in your equipment using the Products safety measures to guard against the possibility of physical injury, fire or any other damage caused in the event of the failure of any Product, such as derating, redundancy, fire control and fail-safe designs. ROHM shall bear no responsibility whatsoever for your use of any Product outside of the prescribed scope or not in accordance with the instruction manual.

The Products are not designed or manufactured to be used with any equipment, device or system which requires an extremely high level of reliability the failure or malfunction of which may result in a direct threat to human life or create a risk of human injury (such as a medical instrument, transportation equipment, aerospace machinery, nuclear-reactor controller, fuel-controller or other safety device). ROHM shall bear no responsibility in any way for use of any of the Products for the above special purposes. If a Product is intended to be used for any such special purpose, please contact a ROHM sales representative before purchasing.

If you intend to export or ship overseas any Product or technology specified herein that may be controlled under the Foreign Exchange and the Foreign Trade Law, you will be required to obtain a license or permit under the Law.



Thank you for your accessing to ROHM product informations.
More detail product informations and catalogs are available, please contact us.

ROHM Customer Support System

<http://www.rohm.com/contact/>

Компания «Life Electronics» занимается поставками электронных компонентов импортного и отечественного производства от производителей и со складов крупных дистрибьюторов Европы, Америки и Азии.

С конца 2013 года компания активно расширяет линейку поставок компонентов по направлению коаксиальный кабель, кварцевые генераторы и конденсаторы (керамические, пленочные, электролитические), за счёт заключения дистрибьюторских договоров

Мы предлагаем:

- Конкурентоспособные цены и скидки постоянным клиентам.
- Специальные условия для постоянных клиентов.
- Подбор аналогов.
- Поставку компонентов в любых объемах, удовлетворяющих вашим потребностям.
- Приемлемые сроки поставки, возможна ускоренная поставка.
- Доставку товара в любую точку России и стран СНГ.
- Комплексную поставку.
- Работу по проектам и поставку образцов.
- Формирование склада под заказчика.
- Сертификаты соответствия на поставляемую продукцию (по желанию клиента).
- Тестирование поставляемой продукции.
- Поставку компонентов, требующих военную и космическую приемку.
- Входной контроль качества.
- Наличие сертификата ISO.

В составе нашей компании организован Конструкторский отдел, призванный помогать разработчикам, и инженерам.

Конструкторский отдел помогает осуществить:

- Регистрацию проекта у производителя компонентов.
- Техническую поддержку проекта.
- Защиту от снятия компонента с производства.
- Оценку стоимости проекта по компонентам.
- Изготовление тестовой платы монтаж и пусконаладочные работы.



Тел: +7 (812) 336 43 04 (многоканальный)
Email: org@lifeelectronics.ru