

# POWER RELAY

## 1 POLE - 30A DC Relay

### 2 x 3.2mm contact gap

## FTR-K2W Series

#### ■ FEATURES

- Contact rating: 60VDC, 30A; 72VDC, 25A
- Wide contact gap: 2 x 3.2mm
- Compact size: 36.5 (L) x 34.9 (W) x 30.2 (H) mm
- 1 form A contact
- High insulation (between coil and contact)
  - Insulation distance: Clearance > 8.0mm  
Creepage > 9.5mm
  - Dielectric strength: 5,000VAC
  - Surge strength: 10,000V
- Flammability UL94V-0 (plastics)
- RoHS compliant  
Please see page 6 for more information



#### ■ PARTNUMBER INFORMATION

[Example]     FTR-K2W   A   K   012   W  
                   (a)    (b)   (c)   (d)   (e)

(a)	Relay type	FTR-K2W : FTR-K2W-Series
(b)	Contact configuration	A        : 1 form A
(c)	Coil type	K        : Standard (2,000mW)
(d)	Coil rated voltage	12      : 5.....24 VDC Coil rating table at page 3
(e)	Contact material	W        : Silver alloy

Actual marking does not carry the type name : "FTR"  
 E.g.: Ordering code: FTR-K2WAK012W Actual marking: K2WAK012W

# FTR-K2W SERIES

## ■ SPECIFICATION

Item	FTR-K2W		
Contact Data	Configuration	1 form A	
	Material	Silver alloy	
	Resistance (initial)	Max. 100mOhm at 1A, 6VDC	
	Contact rating	30A / 60VDC, 25A / 72VDC (resistive)	
Life	Mechanical	Min. 1 x 10 <sup>6</sup> operations	
	Electrical	10 x 10 <sup>3</sup> operations	
Coil Data	Rated power (at 20 °C)	Approximately 2,000mW	
	Nominal voltage	5, 12, 24, 48VDC	
	Operating temperature range	-40 °C to +70 °C (no frost)	
Timing Data	Operate (at nominal voltage)	Max. 30ms (without bounce)	
	Release	Max. 15ms (no diode)	
Insulation	Resistance (initial)	Min. 1,000MOhm at 500VDC	
	Dielectric strength	Open contacts	2,000VAC (50/60 Hz) 1min.
		Coil and contacts	5,000VAC (50/60 Hz) 1min.
	Surge strength	Coil to contacts	10,000V / 1.2 x 50µs standard wave
	Clearance		≥ 8 mm
Creepage		≥ 9.5 mm	
Other	Vibration resistance	Misoperation	10 to 55Hz double amplitude 1.5 mm
		Endurance	10 to 55Hz double amplitude 1.5 mm
	Shock resistance	Misoperation	Min. 100m/s <sup>2</sup> (11 ± 1ms)
		Endurance	Min. 1,000m/s <sup>2</sup> (6 ± 1ms)
	Weight		Approximately 74 g
Sealing		Flux proof, RT II	

### Notes:

1. To prevent hazardous situation in case of catastrophic contact failures like contact welding, please carefully evaluate the relay application parameters, to assure a fail-safe design. This is particularly important in case of over spec use and long periods of continuous use.
2. Use of a varistor in parallel over the coil is recommended to clamp reverse inductive voltage surges. Reverse blocking voltage should be about 3 times the surge voltage level.
3. A contact carrying currents higher than 10A, it is recommended to consider addition heat develop in the PCB contact tracks.
4. Specified values are valid in case of series connection of coils, by connecting pin 2 and 3, at Tamb 20°C and at zero contact current.

## ■ COIL RATING

Coil Code	Rated Coil Voltage (VDC)	Coil Resistance +/- 10% (Ohm)	Must Operate Voltage (VDC) *	Must Release-Voltage (VDC) *	Rated Power +/- 10% (mW)
005	5	12.5	3.25	0.25	Approx. 2,000
012	12	72	7.8	0.6	
024	24	290	15.6	1.2	
048	48	1,160	31.2	2.4	

Notes:

- 1) Specified values are valid in case of series connection of coils, by connecting pin 2 and 3, at Tamb 20°C and at zero contact current.
- 2) Normal use it at nominal coil voltage. If the relay is energized at higher coil voltage, refer to data "coil temperature rise"

\*Specified operate- and must release voltage are valid for pulse wave voltages.

## ■ SAFETY STANDARDS

Type	Compliance	Contact rating
UL	UL 508 CSA22.2 No. 14-05	30A, 60VDC, resistive, 10,000 cycles
TUV	EN61810-1 / IEC61810-1	30A, 60VDC, resistive, 10,000 cycles

# FTR-K2W SERIES

## ■ CHARACTERISTIC DATA

The graphs are based on measurement data and are typical values.

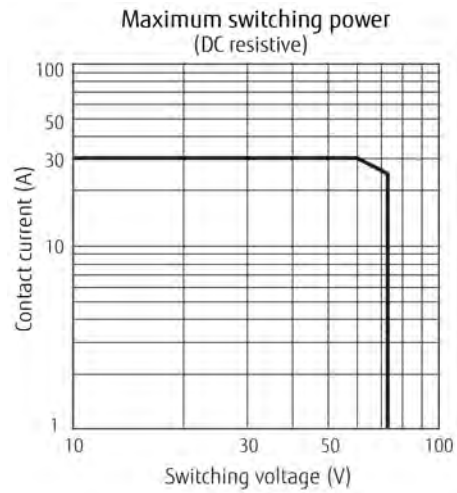
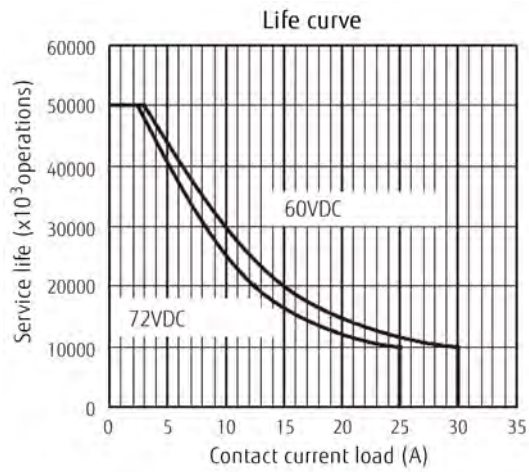
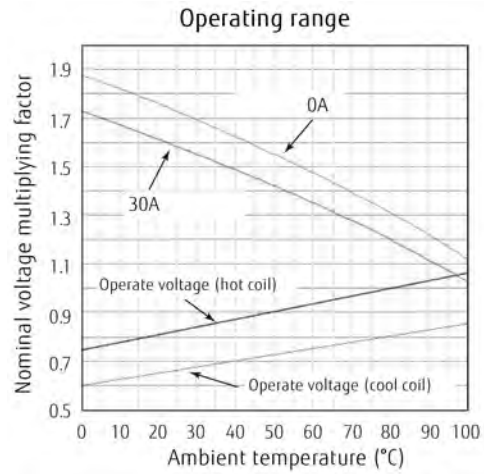
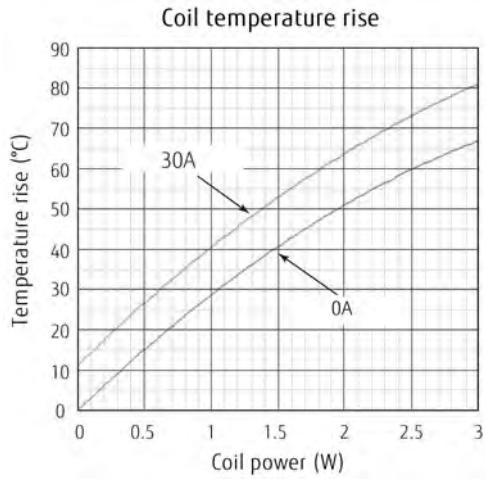

Please use this graph for reference purposes

## ■ DIMENSIONS

### ● Dimensions

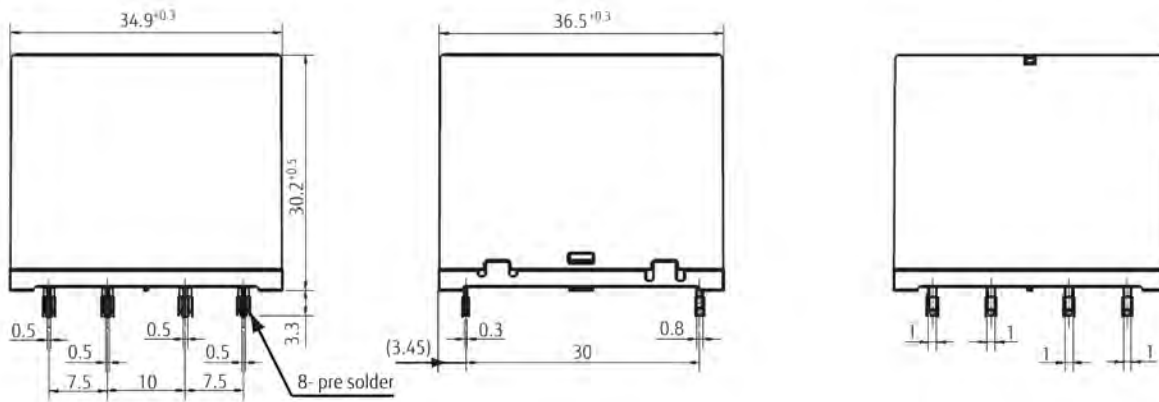

### ● Schematics (BOTTOM VIEW)

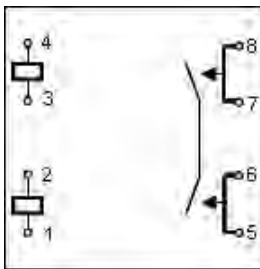

### ● Circuit (BOTTOM VIEW)

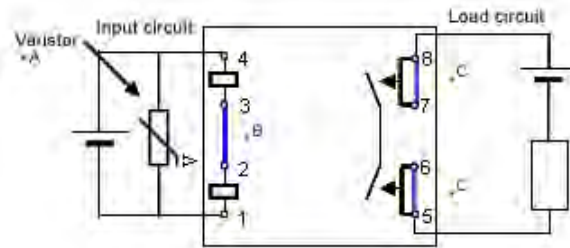

### ● PC board pattern (BOTTOM VIEW)

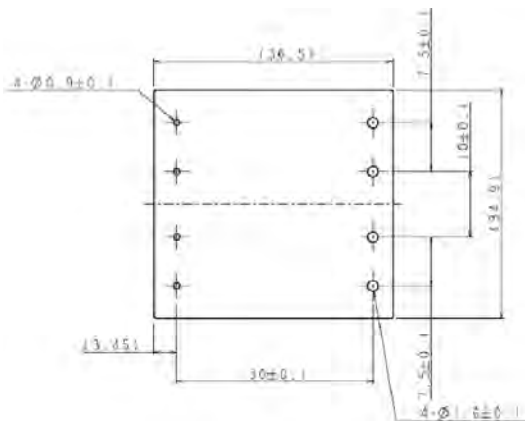

### Notes:

- Use of a varistor in parallel over the coil is recommended to clamp reverse inductive voltage surges. Reverse blocking voltage should be about 3 times the surge voltage level.
- Connect pin 2 and 3 to connect coils in series.
- To enhance a current carry capability, connect pin 5 with 6 and pin 7 with 8.
- Coils are polarity insensitive.

Unit: mm

## RoHS Compliance and Lead Free Information

### 1. General Information

- All signal and power relays produced by Fujitsu Components are compliant with RoHS directive 2002/95EC including amendments.
- Cadmium as used in electrical contacts is exempted from the RoHS directives on October 21st, 2005. (Amendment to Directive 2002/95/EC)
- All of our signal and power relays are lead-free. Please refer to Lead-Free Status Info for older date codes at: <http://www.fujitsu.com/us/downloads/MICRO/fcai/relays/lead-free-letter.pdf>
- Lead free solder plating on relay terminals is Sn-3.0Ag-0.5Cu, unless otherwise specified. This material has been verified to be compatible with PbSn assembly process.

### 2. Recommended Lead Free Solder Profile

- **Recommended solder Sn-3.0Ag-0.5Cu.**

#### **Flow Solder condition:**

Pre-heating: maximum 120°C  
Soldering: dip within 5 sec. at  
260°C solder bath

#### **Solder by Soldering Iron:**

Soldering Iron  
Temperature: maximum 360°C  
Duration: maximum 3 sec.

**We highly recommend that you confirm your actual solder conditions**

### 3. Moisture Sensitivity

- Moisture Sensitivity Level standard is not applicable to electromechanical relays, unless otherwise indicated.

### 4. Tin Whiskers

- Dipped SnAgCu solder is known as presenting a low risk to tin whisker development. No considerable length whisker was found by our in house test.

## Fujitsu Components International Headquarter Offices

### Japan

Fujitsu Component Limited  
Gotanda-Chuo Building  
3-5, Higashigotanda 2-chome, Shinagawa-ku  
Tokyo 141, Japan  
Tel: (81-3) 5449-7010  
Fax: (81-3) 5449-2626  
Email: [promothq@ft.ed.fujitsu.com](mailto:promothq@ft.ed.fujitsu.com)  
Web: [www.fcl.fujitsu.com](http://www.fcl.fujitsu.com)

### North and South America

Fujitsu Components America, Inc.  
250 E. Caribbean Drive  
Sunnyvale, CA 94089 U.S.A.  
Tel: (1-408) 745-4900  
Fax: (1-408) 745-4970  
Email: [components@us.fujitsu.com](mailto:components@us.fujitsu.com)  
Web: <http://us.fujitsu.com/components>

### Europe

Fujitsu Components Europe B.V.  
Diamantlaan 25  
2132 WV Hoofddorp  
Netherlands  
Tel: (31-23) 5560910  
Fax: (31-23) 5560950  
Email: [info@fceu.fujitsu.com](mailto:info@fceu.fujitsu.com)  
Web: [emea.fujitsu.com/components/](http://emea.fujitsu.com/components/)

### Asia Pacific

Fujitsu Components Asia Ltd.  
102E Pasir Panjang Road  
#01-01 Citilink Warehouse Complex  
Singapore 118529  
Tel: (65) 6375-8560  
Fax: (65) 6273-3021  
Email: [fcalfcal.fujitsu.com](mailto:fcalfcal.fujitsu.com)  
Web: <http://www.fujitsu.com/sg/services/micro/components/>

©2012 Fujitsu Components Europe B.V. All rights reserved. All trademarks or registered trademarks are the property of their respective owners.

The contents, data and information in this datasheet are provided by Fujitsu Component Ltd. as a service only to its user and only for general information purposes.

The use of the contents, data and information provided in this datasheet is at the users' own risk.

Fujitsu has assembled this datasheet with care and will endeavor to keep the contents, data and information correct, accurate, comprehensive, complete and up to date.

Fujitsu Components Europe B.V. and affiliated companies do however not accept any responsibility or liability on their behalf, nor on behalf of its employees, for any loss or damage, direct, indirect or consequential, with respect to this datasheet, its contents, data, and information and related graphics and the correctness, reliability, accuracy, comprehensiveness, usefulness, availability and completeness thereof.

Nor do Fujitsu Components Europe B.V. and affiliated companies accept on their behalf, nor on behalf of its employees, any responsibility or liability for any representation or warrant of any kind, express or implied, including warranties of any kind for merchantability or fitness for particular use, with respect to these datasheets, its contents, data, information and related graphics and the correctness, reliability, accuracy, comprehensiveness, usefulness, availability and completeness thereof. Rev. December 18, 2012

Компания «Life Electronics» занимается поставками электронных компонентов импортного и отечественного производства от производителей и со складов крупных дистрибьюторов Европы, Америки и Азии.

С конца 2013 года компания активно расширяет линейку поставок компонентов по направлению коаксиальный кабель, кварцевые генераторы и конденсаторы (керамические, пленочные, электролитические), за счёт заключения дистрибьюторских договоров

Мы предлагаем:

- Конкурентоспособные цены и скидки постоянным клиентам.
- Специальные условия для постоянных клиентов.
- Подбор аналогов.
- Поставку компонентов в любых объемах, удовлетворяющих вашим потребностям.
- Приемлемые сроки поставки, возможна ускоренная поставка.
- Доставку товара в любую точку России и стран СНГ.
- Комплексную поставку.
- Работу по проектам и поставку образцов.
- Формирование склада под заказчика.
- Сертификаты соответствия на поставляемую продукцию (по желанию клиента).
- Тестирование поставляемой продукции.
- Поставку компонентов, требующих военную и космическую приемку.
- Входной контроль качества.
- Наличие сертификата ISO.

В составе нашей компании организован Конструкторский отдел, призванный помогать разработчикам, и инженерам.

Конструкторский отдел помогает осуществить:

- Регистрацию проекта у производителя компонентов.
- Техническую поддержку проекта.
- Защиту от снятия компонента с производства.
- Оценку стоимости проекта по компонентам.
- Изготовление тестовой платы монтаж и пусконаладочные работы.



Тел: +7 (812) 336 43 04 (многоканальный)  
Email: [org@lifeelectronics.ru](mailto:org@lifeelectronics.ru)