

ECP-E...

Electronic circuit breaker



CLIPLINE

Data sheet
102898_en_03

© PHOENIX CONTACT 2010-12-17

1 Description

The **ECP-E...** electronic circuit breaker can be used in applications that cover all aspects of the switched-mode power supply unit.

In the event of an overload, switched-mode power supply units reduce their output voltage, which means that all the connected loads are no longer sufficiently supplied, e.g., in the event of a short circuit at the load.

The solution here is the ECP-E... electronic circuit breaker, which selectively protects all 24 V DC load circuits. The ECP-E... constantly limits the residual current to 1.8 times (or 1.5/1.3 times) the protected nominal current. Capacitive loads can thus be switched on and loads are only switched off in the event of an overload or short circuit.

After detecting an overload or short circuit in the load circuit, the load output of the ECP-E... is disabled. The current flow in the faulty circuit is interrupted. The ECP-E... and therefore the circuit can be activated again via the electronic reset input (13;14) or manually on the device via the slide switch.

A multi-color LED and the integrated status output (12) indicate the operating or error state.

The ECP-E... offers quick and space-saving assembly, as it can be plugged onto the TMCP SOCKET M and has a low design width of just 12.5 mm.

1.1 Properties

- Selective load protection, electronic shutdown characteristic curve
- Active current limitation when switching on capacitive loads up to 20,000 μ F and in the event of overload/short circuit
- Nominal current can be selected in fixed current strengths from 1 A ... 12 A
- Safe overload shutdown from $1.1 \times I_N$, even for long load cables or low cable cross-sections
- Manual on/off switch (S1)
- Indication by means of LED, status output SF
- Electronic reset input RE
- Integrated failsafe element
- Design width of just 12.5 mm per channel
- Can be plugged into a modular base



NOTE: Make sure that the cable cross-section of the relevant load circuit is adapted to the nominal current of the ECP-E... used.

In the system or machine, take special precautionary measures to prevent system parts from restarting (according to Machinery Directive 2006/42/EC and EN 60204-1). In the event of an error (short circuit/overload), the load circuit is electronically shut down by the ECP-E....



NOTE: Make sure that the cable cross-section of the relevant load circuit is adapted to the nominal current of the ECP-E... used.



Make sure you always use the latest documentation.
It can be downloaded at www.phoenixcontact.net/catalog.



This data sheet is valid for all products listed on the following page:

2 Ordering data

Electronic circuit breaker

Description	Type	Order No.	Pcs./Pkt.
Electronic circuit breaker, standard version with status output and reset input, can be plugged into a TMCP base, indication by means of 3-color LED			
1 A nominal current	ECP-E 1A	0900113	5
2 A nominal current	ECP-E 2A	0900210	5
3 A nominal current	ECP-E 3A	0900317	5
4 A nominal current	ECP-E 4A	0900414	5
6 A nominal current	ECP-E 6A	0900618	5
8 A nominal current	ECP-E 8A	0900812	5
10 A nominal current	ECP-E 10A	0901002	5
12 A nominal current	ECP-E 12A	0900126	5

Accessories

Description	Type	Order No.	Pcs./Pkt.
Modular base , 2-pos., designed to accommodate two 1-pos. circuit breakers, width of 12.5 mm per position	TMCP SOCKET M	0916589	10
Base termination elements , can be plugged into both the left and right-hand side, contain the connections for the reset inputs/group query	TMCP CONNECT LR	0916592	3
Spring lock , for mechanical locking if mounted overhead, 1-pos.	ECP-LOCK	0912021	10
Zack marker strip , 10-section, for labeling the center of the terminal block	ZB 6	See CLIPLINE catalog	
Fixed bridge , plug-in, not insulated, 500 mm long, can be cut to length, for distribution of the supply potential in the base, $I_{max} = 50 A$	FBST 500 TMCP	0916615	20
Continuous plug-in bridge , 500 m long, can be cut to length, for potential distribution, $I_{max} = 32 A$, red	FBST 500-PLC RD	2966786	20
Continuous plug-in bridge , 500 m long, can be cut to length, for potential distribution, $I_{max} = 32 A$, blue	FBST 500-PLC BU	2966692	20
Signal bridge , plug-in, for bridging group indication when there is a free slot on the TMCP SOCKET M base, $I_{max} = 1 A$	TCMP SB	0916602	6

3 Technical data

Operating data	
Nominal voltage	24 V DC
DC supply voltage	18 V DC ... 32 V DC
Nominal current I_N	Depending on the selected item version: 1 A, 2 A, 3 A, 4 A, 6 A, 8 A, 10 A, 12 A
Closed circuit current I_0	In the ON state: 20 mA ... 30 mA, typical (depending on the signal output)
Tripping current (bimetal)	0.3 A, typical (only in the event of an error, until electrically shut down)
Indication of the operating state	<ul style="list-style-type: none"> - Multi-color LED - Status output SF - On/off position of switch S1
Multi-color LED	<p>Green = Device switched on (S1 = ON) or load circuit/Power MOSFET controlled</p> <p>Orange = Overload or short circuit until electronically shut down</p> <p>Red = Device electronically shut down, load circuit/Power MOSFET switched off, undervoltage ($U_B < 8$ V) or after switch-on until the end of the switch-on delay time</p> <p>OFF: Manually switched off (S1 = OFF) or device power supply disconnected</p>
Protection against polarity reversal of U_B	Internal bimetal (failsafe element) triggered, pushbutton moves to OFF position
Auxiliary contacts	Pin 11 (GND) Pin 12 (individual indication) Pin 13/14 (group query)
Switching capacity I_{CN}	Active current limitation of 180%
Load circuit	
Load output	Power MOSFET output (positive switching)
Overload shutdown	$1.1 \times I_N$ (1.05 ... $1.35 \times I_N$), typical
Short circuit current I_K	Active current limitation; $1.8 \times I_N$, maximum (see "Time-current characteristic" on page 6)
Shutdown time	3 s at $I_L > 1.1 \times I_N$, typical 100 ms ... 3 s at $I_L > 1.8 \times I_N$ (or $1.5 \times I_N / 1.3 \times I_N$), typical See "Voltage drop, current limitation, maximum load current" on page 4
R_i when plugged in	≈ 50 m Ω
Temperature shutdown	Internal temperature monitoring with electronic shutdown
Undervoltage monitoring of load output	With hysteresis, no reset required: OFF at $U_B < 8$ V
Switch-on delay t_{Start}	0.5 s, typical after each switch-on and after applying U_B
Load circuit shutdown	Electronic shutdown after overload/short circuit
Free running circuit	External free-wheeling diode recommended on inductive load
Parallel connection of multiple load outputs	Not permitted
Status output	
Electrical data	Positive switching signal output, switches U_B on pin 12 of TCMP SOCKET M base, nominal data: 24 V DC/0.2 A, maximum (short-circuit-proof) The status output is internally terminated to ground using a 10 kOhm resistor.
Status OUT	ECP-E... (signal status OUT), at $U_B = +24$ V +24 V = S1 is ON, load output switched through 0 V = S1 is ON, load output disabled and/or switch S1 is OFF LED lights up red
OFF state	0 V level always present at status output if: <ul style="list-style-type: none"> - Switch S1 is set to ON, but device is still in the switch-on delay phase - Switch S1 is set to OFF or control signal is OFF, device is switched off - Operating voltage U_B is not present

Reset input

Electrical data

Maximum voltage +32 V DC
 High > 8 V DC ≤ 32 V DC
 Low ≤ 3 V DC > 0 V DC
 Current consumption 2.6 mA, typical (+24 V DC)
 Minimum pulse length 10 ms

Reset signal RE (pin 12 of base)



WARNING: Always fill empty slots with the signal bridge.

With the falling edge of a +24 V DC pulse, the electronically disabled ECP-E... can be switched on again remotely via an external button.

This reset signal is supplied in pin 12 of the base and is internally prewired.

On the ECP-E..., the reset simultaneously affects all disabled channels of the current distributor. Activated channels remain unaffected.

General data

Width x length x height

12.5 mm x 60 mm x 70 mm

Weight

40 g

Service life at 1 x I_N

10,000

Ambient temperature

0°C ... +50°C (no condensation, see EN 60204-1)

Storage temperature

-20°C ... +70°C

Insulation material

PA-F

Inflammability class according to UL 94

V0

Backup fuse

Not required, since a redundant failsafe element is integrated. If the failsafe element has been triggered, the pushbutton is in the OFF position.

Housing fixing

Can be plugged into TMCP SOCKET M modular base

Slip-on connections

6.3 mm according to DIN 46244-A6.3-0.8

Humid heat

96 h/95% relative humidity/40°C according to IEC 60068-2-78, Test Cab climatic class 3K3 according to EN 60721

Degree of protection

Housing: IP30, DIN 40050
 Terminal blocks: IP00, DIN 40050

Tests/approvals

Conformance with EMC Directive 2004/108/EC

Noise emission: EN 61000-6-3
 Noise immunity: EN 61000-6-2

Isolation coordination (IEC 60934)

0.5 kV/pollution degree 2, increased isolation in the actuation area

Dielectric strength

32 V DC, maximum (load circuit)

Insulation resistance (OFF state)

None, electronic shutdown only

Vibration resistance

3g, test according to IEC 60068-2-6 Test Fc

Approvals



UL 2367, File E317172 Solid State Overcurrent Protectors
 CE

Voltage drop, current limitation, maximum load current

Nominal current I _N	Typical voltage drop U _{ON} at I _N	Active current limitation (typical)	Maximum load current at 100% operating factor, T _A = 40°C	Maximum load current at 100% operating factor, T _A = 50°C
1 A	80 mV	1.8 x I _N	1 A	1 A
2 A	130 mV	1.8 x I _N	2 A	2 A
3 A	80 mV	1.8 x I _N	3 A	3 A
4 A	100 mV	1.8 x I _N	4 A	4 A
6 A	130 mV	1.8 x I _N	6 A	5 A
8 A	120 mV	1.5 x I _N	8 A	7 A
10 A	150 mV	1.5 x I _N	10 A	9 A
12 A	180 mV	1.3 x I _N	12 A	10.8 A



When mounted in rows without convection cooling, due to the thermal effect during continuous operation (100% operating factor) the nominal device current must only be led to a maximum of 80%.

3.1 Connection diagram



The signal contacts are shown in the OFF or error state.

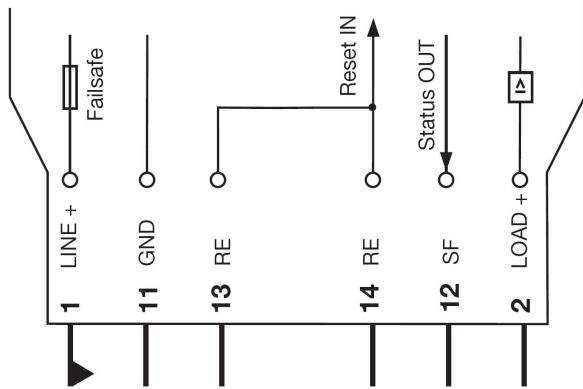

With reset input RE (+24 V DC), with status output SF (+24 V = Load output ON)
 Normal state: SF +24 V = OK
 Error state: SF 0 V

3.3 Dimensions

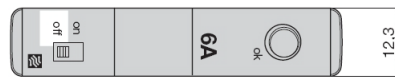
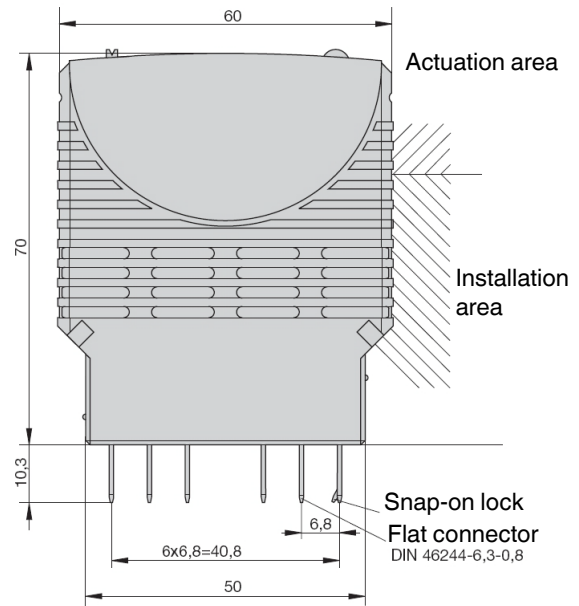

Figure 2 Dimensions (in mm)

3.2 Block diagram (example ECP-E ...)

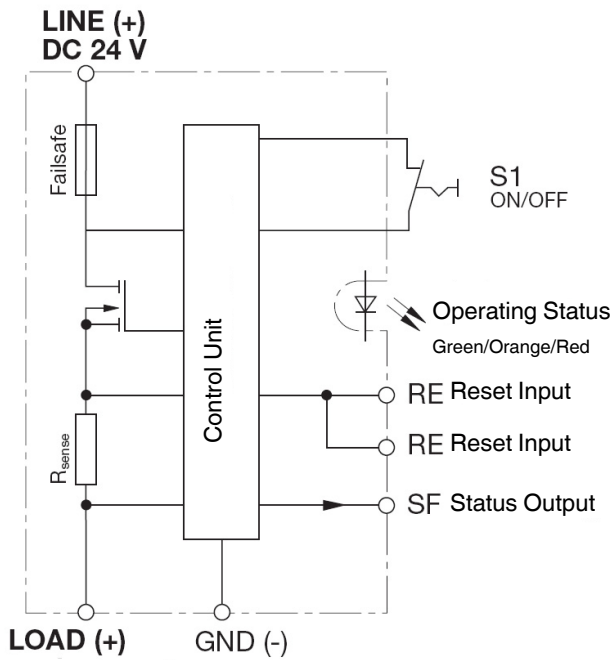

Figure 1 Block diagram (example ECP-E ...)

3.4 Time-current characteristic ($T_A = 25^\circ\text{C}$)

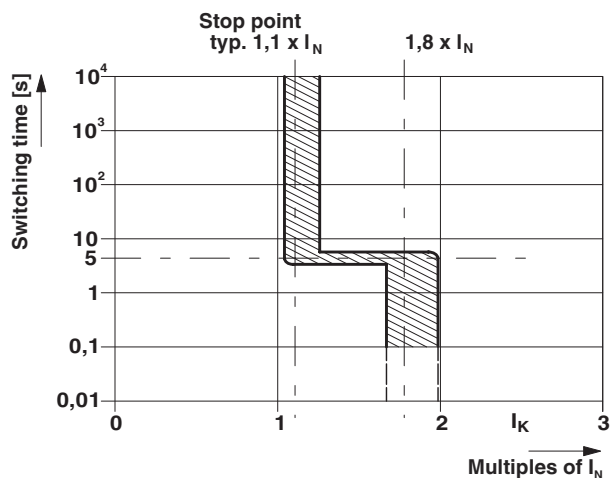

Figure 3 Time-current characteristic

- In the $1.1 \dots 1.8 \times I_N^*$ range, the typical shutdown time is 3 s.
 - The electronic current limitation is typically activated from $1.8 \times I_N^*$.
This means that under all overload conditions (regardless of the current supply and load circuit resistance), 1.8 times the nominal current* typically flows until shutdown. The shutdown time ranges from 100 ms to 3 s depending on the multiple of the nominal current or in the event of short circuit (I_K).
 - Without the current limitation typically activated at $1.8 \times I_N^*$, a significantly higher overcurrent would flow in the event of an overload or short circuit.
- * Typical current limitation $1.8 \times I_N$ at $I_N = 1 \text{ A} \dots 6 \text{ A}$
 Typical current limitation $1.5 \times I_N$ at $I_N = 8 \text{ A}$ or 10 A
 Typical current limitation $1.3 \times I_N$ at $I_N = 12 \text{ A}$

3.5 Safe shutdown

Safe shutdown of the ECP-E... for various supply line lengths and cable cross-sections								
Specific electrical resistance of electrolytic copper $\rho_0 = 0.0178 (\Omega \times \text{mm}^2)/\text{m}$								
$U_B = 19.2 \text{ V DC}$ (80% of 24 V DC)			The voltage drop at the ECP-E... and the tolerance of the shutdown point (typically $1.1 \times I_N = 1.05 \dots 1.35 \times I_N$) have already been taken into consideration.					
ECP-E... nominal current setting I_N (in A) →			3 A		6 A		→ ECP-E... shuts down after typically 3 s ... 5 s	
E.g., Shutdown current $I_{\text{off}} = 1.25 \text{ A} \times I_N$ (in A) →			3.75 A		7.5 A			
R_{max} in Ohm = $(U_B/I_{\text{off}}) - 0.050 \Omega^1$ →			5.07 Ω		2.51 Ω			
ECP-E... safely trips from 0 Ω up to maximum circuit resistance R_{max}								
Cable cross-section A in mm^2 →		0.14 mm^2	0.25 mm^2	0.34 mm^2	0.5 mm^2	0.75 mm^2	1 mm^2	1.5 mm^2
Distance L in meters (= single length) ↓		Total cable resistance in Ohm = $(R_0 \times 2 \times L)/A$						
		↓	↓	↓	↓	↓	↓	↓
5 m		1.27 Ω	0.71 Ω	0.52 Ω	0.36 Ω	0.24 Ω	0.18 Ω	0.12 Ω
10 m		2.54 Ω	1.42 Ω	1.05 Ω	0.71 Ω	0.47 Ω	0.36 Ω	0.24 Ω
15 m		3.81 Ω	2.14 Ω	1.57 Ω	1.07 Ω	0.71 Ω	0.53 Ω	0.36 Ω
20 m		5.09 Ω	2.85 Ω	2.09 Ω	1.42 Ω	0.95 Ω	0.71 Ω	0.47 Ω
25 m		6.36 Ω	3.56 Ω	2.62 Ω	1.78 Ω	1.19 Ω	0.89 Ω	0.59 Ω
30 m		7.63 Ω	4.27 Ω	3.14 Ω	2.14 Ω	1.42 Ω	1.07 Ω	0.71 Ω
35 m		8.90 Ω	4.98 Ω	3.66 Ω	2.49 Ω	1.66 Ω	1.25 Ω	0.83 Ω
40 m		10.17 Ω	5.70 Ω	4.19 Ω	2.85 Ω	1.90 Ω	1.42 Ω	0.95 Ω
45 m		11.44 Ω	6.41 Ω	4.71 Ω	3.20 Ω	2.14 Ω	1.60 Ω	1.07 Ω
50 m		12.71 Ω	7.12 Ω	5.24 Ω	3.56 Ω	2.37 Ω	1.78 Ω	1.19 Ω
75 m		19.07 Ω	10.68 Ω	7.85 Ω	5.34 Ω	3.56 Ω	2.67 Ω	1.78 Ω
100 m		25.34 Ω	14.24 Ω	10.47 Ω	7.12 Ω	4.75 Ω	3.56 Ω	2.37 Ω
125 m		31.79 Ω	17.80 Ω	13.09 Ω	8.90 Ω	5.93 Ω	4.45 Ω	2.97 Ω
150 m		38.14 Ω	21.36 Ω	15.71 Ω	10.68 Ω	7.12 Ω	5.34 Ω	3.56 Ω
175 m		44.50 Ω	24.92 Ω	18.32 Ω	12.46 Ω	8.31 Ω	6.23 Ω	4.15 Ω
200 m		50.86 Ω	28.48 Ω	20.94 Ω	14.24 Ω	9.49 Ω	7.12 Ω	4.75 Ω
225 m		57.21 Ω	32.04 Ω	23.56 Ω	16.02 Ω	10.68 Ω	8.01 Ω	5.34 Ω
250 m		63.57 Ω	35.60 Ω	26.18 Ω	17.80 Ω	11.87 Ω	8.90 Ω	5.93 Ω
Example 1: Maximum permissible distance for 1.5 mm^2 and 3 A → Approximately 200 m²								
Example 2: Maximum permissible distance for 1.5 mm^2 and 6 A → Approximately 100 m								
Example 3: Mixed wiring: (Control cabinet --- sensor/actuator level)								
					R1 = 40 m in 1.5 mm^2 and R2 = 5 m in 0.25 mm^2			
					R1 = 0.95 Ohm, R2 = 0.71 Ohm			
					Total (R1 + R2) = 1.66 Ohm			

¹ Internal resistance of miniature circuit breakers

² Shutdown current $I_{\text{off}} = 3 \text{ A} \times 1.25 \text{ A} = 3.75 \text{ A}$
 Maximum circuit resistance $R_{\text{max}} = U_B/I_{\text{off}} - 0.050 \Omega$ (internal resistance of miniature circuit breakers)
 $R_{\text{max}} = (19.2 \text{ V}/3.75 \text{ A}) - 0.050 \Omega = 5.07 \Omega$
 In the table, the calculated value of 5.07 Ω lies between 200 m and 225 m (4.75 Ω and 5.34 Ω).
 Therefore a distance of around 200 m can be covered.

4.3 Assembly

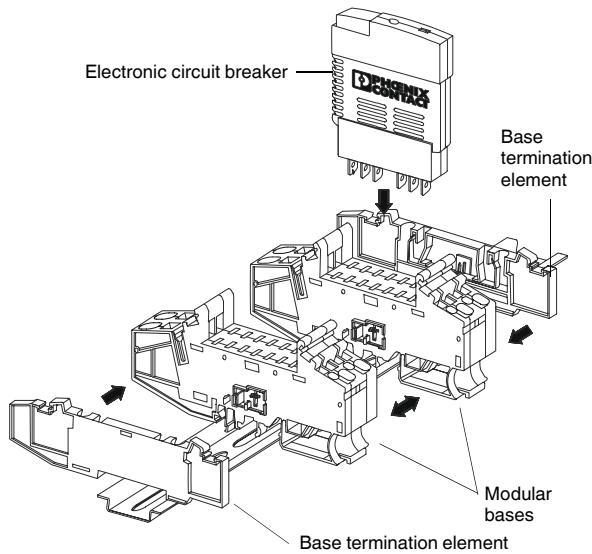

Figure 5 Assembly



WARNING: Always fill empty slots with the TMCP SB signal bridge.

To assemble, proceed as follows:

- Snap TMCP SOCKET M base onto an NS 35 DIN rail according to EN 60751.
- Push bases together.
- Snap on TMCP CONNECT LR base termination elements to the left and right-hand side.
- Cut FBST 500... power rail to length as required and insert in bases.
- Insert connecting cables in the spring-cage terminal blocks (see "Connecting spring-cage terminal blocks" on page 9 and "Pin assignment on base" on page 9).
- Insert ECP-E...
- If necessary, secure the ECP-E... and base using a clamp (see "Locking the base and ECP-E..." on page 10).

4.4 Connecting spring-cage terminal blocks

Spring-cage terminal blocks for solid wires and stranded cables with and without ferrules.

Use the specified screwdriver size (SD) to release the spring cage.

Connection	Spring-cage terminal blocks for	Screwdriver size (SD)
LINE supply (1)	1.5 ... 10 mm ²	SD 2 (0.8 x 4.0 mm)
LOAD output (2)	0.25 ... 4 mm ²	SD 1 (0.6 x 3.5 mm)
Reference potential GND or group indication connections (11 or 13, 14)	0.25 ... 2.5 mm ²	SD 1 (0.6 x 3.5 mm)
Individual indication connection (12)	0.25 ... 1.5 mm ²	SD 0 (0.4 x 2.5 mm)

4.5 Pin assignment on base

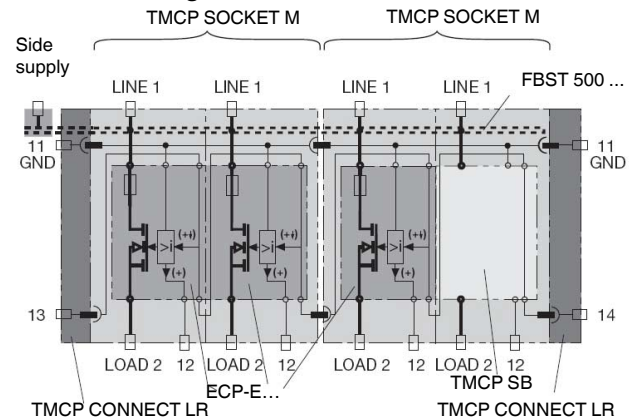

Figure 6 Connection diagram

PIN Assignment

11	GND	
12	Status message SF	+24 V = OK
13, 14	Reset input RE (group reset)	+24 V falling edge



WARNING: Always fill empty slots with the TMCP SB signal bridge.

[2(k)]	LINE (+)
[12]	GND
[24]	Reset IN+, +24 V
[2(i)]	Not used
[23]	Reset IN+, +24 V
[11]	Status OUT, +24 V = OK
[1]	LOAD (+)

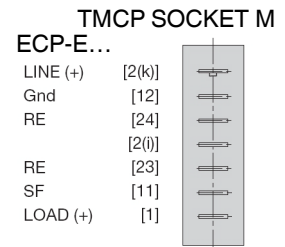

Figure 7 Pin assignment

4.6 Locking the base and ECP-E...

If mounted overhead, the ECP-E... must be connected to the base using the ECP-LOCK clamp.

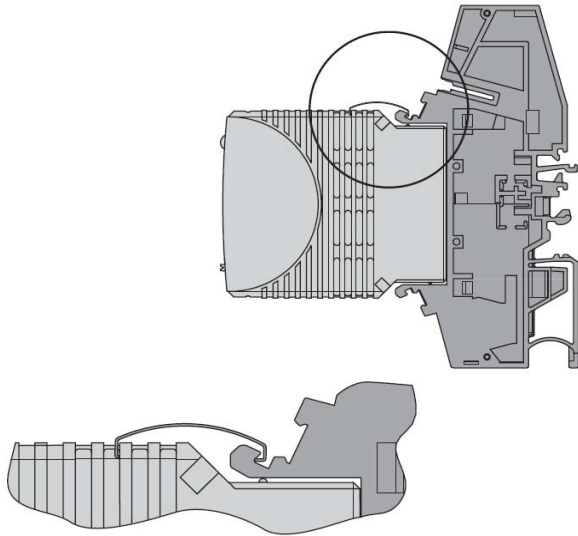

Figure 8 Mounting the ECP-LOCK

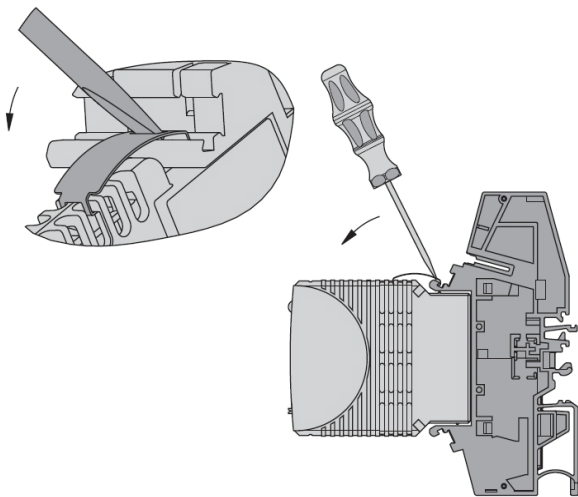

Figure 9 Removing the ECP-LOCK

Компания «Life Electronics» занимается поставками электронных компонентов импортного и отечественного производства от производителей и со складов крупных дистрибьюторов Европы, Америки и Азии.

С конца 2013 года компания активно расширяет линейку поставок компонентов по направлению коаксиальный кабель, кварцевые генераторы и конденсаторы (керамические, пленочные, электролитические), за счёт заключения дистрибьюторских договоров

Мы предлагаем:

- Конкурентоспособные цены и скидки постоянным клиентам.
- Специальные условия для постоянных клиентов.
- Подбор аналогов.
- Поставку компонентов в любых объемах, удовлетворяющих вашим потребностям.
- Приемлемые сроки поставки, возможна ускоренная поставка.
- Доставку товара в любую точку России и стран СНГ.
- Комплексную поставку.
- Работу по проектам и поставку образцов.
- Формирование склада под заказчика.
- Сертификаты соответствия на поставляемую продукцию (по желанию клиента).
- Тестирование поставляемой продукции.
- Поставку компонентов, требующих военную и космическую приемку.
- Входной контроль качества.
- Наличие сертификата ISO.

В составе нашей компании организован Конструкторский отдел, призванный помогать разработчикам, и инженерам.

Конструкторский отдел помогает осуществить:

- Регистрацию проекта у производителя компонентов.
- Техническую поддержку проекта.
- Защиту от снятия компонента с производства.
- Оценку стоимости проекта по компонентам.
- Изготовление тестовой платы монтаж и пусконаладочные работы.



Тел: +7 (812) 336 43 04 (многоканальный)

Email: org@lifeelectronics.ru