



**MICROCHIP**

---

**MGC3130**  
**Hillstar Development Kit**  
**User's Guide**

---

**Note the following details of the code protection feature on Microchip devices:**

- Microchip products meet the specification contained in their particular Microchip Data Sheet.
- Microchip believes that its family of products is one of the most secure families of its kind on the market today, when used in the intended manner and under normal conditions.
- There are dishonest and possibly illegal methods used to breach the code protection feature. All of these methods, to our knowledge, require using the Microchip products in a manner outside the operating specifications contained in Microchip's Data Sheets. Most likely, the person doing so is engaged in theft of intellectual property.
- Microchip is willing to work with the customer who is concerned about the integrity of their code.
- Neither Microchip nor any other semiconductor manufacturer can guarantee the security of their code. Code protection does not mean that we are guaranteeing the product as "unbreakable."

Code protection is constantly evolving. We at Microchip are committed to continuously improving the code protection features of our products. Attempts to break Microchip's code protection feature may be a violation of the Digital Millennium Copyright Act. If such acts allow unauthorized access to your software or other copyrighted work, you may have a right to sue for relief under that Act.

---

Information contained in this publication regarding device applications and the like is provided only for your convenience and may be superseded by updates. It is your responsibility to ensure that your application meets with your specifications. MICROCHIP MAKES NO REPRESENTATIONS OR WARRANTIES OF ANY KIND WHETHER EXPRESS OR IMPLIED, WRITTEN OR ORAL, STATUTORY OR OTHERWISE, RELATED TO THE INFORMATION, INCLUDING BUT NOT LIMITED TO ITS CONDITION, QUALITY, PERFORMANCE, MERCHANTABILITY OR FITNESS FOR PURPOSE. Microchip disclaims all liability arising from this information and its use. Use of Microchip devices in life support and/or safety applications is entirely at the buyer's risk, and the buyer agrees to defend, indemnify and hold harmless Microchip from any and all damages, claims, suits, or expenses resulting from such use. No licenses are conveyed, implicitly or otherwise, under any Microchip intellectual property rights.

**Trademarks**

The Microchip name and logo, the Microchip logo, dsPIC, FlashFlex, KEELOQ, KEELOQ logo, MPLAB, PIC, PICmicro, PICSTART, PIC<sup>32</sup> logo, rPIC, SST, SST Logo, SuperFlash and UNI/O are registered trademarks of Microchip Technology Incorporated in the U.S.A. and other countries.

FilterLab, Hampshire, HI-TECH C, Linear Active Thermistor, MTP, SEEVAL and The Embedded Control Solutions Company are registered trademarks of Microchip Technology Incorporated in the U.S.A.

Silicon Storage Technology is a registered trademark of Microchip Technology Inc. in other countries.


Analog-for-the-Digital Age, Application Maestro, BodyCom, chipKIT, chipKIT logo, CodeGuard, dsPICDEM, dsPICDEM.net, dsPICworks, dsSPEAK, ECAN, ECONOMONITOR, FanSense, HI-TIDE, In-Circuit Serial Programming, ICSP, Mindi, MiWi, MPASM, MPF, MPLAB Certified logo, MPLIB, MPLINK, mTouch, Omniscent Code Generation, PICC, PICC-18, PICDEM, PICDEM.net, PICkit, PICtail, REAL ICE, rLAB, Select Mode, SQI, Serial Quad I/O, Total Endurance, TSHARC, UniWinDriver, WiperLock, ZENA and Z-Scale are trademarks of Microchip Technology Incorporated in the U.S.A. and other countries.

SQTP is a service mark of Microchip Technology Incorporated in the U.S.A.

GestIC and ULPP are registered trademarks of Microchip Technology Germany II GmbH & Co. KG, a subsidiary of Microchip Technology Inc., in other countries.

All other trademarks mentioned herein are property of their respective companies.

© 2013, Microchip Technology Incorporated, Printed in the U.S.A., All Rights Reserved.

 Printed on recycled paper.

ISBN: 9781620775134

**QUALITY MANAGEMENT SYSTEM**  
**CERTIFIED BY DNV**  
**== ISO/TS 16949 ==**

*Microchip received ISO/TS-16949:2009 certification for its worldwide headquarters, design and wafer fabrication facilities in Chandler and Tempe, Arizona; Gresham, Oregon and design centers in California and India. The Company's quality system processes and procedures are for its PIC<sup>®</sup> MCUs and dsPIC<sup>®</sup> DSCs, KEELOQ<sup>®</sup> code hopping devices, Serial EEPROMs, microperipherals, nonvolatile memory and analog products. In addition, Microchip's quality system for the design and manufacture of development systems is ISO 9001:2000 certified.*

**Object of Declaration: MGC3130 Hillstar Development Kit User's Guide**

EU Declaration of Conformity

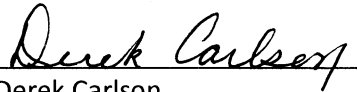
This declaration of conformity is issued by the manufacturer.

The development/evaluation tool is designed to be used for research and development in a laboratory environment. This development/evaluation tool is not a Finished Appliance, nor is it intended for incorporation into Finished Appliances that are made commercially available as single functional units to end users under EU EMC Directive 2004/108/EC and as supported by the European Commission's Guide for the EMC Directive 2004/108/EC (8<sup>th</sup> February 2010).

This development/evaluation tool complies with EU RoHS2 Directive 2011/65/EU.

For information regarding the exclusive, limited warranties applicable to Microchip products, please see Microchip's standard terms and conditions of sale, which are printed on our sales documentation and available at [www.microchip.com](http://www.microchip.com).

Signed for and on behalf of Microchip Technology Inc. at Chandler, Arizona, USA

  
Derek Carlson

VP Development Tools

16-July-2013  
Date

# MGC3130 Hillstar Development Kit User's Guide

---

NOTES:

**Table of Contents**

<b>Preface</b> .....	<b>7</b>
Introduction.....	7
Document Layout .....	7
Conventions Used in this Guide .....	8
Warranty Registration.....	9
Recommended Reading.....	9
The Microchip Web Site .....	10
Development Systems Customer Change Notification Service .....	10
Customer Support .....	11
Revision History .....	11
 <b>Chapter 1. Overview</b>	
1.1 Introduction .....	13
1.2 Hillstar Concept and Deliverables .....	13
1.3 Hillstar Development Kit Package Content .....	14
1.4 Hillstar Development Kit Reference Electrodes .....	15
1.5 MGC3130 Software Package – Aurea GUI and GestIC Library .....	17
1.6 MGC3130 Software Development Kit (SDK) .....	17
 <b>Chapter 2. Getting Started</b>	
2.1 Prerequisites .....	19
2.2 Step 1: Build-up Development Kit .....	19
2.3 Step 2: Connecting Hillstar Development Kit with Your PC .....	20
2.4 Step 3: Install Windows CDC Driver .....	20
2.5 Step 4: Start Aurea .....	20
 <b>Chapter 3. Hillstar Boards – Hardware Description</b>	
3.1 Overview .....	23
3.1.1 I <sup>2</sup> C™ to USB Bridge .....	23
3.1.2 MGC3130 Unit .....	23
3.1.3 95x60 mm Reference Electrode PCB .....	23
3.2 MGC3130 Unit .....	24
3.3 Hillstar 95x60 mm Reference Electrode .....	25
3.4 I <sup>2</sup> C to USB Bridge .....	27
 <b>Chapter 4. Design In: Hillstar In Target Application</b>	
4.1 Introduction .....	29
4.2 Integration Examples .....	29
 <b>Chapter 5. Troubleshooting</b>	

# MGC3130 Hillstar Development Kit User's Guide

---

## Appendix A. Schematics

A.1 Introduction .....	35
A.2 Bill of Materials .....	35
A.3 Board – Schematics and Layout .....	37

## Appendix B. Sensitivity Profile and Capacitances

B.1 Introduction .....	41
B.2 Sensitivity Profiles .....	41
B.3 Electrode Capacities .....	42

## Appendix C. Parameterization Support

C.1 How to Build a Hand Brick .....	43
C.2 Usage of the Hand Brick as Artificial Hand .....	45

## Appendix D. Driver Installation Manual

D.1 Open Device Manager .....	47
D.2 Select Device .....	47
D.3 Locate Driver .....	48
D.4 Verify Communication .....	48

## Appendix E. Glossary

<b>Worldwide Sales and Service .....</b>	<b>50</b>
--	-----------



# MGC3130 HILLSTAR DEVELOPMENT KIT USER'S GUIDE

---

---

## Preface

---

---

### NOTICE TO CUSTOMERS

All documentation becomes dated, and this manual is no exception. Microchip tools and documentation are constantly evolving to meet customer needs, so some actual dialogs and/or tool descriptions may differ from those in this document. Please refer to our web site ([www.microchip.com](http://www.microchip.com)) to obtain the latest documentation available.

Documents are identified with a "DS" number. This number is located on the bottom of each page, in front of the page number. The numbering convention for the DS number is "DSXXXXA", where "XXXX" is the document number and "A" is the revision level of the document.

For the most up-to-date information on development tools, see the MPLAB® IDE online help. Select the Help menu, and then Topics to open a list of available online help files.

## INTRODUCTION

This chapter contains general information that will be useful to know before using the Hillstar Development Kit. Items discussed in this chapter include:

- Document Layout
- Conventions Used in this Guide
- Warranty Registration
- Recommended Reading
- The Microchip Web Site
- Development Systems Customer Change Notification Service
- Customer Support
- Revision History

## DOCUMENT LAYOUT

This document describes the installation and use of the MGC3130 Hillstar Development Kit. The document is organized as follows:

- **Chapter 1. "Overview"**
- **Chapter 2. "Getting Started"**
- **Chapter 3. "Hillstar Boards – Hardware Description"**
- **Chapter 4. "Design In: Hillstar In Target Application"**
- **Chapter 5. "Troubleshooting"**
- **Appendix A. "Schematics"**
- **Appendix B. "Sensitivity Profile and Capacitances"**
- **Appendix C. "Parameterization Support"**
- **Appendix D. "Driver Installation Manual"**
- **Appendix E. "Glossary"**

# MGC3130 Hillstar Development Kit User's Guide

---

## CONVENTIONS USED IN THIS GUIDE

This manual uses the following documentation conventions:

### DOCUMENTATION CONVENTIONS

Description	Represents	Examples
<b>Arial font:</b>		
Italic characters	Referenced books	<i>MPLAB<sup>®</sup> IDE User's Guide</i>
	Emphasized text	...is the <i>only</i> compiler...
Initial caps	A window	the Output window
	A dialog	the Settings dialog
	A menu selection	select Enable Programmer
Quotes	A field name in a window or dialog	"Save project before build"
Underlined, italic text with right angle bracket	A menu path	<u><i>File&gt;Save</i></u>
Bold characters	A dialog button	Click <b>OK</b>
	A tab	Click the <b>Power</b> tab
N'Rnnnn	A number in verilog format, where N is the total number of digits, R is the radix and n is a digit.	4'b0010, 2'hF1
Text in angle brackets < >	A key on the keyboard	Press <Enter>, <F1>
<b>Courier New font:</b>		
Plain Courier New	Sample source code	#define START
	Filenames	autoexec.bat
	File paths	c:\mcc18\h
	Keywords	_asm, _endasm, static
	Command-line options	-Opa+, -Opa-
	Bit values	0, 1
	Constants	0xFF, 'A'
Italic Courier New	A variable argument	<i>file.o</i> , where <i>file</i> can be any valid filename
Square brackets [ ]	Optional arguments	mcc18 [options] <i>file</i> [options]
Curly brackets and pipe character: {   }	Choice of mutually exclusive arguments; an OR selection	errorlevel {0 1}
Ellipses...	Replaces repeated text	var_name [, var_name...]
	Represents code supplied by user	void main (void) { ... }



## WARRANTY REGISTRATION

Please complete the enclosed Warranty Registration Card and mail it promptly. Sending in the Warranty Registration Card entitles users to receive new product updates. Interim software releases are available at the Microchip web site.

## RECOMMENDED READING

This user's guide describes how to use the Hillstar Development Kit. Other useful documents are listed below. The following Microchip documents are available and recommended as supplemental reference resources.

- “*MGC3130 GestIC<sup>®</sup> Design Guide: Electrodes and System Design*” (DS40001716). This document describes the MGC3130 system characteristic parameters and the design process. It enables the user to generate a good electrode design and to parameterize the full GestIC system.
- “*MGC3130 GestIC<sup>®</sup> Library Interface Description User’s Guide*” (DS40001718). This document is the interface description of the MGC3130’s GestIC Library. It outlines the function of the Library’s message interface, and contains the complete message reference to control and operate the MGC3130 system.
- “*MGC3130 Single-Zone 3D Gesture Controller Data Sheet*” (DS40001667). Consult this document for information regarding the MGC3130 3D Tracking and Gesture Controller.
- “*MGC3130 Aurea Graphical User Interface User’s Guide*” (DS40001681). This document describes how to use the MGC3130 Aurea Graphical User Interface.

# MGC3130 Hillstar Development Kit User's Guide

---

## THE MICROCHIP WEB SITE

Microchip provides online support via our web site at [www.microchip.com](http://www.microchip.com). This web site is used as a means to make files and information easily available to customers. Accessible by using your favorite Internet browser, the web site contains the following information:

- **Product Support** – Data sheets and errata, application notes and sample programs, design resources, user's guides and hardware support documents, latest software releases and archived software
- **General Technical Support** – Frequently Asked Questions (FAQs), technical support requests, online discussion groups, Microchip consultant program member listing
- **Business of Microchip** – Product selector and ordering guides, latest Microchip press releases, listing of seminars and events, listings of Microchip sales offices, distributors and factory representatives

## DEVELOPMENT SYSTEMS CUSTOMER CHANGE NOTIFICATION SERVICE

Microchip's customer notification service helps keep customers current on Microchip products. Subscribers will receive e-mail notification whenever there are changes, updates, revisions or errata related to a specified product family or development tool of interest.

To register, access the Microchip web site at [www.microchip.com](http://www.microchip.com), click on Customer Change Notification and follow the registration instructions.

The Development Systems product group categories are:

- **Compilers** – The latest information on Microchip C compilers, assemblers, linkers and other language tools. These include all MPLAB<sup>®</sup> C compilers; all MPLAB assemblers (including MPASM<sup>™</sup> assembler); all MPLAB linkers (including MPLINK<sup>™</sup> object linker); and all MPLAB librarians (including MPLIB<sup>™</sup> object librarian).
- **Emulators** – The latest information on Microchip in-circuit emulators. This includes the MPLAB REAL ICE<sup>™</sup> and MPLAB ICE 2000 in-circuit emulators.
- **In-Circuit Debuggers** – The latest information on the Microchip in-circuit debuggers. This includes MPLAB ICD 3 in-circuit debuggers and PICKit<sup>™</sup> 3 debug express.
- **MPLAB<sup>®</sup> IDE** – The latest information on Microchip MPLAB IDE, the Windows<sup>®</sup> Integrated Development Environment for development systems tools. This list is focused on the MPLAB IDE, MPLAB IDE Project Manager, MPLAB Editor and MPLAB SIM simulator, as well as general editing and debugging features.
- **Programmers** – The latest information on Microchip programmers. These include production programmers such as MPLAB REAL ICE in-circuit emulator, MPLAB ICD 3 in-circuit debugger and MPLAB PM3 device programmers. Also included are nonproduction development programmers such as PICSTART<sup>®</sup> Plus and PICKit 2 and 3.

## CUSTOMER SUPPORT

Users of Microchip products can receive assistance through several channels:

- Distributor or Representative
- Local Sales Office
- Field Application Engineer (FAE)
- Technical Support

Customers should contact their distributor, representative or field application engineer (FAE) for support. Local sales offices are also available to help customers. A listing of sales offices and locations is included in the back of this document.

Technical support is available through the web site at:

<http://www.microchip.com/support>.

## REVISION HISTORY

### **Revision A (October, 2013)**

This is the initial release of this document.

# MGC3130 Hillstar Development Kit User's Guide

---

NOTES:



# MGC3130 HILLSTAR DEVELOPMENT KIT USER'S GUIDE

---

---

## Chapter 1. Overview

---

---

### 1.1 INTRODUCTION

The MGC3130 is the first product based on Microchip's GestIC<sup>®</sup> technology. It is developed as a mixed-signal controller. The MGC3130 has one transmit and five very sensitive receive channels that are capable to detect changes of a transmitted electrical field (E-field) corresponding to capacitive changes in the femtofarad ( $1 \text{ fF} = 10^{-15}\text{F}$ ) range.

In order to transmit and receive an electrical field, electrodes have to be connected to the transmitting and receiving channels of the MGC3130 controller. The spatial arrangement of the electrodes allows the chip to determine the center of gravity of the electric field distortion, and thus position tracking and gesture recognition of a user's hand in the detection space.

### 1.2 HILLSTAR CONCEPT AND DELIVERABLES

The Hillstar Development Kit is designed to support an easy integration of Microchip's MGC3130 3D Tracking and Gesture Controller into customer's applications. It provides MGC3130 system setup, related hardware and software references.

With the MGC3130 Software Package, including Aurea Graphical User Interface and GestIC Library, the MGC3130 Software Development Kit (SDK) and PIC18 Host Reference code, design-in is easy in five steps:

1. Feature Definition
2. Electrode Design
3. MGC3130 Parameterization
4. Host Application Programming
5. Verification

Hillstar hardware builds a complete MGC3130 reference system consisting of three individual PCBs:

- MGC3130 Unit
- I<sup>2</sup>C™ to USB Bridge
- Reference Electrode with a 95x60 mm sensitive area

It can be plugged to a PC via USB cable and used for evaluation of MGC3130 chip and GestIC technology. During the customer's design-in process the individual boards can be combined according to the customers need.

Three examples are given below:

- Combine MGC3130 Unit and I<sup>2</sup>C to USB Bridge to evaluate customized electrodes
- Use I<sup>2</sup>C to USB Bridge to parameterize and debug the MGC3130 application circuitry in the customer's design
- Combine MGC3130 Unit and Electrodes to develop gesture-driven applications for PC based or embedded software environments

# MGC3130 Hillstar Development Kit User's Guide

---

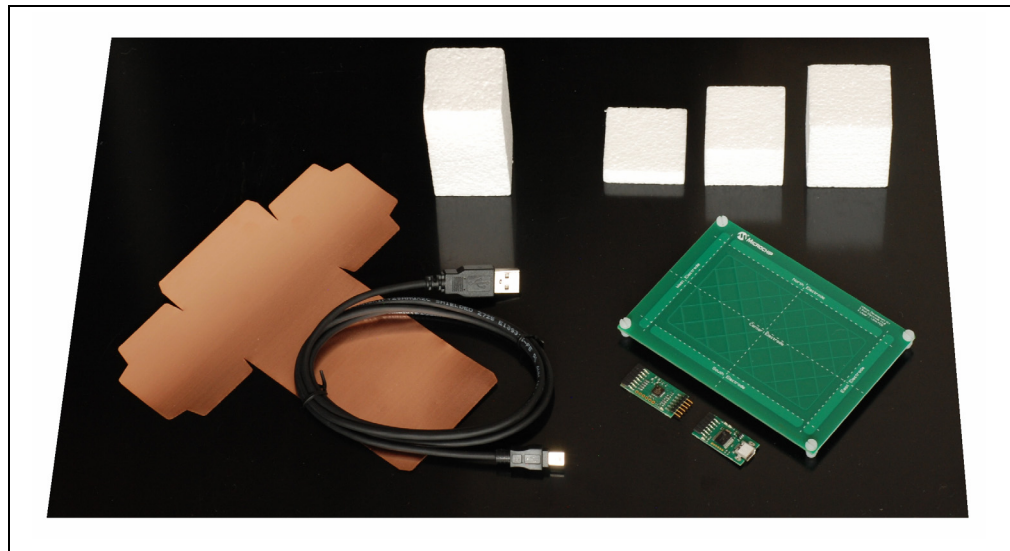
The Hillstar Development Kit provides an artificial test hand, further called hand brick, helping to stimulate the human hand operating the GestIC application. The hand brick has to be used during the design-in process to parametrize and evaluate customer's applications. The hand brick's surface is conductive and connected to GND via cable in order to reproduce the grounding conditions of the human body.

## 1.3 HILLSTAR DEVELOPMENT KIT PACKAGE CONTENT

The Hillstar Development Kit package content is listed below:

- MGC3130 Module
- I<sup>2</sup>C to USB Bridge Module
- 4-layer reference electrode (95x60 mm sensitive area)
- 'Hand brick' set (self-assembly, four foam blocks, one copper foil)
- USB Cable for PC connection

**FIGURE 1-1: HILLSTAR DEVELOPMENT KIT**



The 'hand brick' set is used during the design-in process for sensor calibration and performance evaluation purposes. For usage and assembly information, refer to **Appendix C. "Parameterization Support"**.

## 1.4 HILLSTAR DEVELOPMENT KIT REFERENCE ELECTRODES

The Hillstar development kit includes a collection of layout references (Gerber files) for electrode designs and ready-to-use sensor modules with MGC3130 backside assembly.

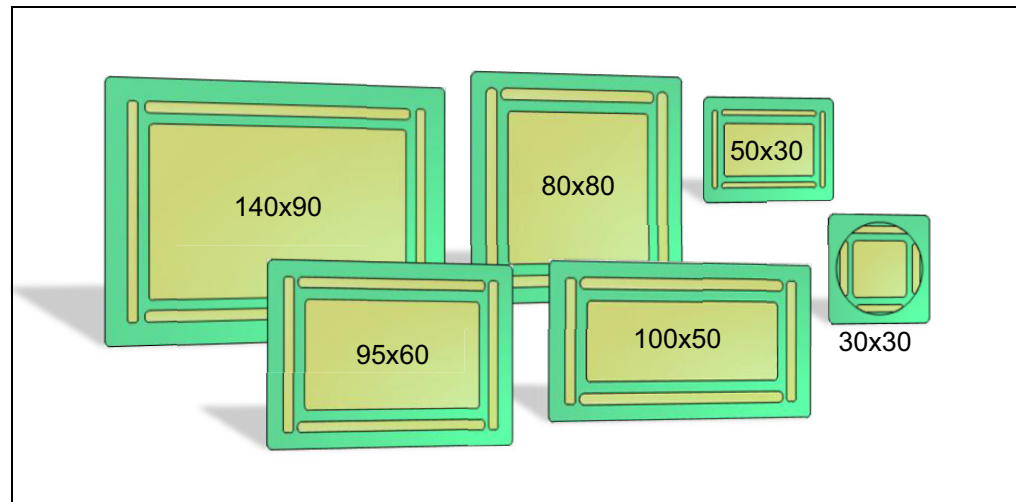
The following electrode designs are included:

- **140x90 mm sensitive area** – outline 168 x 119 mm
- **95x60 mm sensitive area** – outline of 120 x 85 mm
- **80x80 mm sensitive area** – outline 104 x 104 mm
- **100x50 mm sensitive area** – outline 128 x 72 mm
- **50x30 mm sensitive area** – outline 63 x 47 mm
- **30x30 mm sensitive area** – outline 49 x 49 mm

### Sensor Modules

- **95x60 mm sensitive area** – outline of 120 x 85 mm
- **30x30 mm sensitive area** – outline 49 x 52 mm

FIGURE 1-2: HILLSTAR DEVELOPMENT KIT REFERENCE ELECTRODES



Dimensions of the designs are given in Table 1-1 and Figure 1-3 below.

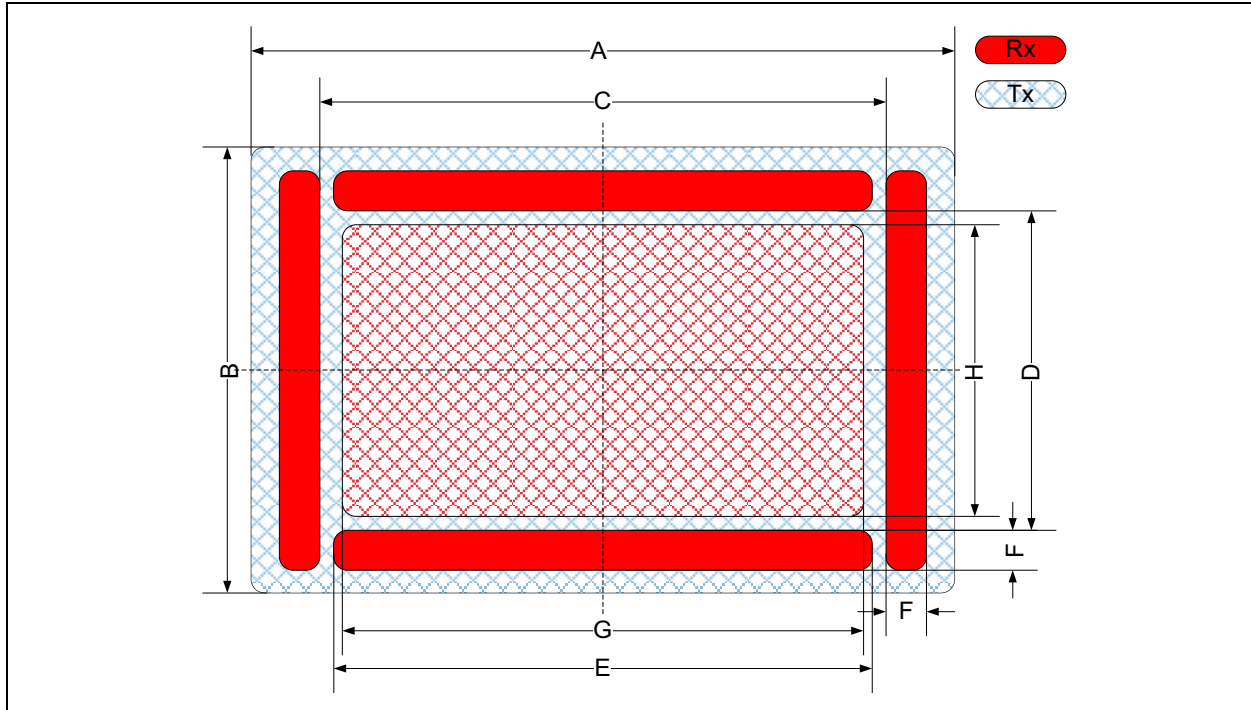
# MGC3130 Hillstar Development Kit User's Guide

**TABLE 1-1: ELECTRODE DIMENSIONS**

Sensitive Area	140x90 mm	95x60 mm <sup>(1)</sup>	80x80 mm	100x50 mm	50x30 mm	30x30 mm <sup>(2)</sup>
<b>Version</b>	1.0	1.0	1.0	1.0	1.0	1.0
<b>Layer</b>	2	2	2	2	2	2
<b>Aspect Ratio</b>	approx. 3:2	approx. 3:2	1:1	approx. 2:1	5:3	1:1
<b>A</b>	168 mm	120 mm	104 mm	128 mm	63 mm	49 mm
<b>B</b>	119 mm	85 mm	104 mm	72 mm	47 mm	49 mm
<b>C</b>	138 mm	95,7 mm	79.8 mm	103,6 mm	50 mm	31.8 mm
<b>D</b>	88,7 mm	60,5 mm	79.8 mm	99,6 mm	46 mm	27,3 mm
<b>E</b>	131,7 mm	91,7 mm	75,8 mm	99,6 mm	46 mm	27,3 mm
<b>F</b>	5 mm	5 mm	5 mm	5 mm	2,5 mm	3,5 mm
<b>G</b>	128 mm	85,7 mm	69,8 mm	93,6 mm	44 mm	25,8 mm
<b>H</b>	78,7 mm	50, 5 mm	69, 8 mm	36, 8 mm	24 mm	25,8 mm
<b>Center Electrode cross-hatching</b>	3%	3%	5%	5%	5%	5%
<b>Tx Electrode cross-hatching</b> -under center electrode -outside center electrode	50 % 20 %	50% 20%	50% 20%	50 % 20 %	50 % 20 %	50 % 20 %
<b>Note 1:</b> These dimensions are also valid for 95x60 mm sensor module.						
<b>Note 2:</b> These dimensions are also valid for 30x30 mm sensor module except the B dimension which is equal to 52 and Tx electrode which is solid instead of cross-hatched.						



**FIGURE 1-3: ELECTRODE DIMENSIONS**



The Gerber data of all electrode reference designs are included in the MGC3130 Hillstar Hardware Reference package and can be downloaded from Microchip's web site [www.microchip.com/GestICGettingStarted](http://www.microchip.com/GestICGettingStarted).

## 1.5 MGC3130 SOFTWARE PACKAGE – AUREA GUI AND GestIC LIBRARY

The MGC3130 Software Package contains all relevant system software and documentation. Hillstar Development Kit is supported by MGC3130 Software Package 0.4 and following versions.

The package contains:

- Aurea PC software
- GestIC Library binary file
- GestIC Parameterization files
- Windows CDC driver
- Documentation

The latest MGC3130 software package can be downloaded from Microchip's web site [www.microchip.com/GestICGettingStarted](http://www.microchip.com/GestICGettingStarted).

## 1.6 MGC3130 SOFTWARE DEVELOPMENT KIT (SDK)

The MGC3130 Software Development Kit (SDK) supports the integration of MGC3130 into a software environment. Thus, it includes a C reference code for GestIC API, a precompiled library for Windows operating systems and a demo application using the GestIC API interface.

Hillstar Development Kit is supported by MGC3130 SDK 0.4 and the following versions.

The latest SDK can be downloaded from Microchip's web site [www.microchip.com/GestICGettingStarted](http://www.microchip.com/GestICGettingStarted).

# MGC3130 Hillstar Development Kit User's Guide

---

NOTES:

---

---

## Chapter 2. Getting Started

---

---

Hillstar Development Kit can be used as a stand-alone GestIC system and evaluated in conjunction with the Aurea PC software. This section describes how to get started.

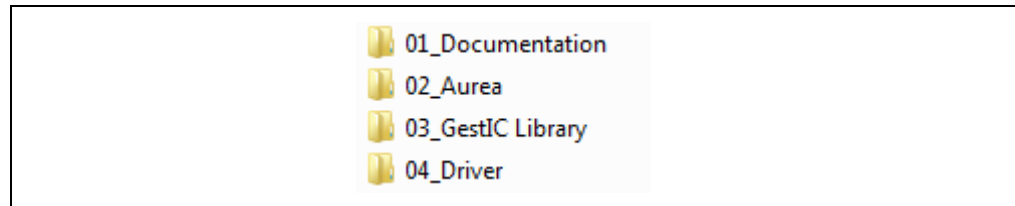
### 2.1 PREREQUISITES

The following prerequisites have to be fulfilled:

- PC with Windows® XP, Windows 7 or Windows 8 operating system and USB port and minimum screen resolution of 1024x768
- Hillstar Development Kit (MGC3130 Unit, I<sup>2</sup>C to USB Bridge, 95x60 mm frame electrode)
- MGC3130 Software Package 0.4 and following versions

The MGC3130 Software Package is available as a .zip file. Unzip the file, run `setup.exe` and install the package to your PC. The folder structure is as shown in Figure 2-1.

**FIGURE 2-1: FOLDER STRUCTURE**



### 2.2 STEP 1: BUILD-UP DEVELOPMENT KIT

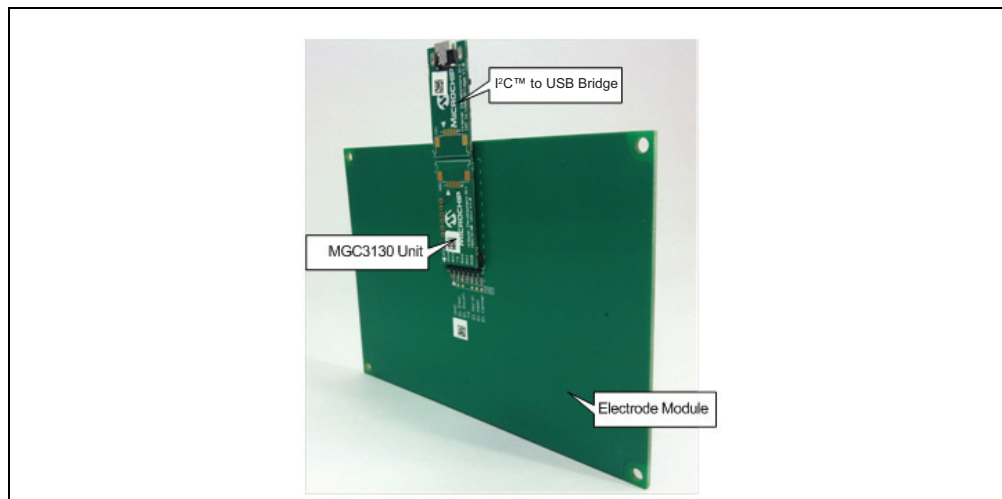
Connect Electrodes, MGC3130 Unit and I<sup>2</sup>C to USB Bridge as shown in Figure 2-2.

**Note:** Make sure the MGC3130 Unit and the I<sup>2</sup>C USB Bridge are already connected before plugging in the USB connection.

# MGC3130 Hillstar Development Kit User's Guide

---

FIGURE 2-2: HILLSTAR DEVELOPMENT KIT ASSEMBLING



## 2.3 STEP 2: CONNECTING HILLSTAR DEVELOPMENT KIT WITH YOUR PC

Use the supplied USB cable to connect the Hillstar Development Kit to your PC. The Power LEDs on both, I<sup>2</sup>C to USB Bridge and MGC3130 Unit will illuminate. Furthermore, LED 1 on the I<sup>2</sup>C to USB Bridge will flash very fast (~10 Hz). In case LED 1 is flashing slow (~1 Hz), the Windows CDC driver is already installed on your PC. Please skip the next step and go to **Section 2.5 “Step 4: Start Aurea”**.

## 2.4 STEP 3: INSTALL WINDOWS CDC DRIVER

The Windows CDC driver can be found in the MGC3130 Software Package in folder `04_Driver`.

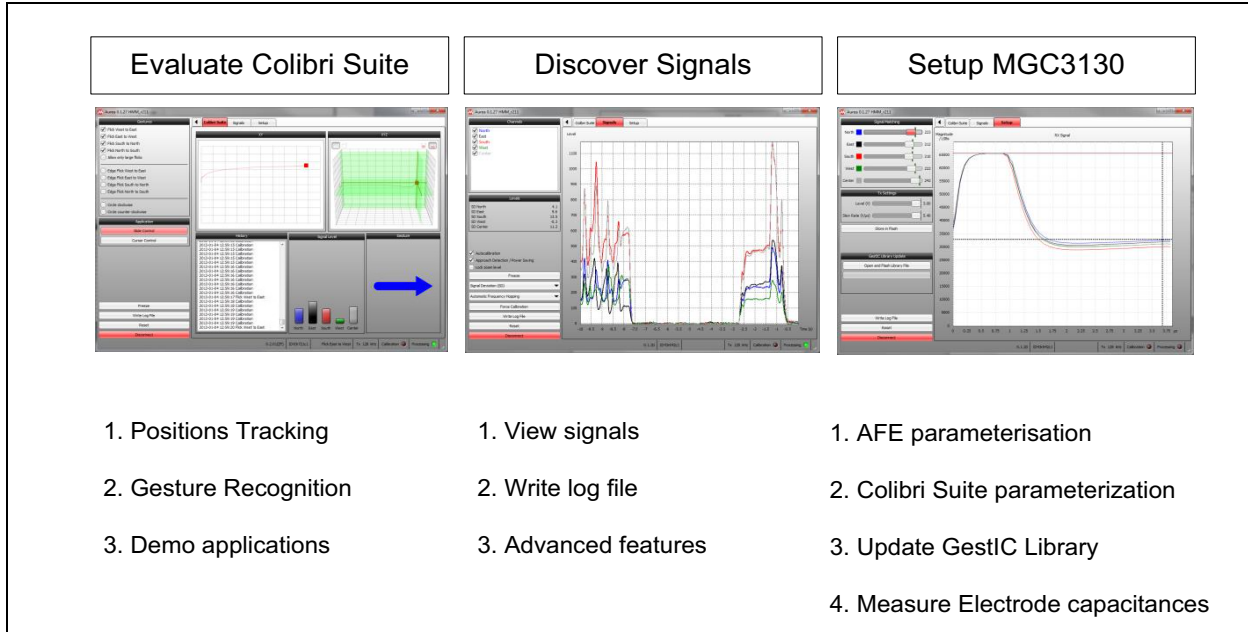
When the Hillstar Development Kit is connected to your PC for the first time, Windows requests the appropriate device driver and guides you through the installation process. Alternatively, you can install the driver manually, (e.g., using the device manager). An example for Windows 7 is given in **Appendix D. “Driver Installation Manual”**.

## 2.5 STEP 4: START AUREA

Aurea Graphical User Interface, shown in Figure 2-3, is included in the MGC3130 Software Package in the folder `02_Aurea`.

Open `Aurea.exe`. Aurea detects the connected device automatically and is ready for use.

**FIGURE 2-3: AUREA GRAPHICAL USER INTERFACE**



# MGC3130 Hillstar Development Kit User's Guide

---

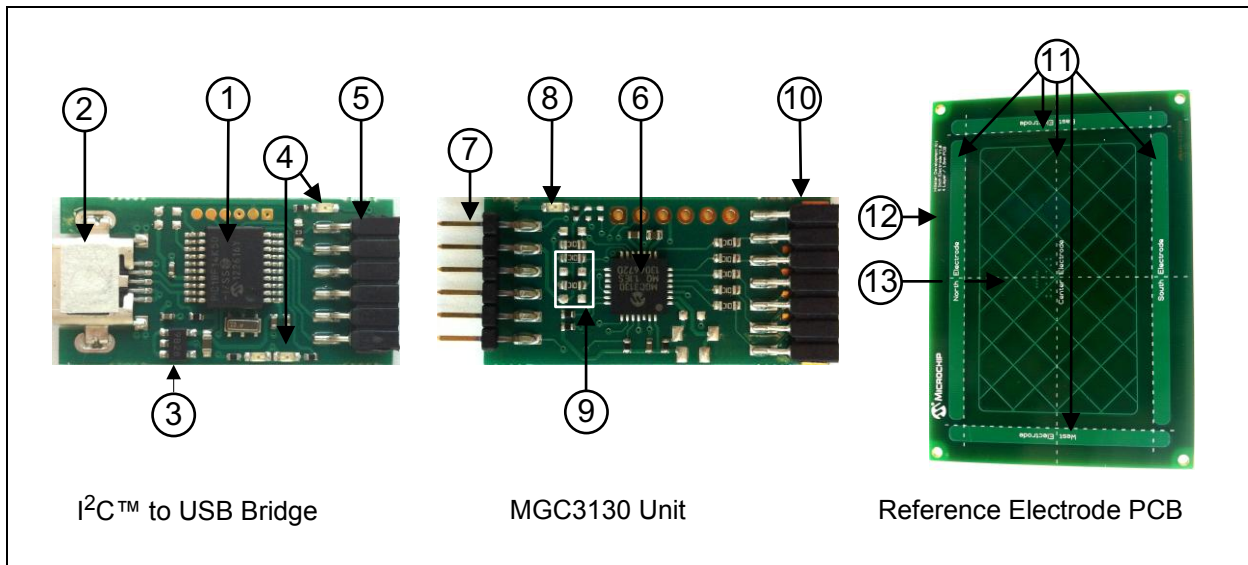
NOTES:

**Chapter 3. Hillstar Boards – Hardware Description**

**3.1 OVERVIEW**

The Hillstar key components are listed below and highlighted in Figure 3-1.

**FIGURE 3-1: HILLSTAR DEVELOPMENT KIT OVERVIEW**



**3.1.1 I<sup>2</sup>C™ to USB Bridge**

1. PIC18F14K50 USB microcontroller
2. USB mini-B connector
3. MCP1801T LDO voltage regulator (converts 5V USB to 3.3 V board supply)
4. Status LEDs (power, communication status)
5. Data interface: 6-pin socket for data communication and power supply

**3.1.2 MGC3130 Unit**

6. MGC3130 3D Tracking and Gesture Controller
7. Data interface: 6-pin header for data communication and power supply
8. Status LED (power)
9. Interface select
10. Electrode interface: 7-pin socket

**3.1.3 95x60 mm Reference Electrode PCB**

11. Receive electrodes
12. Acrylic cover glass (120 x 85 x 2 mm)
13. Electrode interface: 7-pin header (mounted on backside)

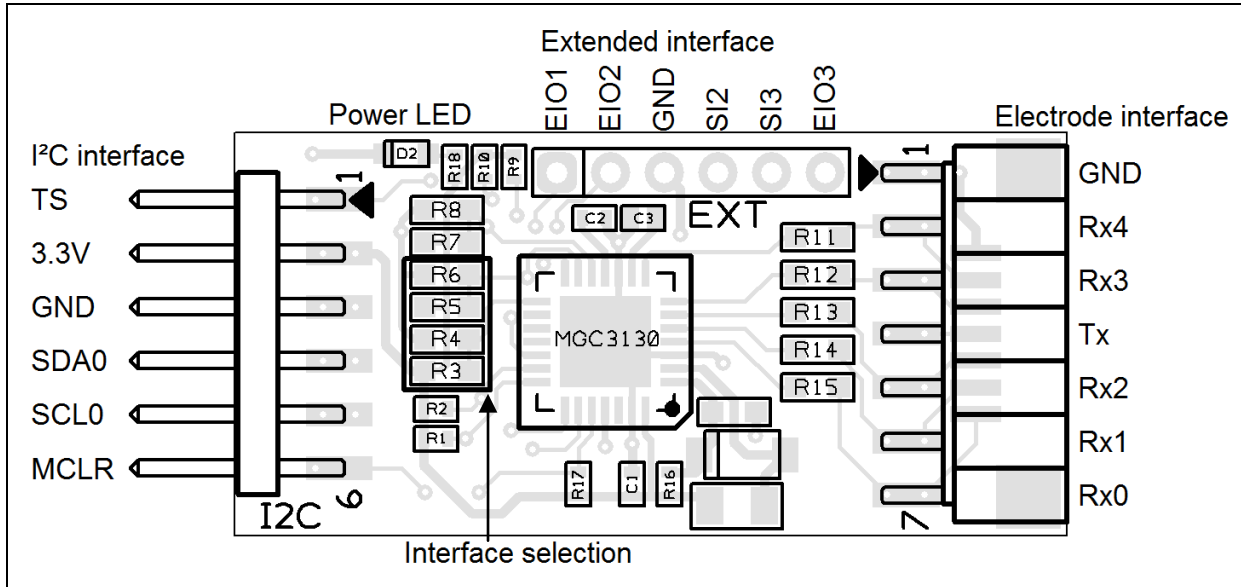
# MGC3130 Hillstar Development Kit User's Guide

The Gerber data of all Hillstar Development Kit components are included in the MGC3130 Hillstar Hardware Reference package and can be downloaded from Microchip's web site [www.microchip.com/GestICGettingStarting](http://www.microchip.com/GestICGettingStarting).

## 3.2 MGC3130 UNIT

The key element of the MGC3130 Unit is Microchip's MGC3130 3D Tracking and Gesture Controller. The layout print of the unit is shown in Figure 3-2.

**FIGURE 3-2: MGC3130 UNIT**



The unit provides a 2 mm 7-pin board-to-board connector (socket) to connect the electrode. The interface includes the following signals: GND, Rx4, Rx3, Tx, Rx2, Rx1, and Rx0. Alternatively, the board-to-board connector can be replaced by a 1 mm Flexible Printed Circuitry (FPC) connector which is prepared as a design option. The five Rx channels of the MGC3130 (Rx0...Rx4) are connected to the receive electrodes via 10 k $\Omega$  resistors in order to suppress irradiated high-frequency signals (R11, R12, R13, R14, and R15). The MGC3130 signal generator is connected via the Tx signal to the transmit electrode.

The data connection to the Hillstar I<sup>2</sup>C to USB Bridge is realized by a 6-pin 2 mm board-to-board connector (header). The interface includes the following signals: EIO0, 3.3V, GND, SDA0, SCL0, and MCLR. Alternatively, it is possible to use a 1 mm FPC connector which can be assembled to the bottom side.

The MGC3130 unit acts as an I<sup>2</sup>C slave device. Table 3-1 shows the configuration of the MGC3130 interface selection pins (IS1, IS2) which can be pulled to V<sub>DD</sub> or to GND via resistors (R3, R4, R5, and R6) to select the I<sup>2</sup>C slave address. The I<sup>2</sup>C device address 0x42 is set as default.

**TABLE 3-1: MGC3130 UNIT I<sup>2</sup>C™ INTERFACE SELECTION**

MGC3130 Interface Selection Pins		Mode (Address)	Assembly Option			
IS2	IS1		R3	R4	R5	R6
0	0	I <sup>2</sup> C™0 Slave Address = 0x42 (default)	n.p.	10 k $\Omega$	n.p.	10 k $\Omega$
1	0	I <sup>2</sup> C™0 Slave Address = 0x43	10 k $\Omega$	n.p.	n.p.	10 k $\Omega$

For Schematics, Layout and Bill of Material of the MGC3130 Unit please refer to Appendix A.

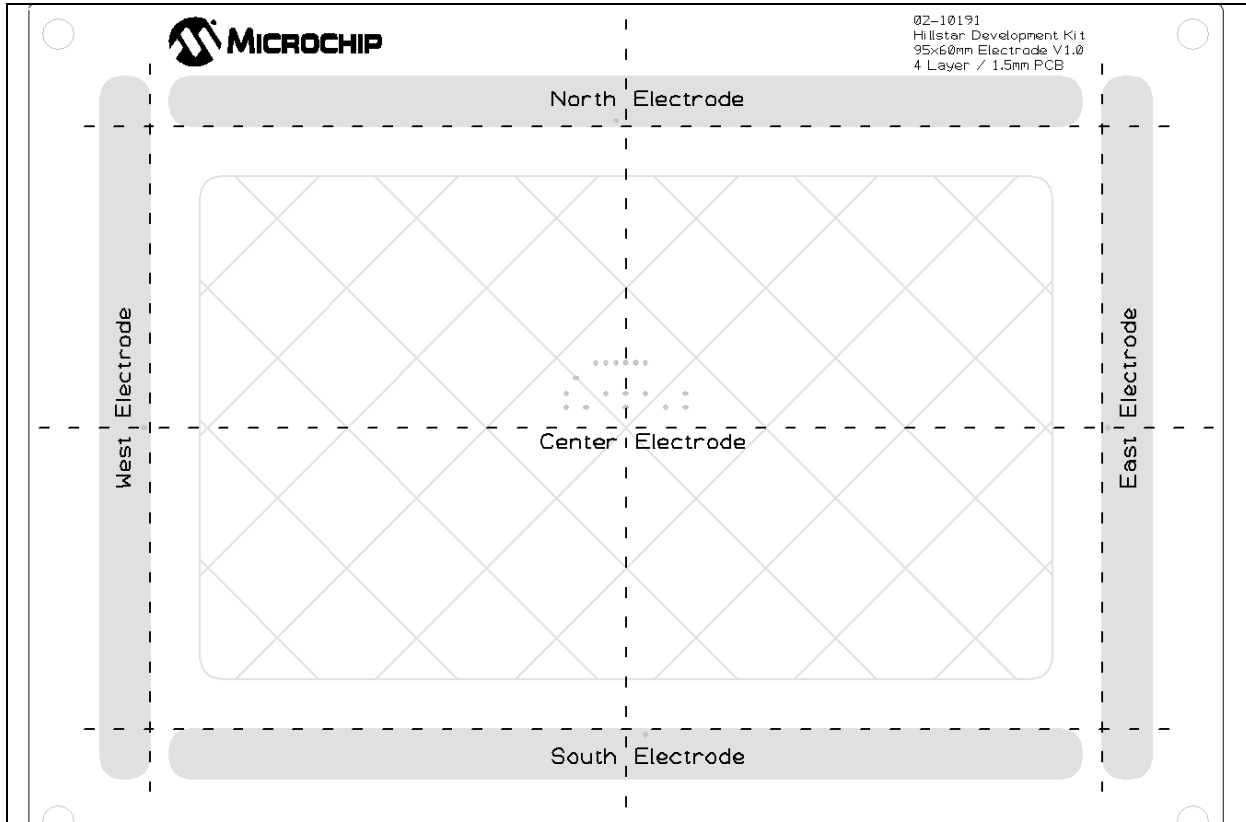


# Hillstar Boards – Hardware Description

## 3.3 HILLSTAR 95x60 mm REFERENCE ELECTRODE

The 95x60 mm Reference Electrode provided with the Hillstar Development Kit consists of one Tx and a set of five Rx electrodes (north, east, south, west, center), which are placed in two different layers. An additional ground layer is placed underneath the Tx electrode and shields the electrode's back from external influences.

FIGURE 3-3: HILLSTAR PCB ELECTRODE



The PCB is connected to the MGC3130 Unit by the 2 mm 7-pin board-to-board connector. The interface includes the following signals: GND, Rx4, Rx3, Tx, Rx2, Rx1, and Rx0.

The dimension of the board is 120 x 85 mm; the sensitive area is 95 x 60 mm.

The five Rx electrodes include four frame electrodes and one center electrode, as shown in Figure 3-3. The frame electrodes are named according to their cardinal directions: north, east, south and west. The dimensions of the four Rx frame electrodes define the maximum sensing area. The center electrode is structured (cross-hatched) to get a similar input signal level as the four frame electrodes.

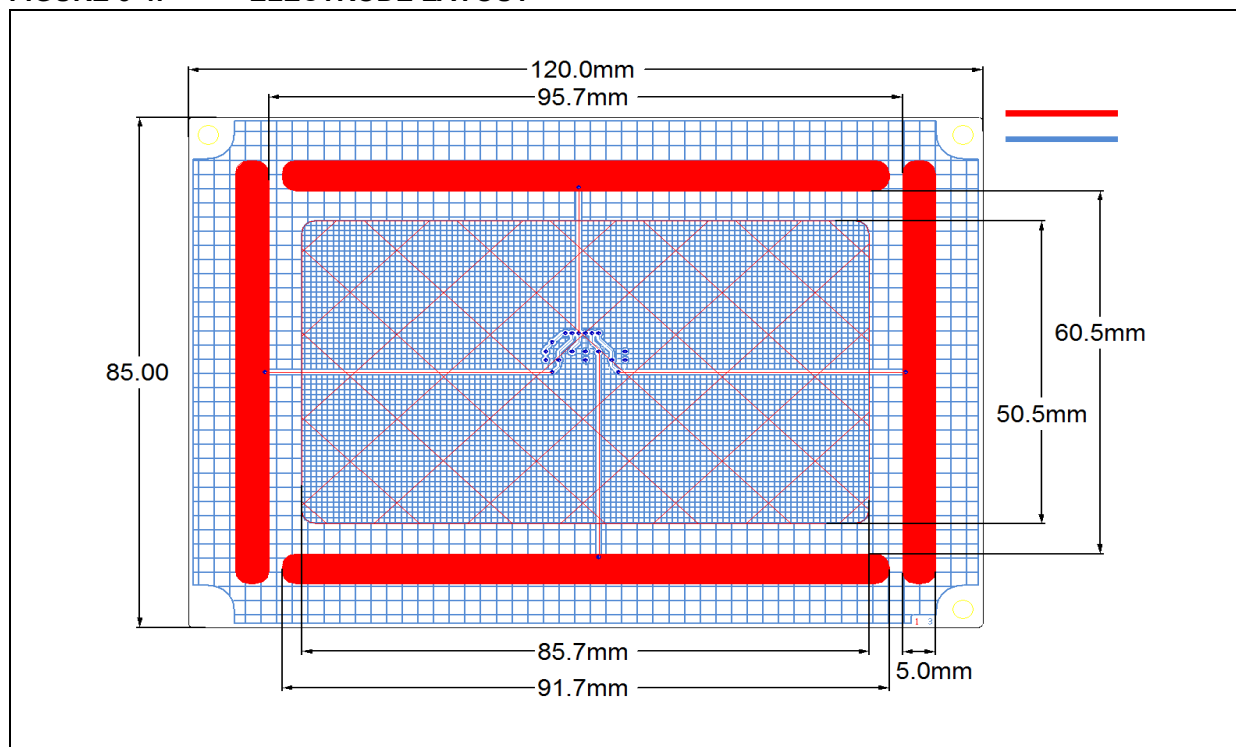
The Tx electrode spans over the complete area underneath the Rx electrodes. It is cross-hatched to reduce the capacitance between Rx and Tx ( $C_{RxTx}$ ). The Tx area below the center electrode covers 50% of the copper plane, the area around only 20%.

The Rx feeding lines are embedded into the Tx electrode in the third layer (refer to Figure 3-4 and Figure 3-5). This supports shielding of the feeding lines.

Dimensions are given in Table 3-2.

# MGC3130 Hillstar Development Kit User's Guide

**FIGURE 3-4: ELECTRODE LAYOUT**



**TABLE 3-2: HILLSTAR ELECTRODE DIMENSIONS**

	Length	Width	Design
<b>Horizontal Electrodes (Rx)</b>	91.7 mm	5 mm	solid
<b>Vertical Electrodes (Rx)</b>	70.5 mm	5 mm	solid
<b>Center Electrode (Rx)</b>	85.7 mm	50.5 mm	3% cross-hatched
<b>Tx Electrode (refer to Figure 3-4)</b>	120 mm	85 mm	
<b>Part I (under center electrode)</b>	85.7 mm	50.5 mm	50% cross-hatched
<b>Part II (outside Part I)</b>	120 mm	85 mm	20% cross-hatched
<b>Ground Area</b>	120 mm	85 mm	solid

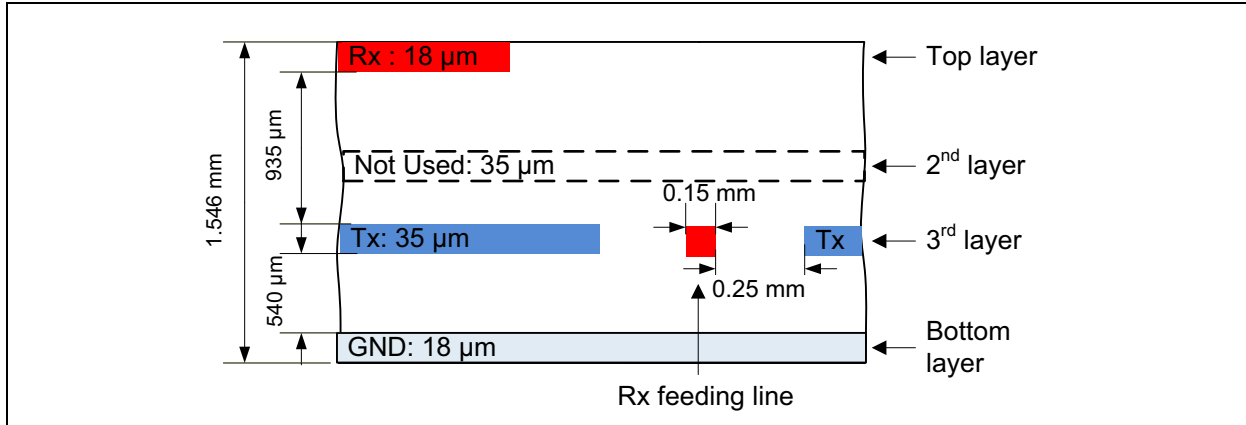
The electrode PCB is based on a 4-layer PCB design using FR4 material. Three functional layers are used:

- Layer 1 (Top): Rx electrodes
- Layer 3: Tx electrode and Rx feeding lines
- Layer 4 (Bottom): Ground

Layer 2 is not used.

# Hillstar Boards – Hardware Description

**FIGURE 3-5: PCB LAYER STACK**



In a target system design the GND layer is not required. It is added for the Hillstar sensing electrode as a shielding layer and shall simulate the presence of static components which are placed in a target device underneath the sensing electrodes.

**Note:** Please refer to the “MGC3130 GestIC<sup>®</sup> Design Guide” for the electrodes equivalent circuitry, capacitances ( $C_{RxTx}$ ,  $C_{RxG}$ ,  $Tx_{RxG}$ ) and their typical values.

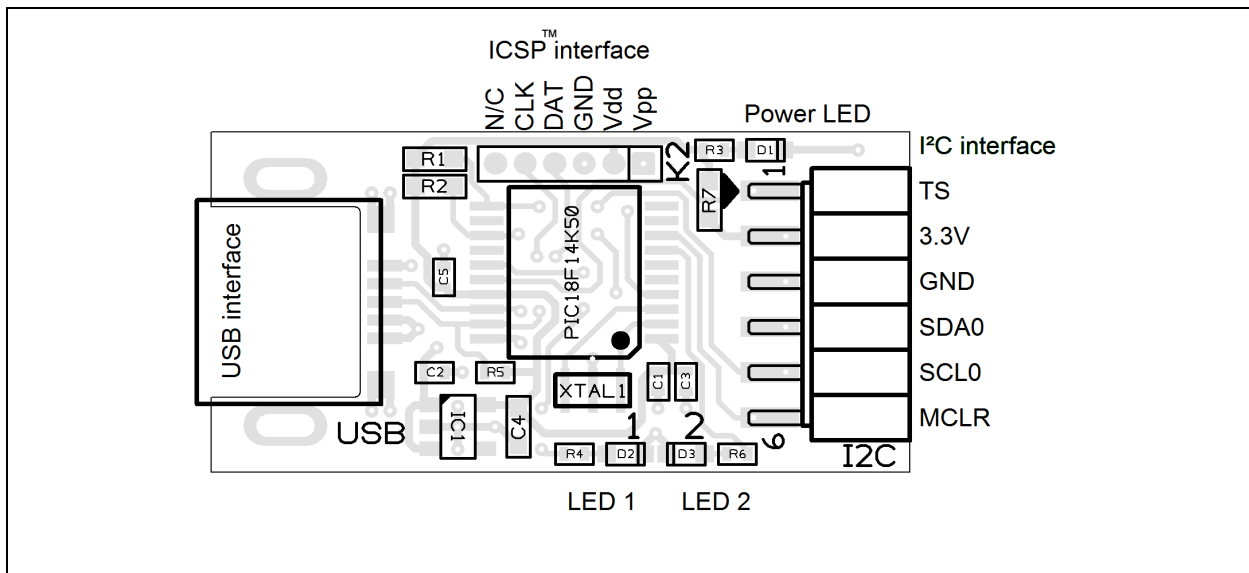
## 3.4 I<sup>2</sup>C TO USB BRIDGE

Connecting the MGC3130 Unit to a PC requires an I<sup>2</sup>C to USB Bridge. The Hillstar Bridge works as a Composite Device Class (CDC). It controls the USB transfer towards the host PC and handles the I<sup>2</sup>C communication with the MGC3130 Unit. Moreover, it provides 3.3V power supply and the MCLR signal to the MGC3130 Unit.

The bridge function is handled by Microchip’s PIC18F14K50 USB microcontroller.

The board is equipped with a mini USB connector (Type A) and a 2 mm 6-pin female board-to-board connector for the I<sup>2</sup>C interface. The interface to the MGC3130 Unit includes the following signals: EIO0, 3.3V, GND, SDA0, SCL0, and MCLR. Please refer to Figure 3-6.

**FIGURE 3-6: I<sup>2</sup>C™ TO USB BRIDGE**



# MGC3130 Hillstar Development Kit User's Guide

The I<sup>2</sup>C to USB Bridge is powered via the USB port. Microchip's Low Dropout (LDO) Voltage Regulator MCP1801 is used to transform the 5V USB power to 3.3V required for the PIC18F14K50. By default, 3.3V are also routed to the MGC3130 Unit via the I<sup>2</sup>C interface. The 3.3V power supply towards the MGC3130 Unit can be cut by removing the 0Ω resistor R7.

The LEDs indicate the following:

- POWER – signals that the I<sup>2</sup>C to USB Bridge is powered (3.3V)
- LED1 – blinks fast (~10 Hz) to indicate that there is no USB connection established
- LED1 – blinks slow (~1 Hz) to indicate that the USB connection is established
- LED 2 – is on when there is data on the I<sup>2</sup>C bus
- LED 2 – is off when there is no data on the I<sup>2</sup>C bus

The communication between Bridge and MGC3130 Unit is accomplished via a 2-wire I<sup>2</sup>C compatible serial port. Please refer to Figure 3-7.

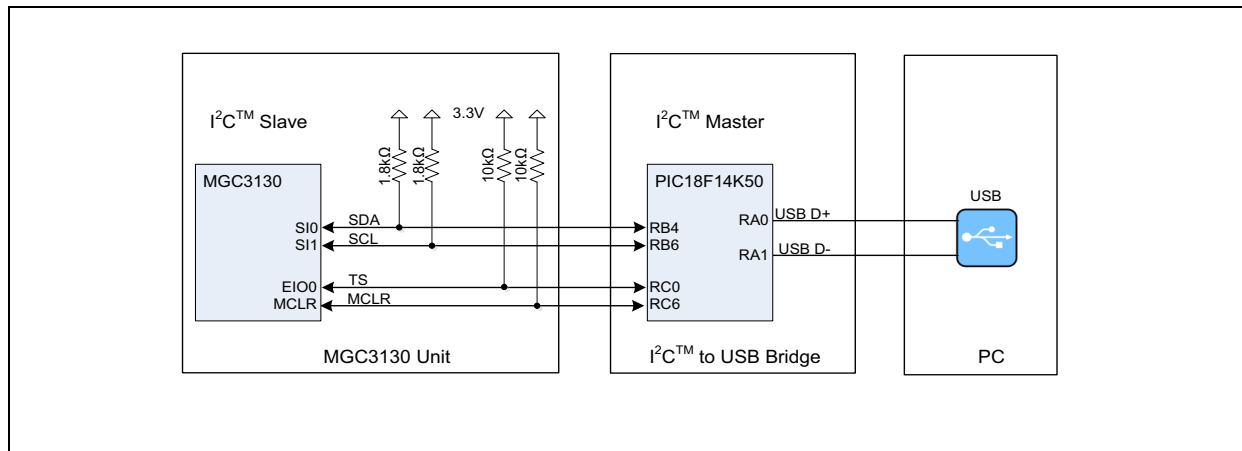
In addition, the Hillstar Development Kit integrates an open-drain transfer status line (TS) and the MGC3130 MCLR signal, according to the MGC3130 reference circuitry. TS is connected to the RC0 pin of the PIC18F14K50 and MCLR to RC6.

For a detailed description of the I<sup>2</sup>C interface refer to the "MGC3130 Single-Zone 3D Gesture Controller Data Sheet" (DS40001667).

The default I<sup>2</sup>C address of the bridge is set to 0x42 but can also be switched to 0x43 by changing the firmware running on the PIC18F14K50.

**Note:** To update the PIC18F14K50 firmware, please refer to 'MGC3130 PIC18F14K50 Host Reference Code', available on [www.microchip.com/GestICGettingStarted](http://www.microchip.com/GestICGettingStarted).

**FIGURE 3-7: I<sup>2</sup>C™ AND USB DATA INTERFACE**



For Schematics, Layout and Bill of Material of the I<sup>2</sup>C to USB Bridge please refer to Appendix A.

---

---

## Chapter 4. Design In: Hillstar In Target Application

---

---

### 4.1 INTRODUCTION

The Hillstar Development Kit is designed to support an easy integration of Microchip's MGC3130 3D Tracking and Gesture Controller into customer's applications.

The three Hillstar PCBs can be plugged to a PC via USB cable and used for evaluation of MGC3130 chip and GestIC technology.

During the customer's design-in process the individual boards can be combined according to the customers need.

Three examples are given below:

- Combine MGC3130 Unit and I<sup>2</sup>C to USB Bridge to evaluate customized electrodes
- Use I<sup>2</sup>C to USB Bridge to parameterize and debug the MGC3130 application circuitry in the customer's design (in-circuit)
- Combine MGC3130 Unit and Electrodes to develop gesture-driven applications for PC-based or embedded software environments

For in-circuit parameterization and debugging it is mandatory to control the MGC3130 via Aurea Control Software. For that purpose, the customer's application should provide an appropriate hardware or software interface.

### 4.2 INTEGRATION EXAMPLES

The following figures show typical hardware circuits for MGC3130 integration into a customer's application.

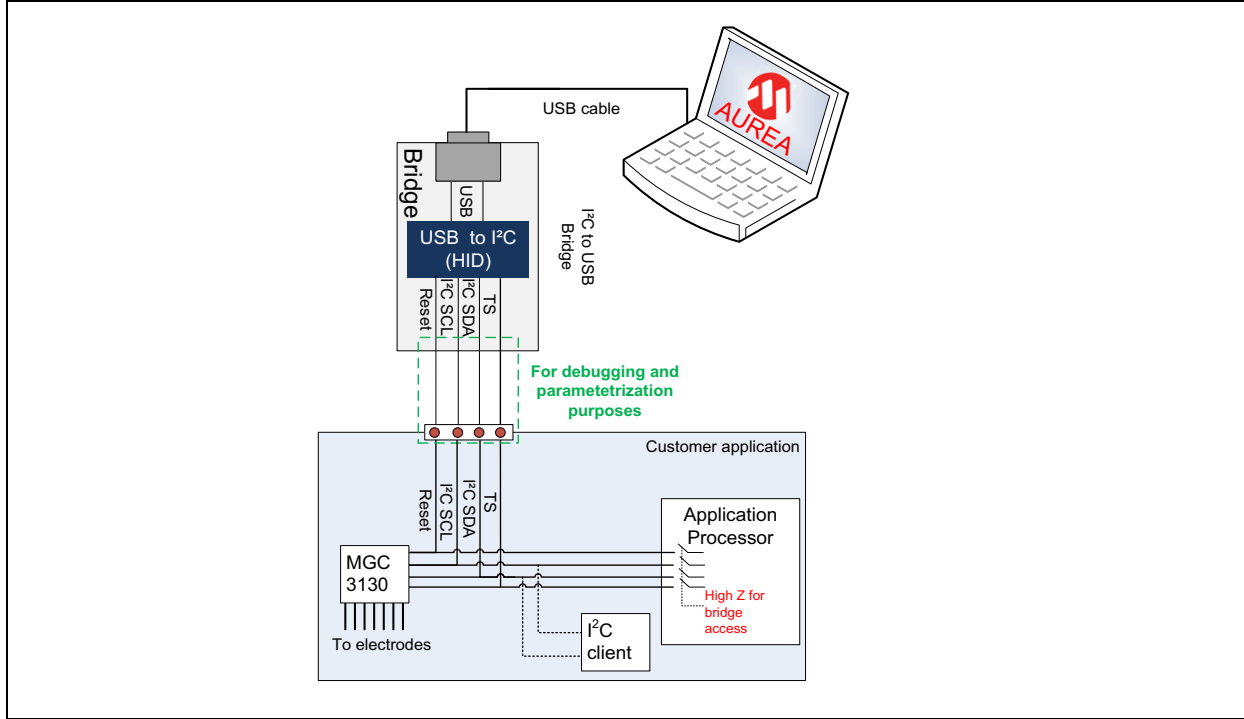
Figure 4-1 and Figure 4-2 show the control via I<sup>2</sup>C and an external PC. The Hillstar I<sup>2</sup>C to USB Bridge acts as an I<sup>2</sup>C master, the application processor I<sup>2</sup>C should be:

- Switched off (I<sup>2</sup>C lines configured as high Z, refer to Figure 4-1)
- Switched to Slave or Listen mode or
- Disconnected (through an external switch, refer to Figure 4-2)

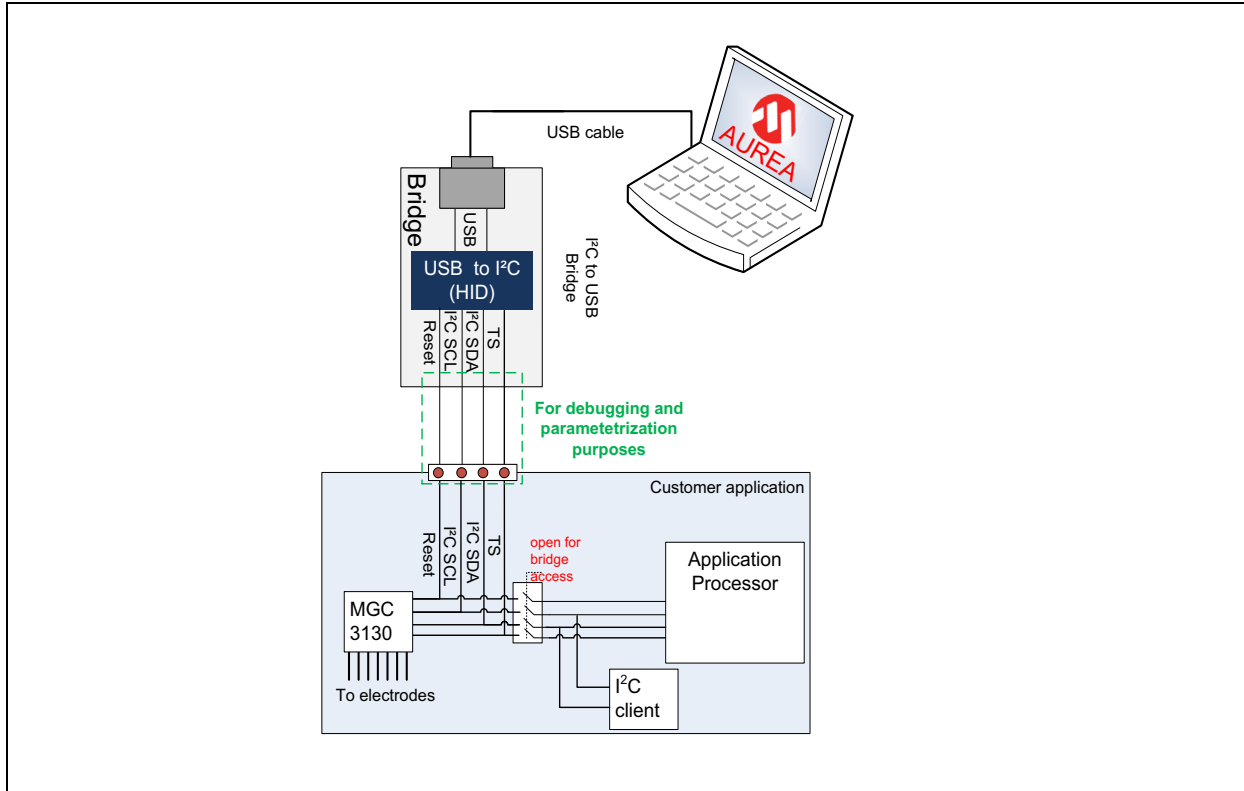
As an alternative, it is also possible to establish a USB connection between the application processor and a PC without using an I<sup>2</sup>C to USB Bridge. Please refer to Figure 4-3.

# MGC3130 Hillstar Development Kit User's Guide

**FIGURE 4-1: MGC3130 PARAMETERIZATION CIRCUIT WITH INTERNAL SWITCH**

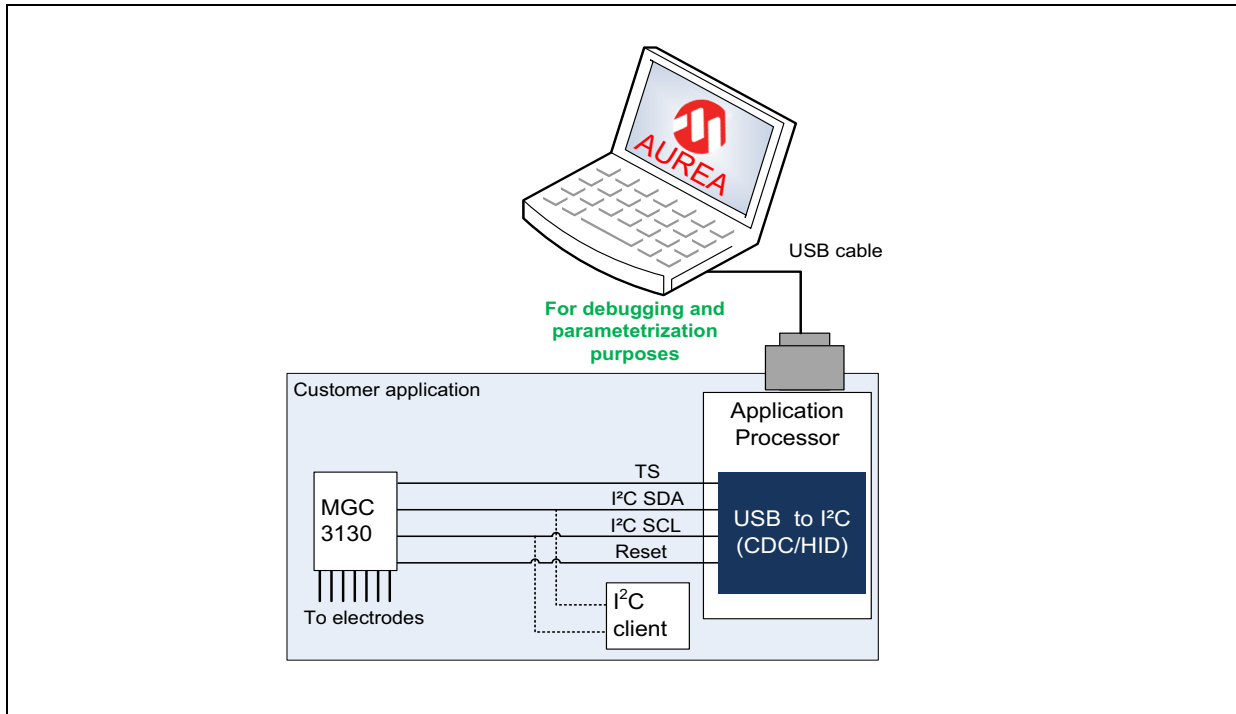


**FIGURE 4-2: MGC3130 PARAMETERIZATION CIRCUIT WITH EXTERNAL SWITCH**



# Design In: Hillstar In Target Application

**FIGURE 4-3: MGC3130 PARAMETERIZATION CIRCUIT FOR USB BASED APPLICATIONS**



**TABLE 4-1: MGC3130 PARAMETERIZATION CIRCUITS COMPARISON**

Parameterization Circuit	Advantages	Drawbacks
<b>With Internal Switch</b>	Easy Approach	Processor pins need to be switchable to high Z
	Low hardware efforts	No other clients can be controlled during Aurea access
<b>With External Switch</b>	Communication to other I <sup>2</sup> C™ clients not interrupted	Additional hardware switch
<b>USB Based Applications</b>	No hardware efforts	Additional software efforts
	Works if other I <sup>2</sup> C™ clients connected to the bus	

# MGC3130 Hillstar Development Kit User's Guide

---

NOTES:



---

---

## Chapter 5. Troubleshooting

---

---

### Troubleshooting Information

***Power LED does not illuminate***

In case the power LED does not illuminate it is likely that the board is not powered.

Possible Solutions:

- Check the board is connected to your PC's USB port.
- Change the USB cable or use a different USB port on your PC.
- Check if the PC is switched on.

***LED 1 blinks fast***

When LED 1 blinks fast (~10 Hz) the USB connection is not established towards the PC.

Possible Solutions:

- Make sure the Windows CDC driver is installed (refer to **Appendix D. "Driver Installation Manual"**).
- Make sure the MGC3130 Unit and the I<sup>2</sup>C™ to USB Bridge are already connected before plugging in the USB connection (refer to **Section 2.2 "Step 1: Build-up Development Kit"**).
- Reconnect the board by unplugging and plugging in again the USB connection.

***Signal streaming stops***

Signal stream in Aurea GUI stops when there is no approach towards the sensing area. This behavior is intended. When using the Aurea GUI, the Wake-up on Approach feature is automatically enabled.

Possible Solutions:

Disable the Wake-up on Approach feature in the Real-Time Control bar of Aurea by unchecking the Approach Detection/Power Saving check box for continuous signal streaming.

***No Position data displayed, Electrode signals are zero***

Signal matching parameters have been mismatched and accidentally stored into the Flash.

Possible Solutions:

- Perform "Autoparameterization" in the AFE Parameterization of **Aurea Setup** tab. Make sure there is no hand approach towards the electrodes during autoparamterization process.
- Restore the default Signal Matching parameters by re-flashing the original MGC3130 GestIC® Library file.

***LED 1 and 2 on I<sup>2</sup>C™ to USB Bridge are off***

When LED 1 and LED 2 on the I<sup>2</sup>C™ to USB Bridge are off but the power LED is on, the PIC18F14K50 is in Bootloader Update mode and therefore not operating code. The PIC18F14K50 will start in Bootloader Update mode in case the MGC3130 Unit is not connected to the I<sup>2</sup>C™ to USB Bridge.

Possible Solutions:

- Please disconnect the I<sup>2</sup>C™ to USB Bridge from USB. Connect the MGC3130 Unit and the I<sup>2</sup>C™ to USB Bridge first and then plug in the USB connection.

# MGC3130 Hillstar Development Kit User's Guide

---

NOTES:

**Appendix A. Schematics**

**A.1 INTRODUCTION**

This appendix contains the MGC3130 Hillstar Development Kit schematic and Bill of Materials.

**A.2 BILL OF MATERIALS**

**TABLE A-1: I<sup>2</sup>C™ TO USB BRIDGE BILL OF MATERIALS**

Qty.	Description	Name
1	Connector, Mini USB 5-pin Type B, SMD	BU1
1	Connector, 2 mm socket 6-pin, SMD	BU2
1	Capacitor, 100 nF, 10%, X7R, SMD 0402	C1
3	Capacitor, 1 µF, 10%, X5R, 10 V, SMD 0402	C2, C3, C5
1	Capacitor, 10 µF, 20%, X5R, 6.3 V, SMD 0603	C4
3	LED, 571 nm, green clear, 0603 SMD	D1, D2, D3
1	IC, MCP1801T LDO, Voltage Regulator, 3.3V, 150 mA, 5-Pin SOT-23	IC1
1	IC, PIC18F14K50 USB Flash Microcontroller, 20-Pin SSOP	IC2
3	Resistor, 1 kΩ, 1%, 1/16W, SMD 0402	R3, R4, R6
1	Resistor, 150 kΩ, 1%, 1/16W, SMD 0402	R5
1	Resistor, 0 kΩ, 1%, 1/16W, SMD 0603	R7
1	Crystal, 12 MHz, 33 pF, SMD	XTAL1

**TABLE A-2: HILLSTAR – I<sup>2</sup>C™ TO USB BRIDGE MOUNTING OPTION**

Qty.	Description	Name
1	Connector, 1 mm FPC 6-pin, SMD	ST1

# MGC3130 Hillstar Development Kit User's Guide

---

**TABLE A-3: HILLSTAR – MGC3130 UNIT BILL OF MATERIALS**

Qty.	Description	Name
1	Connector, 2 mm socket 7-pin, SMD	BU1
1	Connector, 2 mm header 6-pin, SMD	ST1
1	Capacitor, 100 nF, 10%, X7R, SMD 0402	C1
2	Capacitor, 4,7 $\mu$ F, 20%, X5R, 6.3V, SMD 0402	C2, C3
1	LED, 571 nm green clear, 0603 SMD	D2
1	IC, MGC3130, 28-Pin QFN	IC1
2	Resistor, 1,8 k $\Omega$ , 1%, 1/16W, SMD 0402	R1, R2
8	Resistor, 10 k $\Omega$ , 1%, 1/16W, SMD 0603	R4, R6, R7, R11, R12, R13, R14, R15
1	Resistor, 0 k $\Omega$ , 1%, 1/16W, SMD 0402	R16
1	Resistor, 10 k $\Omega$ , 1%, 1/16W, SMD 0402	R17
1	Resistor, 1 k $\Omega$ , 1%, 1/16W, SMD 0402	R18

**TABLE A-4: HILLSTAR – MGC3130 UNIT MOUNTING OPTION**

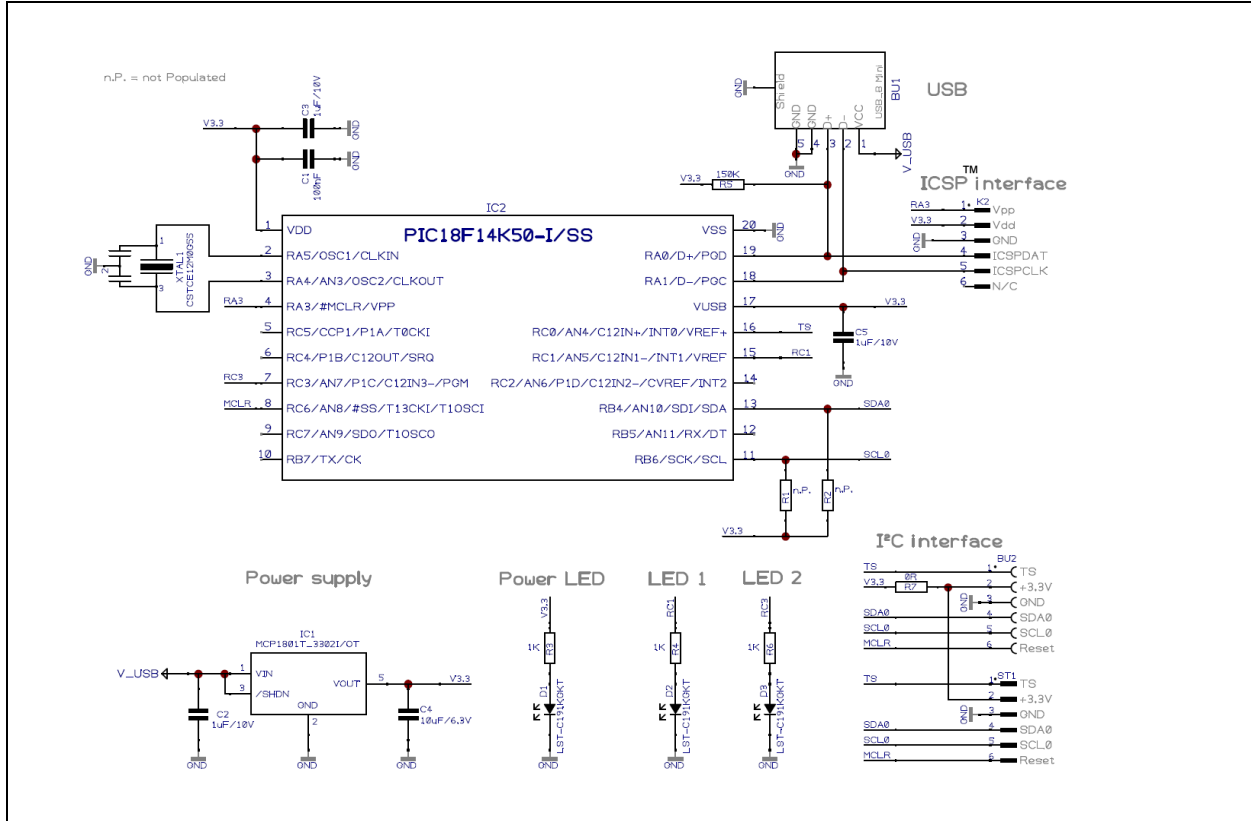
Qty.	Description	Name
1	Connector, 1 mm FPC 6-pin, SMD	ST3

**A-5: HILLSTAR – ELECTRODE BILL OF MATERIALS**

Qty.	Description	Name
1	Connector, 2 mm header 7-pin, SMD	ST1

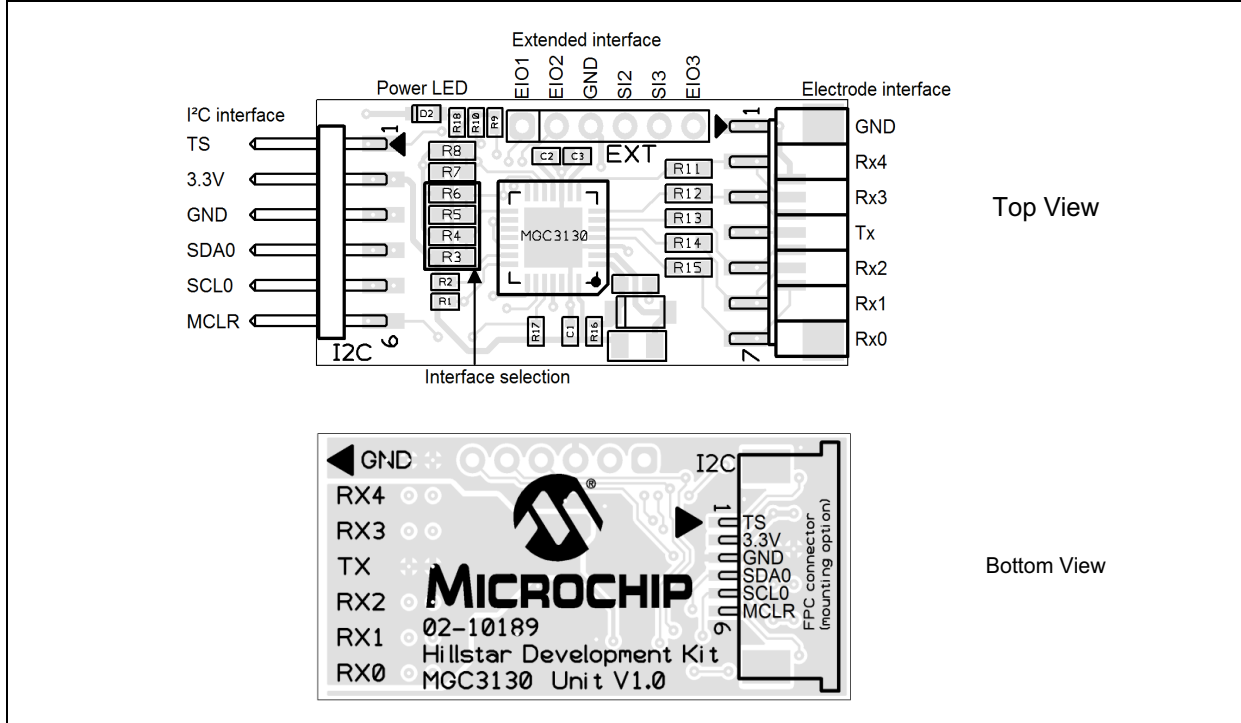
## A.3 BOARD – SCHEMATICS AND LAYOUT

FIGURE A-1: HILLSTAR GestIC® UNIT SCHEMATIC

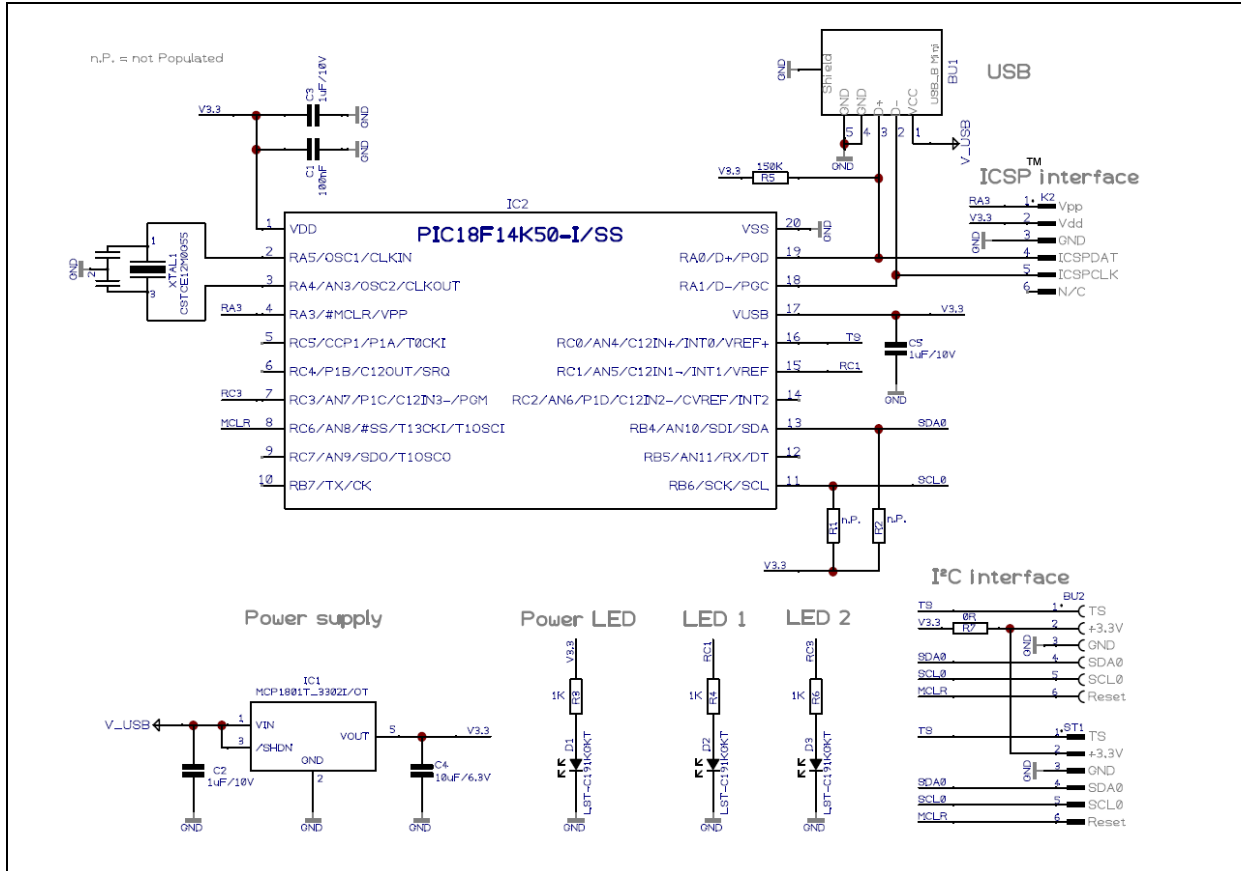


# MGC3130 Hillstar Development Kit User's Guide

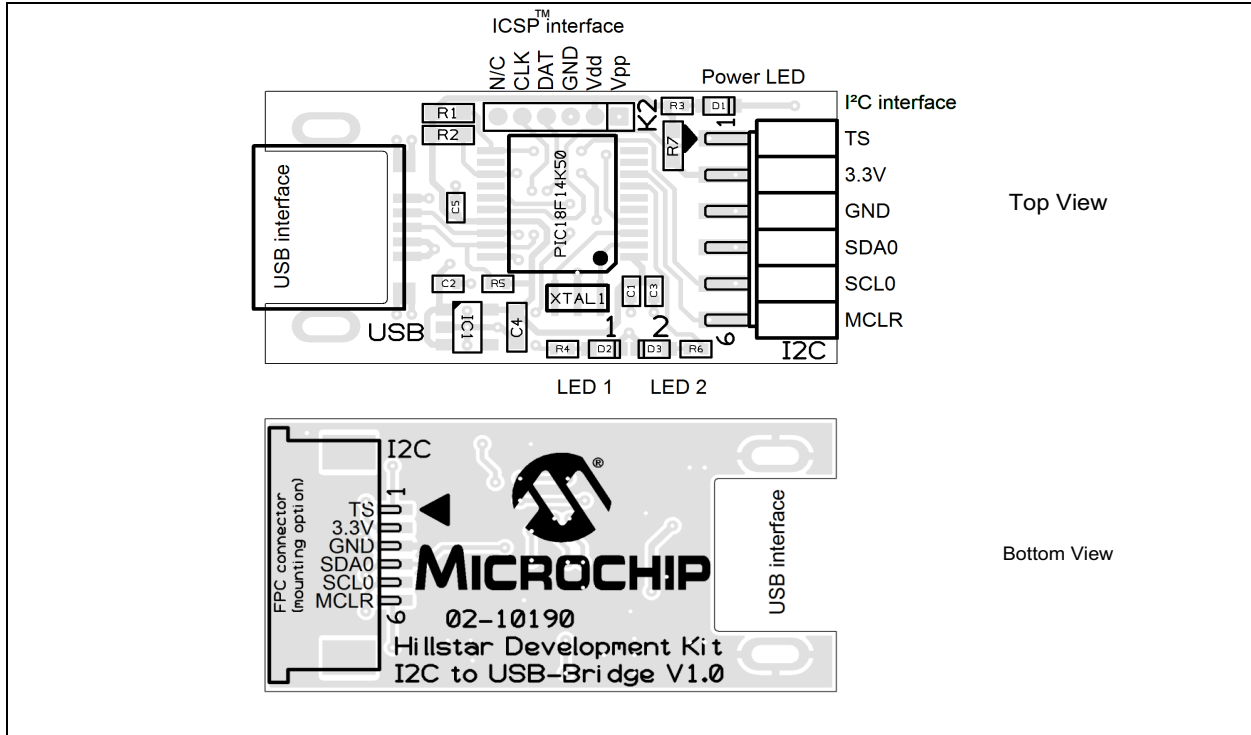
**FIGURE A-2: ASSEMBLY OF MGC3130 UNIT**



**FIGURE A-3: HILLSTAR I<sup>2</sup>C™ TO USB BRIDGE SCHEMATIC**



**FIGURE A-4: ASSEMBLY OF HILLSTAR I<sup>2</sup>C™ TO USB BRIDGE**



# MGC3130 Hillstar Development Kit User's Guide

---

NOTES:



**Appendix B. Sensitivity Profile and Capacitances**

**B.1 INTRODUCTION**

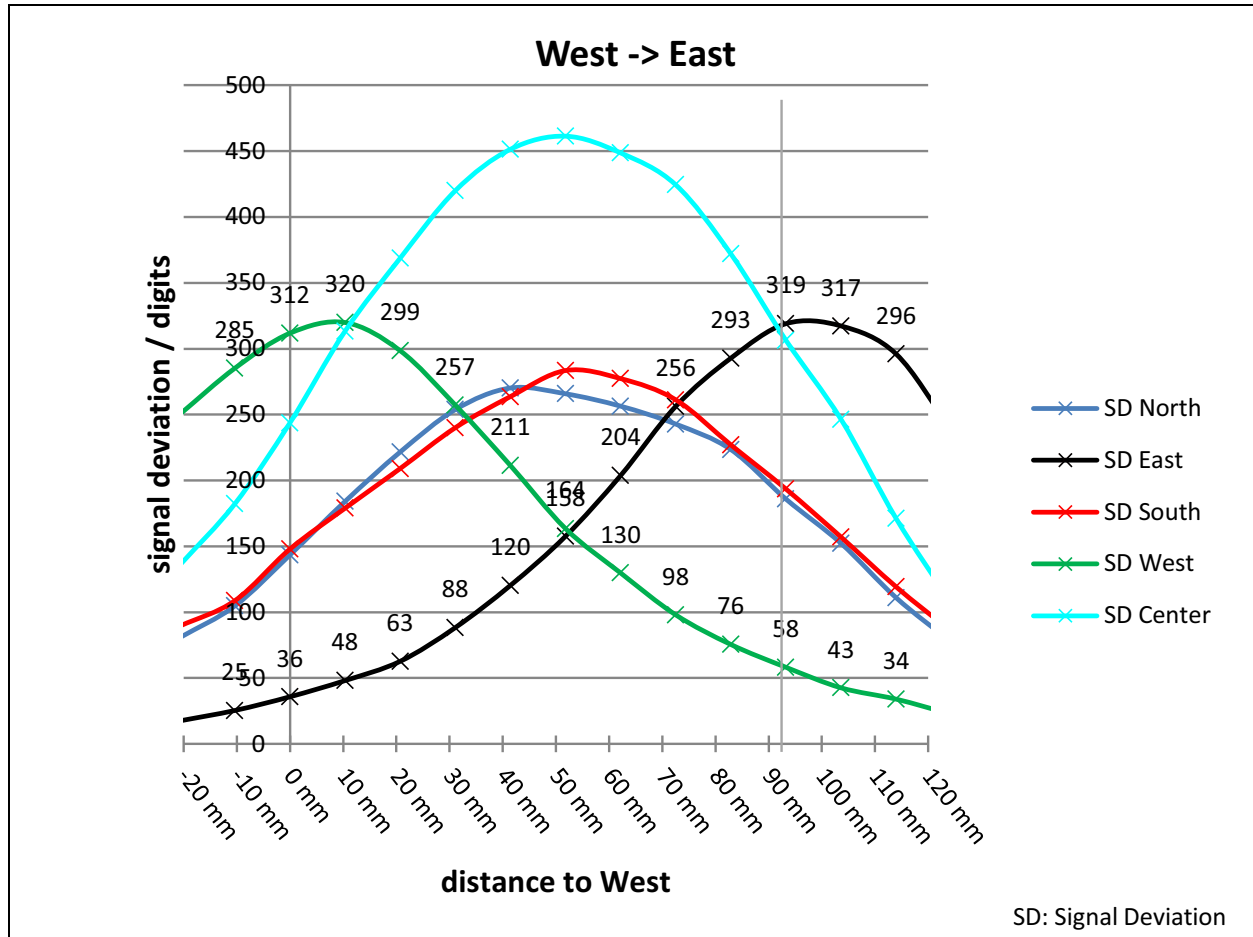
This appendix contains the sensitivity profile and the electrode capacitances of the Hillstar Development Kit hardware.

The measurement procedure of both, the sensitivity profile and the electrode capacitances are outlined in "MGC3130 GestIC® Design Guide".

**B.2 SENSITIVITY PROFILES**

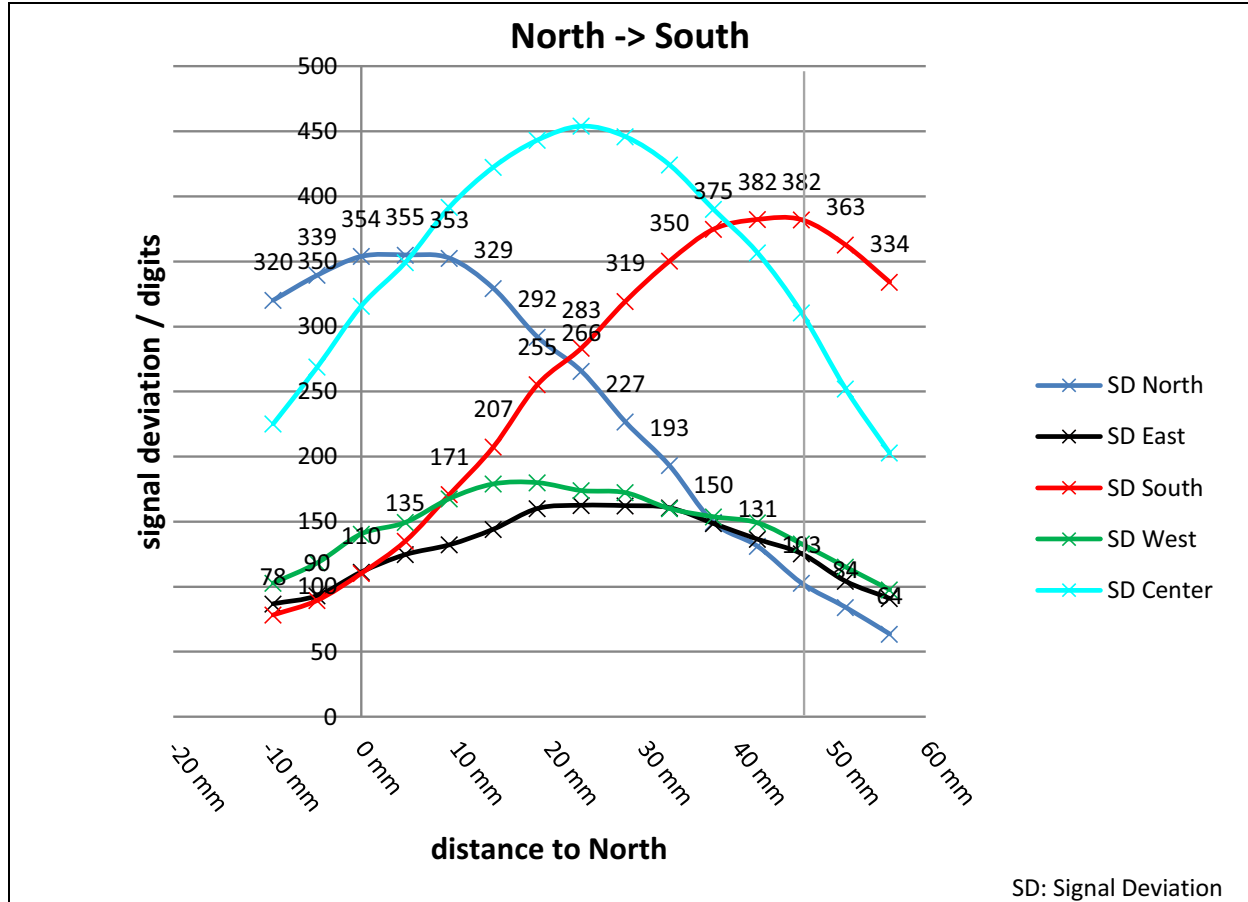
The sensitivity profiles were conducted using a 40x40x70 mm hand brick and a 30 mm spacer brick.

**FIGURE B-1: SENSITIVITY PROFILE FROM WEST TO EAST**



# MGC3130 Hillstar Development Kit User's Guide

FIGURE B-2: SENSITIVITY PROFILE FROM NORTH TO SOUTH



## B.3 ELECTRODE CAPACITIES

The capacitances between the Rx electrodes and GND ( $C_{RXG}$ ) does not include the 5 pF input capacitance of the MGC3130 Rx input buffer ( $C_{Buf}$ ).

TABLE B-3: HILLSTAR ELECTRODE CAPACITIES

Channel	$C_{RXG}$	$C_{RXTX}$
North	9 pF	20 pF
East	9 pF	18 pF
South	9 pF	20 pF
West	8 pF	18 pF
Center	7 pF	65 pF

$$C_{TXG} = 590 \text{ pF}$$

---

---

## Appendix C. Parameterization Support

---

---

### C.1 HOW TO BUILD A HAND BRICK

For parameterization and performance evaluation of the customer's electrode design, the Hillstar Development Kit contains a set of hand and spacer bricks. The hand brick is a conductive block of 40x40x70 mm and represents a human hand. It must be connected to ground via cable in order to simulate the grounding conditions of the human body.

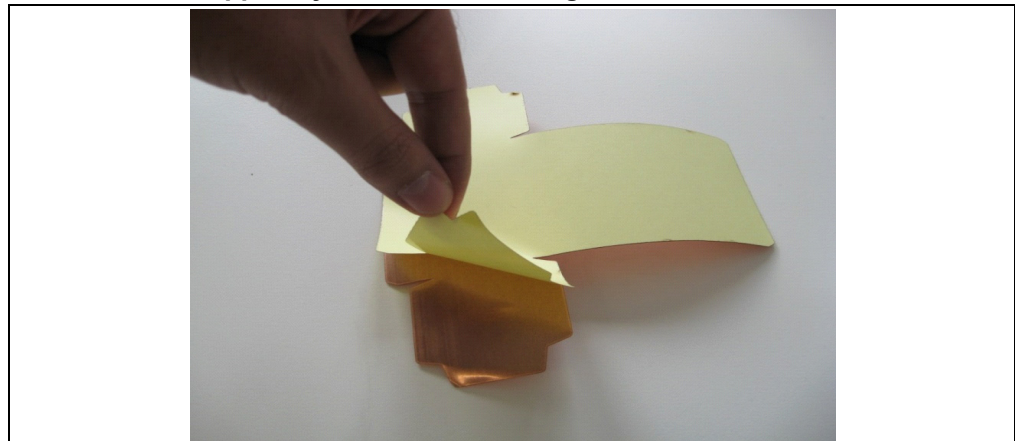
The Hillstar package contains an assembly set to build the hand brick consisting of a Styrofoam block (40x40x70 mm) and an adhesive copper foil.

The following section explains how to assemble the hand brick.

1. **Take the copper layer and the Styrofoam block with the dimensions of (40x40x70 mm).**



2. **Revert the copper layer and remove the glue foil.**



# MGC3130 Hillstar Development Kit User's Guide

---

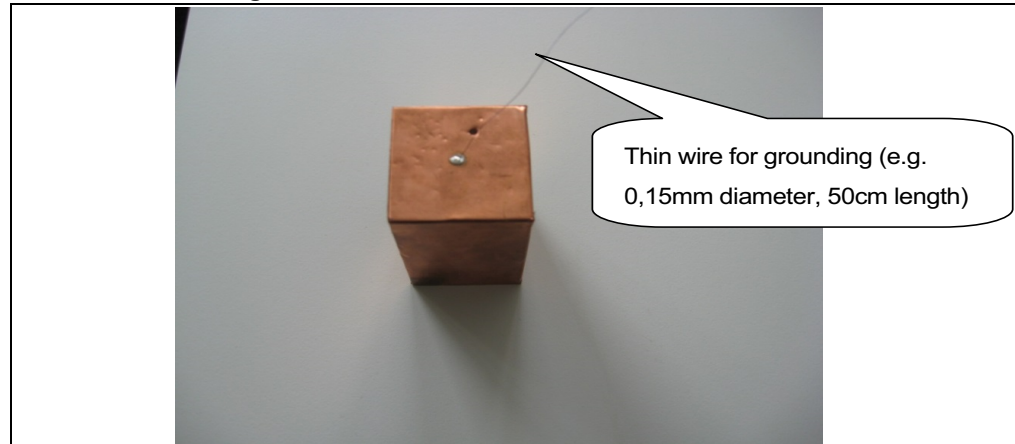
3. Place the Styrofoam block on the copper layer exactly on the middle. Be careful to be accurate! Fold the copper. Follow along the inside lines, and fold the copper inward. Start with right, left sides and then with middle part. Align the folds.



4. Finish up your box. Tape all of the sides together, and you're done.



5. Solder a thin wire (approx. 50 cm) on the top of the brick which will be connected later to ground.



6. Finished.

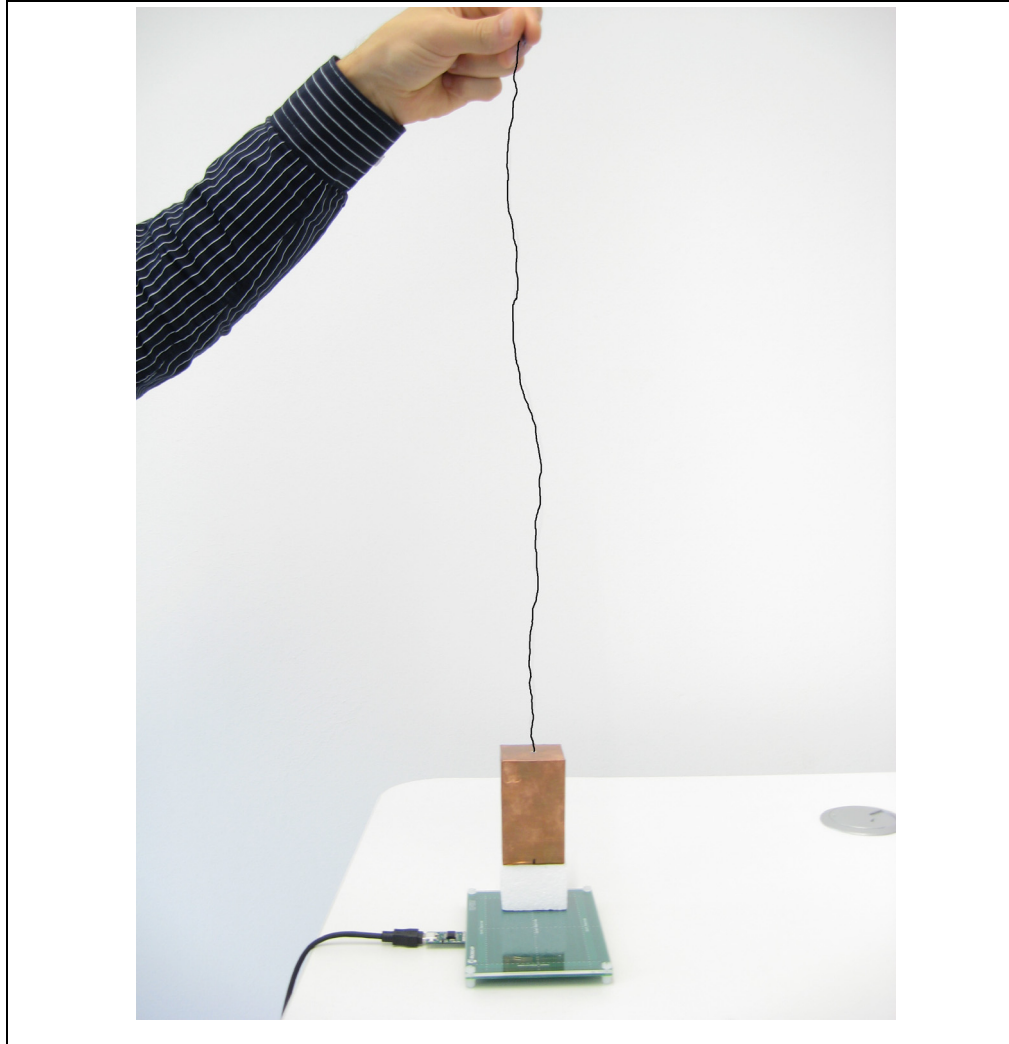
## C.2 USAGE OF THE HAND BRICK AS ARTIFICIAL HAND

For parameterization and performance evaluation purposes of the customer's electrode design, the kit contains a set of hand and spacer bricks. This artificial hand brick simulates Human Hand effect and is made of a Styrofoam block covered with light copper and has a fixed size. Spacer bricks (Styrofoam block without copper layer) are used to position the hand brick in different heights to the electrode. Because of a  $\epsilon_r \approx 1$  of Styrofoam, the spacer brick does not influence the measurement results.

For quick parameterization, the ground wire connected to the hand brick should be maintained using your hand which emulates the ground connection. The wire should be hold at 50 cm minimum and the line should also be straight to avoid any influence to the system sensitivity as shown in Figure C-1.

For parameterization process, please refer to "*MGC3130 GestIC<sup>®</sup> Design Guide*" and the appropriate wizards in Aurea PC software.

FIGURE C-1: USAGE OF ARTIFICIAL HAND



---

---

## Appendix D. Driver Installation Manual

---

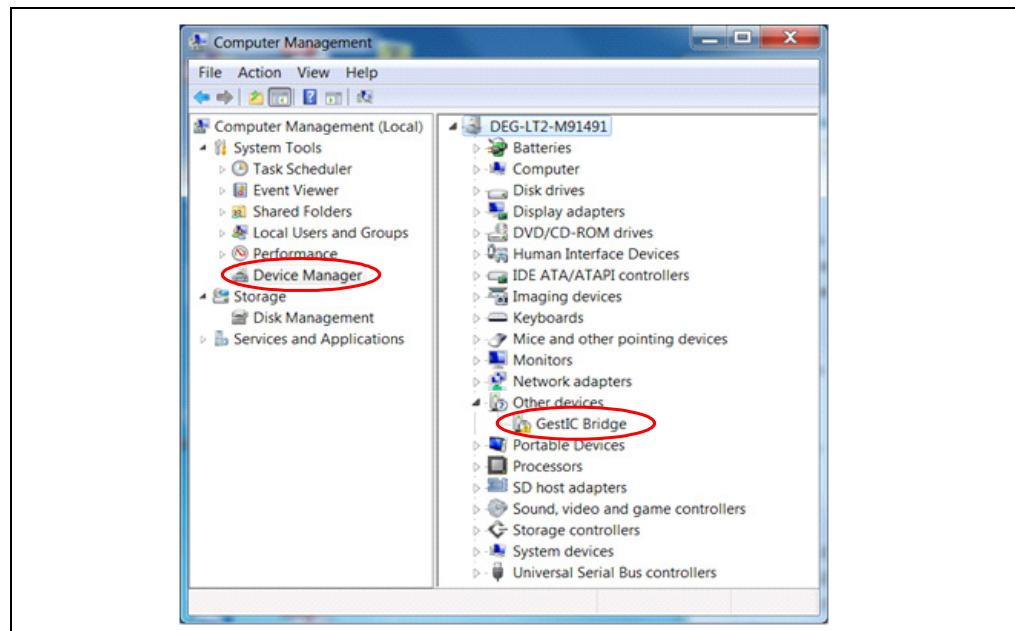
---

Go through the following steps to manually install the Windows CDC Driver on your PC.

### D.1 OPEN DEVICE MANAGER

While the Hillstar Development Board is connected to your PC press **Start**, right-click on **Computers** and select **Manage**. This will bring up the **Computer Management** window shown in Figure D-1. On the left sidebar select **Device Manager**.

**FIGURE D-1: COMPUTER MANAGEMENT**

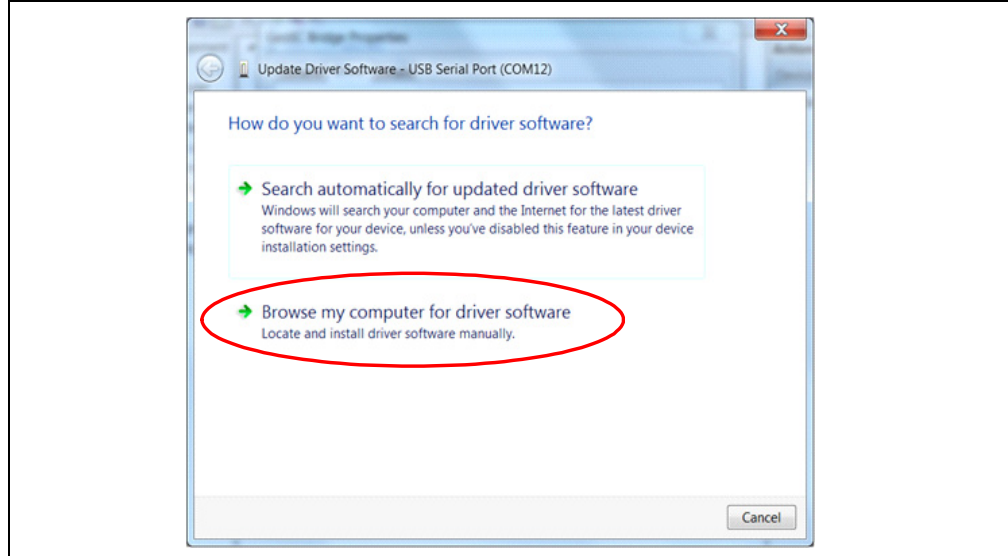


### D.2 SELECT DEVICE

1. Right Click on **GestIC Bridge** and select **Update Driver Software**.
2. Select **Search Method**
3. The window shown in Figure D-2 will open. Choose **Browse my Computer** for driver software.

# MGC3130 Hillstar Development Kit User's Guide

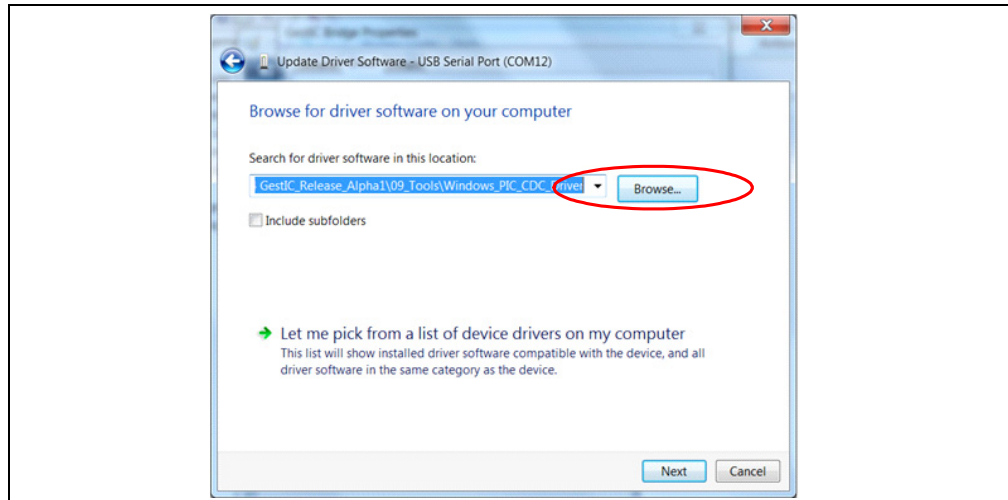
**FIGURE D-2: Update Driver Software**



## D.3 LOCATE DRIVER

1. Click **Browse** and navigate to the driver files on your local drive (refer to Figure D-3).
2. Press **Next** and the driver will be installed.

**FIGURE D-3: Browse for Driver Software**



## D.4 VERIFY COMMUNICATION

The driver is properly installed and the communication between the PC and the Hillstar Development Board is successfully established when LED 1 and LED 2 blink alternatively.



**Appendix E. Glossary**

**TABLE E-1: GestIC® GLOSSARY**

<b>Term</b>	<b>Definition</b>
AFE	Analog front end
Application Host	PC or embedded controller which controls the MGC3130
Aurea	MGC3130 PC control software with graphical user interface
Colibri Suite	Embedded DSP suite within the GestIC® Library
Deep Sleep	MGC3130 Power-Saving mode
E-field	Electrical field
Frame Electrodes	Rectangular set of four electrodes for E-field sensing
GestIC® Technology	Microchip's patented technology providing 3D free-space gesture recognition utilizing the principles of electrical near-field sensing
GestIC® Library	Includes the implementation of MGC3130 features and is delivered as a binary file preprogrammed on the MGC3130
Gesture Recognition	Microchip's stochastic HMM classifier to automatically detect and classify hand movement patterns
Gesture Set	A set of provided hand movement patterns
Hand Brick	Copper coated test block (40x40x70 mm)
HMM	Hidden Markov Model
MGC3130	Single-Zone 3D Gesture Sensing Controller
Position Tracking	GestIC® technology feature
Sabrewing	MGC3130 evaluation board
Self Wake-up	MGC3130 Power-Saving mode
Sensing Area	Area enclosed by the four frame electrodes
Sensing Space	Space above sensing area
Signal Deviation	Term for the delta of the sensor signal on approach of the hand versus non-approach
Spacer Brick	Spacer between the sensor layer and hand brick (Styrofoam block 40x40xh mm) with h= 1 / 2 / 3 / 5 / 8 / 12 cm
SPU	Signal Processing Unit
Approach Detection	GestIC® technology feature: Power-Saving mode of the MGC3130 with approach detection



# MICROCHIP

## Worldwide Sales and Service

### AMERICAS

**Corporate Office**  
2355 West Chandler Blvd.  
Chandler, AZ 85224-6199  
Tel: 480-792-7200  
Fax: 480-792-7277  
Technical Support:  
<http://www.microchip.com/support>  
Web Address:  
[www.microchip.com](http://www.microchip.com)

**Atlanta**  
Duluth, GA  
Tel: 678-957-9614  
Fax: 678-957-1455

**Boston**  
Westborough, MA  
Tel: 774-760-0087  
Fax: 774-760-0088

**Chicago**  
Itasca, IL  
Tel: 630-285-0071  
Fax: 630-285-0075

**Cleveland**  
Independence, OH  
Tel: 216-447-0464  
Fax: 216-447-0643

**Dallas**  
Addison, TX  
Tel: 972-818-7423  
Fax: 972-818-2924

**Detroit**  
Farmington Hills, MI  
Tel: 248-538-2250  
Fax: 248-538-2260

**Indianapolis**  
Noblesville, IN  
Tel: 317-773-8323  
Fax: 317-773-5453

**Los Angeles**  
Mission Viejo, CA  
Tel: 949-462-9523  
Fax: 949-462-9608

**Santa Clara**  
Santa Clara, CA  
Tel: 408-961-6444  
Fax: 408-961-6445

**Toronto**  
Mississauga, Ontario,  
Canada  
Tel: 905-673-0699  
Fax: 905-673-6509

### ASIA/PACIFIC

**Asia Pacific Office**  
Suites 3707-14, 37th Floor  
Tower 6, The Gateway  
Harbour City, Kowloon  
Hong Kong  
Tel: 852-2401-1200  
Fax: 852-2401-3431

**Australia - Sydney**  
Tel: 61-2-9868-6733  
Fax: 61-2-9868-6755

**China - Beijing**  
Tel: 86-10-8569-7000  
Fax: 86-10-8528-2104

**China - Chengdu**  
Tel: 86-28-8665-5511  
Fax: 86-28-8665-7889

**China - Chongqing**  
Tel: 86-23-8980-9588  
Fax: 86-23-8980-9500

**China - Hangzhou**  
Tel: 86-571-2819-3187  
Fax: 86-571-2819-3189

**China - Hong Kong SAR**  
Tel: 852-2943-5100  
Fax: 852-2401-3431

**China - Nanjing**  
Tel: 86-25-8473-2460  
Fax: 86-25-8473-2470

**China - Qingdao**  
Tel: 86-532-8502-7355  
Fax: 86-532-8502-7205

**China - Shanghai**  
Tel: 86-21-5407-5533  
Fax: 86-21-5407-5066

**China - Shenyang**  
Tel: 86-24-2334-2829  
Fax: 86-24-2334-2393

**China - Shenzhen**  
Tel: 86-755-8864-2200  
Fax: 86-755-8203-1760

**China - Wuhan**  
Tel: 86-27-5980-5300  
Fax: 86-27-5980-5118

**China - Xian**  
Tel: 86-29-8833-7252  
Fax: 86-29-8833-7256

**China - Xiamen**  
Tel: 86-592-2388138  
Fax: 86-592-2388130

**China - Zhuhai**  
Tel: 86-756-3210040  
Fax: 86-756-3210049

### ASIA/PACIFIC

**India - Bangalore**  
Tel: 91-80-3090-4444  
Fax: 91-80-3090-4123

**India - New Delhi**  
Tel: 91-11-4160-8631  
Fax: 91-11-4160-8632

**India - Pune**  
Tel: 91-20-3019-1500

**Japan - Osaka**  
Tel: 81-6-6152-7160  
Fax: 81-6-6152-9310

**Japan - Tokyo**  
Tel: 81-3-6880-3770  
Fax: 81-3-6880-3771

**Korea - Daegu**  
Tel: 82-53-744-4301  
Fax: 82-53-744-4302

**Korea - Seoul**  
Tel: 82-2-554-7200  
Fax: 82-2-558-5932 or  
82-2-558-5934

**Malaysia - Kuala Lumpur**  
Tel: 60-3-6201-9857  
Fax: 60-3-6201-9859

**Malaysia - Penang**  
Tel: 60-4-227-8870  
Fax: 60-4-227-4068

**Philippines - Manila**  
Tel: 63-2-634-9065  
Fax: 63-2-634-9069

**Singapore**  
Tel: 65-6334-8870  
Fax: 65-6334-8850

**Taiwan - Hsin Chu**  
Tel: 886-3-5778-366  
Fax: 886-3-5770-955

**Taiwan - Kaohsiung**  
Tel: 886-7-213-7828  
Fax: 886-7-330-9305

**Taiwan - Taipei**  
Tel: 886-2-2508-8600  
Fax: 886-2-2508-0102

**Thailand - Bangkok**  
Tel: 66-2-694-1351  
Fax: 66-2-694-1350

### EUROPE

**Austria - Wels**  
Tel: 43-7242-2244-39  
Fax: 43-7242-2244-393

**Denmark - Copenhagen**  
Tel: 45-4450-2828  
Fax: 45-4485-2829

**France - Paris**  
Tel: 33-1-69-53-63-20  
Fax: 33-1-69-30-90-79

**Germany - Munich**  
Tel: 49-89-627-144-0  
Fax: 49-89-627-144-44

**Italy - Milan**  
Tel: 39-0331-742611  
Fax: 39-0331-466781

**Netherlands - Drunen**  
Tel: 31-416-690399  
Fax: 31-416-690340

**Spain - Madrid**  
Tel: 34-91-708-08-90  
Fax: 34-91-708-08-91

**UK - Wokingham**  
Tel: 44-118-921-5869  
Fax: 44-118-921-5820

08/20/13

Компания «Life Electronics» занимается поставками электронных компонентов импортного и отечественного производства от производителей и со складов крупных дистрибьюторов Европы, Америки и Азии.

С конца 2013 года компания активно расширяет линейку поставок компонентов по направлению коаксиальный кабель, кварцевые генераторы и конденсаторы (керамические, пленочные, электролитические), за счёт заключения дистрибьюторских договоров

Мы предлагаем:

- Конкурентоспособные цены и скидки постоянным клиентам.
- Специальные условия для постоянных клиентов.
- Подбор аналогов.
- Поставку компонентов в любых объемах, удовлетворяющих вашим потребностям.
- Приемлемые сроки поставки, возможна ускоренная поставка.
- Доставку товара в любую точку России и стран СНГ.
- Комплексную поставку.
- Работу по проектам и поставку образцов.
- Формирование склада под заказчика.
- Сертификаты соответствия на поставляемую продукцию (по желанию клиента).
- Тестирование поставляемой продукции.
- Поставку компонентов, требующих военную и космическую приемку.
- Входной контроль качества.
- Наличие сертификата ISO.

В составе нашей компании организован Конструкторский отдел, призванный помогать разработчикам, и инженерам.

Конструкторский отдел помогает осуществить:

- Регистрацию проекта у производителя компонентов.
- Техническую поддержку проекта.
- Защиту от снятия компонента с производства.
- Оценку стоимости проекта по компонентам.
- Изготовление тестовой платы монтаж и пусконаладочные работы.



Тел: +7 (812) 336 43 04 (многоканальный)

Email: [org@lifeelectronics.ru](mailto:org@lifeelectronics.ru)

[www.lifeelectronics.ru](http://www.lifeelectronics.ru)