

Small-sized Class-D Speaker Amplifiers

Analog Input

Monaural Class-D Speaker Amplifier



BD5465GUL

No.10101EAT05

●Description

BD5465GUL is a monaural Class-D speaker amplifier that contained ALC function for mobile phone, portable type electronic devices etc. LC filter of speaker output is not needed, can form monaural speaker amplifier with 3 external parts. ALC, short for Automatic Level Control, is a function that automatically adjusts up to the level of suppression of distortion (clip) of output wave form during excessive input. The output limit level uses a control type which doesn't follow up power supply. The time until the limit release operation of output level is called the release time (or recovery time). This IC adopts release time (560ms/1dB Typ.) and suits the applications which play music.

Through Class-D operation, efficiency is high low power consumption that is why it's suitable for battery drive application. The current consumption during shutdown when lowered to 0.01μA(Typ.), from the shutdown to the operation time is early and at the same time pop sound is few that is why it's also suitable in repeating active and shutdown.

●Feature

- 1) Contains Digital ALC (Automatic Level Control) Function
- 2) External Parts: 3 points
- 3) Ultra slim type package: 9pin WL-CSP (1.8x1.8x0.55mmMax.)
- 4) BD5460 / 61GUL (No ALC Function, Gain Fixed Goods) Pin Compatible Specs
BD5466 / 67 / 68GUL (ALC Function, Gain Fixed Goods) Pin Compatible Specs
- 5) Maximum Gain: 12 dB (Typ.) [during ALC operation, +12~-3dB@1dB Step]
- 6) ALC limit level control type : Fixed type doesn't follow up power supply
- 7) Limit output power: 0.6W (Typ.) [VDD=3.4~5.5V, RL=8Ω]
- 8) ALC release (recovery) time: 560ms/1dB (Typ.)
- 9) Audio Analog Input (corresponds to single-end input / differential input)
- 10) Output LC filter free
- 11) Pop noise suppression circuit
- 12) Shutdown Function (use as mute at the same time) [low shutdown current = 0.01μA (Typ.)]
- 13) Contains protection circuit: output short, thermal shutdown, under voltage lockout (UVLO)

●Applications

Mobile phone, Portable audio device, PND, DSC, Note-PC etc.

●Absolute Maximum Rating(Ta=+25°C)

Parameter	Symbol	Ratings	Unit
Power Supply Voltage	VDDmax / PVDDmax	7.0	V
Power Dissipation	Pd	690*	mW
Storage Temperature Range	Tstg	-55 ~ +150	°C
SDNB Pin Input Range	V _{SDNB}	-0.3~VDD+0.3	V
IN+, IN- Pin Input Range	V _{IN}	-0.3~VDD+0.3	V

* In case Ta=+25°C or more, 5.52 mW decrease per 1°C
When mounting Rohm Typical Board 50.0mmx58.0mm (Material: Glass Epoxy)

●Operation Range

Parameter	Symbol	Ranges	Unit
Temperature	Topr	-40 ~ +85	°C
Power Supply Voltage	VDD / PVDD	+2.5 ~ +5.5	V
ALC operating Power Supply Voltage	VDD _{ALC} / PVDD _{ALC}	+3.4 ~ +5.5	V
Common Mode Input Voltage Range	V _{IC}	+0.5 ~ VDD-0.8	V

© This product is not designed for protection against radioactive rays.

● **Electrical Characteristic** (Ta=+25°C, VDD=+3.6V, Unless specified otherwise)

Parameter	Symbol	Limits			Unit	Conditions	
		Min.	Typ.	Max.			
<All Device>							
Circuit current (no signal)	I _{CC}	—	3.3	6.6	mA	IC Active, No Load V _{SDNB} =VDD	
Circuit current (shutdown)	I _{SDN}	—	0.01	2	μA	IC Shutdown V _{SDNB} =GND	
<Audio Feature>							
Limit output power	P _O	0.4	0.6	—	W	BTL, f=1kHz, R _L =8Ω THD+N≤1% , *1, *2	
Total harmonic distortion	T _{HD+N}	—	0.2	1	%	BTL, fin=1kHz, R _L =8Ω P _O =0.4W, *1	
Maximum Gain	G _{MAX}	11	12	13	dB	BTL, *1	
ALC Limit level	V _{LIM}	+6	+7	+8	dBV	BTL, *1, *2	
ALC Release level	V _{REL}	+4	+5	+6	dBV	BTL, *1, *2	
Switching frequency	f _{OSC}	150	250	350	kHz		
Start-up time	T _{ON}	0.73	1.02	1.71	msec		
Audio input resistance	R _i	40	60	80	kΩ	Gain=12dB	
<Control Terminal>							
SDNB terminal Threshold voltage	H	V _{SDNBH}	1.4	—	VDD	V	IC Active
	L	V _{SDNBL}	0	—	0.4	V	IC Shutdown
SDNB terminal Inflow Current	H	I _{SDBNH}	12	24	36	μA	V _{SDNB} =3.6V
	L	I _{SDNBL}	-5	—	5	μA	V _{SDNB} =0V

*1 Filter bandwidth for measurement: 400~30kHz, LC filter for AC measurement: L=22μH / C=1μF, BTL: Voltage between A3,C3

*2 The reference value when the device and each component is directly mounted to the Rohm typical board.

■ **Shutdown control**

Control terminal	Conditions
SDNB	
H	IC operation (active)
L	IC stop (shutdown)

■ **ALC Parameter**

ALC Parameter		
Attack Time (Typ.)	Release Time(Typ.)	Gain Switch Step (Typ.)
~1ms/1dB @ fin=100Hz ~0.5ms/1dB @ fin=1kHz ~0.05ms/1dB @ fin=10kHz	560ms/1dB @ fin=100~10kHz	±1dB

The ALC automatically adjusts the audio output level, and a function that prevents the over output to the speaker. When ALC function is working, gain switches at zero-cross point of audio output normally. If the time that audio output reaches to zero-cross point is long, gain switches at about 1msec later (attack time), at about 25msec later (release time). So, attack time and release time will change at audio input frequency. ALC parameter is fixed. ALC operation doesn't correspond to noise of impulse.

Also, ALC limit level is independent type from power supply voltage (fixed type). When power supply voltage goes down during ALC operation, there will be a risk of generating distortion at the speaker output wave.

● Measurement Circuit Diagram

<Audio Characteristics Method of Evaluation >

■ In case LC filter is not used

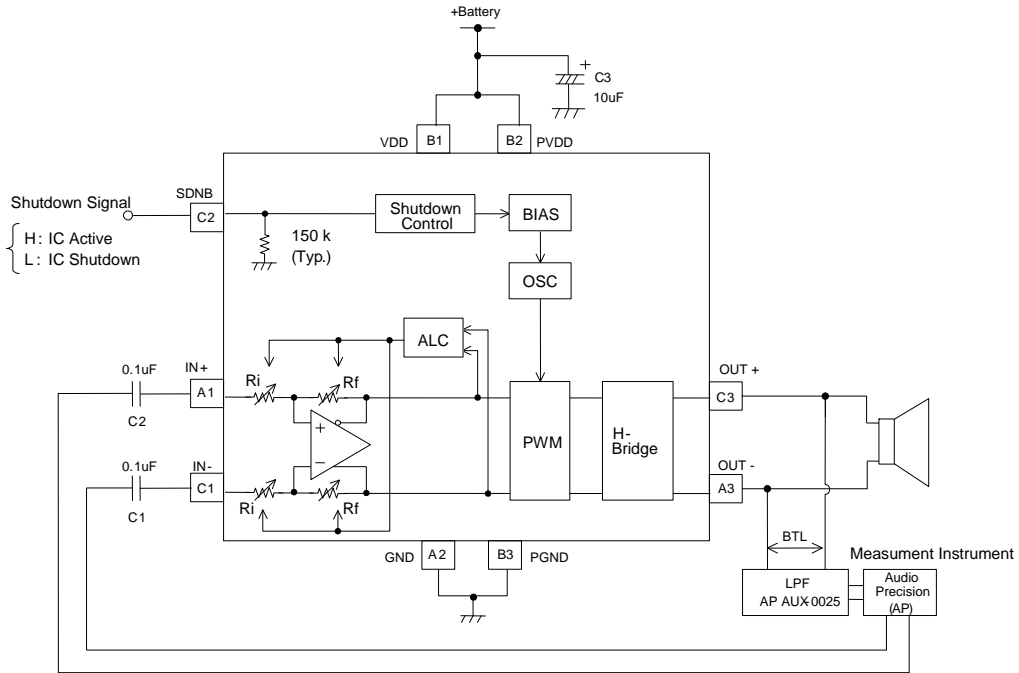

■ In case LC filter is used

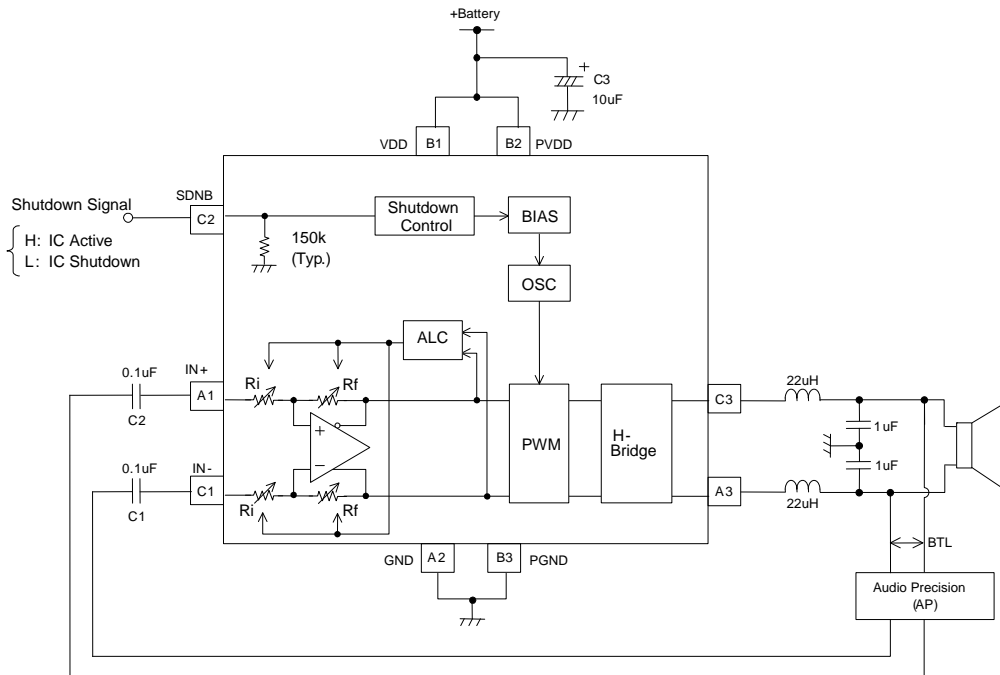

Audio characteristics can be measured to insert LC filter between output pin and speaker load, if you don't have a measurement equipment for switching amplifier, like AUX-0025, Audio Precision. Arrange the LC filter directly close to output pin.

In case of L=22µH, C=1µF, cut off frequency becomes:

$$f_c = \frac{1}{2\pi\sqrt{LC}} = \frac{1}{2\pi\sqrt{22\mu\text{H} \times 1\mu\text{F}}} \cong 34\text{kHz}$$

For Inductor L, please use huge current type.

(Reference)TDK: SLF12575T-220M4R0

●External Dimension Diagram

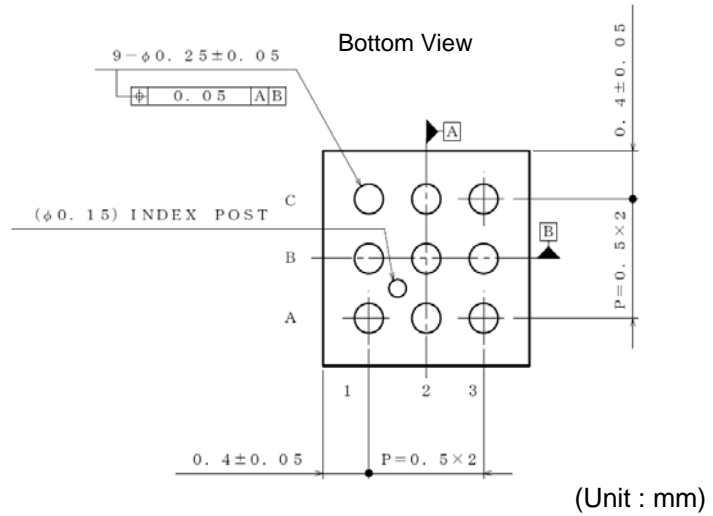
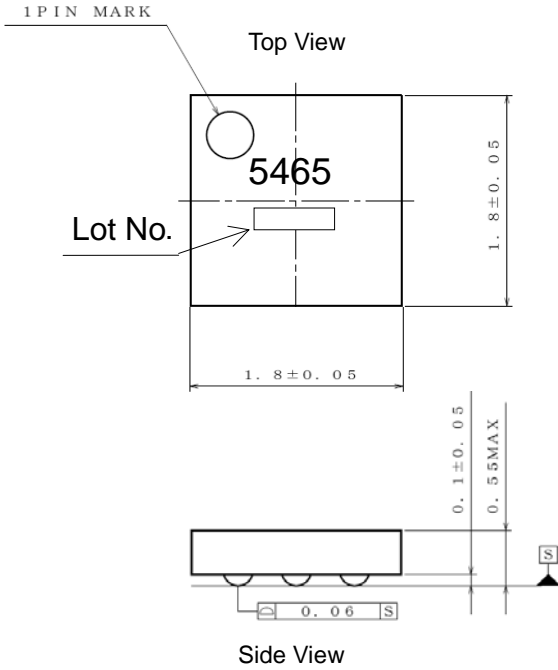

9pin WL-CSP(VCSP50L1)
[1.8 × 1.8 × 0.55mm Max, 0.5mm Pitch]

●Block Diagram

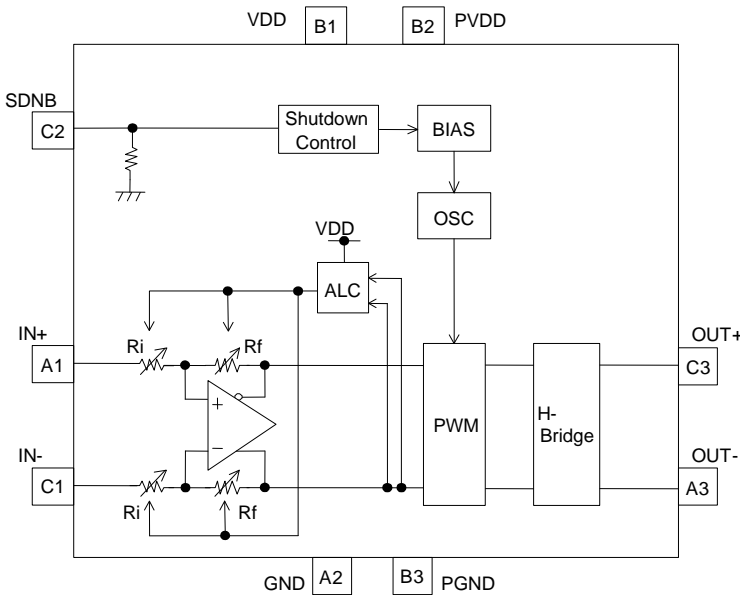

●Pin Arrangement (Bottom View)

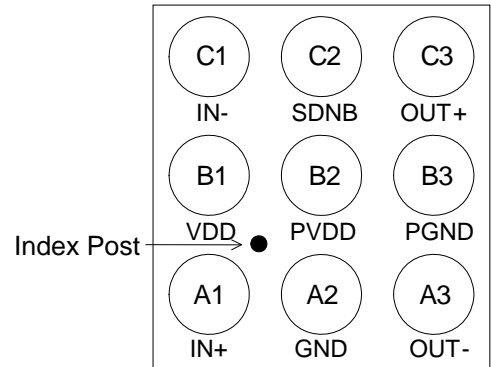

●Pin Explanation

Pin No.	Pin Name	Explanation
A1	IN+	Audio differential input + terminal
A2	GND	GND terminal (signal)
A3	OUT-	Class-D BTL output - terminal
B1	VDD	VDD terminal (signal)
B2	PVDD	VDD terminal (power)
B3	PGND	GND terminal (power)
C1	IN-	Audio differential input - terminal
C2	SDNB	Shutdown control terminal
C3	OUT+	Class-D BTL output + terminal

●Application circuit example

SHORT the power supply pin VDD (B1), PVDD (B2) at board pattern, then use singleness power supply.

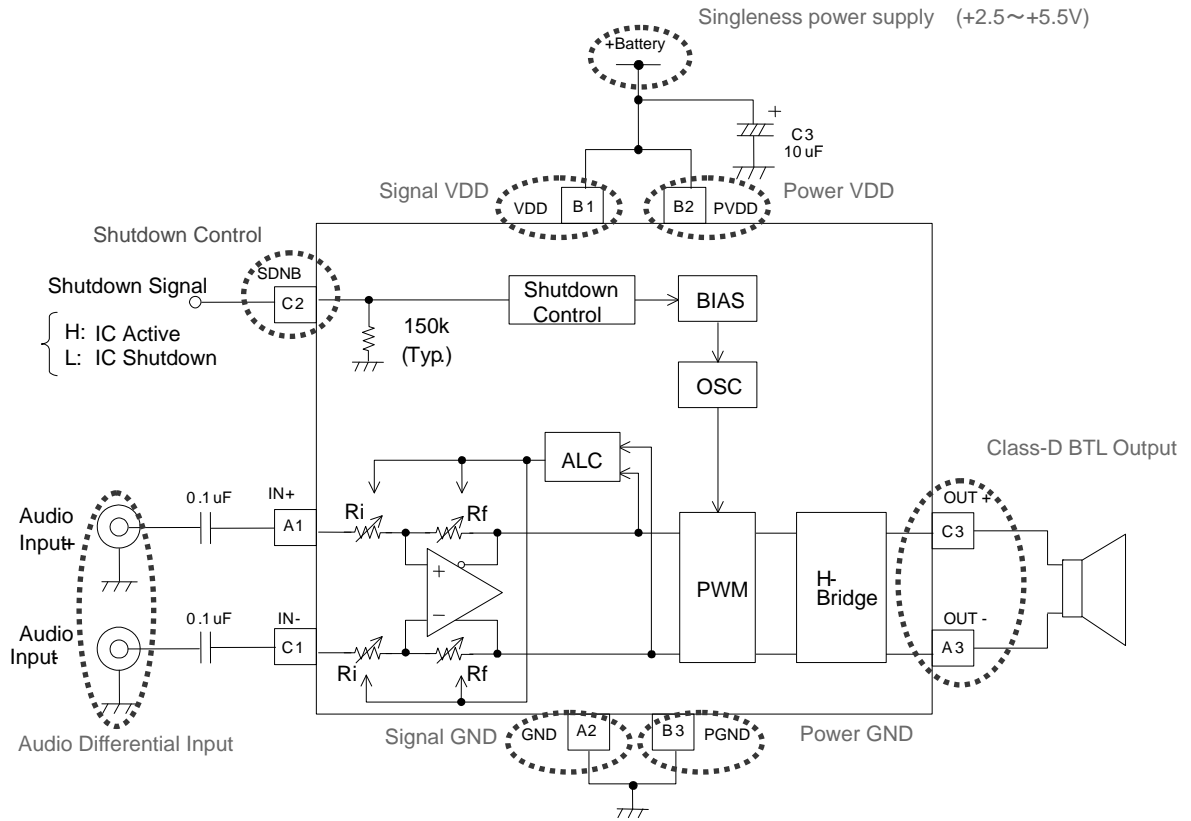

Fig1. Differential Input(With Input Coupling Capacitor)

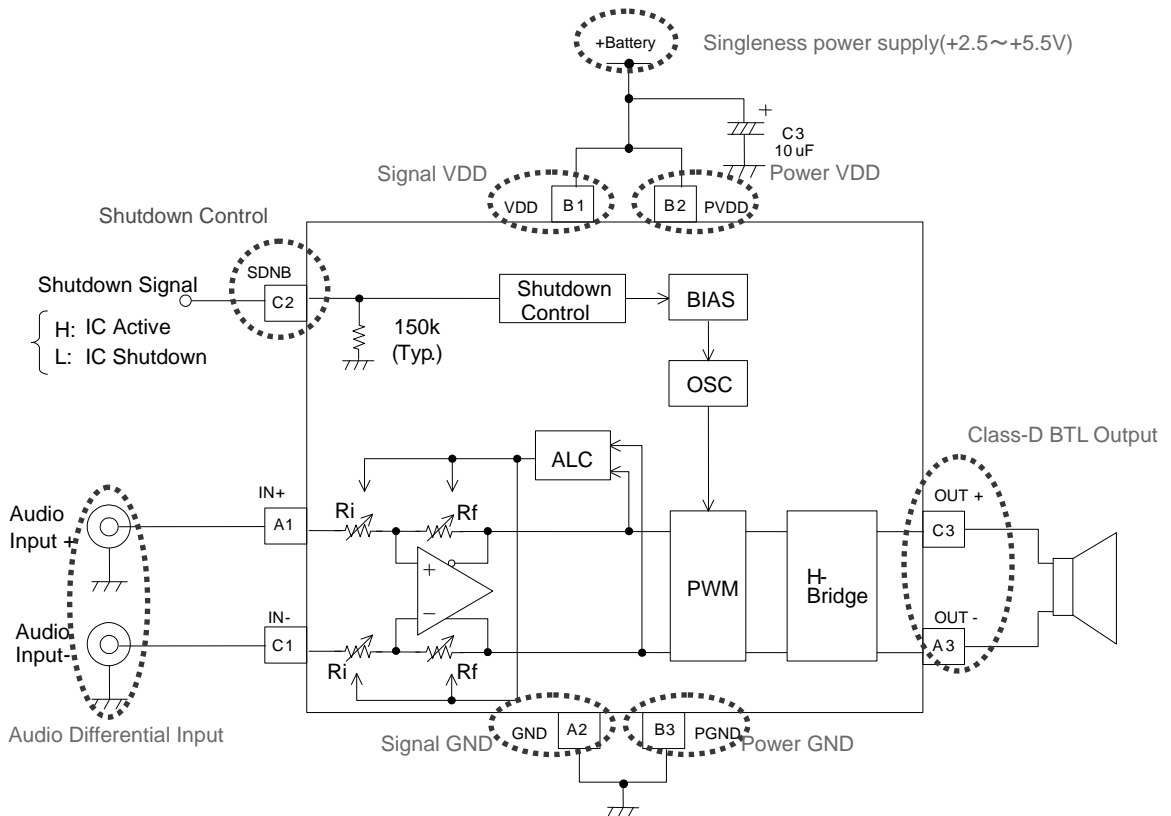

Fig2. Differential Input(Without Input Coupling Capacitor)

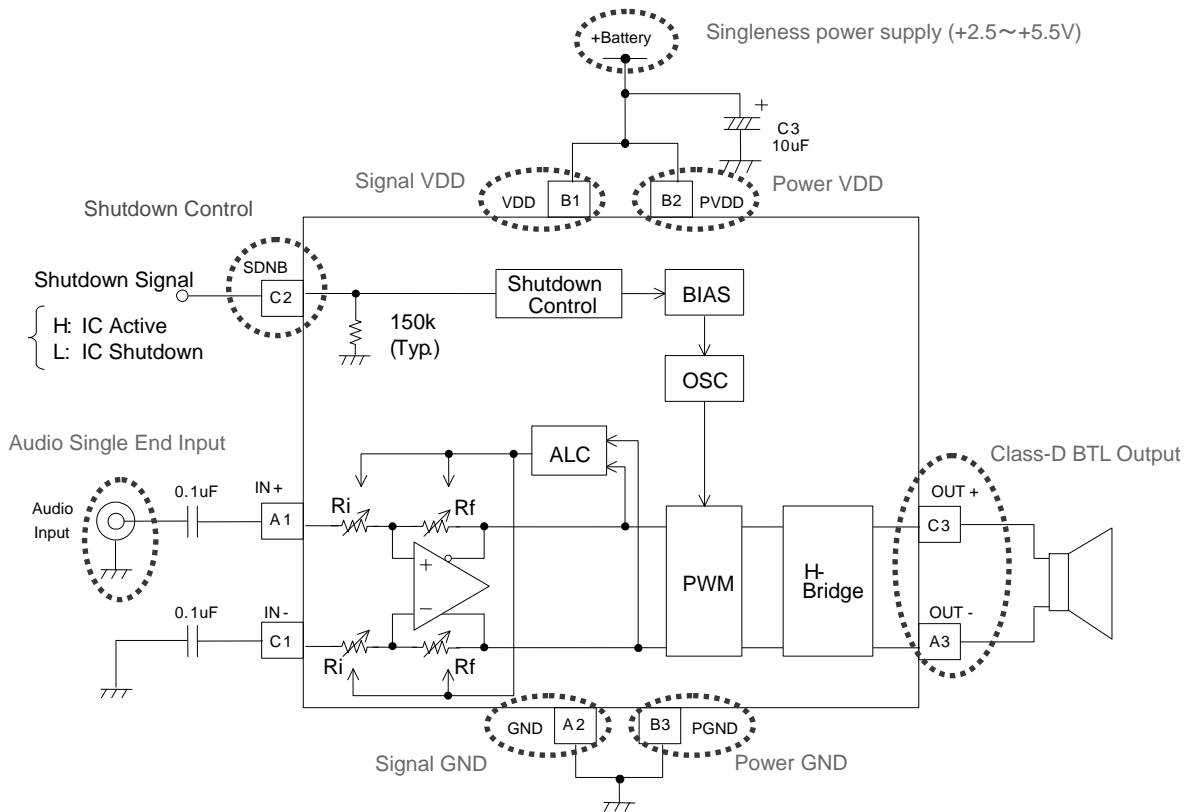

Fig3. Single end input (during IN+ input)

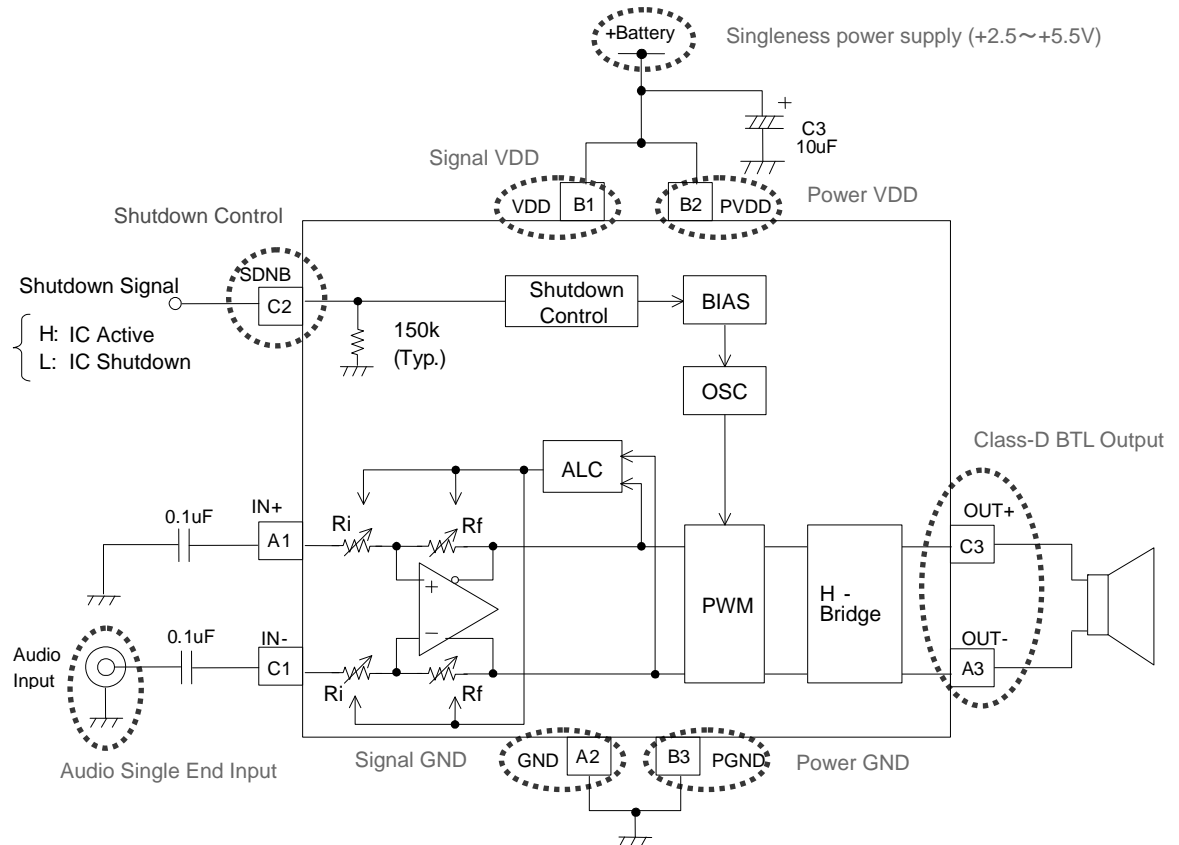



Fig4. Single end input (during IN- Input)

●About the difference of differential input and single end input

- BD5465GUL uses full differential amplifier.

BD5465GUL is a Class-D amplifier, but, in relation to Audio Input and Output, is same with the conventional Class-AB amplifier. For simplicity purposes of the diagram, the Class-D amplifier output stage is omitted in the following explanation.

About the resistor, signal  on the diagram Gives meaning to changes of gain setting by means of ALC Control.

1) Differential Input

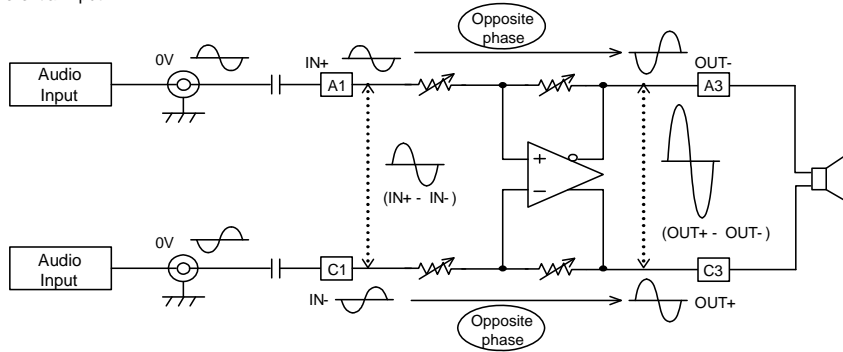

2) Single end input (during IN+ input)

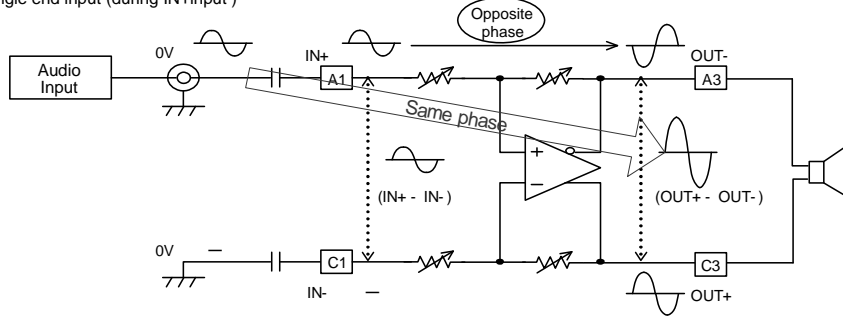

3) Single end input (during IN- input)

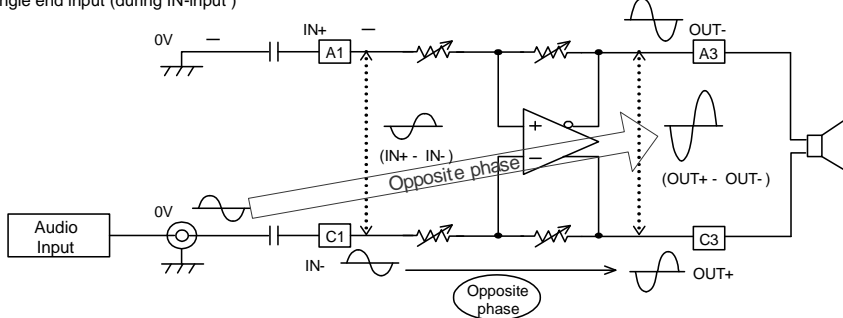

○About single end input

- Input is possible whether IN+ or IN- Pin.
Don't make input pin open, through the input coupling capacitor, please connect to GND as seen on the example above. Audio input pin should make "mute" condition, not "open" condition when you don't input any signal.
- During single end input IN+ and IN-, there is a difference with the phase relation of input and output. Because of differential amplifier, if input (IN+ - IN-), output (OUT+ - OUT-), the audio input and output phase relation will become:

Phase	IN+ Input	IN- Input
Audio Input ⇒ output (OUT+ - OUT-)	Same phase	Opposite phase

Gain calculation

【Differential Input】

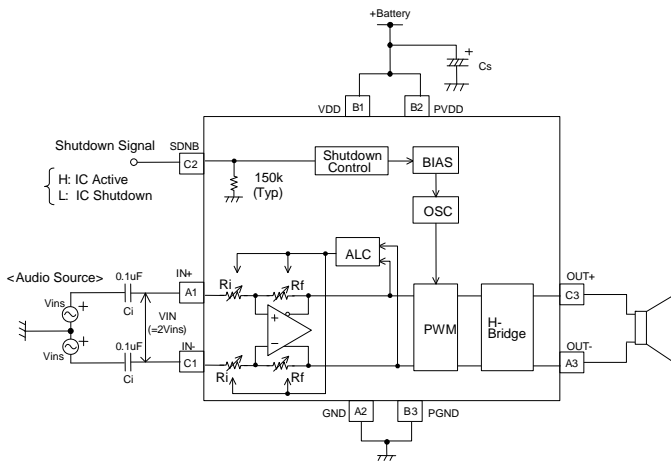

【single end input】

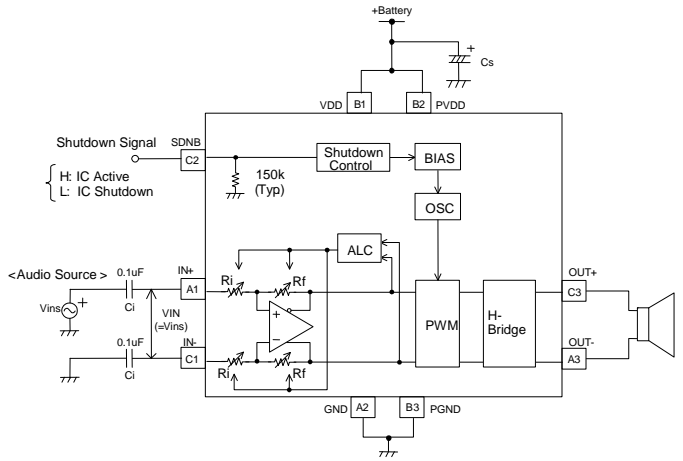

When Input Level is calculated at IC typical and audio source typical, when input coupling capacitor (Ci) value is large enough, every gain during the differential input and single end input will become:

Typical Input Level	Differential Output	Single End Output
IC	Formula①	
Audio Source	Formula②	Formula①

1. IC reference(Difference Input, Single End Input): Formula ①

VIN means the Input Voltage between IC Input Pin (IN+, IN-), VOUT means the output voltage between IC Output Pin (OUT+, OUT-). During differential input and single end input, the gain calculation formula at IC reference which includes ALC operation is written below:

$$\text{Gain} = 20 \times \log | \text{VOUT} / \text{VIN} | = +12 \sim -3 \text{ (Typ.) [dB]} \quad \dots \text{ Formula①}$$

2. Audio Source reference(Differential Input) : Formula ②

When the input level of audio source is Vins, the relation with the input voltage VIN between IC input pin is written below:

$$\text{Vins} = \text{VIN} / 2$$

During differential input, at audio source reference that includes ALC operation, gain calculation formula will become :

$$\text{Gain} = 20 \times \log | \text{VOUT} / \text{Vins} | = 20 \times \log | 2 \times \text{VOUT} / \text{VIN} | = +18 \sim +3 \text{ (Typ.) [dB]} \quad \dots \text{ Formula②}$$

3. Audio Source reference (Single End Input) : Formula ①

When the Input level of audio source is Vins, the relation with input voltage VIN between IC input pin (IN+, IN-) becomes:

$$\text{Vins} = \text{VIN}$$

During single end input, at the audio source that includes ALC operation, gain calculation formula becomes:

$$\text{Gain} = 20 \times \log | \text{VOUT} / \text{Vins} | = 20 \times \log | \text{VOUT} / \text{VIN} | = +12 \sim -3 \text{ (Typ.) [dB]} \quad \dots \text{ Formula①}$$

●Audio Input Pin External LPF connection example

■External LPF connection example

The connection example of 1st-order LPF which is formed at Resistor R_{LPF} and Capacitor C_{LPF}, to the Audio Input Pin IN+/- (A1, C1 Pin) is shown below. The cut frequency of input LPF, together with the single end input and differential input is written below:

$$f_{CLPF} = 1 / (2 \times \pi \times R_{LPF} \times C_{LPF}) \text{ [Hz]}$$

Ex) $f_{CLPF}=10\text{kHz} \Rightarrow C_{LPF}=0.01\mu\text{F}, R_{LPF}=1.59\text{k}\Omega$

1) During single end input

When LPF is connected to audio input pin at single end input setting, at start-up characteristics of audio input pin IN+/-, during start-up with unbalance (power supply ON/OFF, or shutdown ON/OFF), there is a risk that POP sound will occur so please be careful.

When no audio input, and in order to prevent output noise, please make previous IC "mute" condition, not "open" condition. Please refer at the same time to POP Sound countermeasure example.

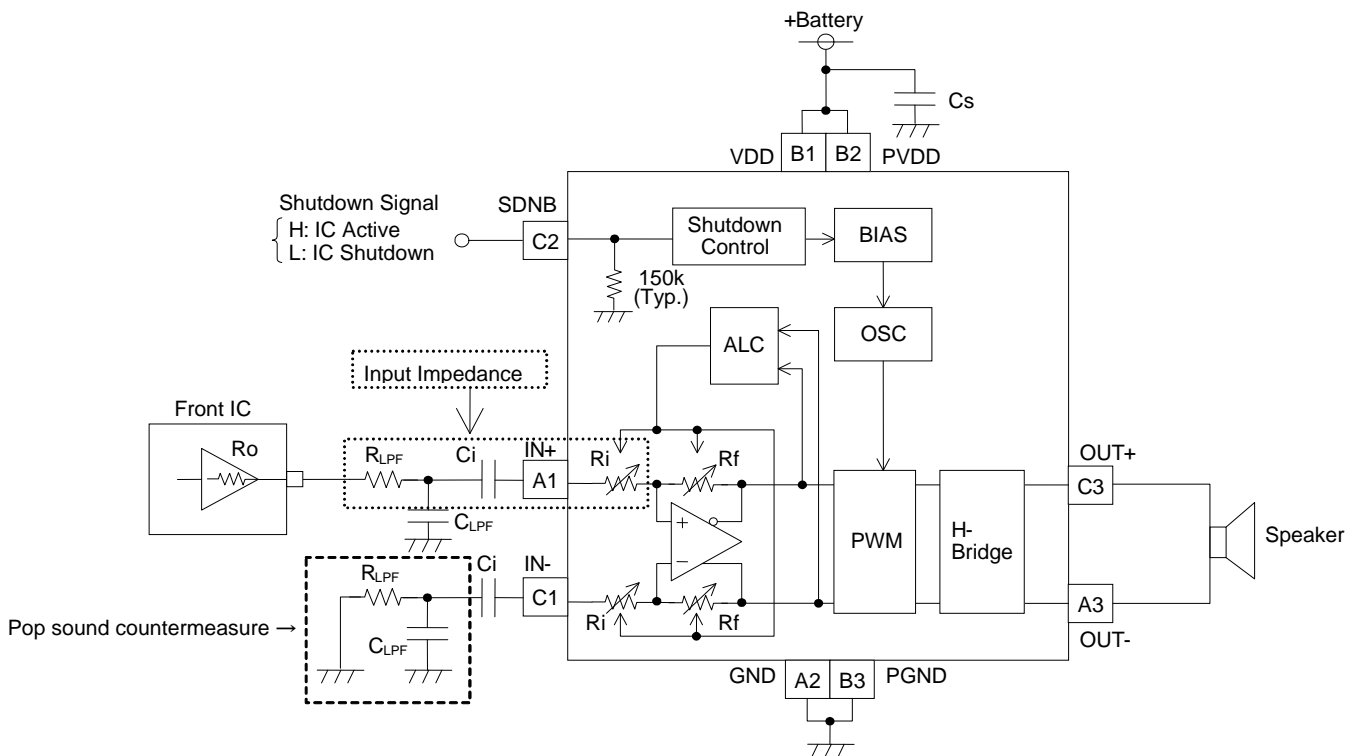

2) Differential Input

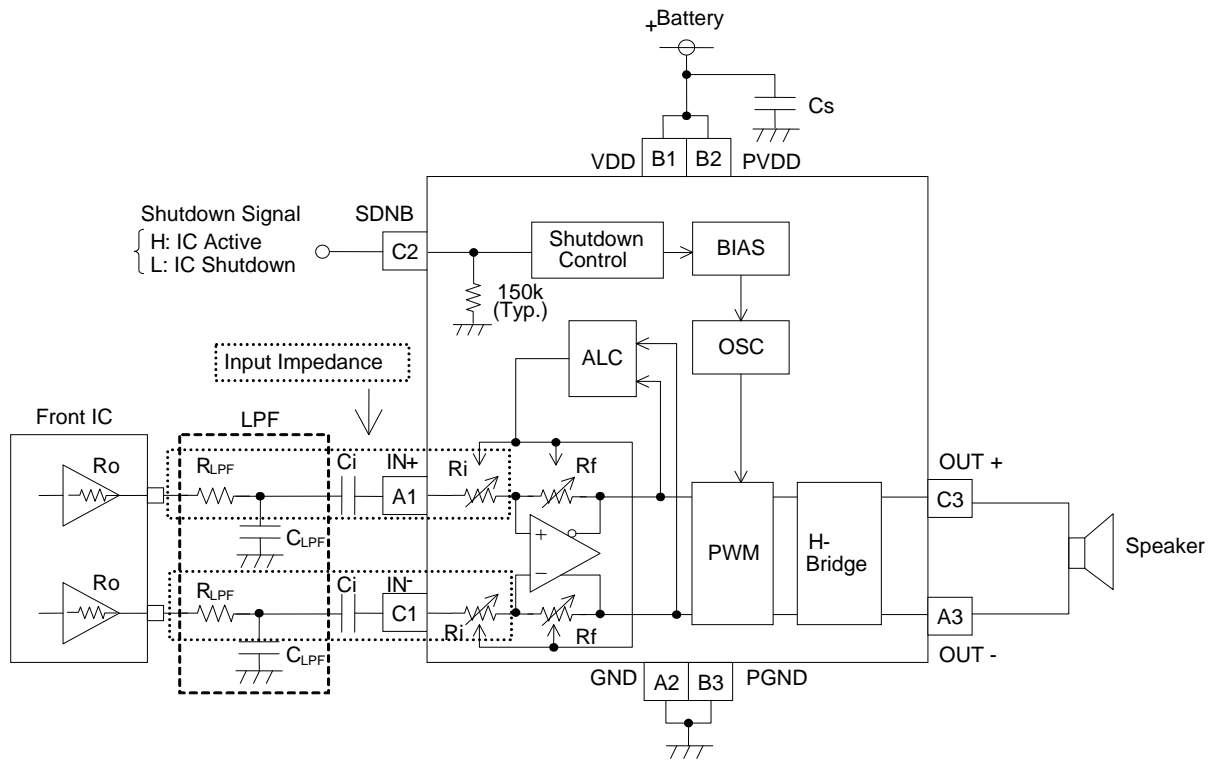

■ Caution during External LPF Setting

External LPF Resistor R_{LPF} which is composed of IC input resistor R_i , forms input impedance. The bigger the resistor value of LPF resistor R_{LPF} , the more it will decrease the gain.

When the input capacitor C_i has enough large capacity value, the relation among external LPF resistor R_{LPF} and IC input resistor R_i and Gain will become:

$$\text{Gain} = 20 \times \log | R_f / (R_i + R_{LPF}) | \quad [\text{dB}]$$

Input resistor R_i of BD5465GUL and resistor value of feedback resistor R_f will become the following below, during ALC operation, changes at $\pm 1\text{dB}$ step, and becomes 16 stages switch specs.

- #1. $R_i=60\text{k}\Omega(\text{Typ.}), R_f=240\text{k}\Omega(\text{Typ.})@ \text{Gain}=12\text{dB}$
- #2. $R_i=66\text{k}\Omega(\text{Typ.}), R_f=234\text{k}\Omega(\text{Typ.})@ \text{Gain}=11\text{dB}$
- #3. $R_i=72\text{k}\Omega(\text{Typ.}), R_f=228\text{k}\Omega(\text{Typ.})@ \text{Gain}=10\text{dB}$
- ↓
- #15. $R_i=167\text{k}\Omega(\text{Typ.}), R_f=133\text{k}\Omega(\text{Typ.})@ \text{Gain}=-2\text{dB}$
- #16. $R_i=176\text{k}\Omega(\text{Typ.}), R_f=124\text{k}\Omega(\text{Typ.})@ \text{Gain}=-3\text{dB}$

Also with the driver ability of previous IC step, after checking, constant setting of external LPF and Resistor R_{LPF} .

●Evaluation Board Circuit Diagram

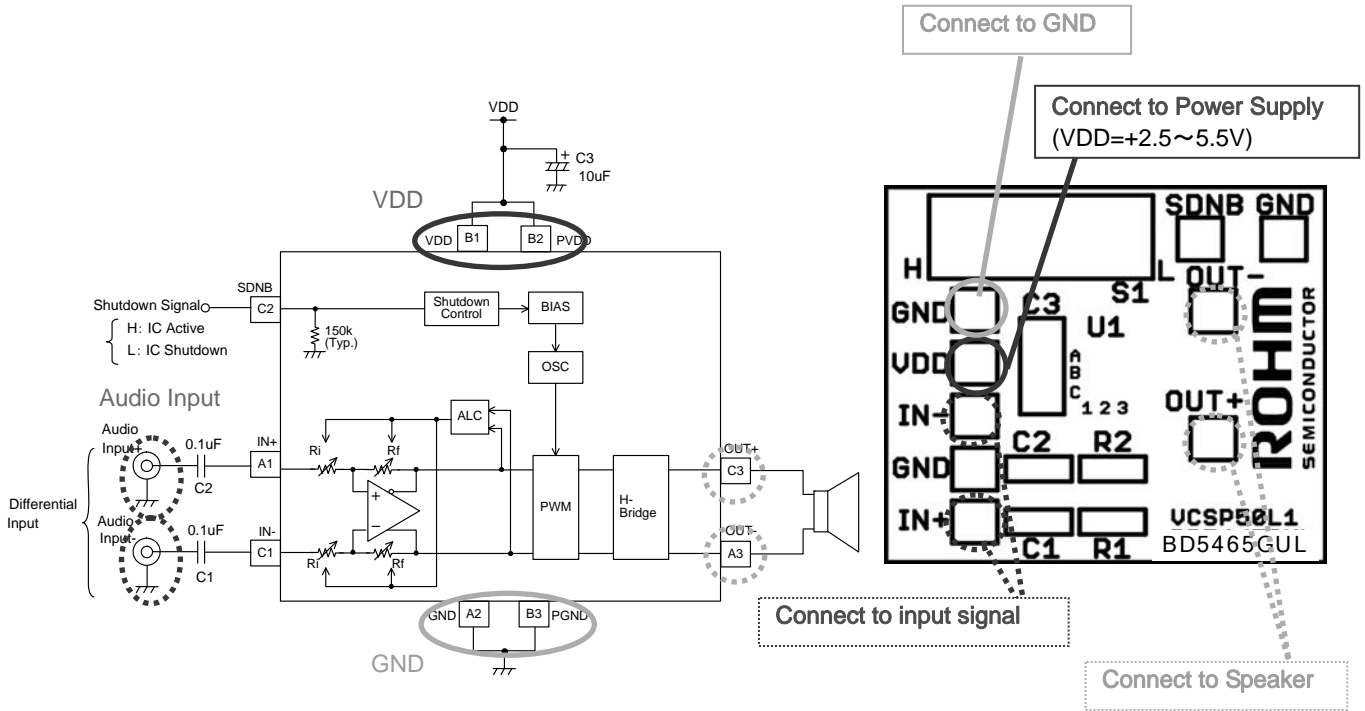

* Power Supply terminals VDD(B1), PVDD(B2) are SHORT in the board pattern and use a single power.

●Evaluation Board Parts List

Qty.	Item	Description	SMD Size	Manufacturer/ Part Number
2	C1, C2	Capacitor, 0.1μF	0603	Murata GRM188R71C104KA01D
1	C3	Capacitor, 10μF	A (3216)	ROHM TCFGA1A106M8R
1	S1	Slide Switch	4mm X 10.2mm	NKK SS-12SDP2
1	U1	IC, BD5465GUL, Mono Class-D Audio Amplifier	1.8mm X 1.8mm WLCSP Package	ROHM BD5465GUL
1	PCB1	Printed-Circuit Board, BD5465GUL EVM	—	—

●About the external part

①Input coupling capacitor (C1, C2)

Input coupling capacitor is 0.1μF.

Input impedance during maximum gain 12dB is 60kΩ (Typ.). A high-pass filter is composed by the input coupling capacitor and the input impedance.

Cut-off frequency "fc" by the formula below, through input coupling capacitor C1(=C2) and input impedance Ri.

$$f_c = \frac{1}{2\pi \times R_i \times C_1} \text{ Hz}$$

In case of Ri=60kΩ, C1(=C2)=0.1μF, cut-off frequency is about 26.5Hz

②Power Supply Decoupling Capacitor (C3)

Power Supply Decoupling Capacitor is 10μF. When the capacity value of Power Supply Decoupling Capacitor is made small, it will have an influence to the audio characteristics. When making it small, be careful with the audio characteristics at actual application. ESR (equivalent series resistor) is low enough; please use capacitor with capacity value of 1μF or more.

●Evaluation Board PCB Layer

TOP Layer Silk Pattern

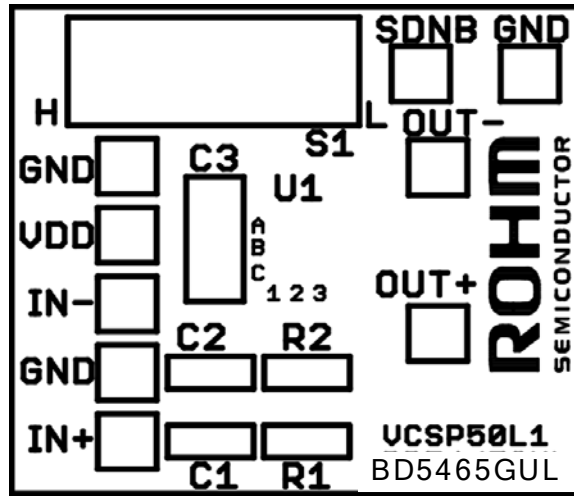

TOP Layer

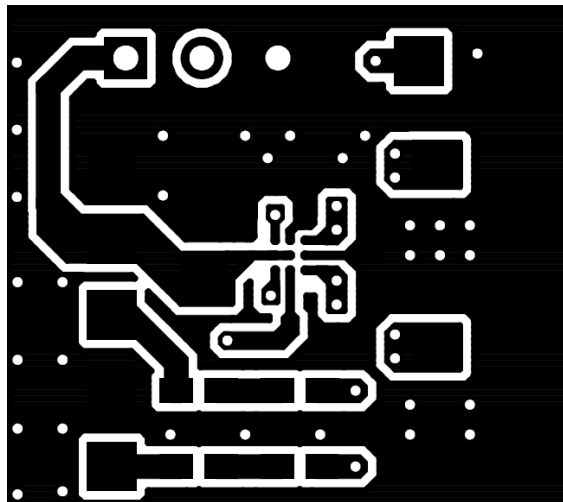

Bottom Layer

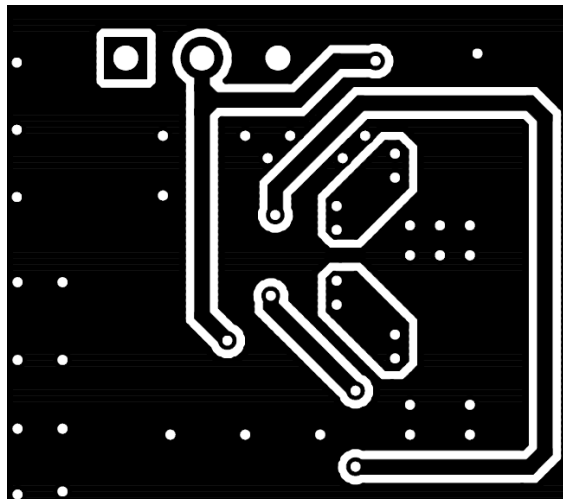

●About IC Thermal Design

The IC Characteristics has a big relation with the temperature that will be used, to exceed the maximum tolerance junction temperature, can deteriorate and destroy it. Instant destruction and long-time operation, from these 2 standpoints, there is a need to be careful with regards to IC thermal. Please be careful with the next points.

The absolute maximum rating of IC shows the maximum junction temperature ($T_{jMAX.}$) or the operation temperature range (T_{opr}), so refer to this value, use Pd-Ta characteristics (Thermal reduction ratio curve). If input signal is excessive at a state where heat radiation is not sufficient, there will be TSD(Thermal Shutdown)

For TSD, the chip temperature operates at around 180°C, releases if it's around 120°C or less. Since the aim is to prevent damage on the chip, please be careful because the long use time at the vicinity where TSD operates can deteriorate the dependency of the IC.

Thermal Reduction Ratio Curve

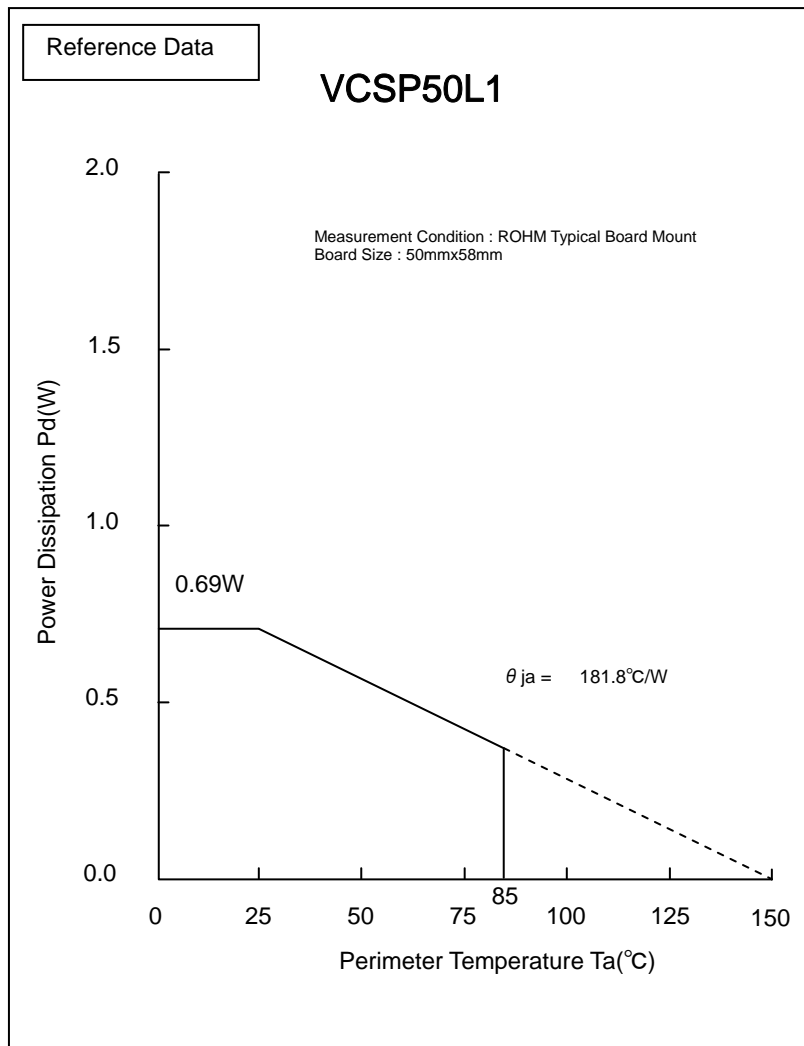

Note : This value is the real measurement, but not the guaranteed value.

The value of power dissipation changes based on the board that will be mounted.

The power dissipation of main IC during the heat dissipation design of many mounted boards, will become bigger than the value of the above graph.

● Evaluation data – Typical characteristics (1/4)

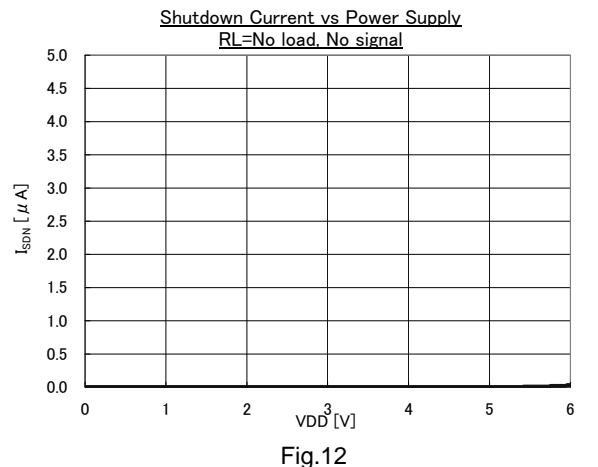
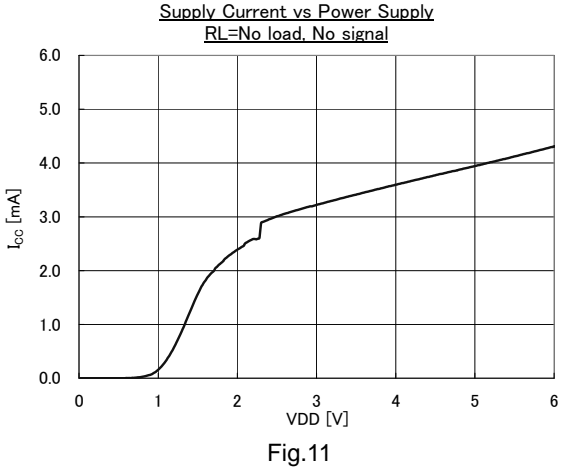
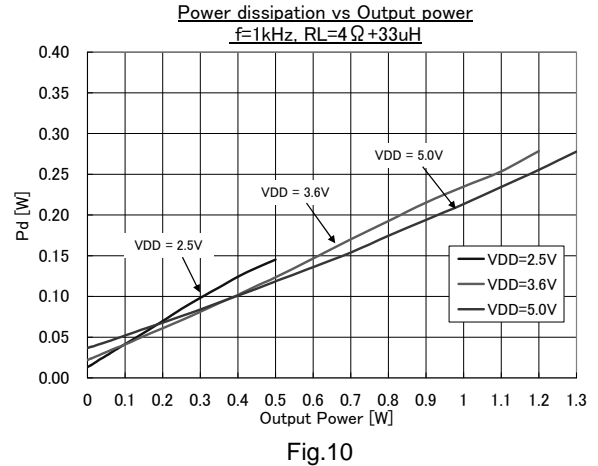
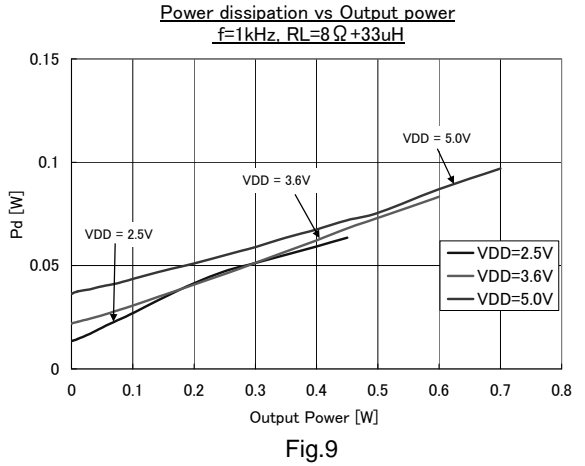
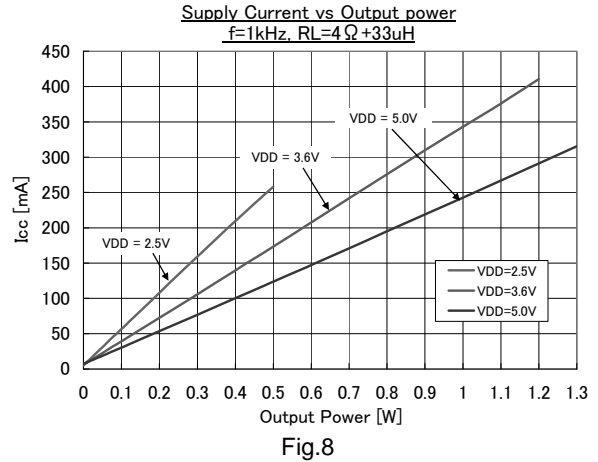
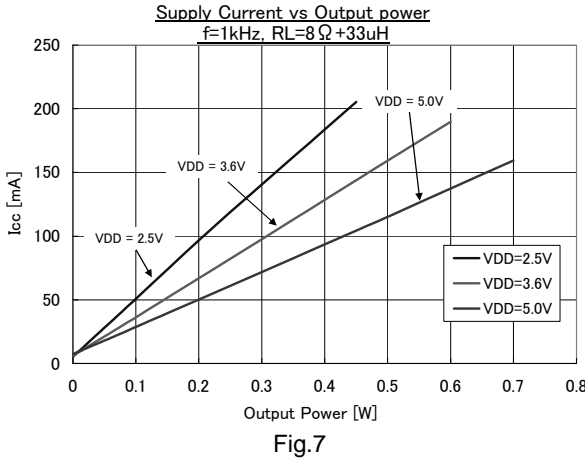
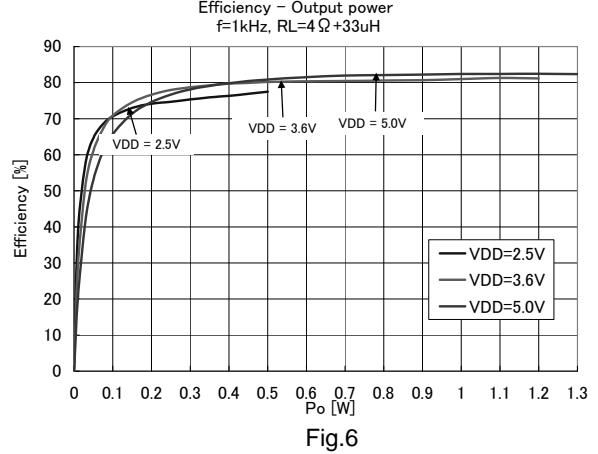
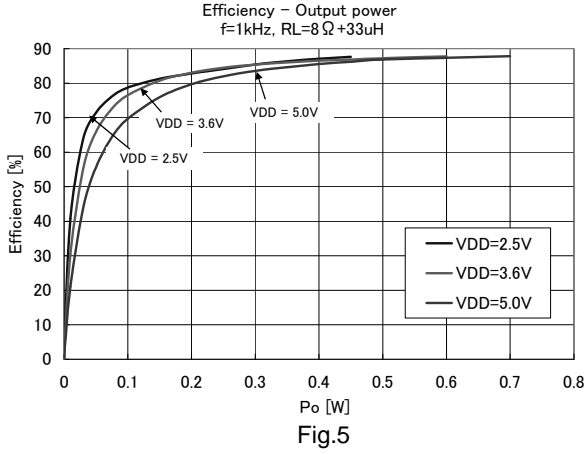

●Evaluation data – Typical characteristics (2/4)

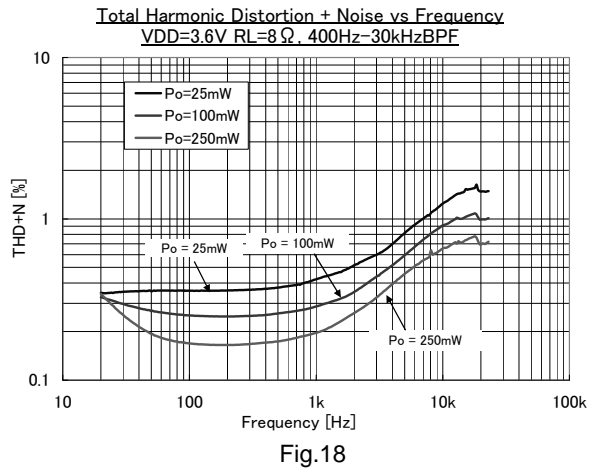
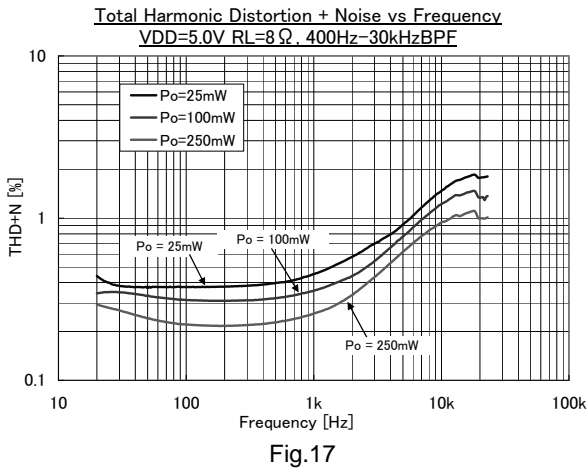
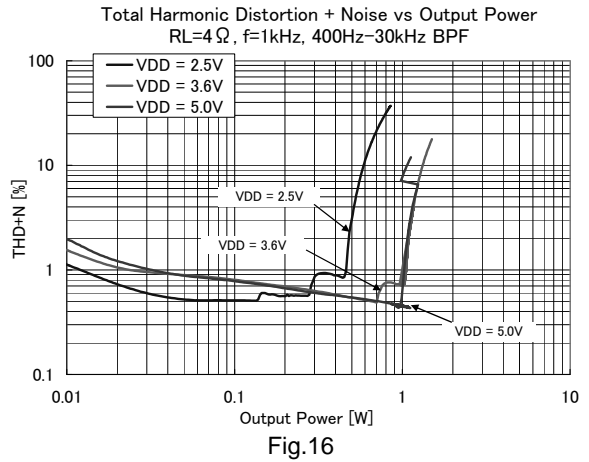
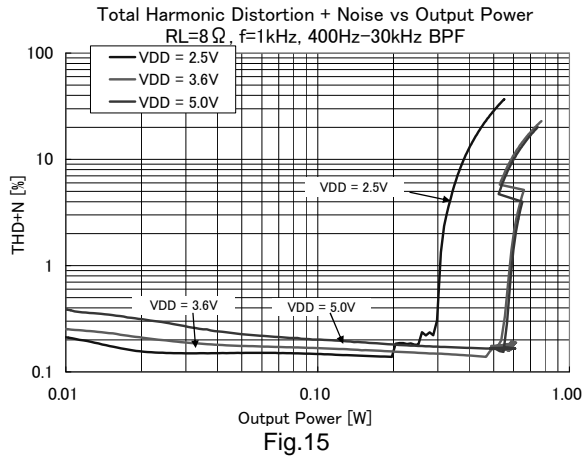
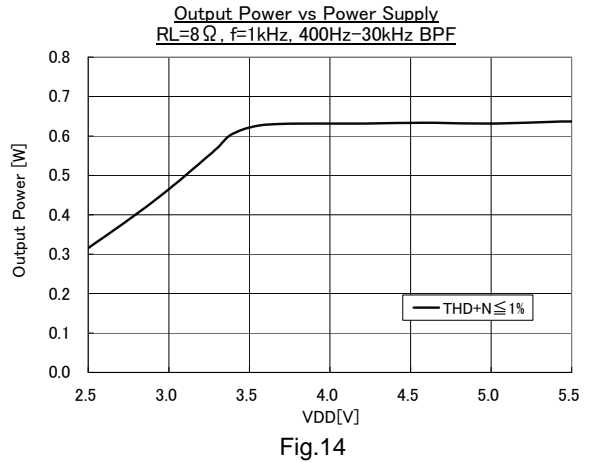
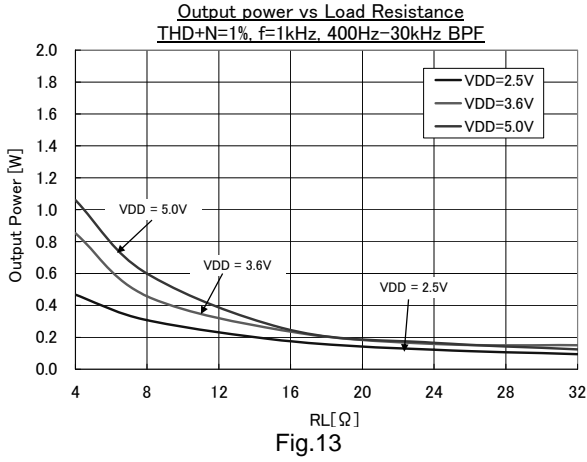

● Evaluation data – Typical characteristics (3/4)

Total Harmonic Distortion + Noise vs Frequency
 VDD=2.5V RL=8Ω, 400Hz-30kHz BPF

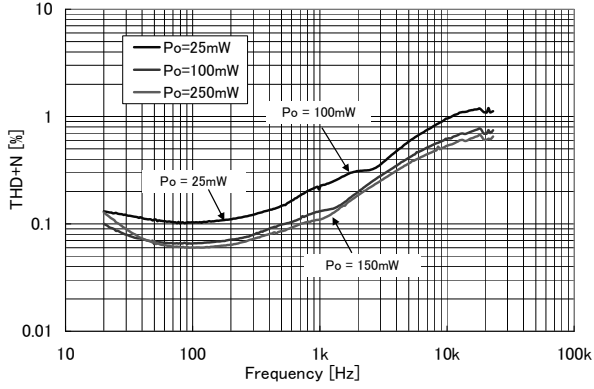

Fig.19

Total Harmonic Distortion + Noise vs Frequency
 RL=8Ω, Po=125mW, 400Hz-30kHz BPF

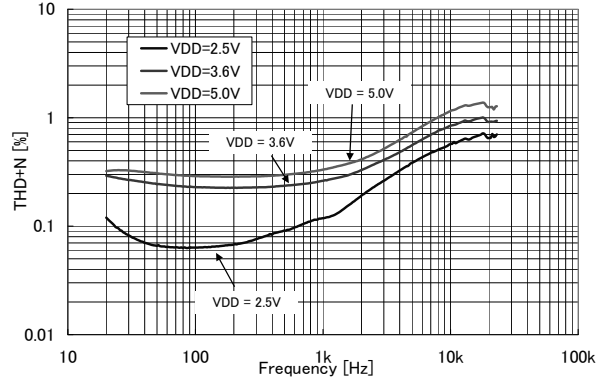

Fig.20

Gain vs Frequency
 RL=8Ω, Vin=0.5Vpp, 400Hz-30kHz BPF

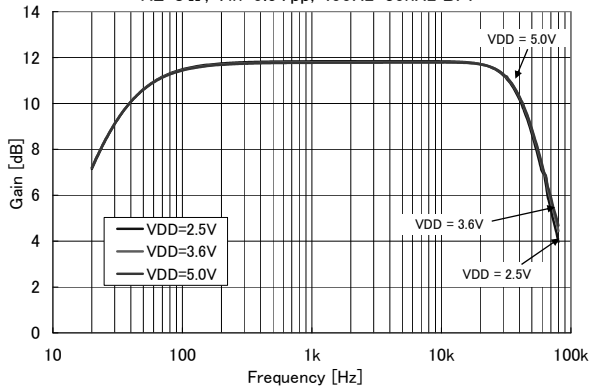

Fig.21

Gain vs Frequency
 RL=4Ω, Vin=0.5Vpp, 400Hz-30kHz BPF

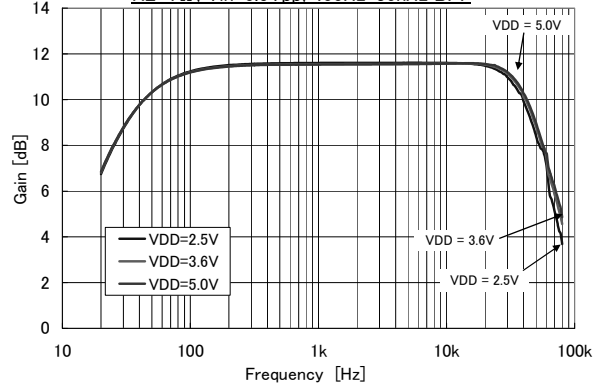

Fig.22

Output Power vs Input Level @ sweep up
 RL=8Ω, f=1kHz, 400Hz-30kHz BPF

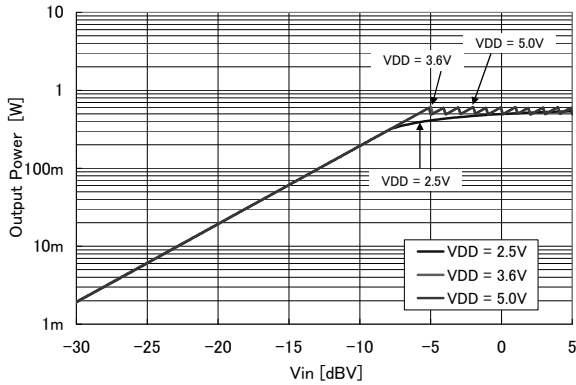

Fig.23

Total Harmonic Distortion + Noise vs Input Level @ sweep up
 RL=8Ω, f=1kHz, 400Hz-30kHz BPF

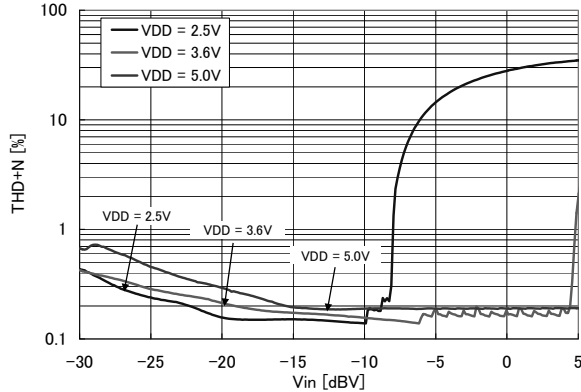

Fig.24

●Evaluation data – Typical characteristics (4/4)

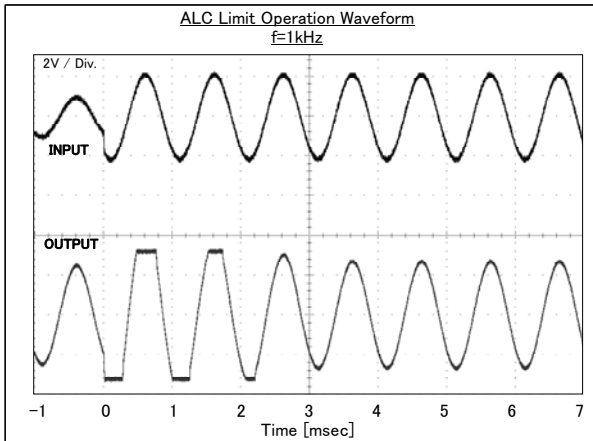

Fig.25

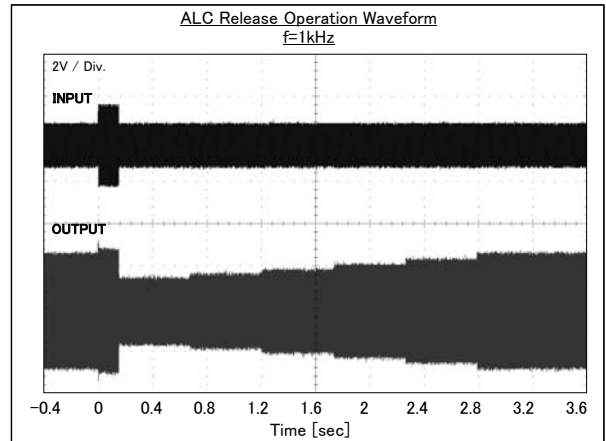

Fig.26

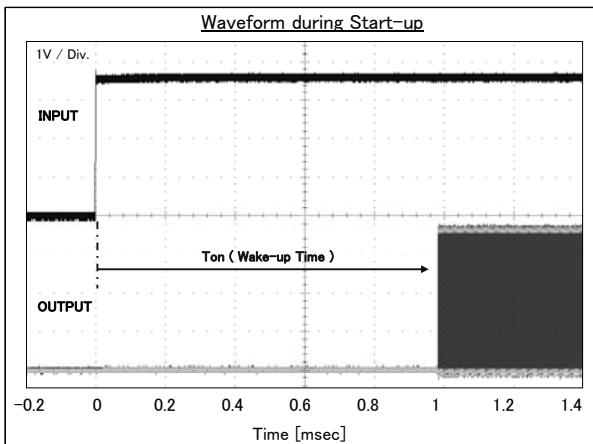

Fig.27

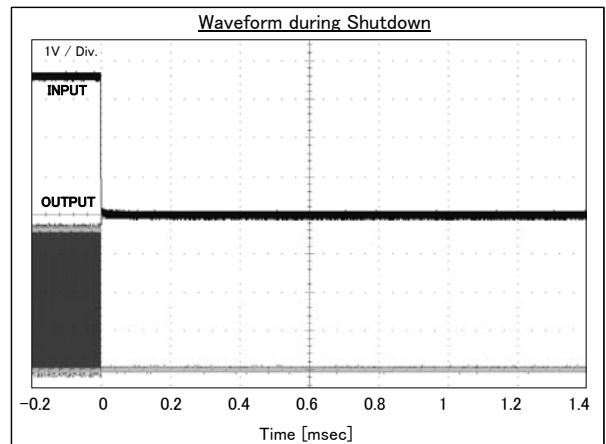
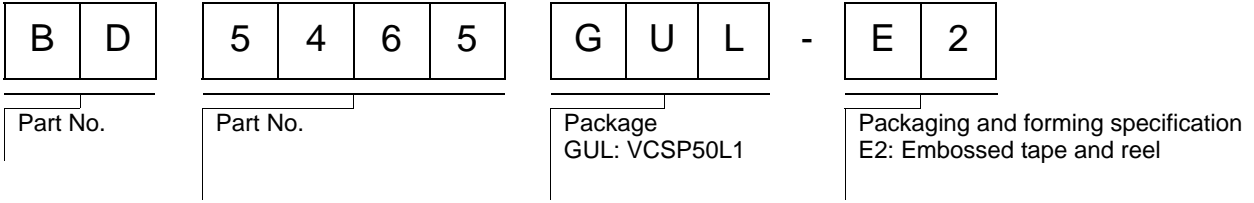

Fig.28

●Notes for use

- (1) The numerical value and the data of the mention are a design representative value and are not the one which guarantees the value.
- (2) It is convinced that it should recommend application circuit example but in case of use, we request the confirmation of the characteristic more sufficiently. When changing an external part fixed number and becoming use, it considers sprawl of the external part and our company's LSI including the transition characteristic in addition to the stillness characteristic and so on, see and fix an enough margin.
- (3) Absolute maximum ratings
This IC may be damaged if the absolute maximum ratings for the applied voltage, temperature range, or other parameters are exceeded. Therefore, avoid using a voltage or temperature that exceeds the absolute maximum ratings. If it is possible that absolute maximum ratings will be exceeded, use fuses or other physical safety measures and determine ways to avoid exceeding the IC's absolute maximum ratings.
- (4) GND terminal's potential
Try to set the minimum voltage for GND terminal's potential, regardless of the operation mode.
- (5) Shorting between pins and mounting errors
When mounting the IC chip on a board, be very careful to set the chip's orientation and position precisely. When the power is turned on, the IC may be damaged if it is not mounted correctly. The IC may also be damaged if a short occurs (due to a foreign object, etc.) between two pins, between a pin and the power supply, or between a pin and the GND.
- (6) Operation in strong magnetic fields
Note with caution that operation faults may occur when this IC operates in a strong magnetic field.
- (7) Thermal design
Ensure sufficient margins to the thermal design by taking in to account the allowable power dissipation during actual use modes, because this IC is power amplifier. When excessive signal inputs which the heat dissipation is insufficient condition, it is possible that thermal shutdown circuit is active.
- (8) Thermal shutdown circuit
This product is provided with a built-in thermal shutdown circuit. When the thermal shutdown circuit operates, the output transistors are placed under open status. The thermal shutdown circuit is primarily intended to shut down the IC avoiding thermal runaway under abnormal conditions with a chip temperature exceeding $T_{jmax}=+150^{\circ}\text{C}$, and is not intended to protect and secure an electrical appliance.
- (9) Load of the output terminal
This IC corresponds to dynamic speaker load, and doesn't correspond to the load except for dynamic speakers. When using speaker load 8Ω or less (especially 4Ω), there will be a risk of generating distortion at the speaker output wave form during ALC limit operation.
- (10) The short protection of the output terminal
This IC is built in the short protection for a protection of output transistors. When the short protection is operated, output terminal become Hi-Z condition and is stopped with latch. Once output is stopped with latch, output does not recover automatically by canceling the short-circuiting condition. The condition of stopping with latch is cancelled, when power supply or mute signal is turned off and turned on again.
- (11) Operation Range
The rated operating power supply voltage range ($V_{DD}=+2.5V\sim+5.5V$) and the rated operating temperature range ($T_a=-40^{\circ}\text{C}\sim+85^{\circ}\text{C}$) are the range by which basic circuit functions is operated. Characteristics and rated output power are not guaranteed in all power supply voltage ranges or temperature ranges.
- (12) Electrical Characteristics
Every audio characteristics list of the limit output power, total harmonic distortion, maximum gain, ALC limit level, ALC release level etc. shows the typical characteristics of the device, highly dependent to the board lay-out, parts to be used, power supply. The value when the device and each component are directly mounted to the board of Rohm.
- (13) Power Supply
Since the Power Supply Pin for signal (V_{DD}) and power supply for Power (PV_{DD}) is SHORT at internal, short the board pattern, then use a single power supply. Also, the power supply line of class-D speaker amplifier flows big peak energy. It will influence the audio characteristics based on the capacity value of power supply decoupling capacitor, arrangement. For the power supply decoupling capacitor, please arrange appropriately the low capacity ($1\mu\text{F}$ or more) of ESR (equivalent series resistor) directly near to IC Pin.
- (14) ALC (Automatic Level Control) Function
The ALC automatically adjusts the audio output level, and a function that prevents the over output to the speaker. When ALC function is working, gain switches at zero-cross point of audio output normally. If the time that audio output reaches to zero-cross point is long, gain switches at about 1msec later (attack time), at about 25msec later (release time). So, attack time and release time will change at audio input frequency. ALC parameter is fixed. ALC operation doesn't correspond to noise of impulse.
Also, ALC limit level is independent type from power supply voltage (fixed type). When power supply voltage goes down during ALC operation, there will be a risk of generating distortion at the speaker output wave.

●Ordering part number



VCSP50L1(BD5465GUL)

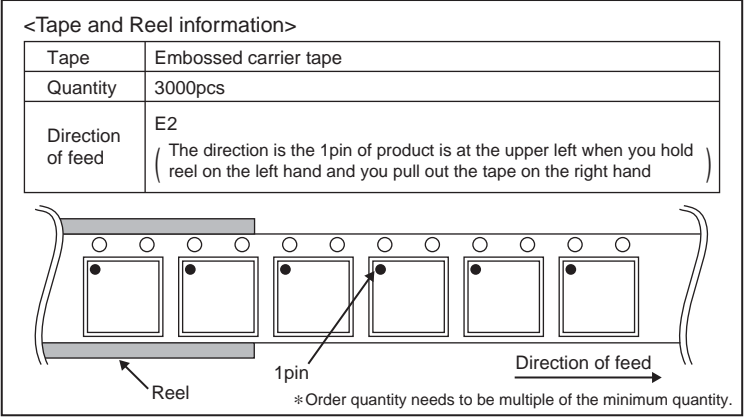
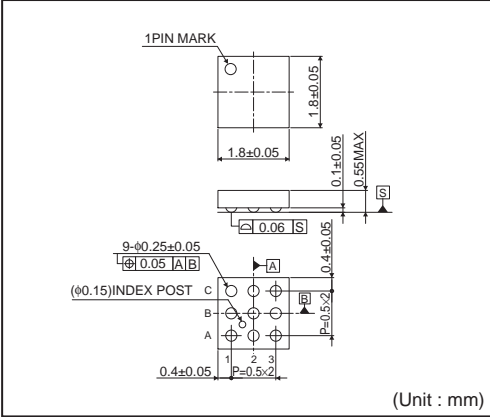

Notice

Precaution on using ROHM Products

- Our Products are designed and manufactured for application in ordinary electronic equipments (such as AV equipment, OA equipment, telecommunication equipment, home electronic appliances, amusement equipment, etc.). If you intend to use our Products in devices requiring extremely high reliability (such as medical equipment ^(Note 1), transport equipment, traffic equipment, aircraft/spacecraft, nuclear power controllers, fuel controllers, car equipment including car accessories, safety devices, etc.) and whose malfunction or failure may cause loss of human life, bodily injury or serious damage to property ("Specific Applications"), please consult with the ROHM sales representative in advance. Unless otherwise agreed in writing by ROHM in advance, ROHM shall not be in any way responsible or liable for any damages, expenses or losses incurred by you or third parties arising from the use of any ROHM's Products for Specific Applications.

(Note1) Medical Equipment Classification of the Specific Applications

JAPAN	USA	EU	CHINA
CLASS III	CLASS III	CLASS II b	CLASS III
CLASS IV		CLASS III	

- ROHM designs and manufactures its Products subject to strict quality control system. However, semiconductor products can fail or malfunction at a certain rate. Please be sure to implement, at your own responsibilities, adequate safety measures including but not limited to fail-safe design against the physical injury, damage to any property, which a failure or malfunction of our Products may cause. The following are examples of safety measures:
 - Installation of protection circuits or other protective devices to improve system safety
 - Installation of redundant circuits to reduce the impact of single or multiple circuit failure
- Our Products are designed and manufactured for use under standard conditions and not under any special or extraordinary environments or conditions, as exemplified below. Accordingly, ROHM shall not be in any way responsible or liable for any damages, expenses or losses arising from the use of any ROHM's Products under any special or extraordinary environments or conditions. If you intend to use our Products under any special or extraordinary environments or conditions (as exemplified below), your independent verification and confirmation of product performance, reliability, etc. prior to use, must be necessary:
 - Use of our Products in any types of liquid, including water, oils, chemicals, and organic solvents
 - Use of our Products outdoors or in places where the Products are exposed to direct sunlight or dust
 - Use of our Products in places where the Products are exposed to sea wind or corrosive gases, including Cl₂, H₂S, NH₃, SO₂, and NO₂
 - Use of our Products in places where the Products are exposed to static electricity or electromagnetic waves
 - Use of our Products in proximity to heat-producing components, plastic cords, or other flammable items
 - Sealing or coating our Products with resin or other coating materials
 - Use of our Products without cleaning residue of flux (even if you use no-clean type fluxes, cleaning residue of flux is recommended); or Washing our Products by using water or water-soluble cleaning agents for cleaning residue after soldering
 - Use of the Products in places subject to dew condensation
- The Products are not subject to radiation-proof design.
- Please verify and confirm characteristics of the final or mounted products in using the Products.
- In particular, if a transient load (a large amount of load applied in a short period of time, such as pulse. is applied, confirmation of performance characteristics after on-board mounting is strongly recommended. Avoid applying power exceeding normal rated power; exceeding the power rating under steady-state loading condition may negatively affect product performance and reliability.
- De-rate Power Dissipation (Pd) depending on Ambient temperature (Ta). When used in sealed area, confirm the actual ambient temperature.
- Confirm that operation temperature is within the specified range described in the product specification.
- ROHM shall not be in any way responsible or liable for failure induced under deviant condition from what is defined in this document.

Precaution for Mounting / Circuit board design

- When a highly active halogenous (chlorine, bromine, etc.) flux is used, the residue of flux may negatively affect product performance and reliability.
- In principle, the reflow soldering method must be used; if flow soldering method is preferred, please consult with the ROHM representative in advance.

For details, please refer to ROHM Mounting specification

Precautions Regarding Application Examples and External Circuits

1. If change is made to the constant of an external circuit, please allow a sufficient margin considering variations of the characteristics of the Products and external components, including transient characteristics, as well as static characteristics.
2. You agree that application notes, reference designs, and associated data and information contained in this document are presented only as guidance for Products use. Therefore, in case you use such information, you are solely responsible for it and you must exercise your own independent verification and judgment in the use of such information contained in this document. ROHM shall not be in any way responsible or liable for any damages, expenses or losses incurred by you or third parties arising from the use of such information.

Precaution for Electrostatic

This Product is electrostatic sensitive product, which may be damaged due to electrostatic discharge. Please take proper caution in your manufacturing process and storage so that voltage exceeding the Products maximum rating will not be applied to Products. Please take special care under dry condition (e.g. Grounding of human body / equipment / solder iron, isolation from charged objects, setting of Ionizer, friction prevention and temperature / humidity control).

Precaution for Storage / Transportation

1. Product performance and soldered connections may deteriorate if the Products are stored in the places where:
 - [a] the Products are exposed to sea winds or corrosive gases, including Cl₂, H₂S, NH₃, SO₂, and NO₂
 - [b] the temperature or humidity exceeds those recommended by ROHM
 - [c] the Products are exposed to direct sunshine or condensation
 - [d] the Products are exposed to high Electrostatic
2. Even under ROHM recommended storage condition, solderability of products out of recommended storage time period may be degraded. It is strongly recommended to confirm solderability before using Products of which storage time is exceeding the recommended storage time period.
3. Store / transport cartons in the correct direction, which is indicated on a carton with a symbol. Otherwise bent leads may occur due to excessive stress applied when dropping of a carton.
4. Use Products within the specified time after opening a humidity barrier bag. Baking is required before using Products of which storage time is exceeding the recommended storage time period.

Precaution for Product Label

QR code printed on ROHM Products label is for ROHM's internal use only.

Precaution for Disposition

When disposing Products please dispose them properly using an authorized industry waste company.

Precaution for Foreign Exchange and Foreign Trade act

Since our Products might fall under controlled goods prescribed by the applicable foreign exchange and foreign trade act, please consult with ROHM representative in case of export.

Precaution Regarding Intellectual Property Rights

1. All information and data including but not limited to application example contained in this document is for reference only. ROHM does not warrant that foregoing information or data will not infringe any intellectual property rights or any other rights of any third party regarding such information or data. ROHM shall not be in any way responsible or liable for infringement of any intellectual property rights or other damages arising from use of such information or data.:
2. No license, expressly or implied, is granted hereby under any intellectual property rights or other rights of ROHM or any third parties with respect to the information contained in this document.

Other Precaution

1. This document may not be reprinted or reproduced, in whole or in part, without prior written consent of ROHM.
2. The Products may not be disassembled, converted, modified, reproduced or otherwise changed without prior written consent of ROHM.
3. In no event shall you use in any way whatsoever the Products and the related technical information contained in the Products or this document for any military purposes, including but not limited to, the development of mass-destruction weapons.
4. The proper names of companies or products described in this document are trademarks or registered trademarks of ROHM, its affiliated companies or third parties.

General Precaution

1. Before you use our Products, you are requested to carefully read this document and fully understand its contents. ROHM shall not be in any way responsible or liable for failure, malfunction or accident arising from the use of any ROHM's Products against warning, caution or note contained in this document.
2. All information contained in this document is current as of the issuing date and subject to change without any prior notice. Before purchasing or using ROHM's Products, please confirm the latest information with a ROHM sales representative.
3. The information contained in this document is provided on an "as is" basis and ROHM does not warrant that all information contained in this document is accurate and/or error-free. ROHM shall not be in any way responsible or liable for any damages, expenses or losses incurred by you or third parties resulting from inaccuracy or errors of or concerning such information.

Компания «Life Electronics» занимается поставками электронных компонентов импортного и отечественного производства от производителей и со складов крупных дистрибьюторов Европы, Америки и Азии.

С конца 2013 года компания активно расширяет линейку поставок компонентов по направлению коаксиальный кабель, кварцевые генераторы и конденсаторы (керамические, пленочные, электролитические), за счёт заключения дистрибьюторских договоров

Мы предлагаем:

- Конкурентоспособные цены и скидки постоянным клиентам.
- Специальные условия для постоянных клиентов.
- Подбор аналогов.
- Поставку компонентов в любых объемах, удовлетворяющих вашим потребностям.
- Приемлемые сроки поставки, возможна ускоренная поставка.
- Доставку товара в любую точку России и стран СНГ.
- Комплексную поставку.
- Работу по проектам и поставку образцов.
- Формирование склада под заказчика.
- Сертификаты соответствия на поставляемую продукцию (по желанию клиента).
- Тестирование поставляемой продукции.
- Поставку компонентов, требующих военную и космическую приемку.
- Входной контроль качества.
- Наличие сертификата ISO.

В составе нашей компании организован Конструкторский отдел, призванный помогать разработчикам, и инженерам.

Конструкторский отдел помогает осуществить:

- Регистрацию проекта у производителя компонентов.
- Техническую поддержку проекта.
- Защиту от снятия компонента с производства.
- Оценку стоимости проекта по компонентам.
- Изготовление тестовой платы монтаж и пусконаладочные работы.



Тел: +7 (812) 336 43 04 (многоканальный)

Email: org@lifeelectronics.ru