

WLS Series

Limitless™ Single Switch Adapter



DESCRIPTION

Honeywell's Limitless™ product line uses the latest commercial off-the-shelf wireless technology and is now expanding the WLS Series to convert almost any electromechanical switch with low-energy contacts (i.e., gold) into a wireless switch. A user-supplied electromechanical switch is simply wired to the WLS Series Single Switch Adapter via the internal or external connections to then become a wireless-enabled switch for use with the Limitless™ WPMM or WDRR Series of monitors/receivers. The Limitless™ Single Switch Adapter can be used in a variety of industrial wireless limit switch applications such as reed, contact, pressure, door actuator, etc.

FEATURES

Wireless Design

- Radio (license-free and global): WPAN 802.15.4, 2.4 GHz, point-to-point
- FCC 15, IC, ACMA, ETSI, COFETEL, WPC & IDA
- Up to 305 m [1000 ft] line-of-sight communication range when used with a Limitless™ WPMM Series wireless monitor or WDRR Series receiver module (sold separately)
- Reliable, flexible, and secure wireless transmission
- Standard replaceable battery with ultra-low power consumption
- Direct or remote mount antenna options

Mechanical Design

- IP67; NEMA 1, 4, 12, 13
- 4 PIN M12 micro-change receptacle, cable grip with internal connector wiring options
- Internal battery power
- Body phosphate treated and epoxy finished with a 30 % glass-filled PBT plastic head

The Limitless™ Series is especially beneficial for remote monitoring applications where wiring or wire maintenance is not physically possible or economically feasible. Combining this greater flexibility with proven harsh-duty packaging can result in increased efficiencies and improved safety for machines, equipment, OEMs, and operators.

BENEFITS

- Allows almost any type of electromechanical switch with low-energy contacts (i.e., gold) to become “wireless”
- Enables presence/absence detection in remote parts of application/machinery, where wiring is an issue or not feasible
- Ability to reconfigure multiple switches, which easily allows for adding, subtracting or relocating of the Limitless™ WLS Single Switch Adapters
- Reduced installation/maintenance costs with no wires, conduit, strain relief, clips, connectors, connection boxes, etc.
- Eliminates issues with wire connection integrity on moving equipment
- Consumes ultra-low power to prolong battery life

POTENTIAL APPLICATIONS

- Agricultural equipment
- Construction equipment
- Door actuation (up/down) switch
- Industrial machines
- Lifts
- Machine tools
- Packaging machinery
- Wireless warehouse operations
- Wireless electromechanical switch applications (i.e., pressure switch, reed switch, basic switch and/or limit switch)

Limitless™ WLS Series

PERFORMANCE SPECIFICATIONS

Characteristic	Measure
Series name	WLS Series
Product type	Limitless™ Single Switch Adapter
Availability	Global, license-free bands
Housing material	Zinc body is phosphate treated and epoxy filled; 30 % glass-filled PBT plastic head
Housing type	WLS
Radio	WPAN 802.15.4; 2.4 GHz
Communication Agency Approvals/ Certificates*	<ul style="list-style-type: none"> • FCC 15.247: United States of America • IC RSS 210: Canada • COFETEL: Mexico • ETSI, CE mark: European countries • ACMA, C-TICK: Australia • IDA: Singapore • WPC: India
Antenna type	RP-SMA jack for direct or remote mount antenna options; omni directional standard
Signal range	Nominal 305 m [1000 ft] clear line of sight between Limitless™ switch and monitor/receiver when using 2.2 dBi integral antennas
Internal power option (battery)	3.6 Vdc Lithium Thionyl Chloride; 2/3 AA size (Est. life >1yr) Manufactured by Uniwell, part number DEV-10-0009 or Green Energy, part number ER14335M
Sealing	IP67, NEMA 1, 4, 12, 13
EMC	Latest applicable standards: EN 300 328, V1.7.1; EN 61326-1 (2006); EN 301 489-1, V1.8.1; EN 301 489-17, V2.1.1
Shock	IEC 60068-2-27; half sine, 50 g, 6 mS, 3 axis
Vibration	IEC 60068-2-6; 10-500Hz w/ 0,35 mm peak-to-peak, 58-500 Hz- 10g
Operating temperature	-40 °C to 85 °C [-40 °F to 185 °F]
Electromechanical switch	SPDT (Form C) switch with low-energy contacts (i.e., gold) capable of reliably controlling a 3.6 Vdc @ 30 mA electrical load to ensure proper operation
Electrical connections	<ul style="list-style-type: none"> • 4-pin M12 micro-connector with three-pole, single keyway female receptacle • Cable grip with internal screw connector Note: Maximum cable length 3 m [9.84 ft]

* Honeywell is continuing to add new Country Communication Agency Approvals as opportunities and requirements are established.

Limitless™ Single Switch Adapter

WLS SERIES SINGLE-SWITCH ADAPTER PRODUCT NOMENCLATURE

WLS	1	A	00	A	Q		BT1
Switch type	Gen Code	RF Code	Antenna Type Code	Country Use Code	Operating Head Code	Modification Code (BT2 & BT4 only)	Specials
WLS Series Wireless	1 Version 1	A 2.4 GHz; IEEE 802.15.4	00 No antenna; RP-SMA connector jack	A US, Canada, Mexico B All other approved countries ^{1, 2, 3}	Q See specials	Head assembled with cable grip/connector to label side 3 Head assembled with cable grip/connector to right side 4 Head assembled with cable grip/connector to left side 5 Head assembled with cable grip/connector to mounting surface	BT1 Internal battery w/ micro-connector on top of head BT2 Internal battery w/ micro-connector on side of head BT3 Internal battery w/ cable grip on top of head BT4 Internal battery w/ cable grip on side of head
			01 2.2 dBi omni w/switch mount; straight design				
			02 2.2 dBi omni w/switch mount; tilt/swivel				
			03 3.0 dBi omni w/remote adhesive mount 9.8 ft cable				
			04 5.5 dBi omni w/remote mag. mount, tilt/swivel 5 ft cable				
			05 5.5 dBi omni w/remote mag. mount, tilt/swivel 10ft cable				
			06 9.0 dBi omni w/remote mag. mount, tilt/swivel 5 ft cable				
			07 9.0 dBi omni w/remote mag. mount, tilt/swivel 10ft cable				
			08 8.0 dBi omni w/remote bkt. mount, str. design 3 ft cable				
			09 8.0 dBi omni w/remote bkt. mount, str. design 11 ft cable				
			10 2.2 dBi omni w/remote mag. mount, tilt/swivel 10 ft cable				
			11 0 dBi omni w/switch mount; straight design				

¹Use with antenna type codes 00 - 03, 05, 10, 11 only; usage also allowed in Country Code A.

²Some countries require specific communication certifications. Contact Honeywell for existing certification information.

³If Limitless devices are used on machinery that may shipped globally, use country code "B".

STANDARD LISTINGS

Part number	Description
WLS1A00AQB1	Limitless™ WLS Series Single Switch Adapter, no antenna, internal battery with M12 micro-connector on top of head for use in US, Canada, and Mexico
WLS1A00BQB1	Limitless™ WLS Series Single Switch Adapter, no antenna, internal battery with M12 micro-connector on top of head for use in all other approved countries
WLS1A02AQB1	Limitless™ WLS Series Single Switch Adapter, 2.2 dBi tilt/swivel antenna, internal battery with M12 micro-connector on top of head for use in US, Canada, and Mexico
WLS1A02BQB1	Limitless™ WLS Series Single Switch Adapter, 2.2 dBi tilt/swivel antenna, internal battery with M12 micro-connector on top of head for use in all other approved countries
WLS1A11AQB1	Limitless™ WLS Series Single Switch Adapter, 0 dBi straight antenna, internal battery with M12 micro-connector on top of head for use in US, Canada, and Mexico
WLS1A11BQB1	Limitless™ WLS Series Single Switch Adapter, 0 dBi straight antenna, internal battery with M12 micro-connector on top of head for use in all other approved countries
WLS1A00AQB3	Limitless™ WLS Series Single Switch Adapter, no antenna, internal battery with cable grip on top of head for use in US, Canada, and Mexico
WLS1A00BQB3	Limitless™ WLS Series Single Switch Adapter, no antenna, internal battery with cable grip on top of head for use in all other approved countries
WLS1A02AQB3	Limitless™ WLS Series Single Switch Adapter, 2.2 dBi tilt/swivel antenna, internal battery with cable grip on top of head for use in US, Canada, and Mexico
WLS1A02BQB3	Limitless™ WLS Series Single Switch Adapter, 2.2 dBi tilt/swivel antenna, internal battery with cable grip on top of head for use in all other approved countries
WLS1A11AQB3	Limitless™ WLS Series Single Switch Adapter, 0 dBi straight antenna, internal battery with cable grip on top of head for use in US, Canada, and Mexico
WLS1A11BQB3	Limitless™ WLS Series Single Switch Adapter, 0 dBi straight antenna, internal battery with cable grip on top of head for use in all other approved countries

Limitless™ WLS Series

WLS SERIES SINGLE-SWITCH ADAPTER DIMENSIONS

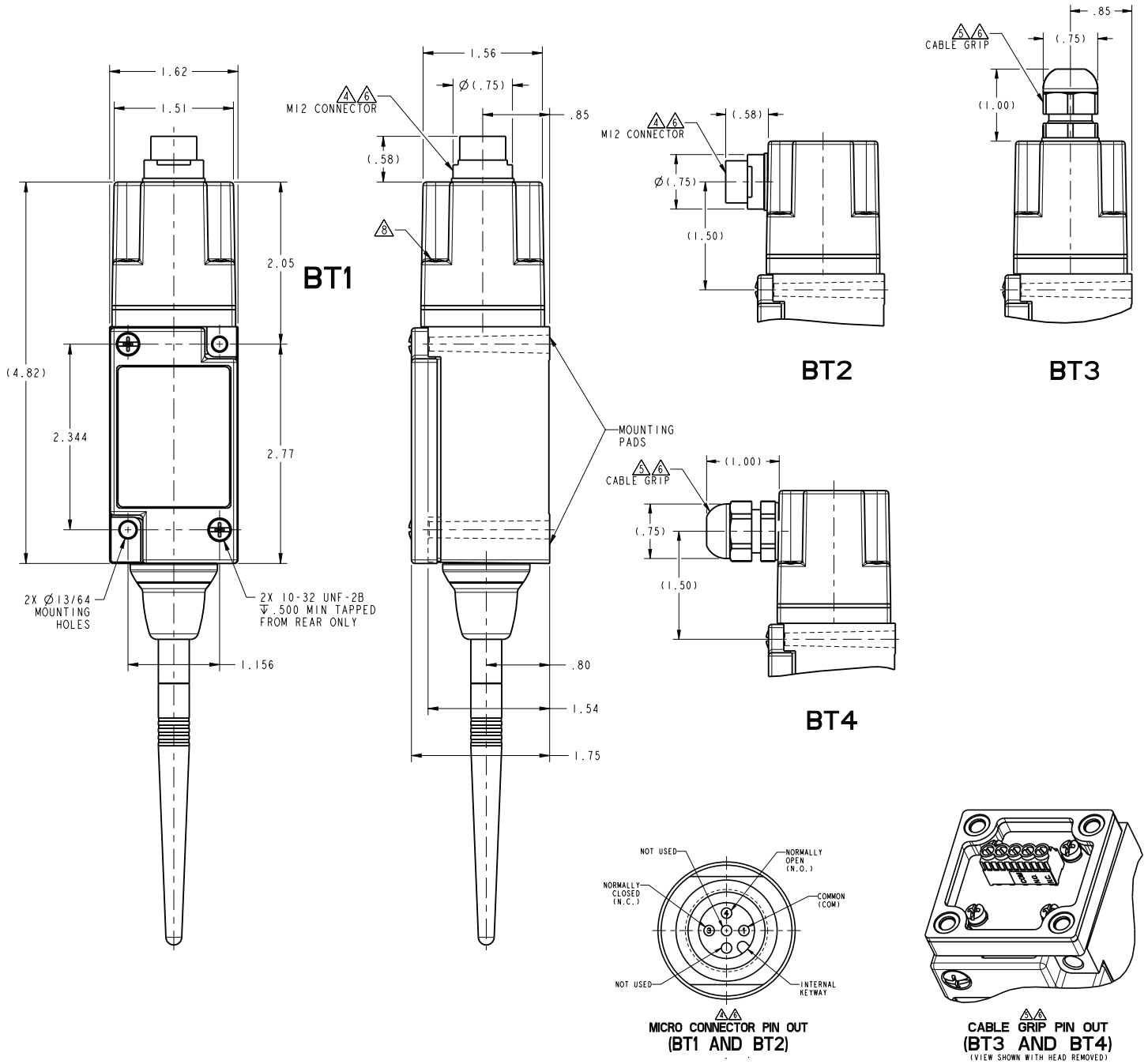

Limitless™ Single Switch Adapter

WDRR SERIES RECEIVER PRODUCT NOMENCLATURE (used in conjunction with the Limitless™ WLS switch)

WDRR	1	A	00	A	0	A
Switch type	GEN code	RF Code	Antenna type code	Country use code	Output code	Channel code
WDRR Series Din-Rail Receiver	1 Version 1	A 2.4 GHz; IEEE 802.15.4	00 No antenna; RP-SMA connector jack	A US, Canada Mexico	0 NPN/PNP selectable	A 14 channels
			01 2.2 dBi omni w/switch mount; straight design	B All other approved countries ^{1,2,3}		
			02 2.2 dBi omni w/switch mount; tilt/swivel			
			03 3.0 dBi omni w/remote adhesive mount 9.8 ft cable			
			04 5.5 dBi omni w/remote mag. mount, tilt/swivel 5 ft cable			
			05 5.5 dBi omni w/remote mag. mount, tilt/swivel 10 ft cable			
			06 9.0 dBi omni w/remote mag. mount, tilt/swivel 5 ft cable			
			07 9.0 dBi omni w/remote mag. mount, tilt/swivel 10 ft cable			
			08 8.0 dBi omni w/remote bkt. mount, str. design 3 ft cable			
			09 8.0 dBi omni w/remote bkt. mount, str. design 11 ft cable			
			10 2.2 dBi omni w/remote mag. mount, tilt/swivel 10 ft cable			

¹ Use with antenna type codes 00 - 03, 05, 10, 11 only; usage allowed in Country Code A.

² Some countries require specific communication certifications. Contact Honeywell for existing certification information.

³ If Limitless™ devices are used on machinery that may be shipped globally, use Country Code "B".

WPMM SERIES MONITOR PRODUCT NOMENCLATURE (used in conjunction with the Limitless™ WLS switch)

WPMM	1	A	00	A
Switch type	Gen Code	RF Code	Antenna type code	Country use code
WPMM Series Monitor	1 Version 1	A 2.4 GHz; IEEE 802.15.4	00 No antenna; RP-SMA connector jack	A US, Canada, Mexico
			01 2.2 dBi omni w/switch mount; straight design	B All other approved countries ^{1,2,3}
			02 2.2 dBi omni w/switch mount; tilt/swivel	
			03 3.0 dBi omni w/remote adhesive mount 9.8 ft cable	
			04 5.5 dBi omni w/remote mag. mount, tilt/swivel 5 ft cable	
			05 5.5 dBi omni w/remote mag. mount, tilt/swivel 10ft cable	
			06 9.0 dBi omni w/remote mag. mount, tilt/swivel 5 ft cable	
			07 9.0 dBi omni w/remote mag. mount, tilt/swivel 10ft cable	
			08 8.0 dBi omni w/remote bkt. mount, str. design 3 ft cable	
			09 8.0 dBi omni w/remote bkt. mount, str. design 11 ft cable	
			10 2.2 dBi omni w/remote mag. mount, tilt/swivel 10 ft cable	

¹Use with antenna type codes 00 - 03, 05, 10, 11 only; usage also allowed in Country Code A.

²Some countries require specific communication certifications. Contact Honeywell for existing certification information.

³If Limitless devices are used on machinery that may shipped globally, use country code "B".

Limitless™ WLS Series

ANTENNA OPTIONS



Antenna
Type Code
"01"

WAN01RSP
straight design,
2.2 dBi gain,
direct mount
connector



Antenna
Type Code
"02"

WAN02RSP
tilt & swivel design,
2.2 dBi gain,
direct mount
connector



Antenna Type
Code "03"

WAN03RSP
flat design,
3 dBi gain,
adhesive mount



WAN04RSP
tilt & swivel design,
5.5 dBi gain,
direct mount
connector



Antenna Type
Code "04"

**WAN05RSP &
WAMM100RSP-005**
T/S, 9 dBi gain,
magnetic mount



WAN06RNJ
straight design,
8 dBi gain,
bracket mount



Antenna
Type Code
"11"

WAN07RSP
straight design,
0 dBi gain, direct
mount connector



WAN09RSP
low-profile mobile antenna,
3.0 dBi gain, magnetic mount



WAN10RSP
straight mobile an-
tenna, 5.0 dBi gain,
magnetic mount



WAN11RSP
low-profile dome antenna,
4.0 dBi gain, through-hole screw mount



WPB1
WPMM mounting
bracket



WPR1
WPMM panel mount
retainer

Limitless™ Single Switch Adapter

ANTENNA CABLE OPTIONS

WCA200RNPRSP-002 Cable Assembly: 2 ft¹

WCA200RNPRSP-010 Cable Assembly: 10 ft¹



¹ use only with WAN06RNJ antenna and when extra cable is desired

WCA200RNJRSP-002 Cable Assembly: 2 feet length²

WCA200RNJRSP-005 Cable Assembly: 5 feet length²

WCA200RNJRSP-010 Cable Assembly: 10 feet length²

WCA200RNJRSP-015 Cable Assembly: 15 feet length²

WCA200RNJRSP-020 Cable Assembly: 20 feet length²

² Use when extra cable length is desired and allows connection from RP-SMA jack to RP-SMA plug

MOUNTING OPTIONS

Limitless™ Panel Mount Accessories

WAMM100RSP-005 Magnetic Antenna Mount: w/ 5 ft of cable³

WAMM100RSP-010 Magnetic Antenna Mount: w/ 10 ft of cable³



³ Use only with WAN01RSP, WAN02RSP, WAN04RSP, WAN05RSP, or WAN08RSP antennas

Warranty. Honeywell warrants goods of its manufacture as being free of defective materials and faulty workmanship. Honeywell's standard product warranty applies unless agreed to otherwise by Honeywell in writing; please refer to your order acknowledgement or consult your local sales office for specific warranty details. If warranted goods are returned to Honeywell during the period of coverage, Honeywell will repair or replace, at its option, without charge those items it finds defective. **The foregoing is buyer's sole remedy and is in lieu of all warranties, expressed or implied, including those of merchantability and fitness for a particular purpose. In no event shall Honeywell be liable for consequential, special, or indirect damages.**

While we provide application assistance personally, through our literature and the Honeywell web site, it is up to the customer to determine the suitability of the product in the application.

Specifications may change without notice. The information we supply is believed to be accurate and reliable as of this printing. However, we assume no responsibility for its use.

Find out more

Honeywell serves its customers through a worldwide network of sales offices, representatives and distributors. For application assistance, current specifications, pricing or name of the nearest Authorized Distributor, contact your local sales office. To learn more about Honeywell's sensing and control products, call **+1-815-235-6847/1-800-537-6945**, visit **honeywell.com/limitless**, or e-mail inquiries to **info.sc@honeywell.com**

Sensing and Control
Honeywell
1985 Douglas Drive North
Golden Valley, MN 55422 USA
honeywell.com

WARNING

MISUSE OF DOCUMENTATION

- The information presented in this datasheet is for reference only. DO NOT USE this document as product installation information.
- Complete installation, operation and maintenance information is provided in the instructions supplied with each product.

Failure to comply with these instructions could result in death or serious injury.

WARNING

PERSONAL INJURY

DO NOT USE these products as safety or emergency stop devices or in any other application where failure of the product could result in personal injury.

Failure to comply with these instructions could result in death or serious injury.

WARNING

Honeywell does not recommend using devices for critical control applications where there is, or may be, a single point of failure or where single points of failure may result in an unsafe condition. It is up to the end-user to weigh the risks and benefits to determine if the products are appropriate for the application based on security, safety and performance. Additionally, it is up to the end-user to ensure that the control strategy results in a safe operating condition if any crucial segment of the control solution fails. Honeywell customers assume full responsibility for learning and meeting the required Declaration of Conformity, Regulations, Guidelines, etc. for each country in their distribution market.

Honeywell

Компания «Life Electronics» занимается поставками электронных компонентов импортного и отечественного производства от производителей и со складов крупных дистрибьюторов Европы, Америки и Азии.

С конца 2013 года компания активно расширяет линейку поставок компонентов по направлению коаксиальный кабель, кварцевые генераторы и конденсаторы (керамические, пленочные, электролитические), за счёт заключения дистрибьюторских договоров

Мы предлагаем:

- Конкурентоспособные цены и скидки постоянным клиентам.
- Специальные условия для постоянных клиентов.
- Подбор аналогов.
- Поставку компонентов в любых объемах, удовлетворяющих вашим потребностям.
- Приемлемые сроки поставки, возможна ускоренная поставка.
- Доставку товара в любую точку России и стран СНГ.
- Комплексную поставку.
- Работу по проектам и поставку образцов.
- Формирование склада под заказчика.
- Сертификаты соответствия на поставляемую продукцию (по желанию клиента).
- Тестирование поставляемой продукции.
- Поставку компонентов, требующих военную и космическую приемку.
- Входной контроль качества.
- Наличие сертификата ISO.

В составе нашей компании организован Конструкторский отдел, призванный помогать разработчикам, и инженерам.

Конструкторский отдел помогает осуществить:

- Регистрацию проекта у производителя компонентов.
- Техническую поддержку проекта.
- Защиту от снятия компонента с производства.
- Оценку стоимости проекта по компонентам.
- Изготовление тестовой платы монтаж и пусконаладочные работы.



Тел: +7 (812) 336 43 04 (многоканальный)

Email: org@lifeelectronics.ru