

LOC	DIST	REVISIONS					
GP	00	P	LTN	DESCRIPTION	DATE	DMN	APVD
		2		PRELIMINARY	20JUN2011	AL	CW
		3		REVISED PER ECO-14-018993	3MAR2015	RG	MC

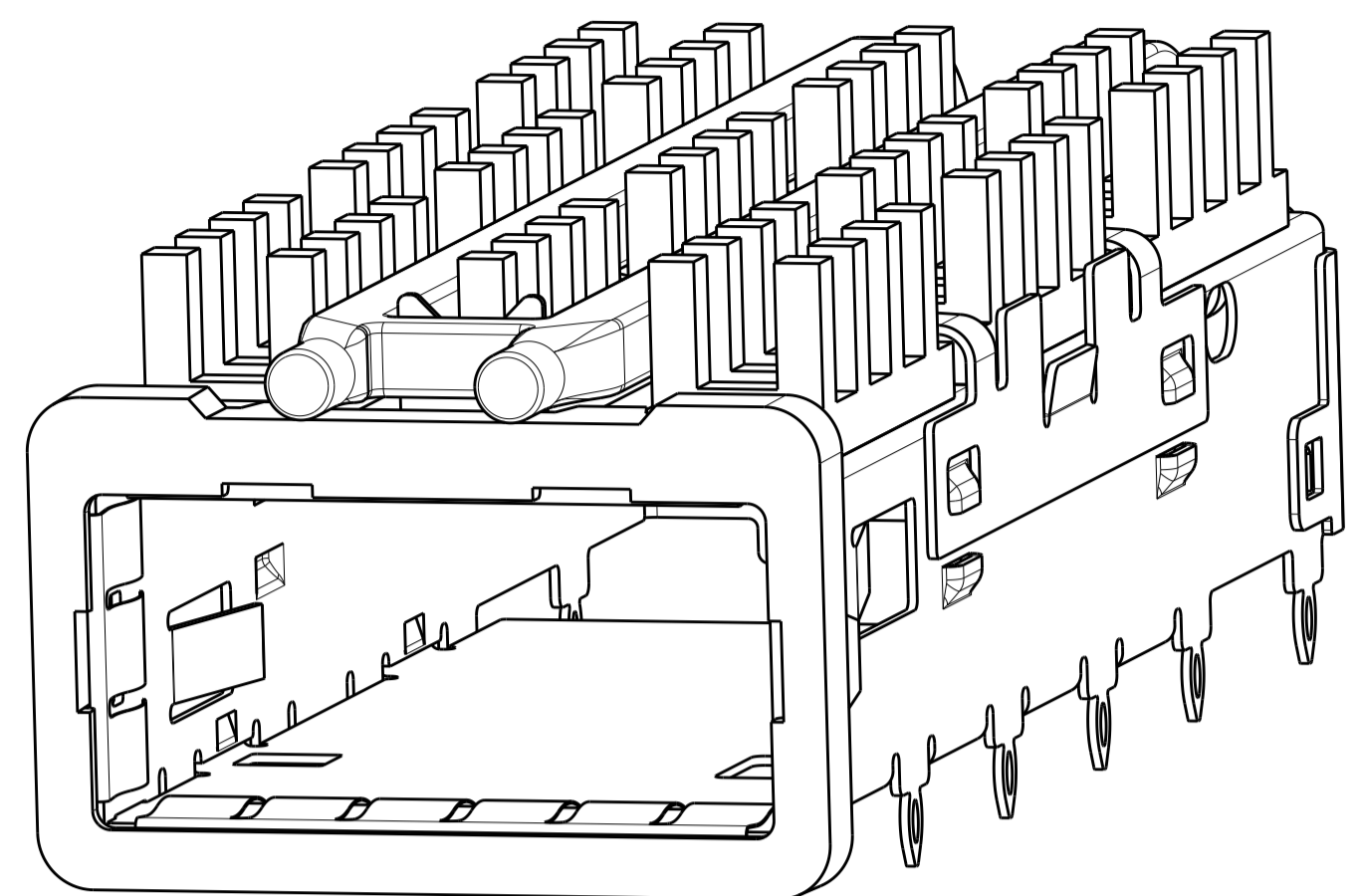

- △ CAGE MATERIAL: NICKEL SILVER, 0.25 THICK
 HEAT SINK MATERIAL: ALUMINUM
 HEAT SINK CLIP MATERIAL: STAINLESS STEEL
 EMI SPRING MATERIAL: COPPER ALLOY
 FRONT FLANGE MATERIAL: ZINC ALLOY
- △ MINIMUM PITCH DIMENSION.
- 3. MATES WITH QSFP MSA COMPATIBLE TRANSCEIVER.
- △ REFERENCE APPLICATION SPEC 114-13218 FOR RECOMMENDED DRILL HOLE DIAMETER AND PLATING THICKNESS.
- △ DATUMS AND BASIC DIMENSIONS ESTABLISHED BY CUSTOMER.
- △ DIMENSION C IS THE NOMINAL THICKNESS OF CUSTOMER SUPPLIED PC BOARD.
 SINGLE SIDED PC BOARD MINIMUM THICKNESS: 1.45
 DOUBLE SIDED PC BOARD MINIMUM THICKNESS: 2.7.
- △ HEAT SINK AND CLIP AND LIGHT PIPE SHIPPED ASSEMBLED TO CAGE ASSEMBLY CAGE ASSEMBLY MAY BE PRESSED INTO THE PCB AS SHIPPED.
- △ DATUM -A- IS TOP SURFACE OF HOST BOARD.
- △ SURFACE TRACES PERMITTED WITHIN THIS AREA EXCEPT WHERE CAGE STANDOFFS, SHOWN IN DETAIL J, CONTACT PC BOARD.
- △ DIMENSION APPLIES WITH MODULE INSTALLED IN THE CAGE.
- △ DATE CODE (YYWW) MARKED ON TOP OF CAGE AND CONCEALED BY HEAT SINK APPLIES TO CAGE ASSEMBLY ONLY.
- △ EMI SPRING FINISH: 2um MIN TIN.
 FRONT FLANGE FINISH: 3um MIN TIN OVER 1.27um MIN NICKEL OVER 5.08um MIN COPPER.
 HEAT SINK FINISH: 0.076um MIN NICKEL PLATING.
- 13. PRODUCT HAS NOT COMPLETED QUALIFICATION TESTING.

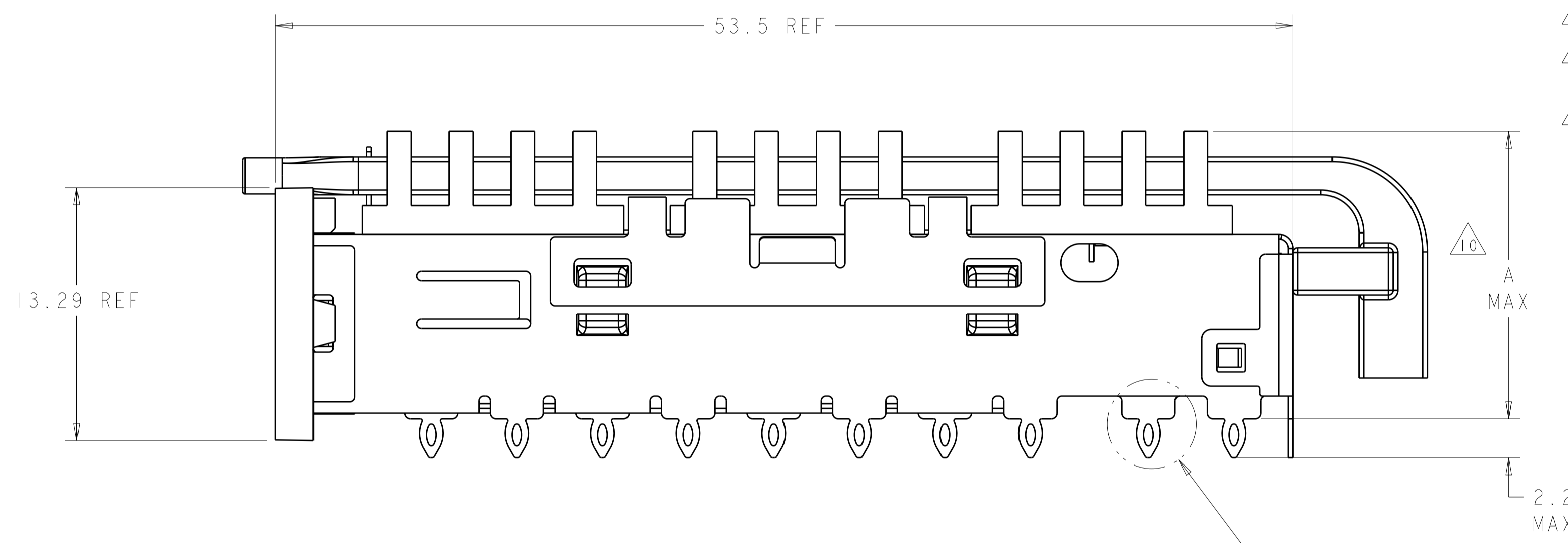
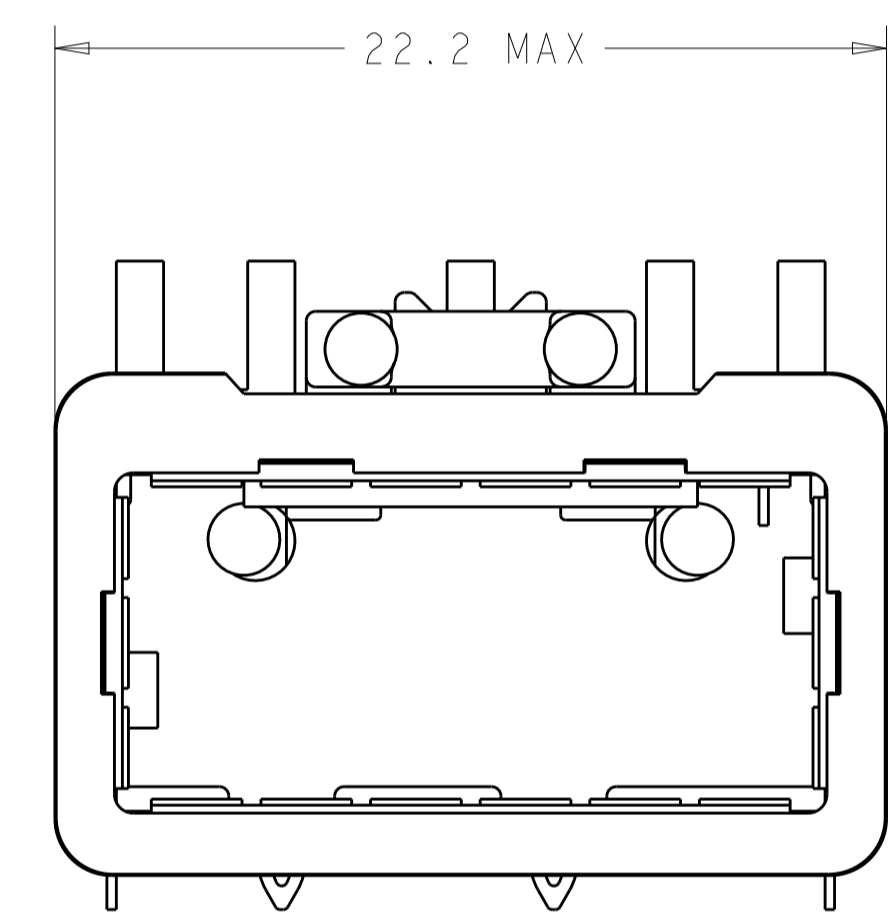

2170112-2 AS SHOWN

SEE DETAIL J

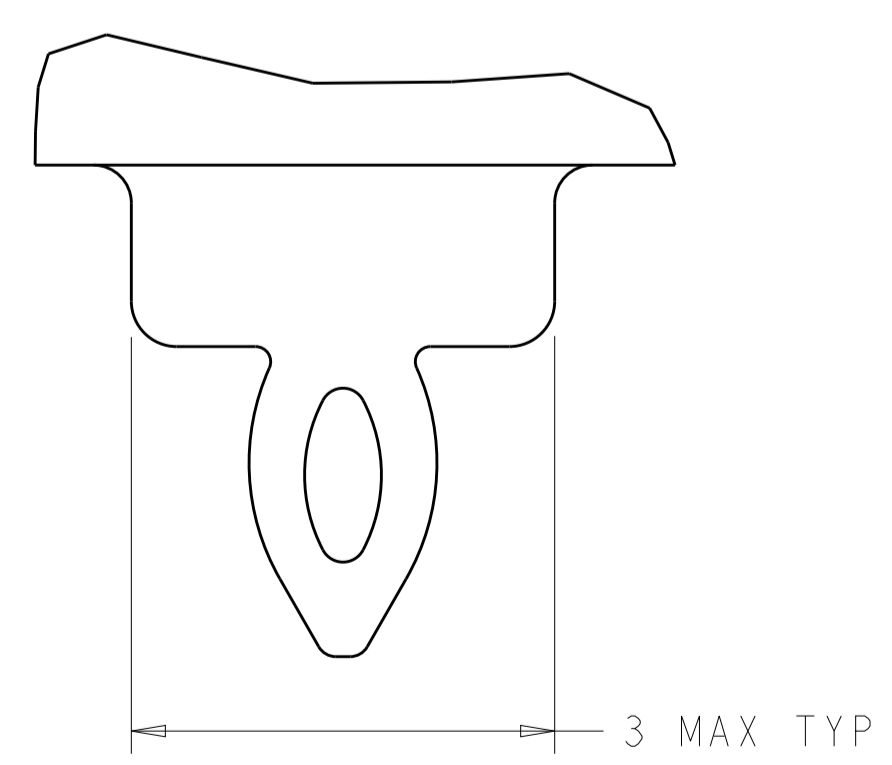

DETAIL J △
 SCALE 20:1

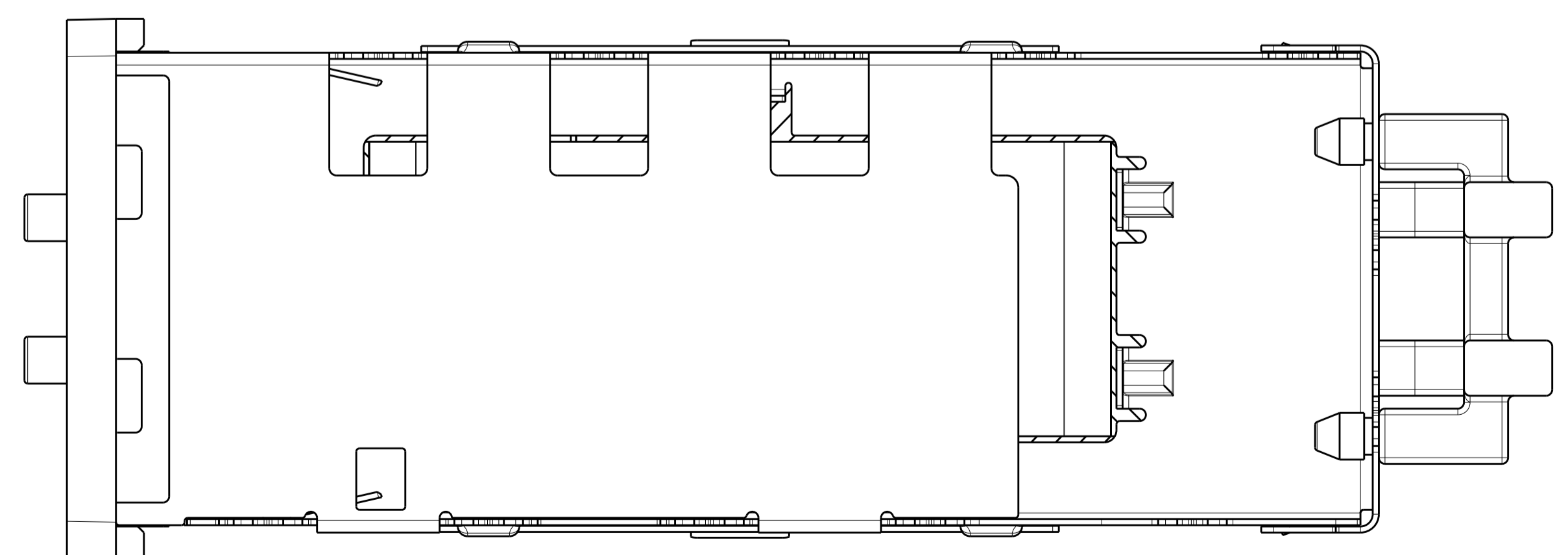

23.0	NETWORKING HEAT SINK	2170112-3
16.0	SAN HEAT SINK (SHOWN)	2170112-2
13.7	PCI HEAT SINK	2170112-1
A	DESCRIPTION	PART NUMBER

THIS DRAWING IS A CONTROLLED DOCUMENT.		DMN: 27MAY2011	STE TE Connectivity	
DIMENSIONS: mm		CHK: 27MAY2011		
TOLERANCES UNLESS OTHERWISE SPECIFIED:		TX: 27MAY2011	NAME: 1X1 CAGE ASSEMBLY, BEHIND BEZEL WITH HEAT SINK AND DUAL LIGHT PIPE QSFP	
0 PLC ±0.5	1 PLC ±0.13	APVD: CW	PRODUCT SPEC: 108-2286	
2 PLC ±0.013	3 PLC ±0.001	CW	APPLICATION SPEC: 114-13218	
4 PLC ±0.001	ANGLES ±		SIZE: CAGE CODE DRAWING NO: A100779C=2170112	
MATERIAL: △		FINISH: △2	RESTRICTED TO: -	
Customer Drawing		WEIGHT: -	SCALE: 5:1 SHEET 1 OF 5 REV 3	

LOC	DIST	REVISIONS			
P	LTN	DESCRIPTION	DATE	DWN	APVD
GP	00	SEE SHEET 1	-	-	-

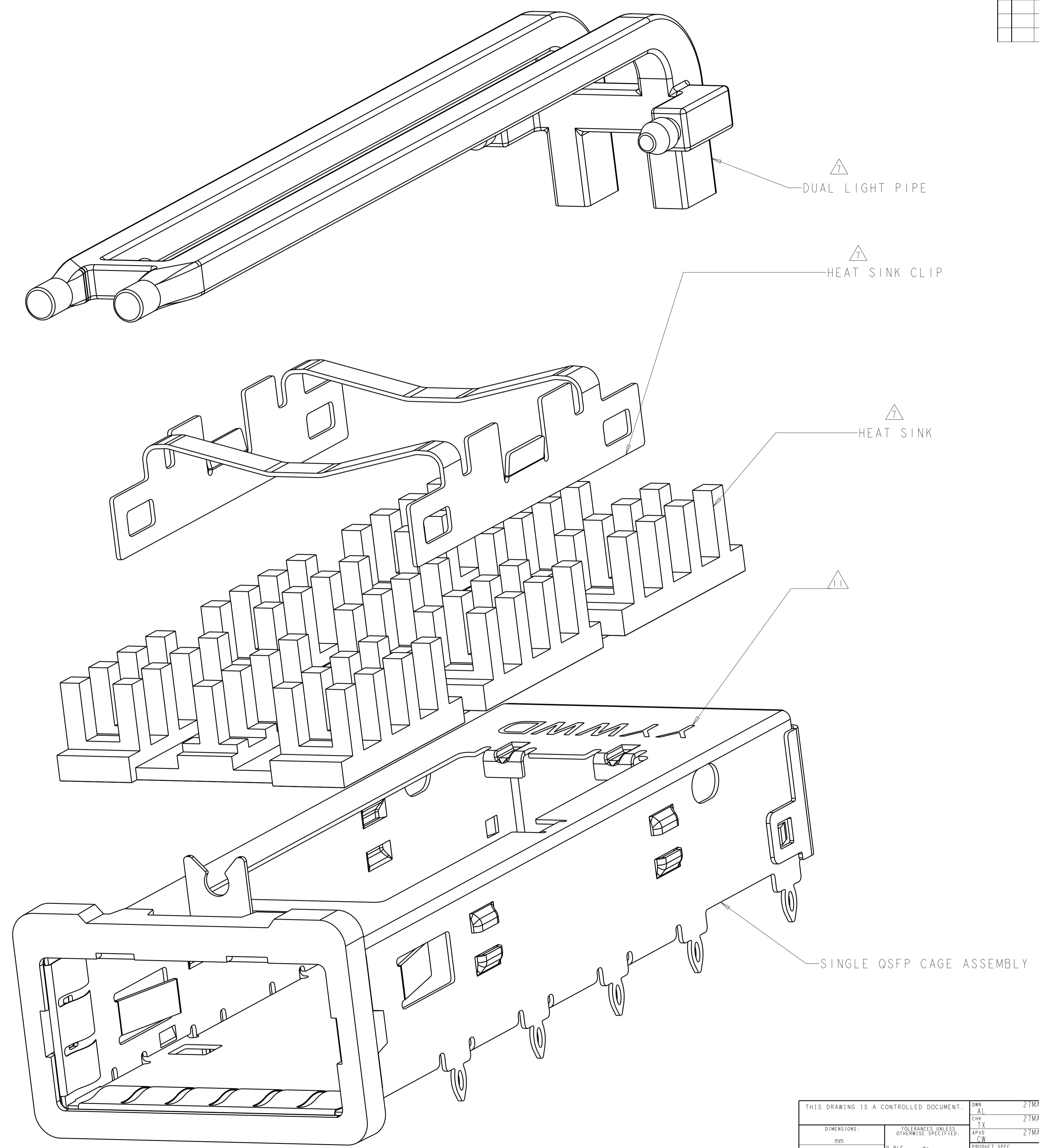

EXPLODED VIEW
 SCALE 8:1

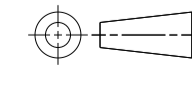
THIS DRAWING IS A CONTROLLED DOCUMENT.		DWN: AL 27MAY2011	 TE Connectivity
DIMENSIONS: mm		CHK: TX 27MAY2011	
TOLERANCES UNLESS OTHERWISE SPECIFIED: 0 PLC ±.5 1 PLC ±0.13 2 PLC ±0.013 3 PLC ±0.001 4 PLC ±.0001 ANGLES ±.1		APVD: CW 27MAY2011	
DIMENSIONS: mm 		PRODUCT SPEC: 108-2286 APPLICATION SPEC: 114-13218 WEIGHT: -	
MATERIAL: -		FINISH: -	NAME: 1XI CAGE ASSEMBLY, BEHIND BEZEL WITH HEAT SINK AND DUAL LIGHT PIPE QSPF SIZE: A100779 CAGE CODE: C=2170112 DRAWING NO: - RESTRICTED TO: - Customer Drawing
SCALE 5:1		SHEET 2 OF 5	REV 3

LOC	DIST	REV	DATE	BY	APPD
GP	00				

REVISIONS			
NO	DESCRIPTION	DATE	BY
-	SEE SHEET 1	-	-

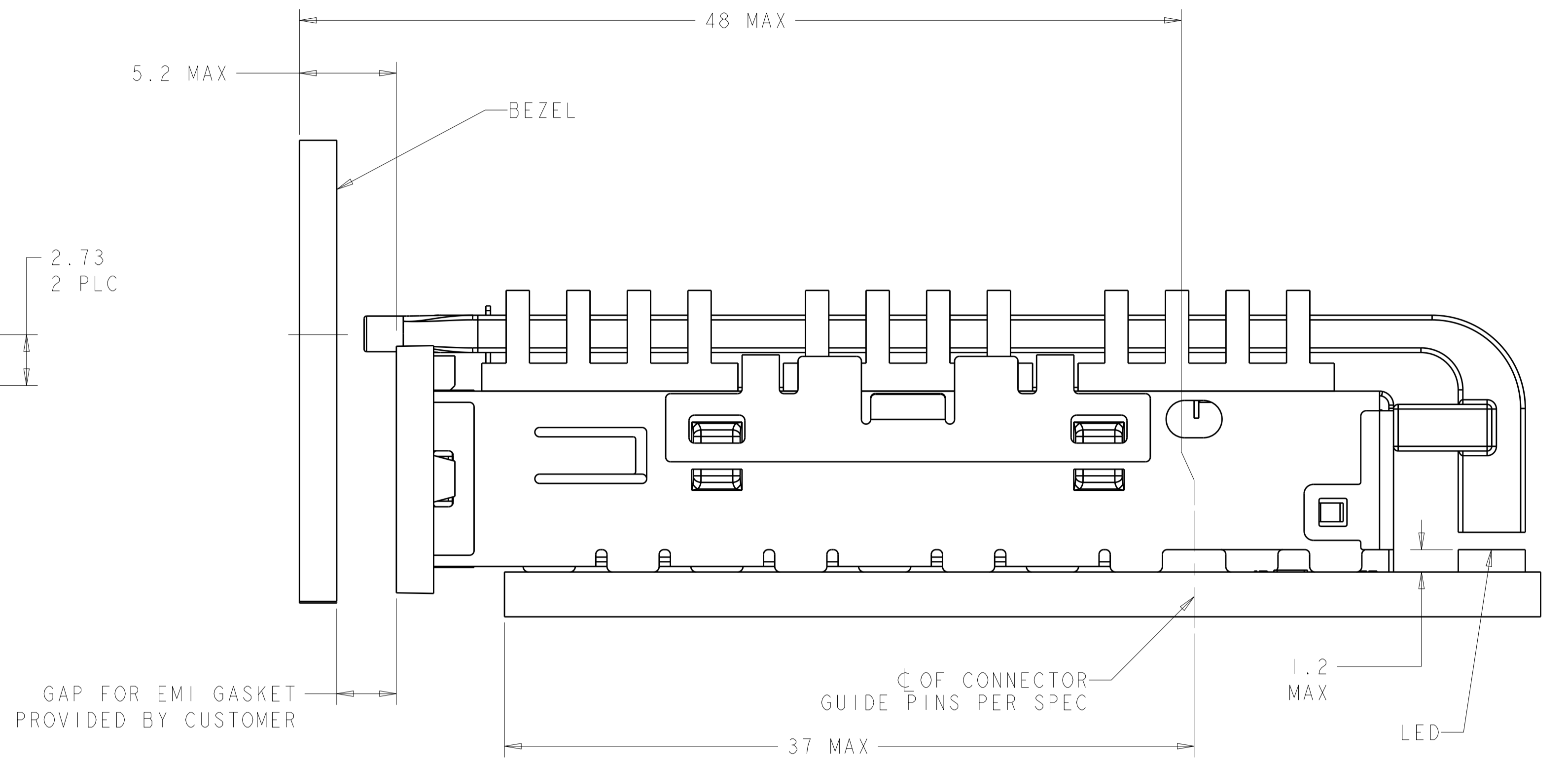
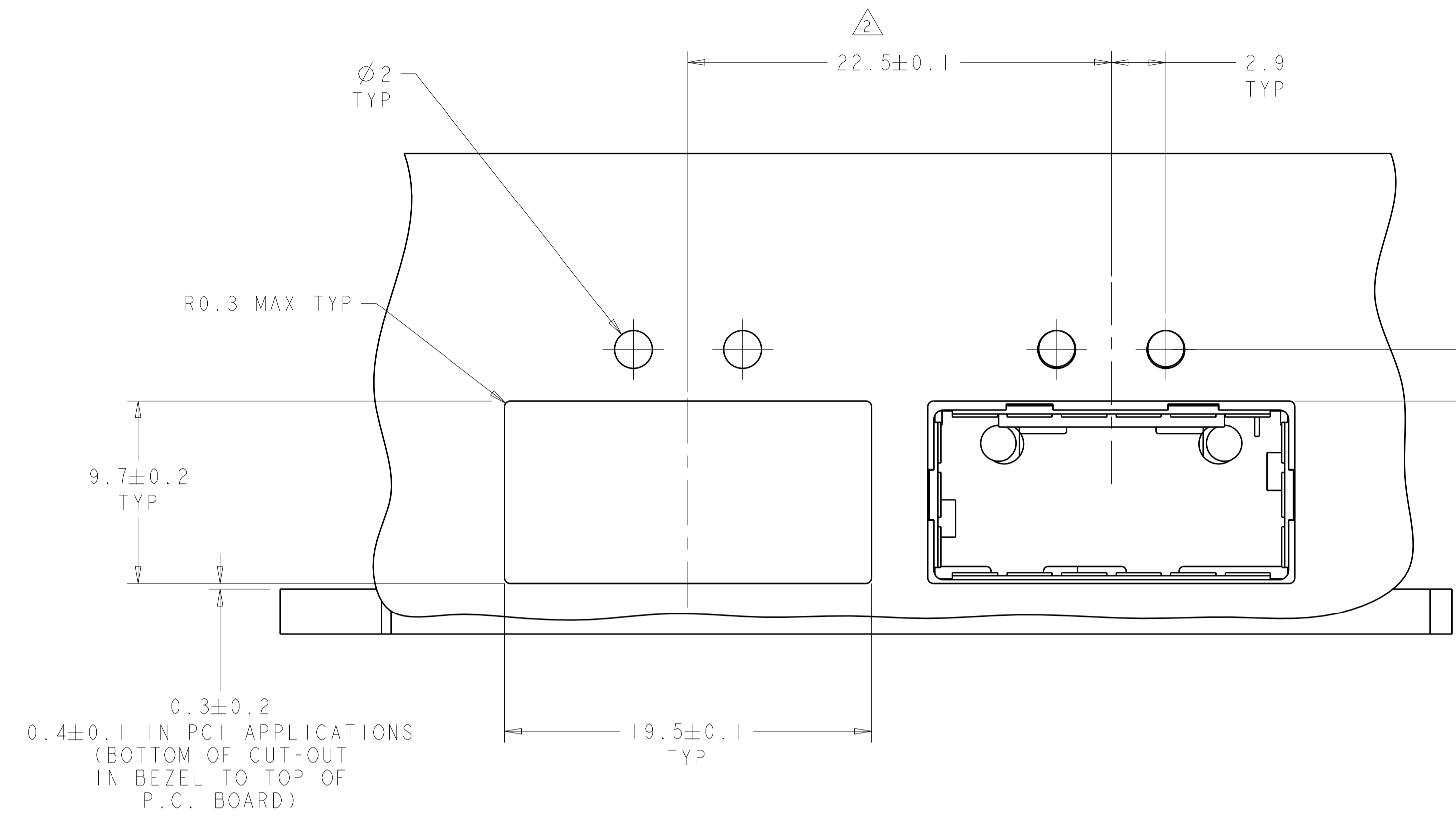

ONE SIDED CONFIGURATION

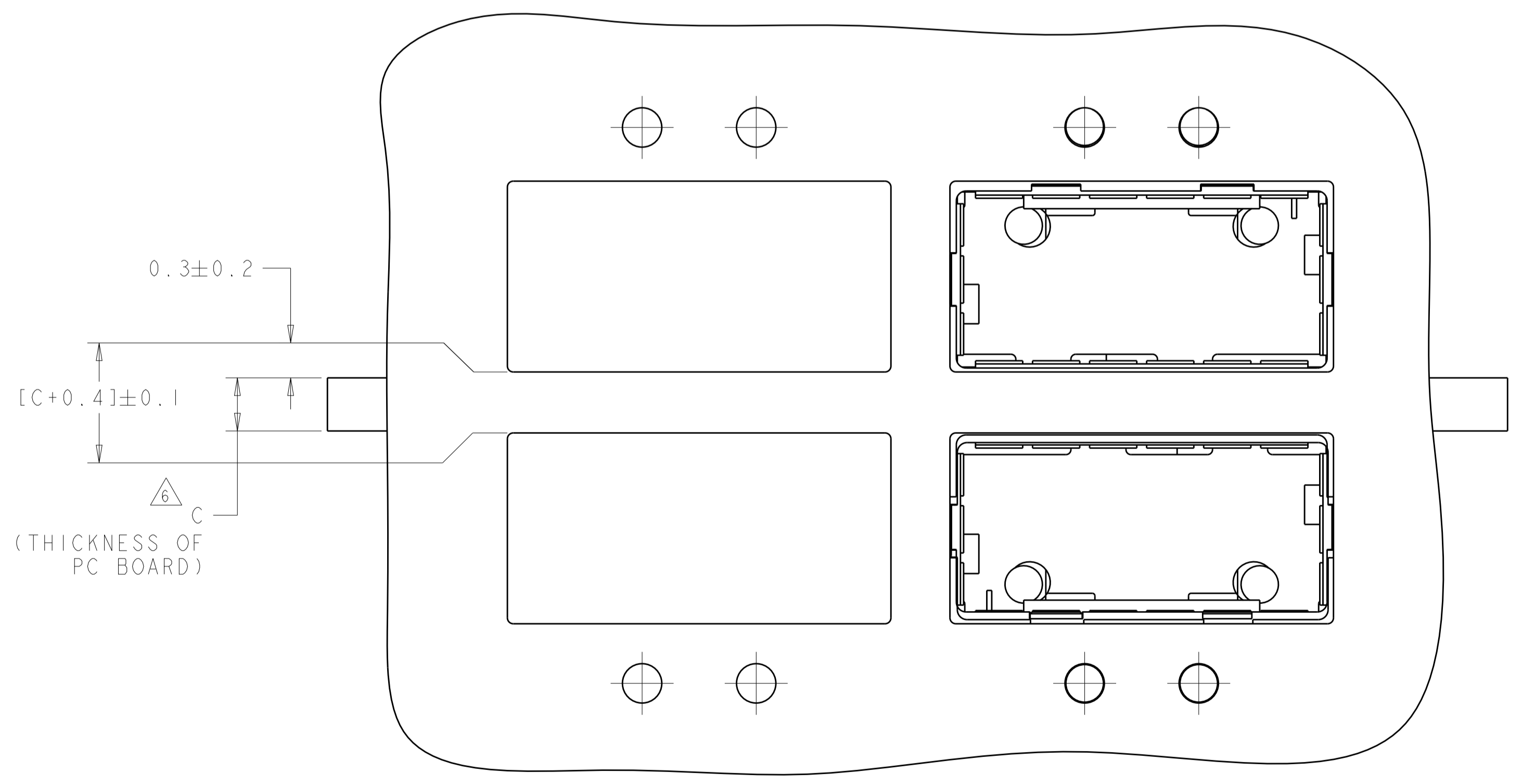

BELLY TO BELLY CONFIGURATION
 SIMILAR TO ONE SIDED EXCEPT
 WHERE NOTED

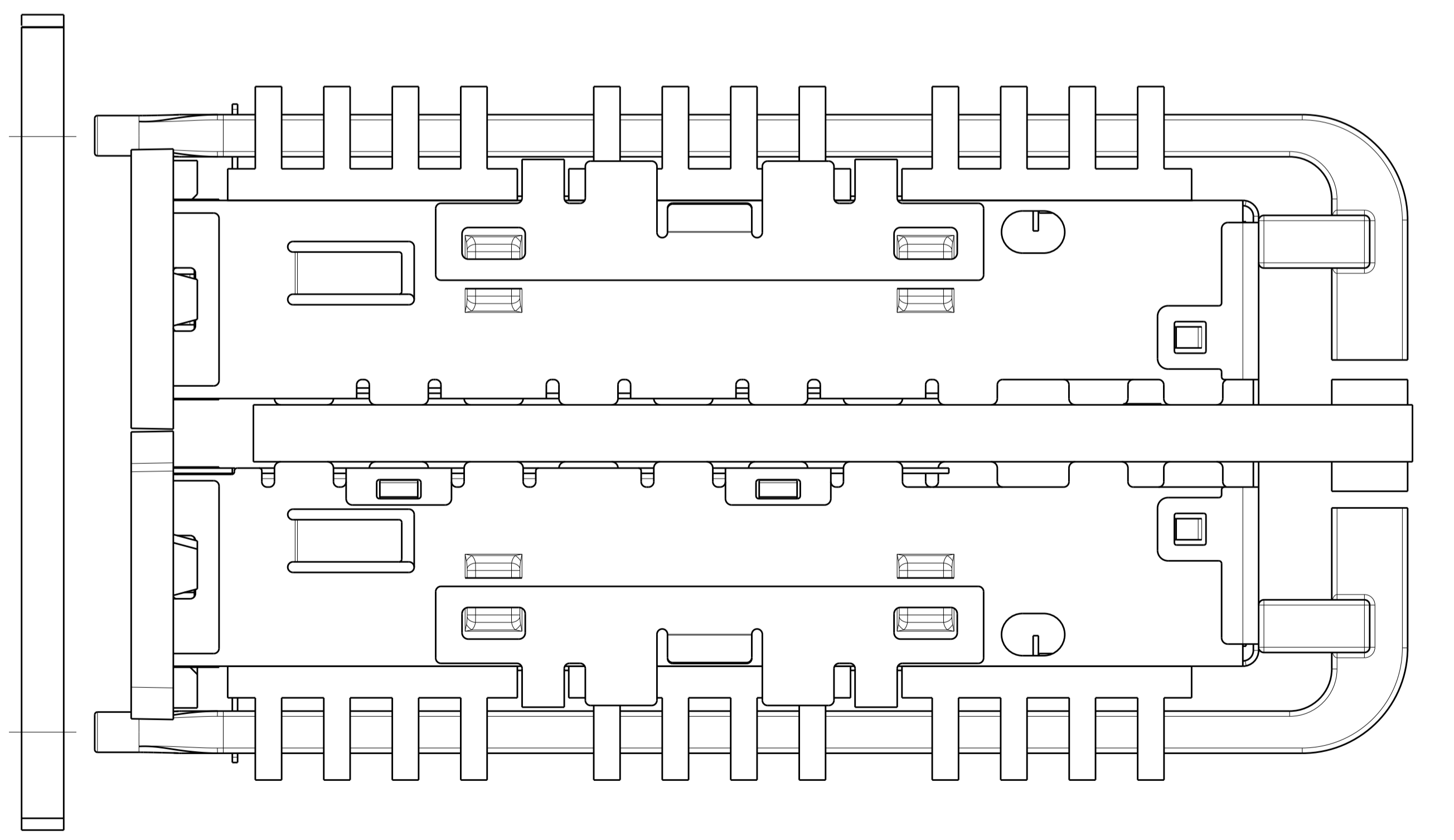

THIS DRAWING IS A CONTROLLED DOCUMENT.		OWN: JAL	27MAY2011	STE TE Connectivity
DIMENSIONS: mm		CHK: TX	27MAY2011	
TOLERANCES UNLESS OTHERWISE SPECIFIED:		APPD: CW	27MAY2011	NAME: 1XI CAGE ASSEMBLY, BEHIND BEZEL WITH HEAT SINK AND DUAL LIGHT PIPE QSFP
0 PLC ±0.5		PRODUCT SPEC	108-2286	
1 PLC ±0.13		APPLICATION SPEC	114-13218	SIZE: CAGE CODE DRAWING NO
2 PLC ±0.013		WEIGHT	-	RESTRICTED TO
3 PLC ±0.013		Customer Drawing	SCALE 5:1	SHEET 3 OF 5
4 PLC ±0.0001				REV 3
ANGLES ±0.0001				
FINISH				

LOC	DIST	REV	DATE	BY	APPV
GP	00				

REVISIONS				
REV	DATE	BY	APPV	DESCRIPTION
-	-	-	-	SEE SHEET 1

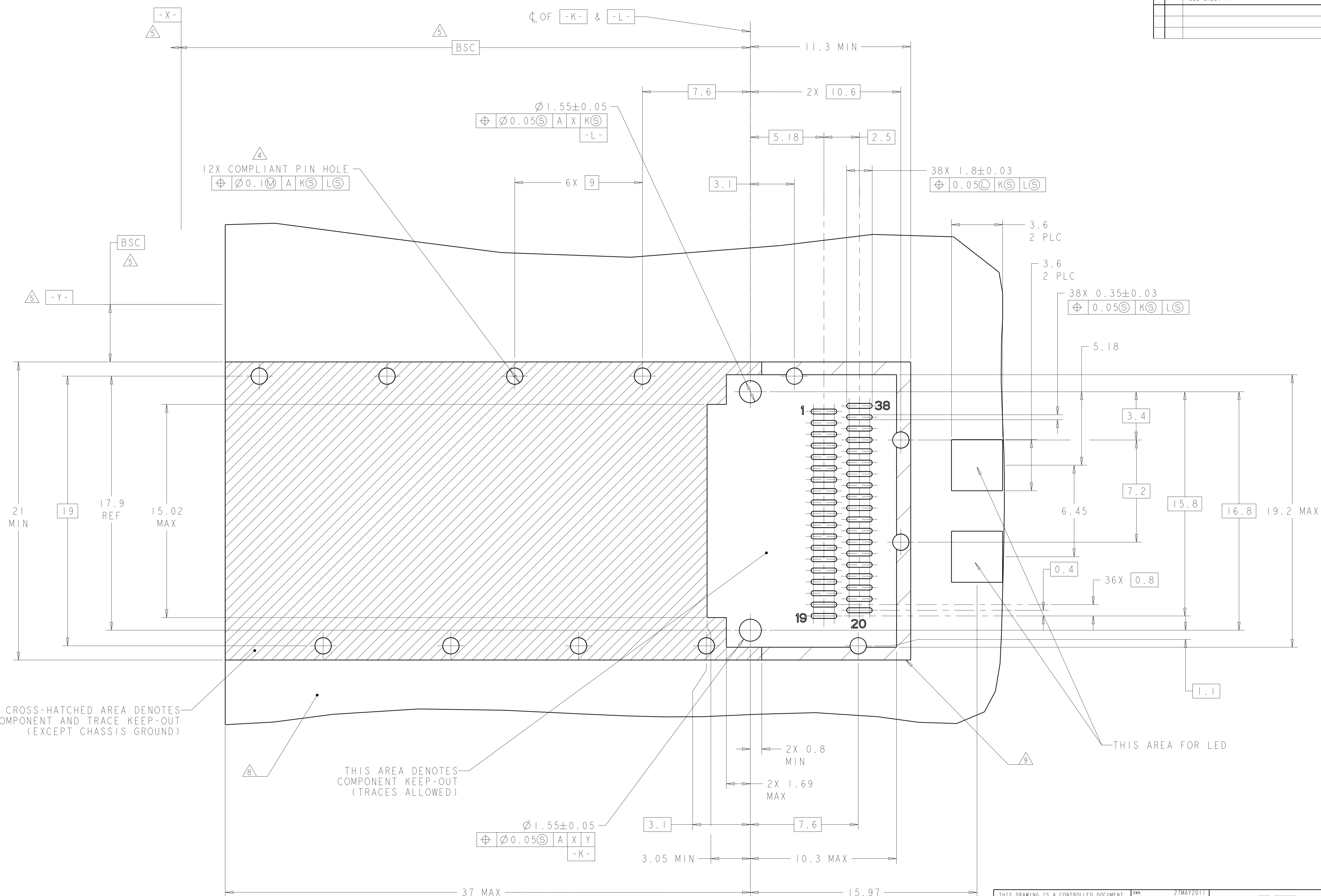

CROSS-HATCHED AREA DENOTES COMPONENT AND TRACE KEEP-OUT (EXCEPT CHASSIS GROUND)

THIS AREA DENOTES COMPONENT KEEP-OUT (TRACES ALLOWED)

THIS AREA FOR LED

RECOMMENDED PCB LAYOUT
 SINGLE SIDED CONFIGURATION
 SCALE 8:1

THIS DRAWING IS A CONTROLLED DOCUMENT.		DWN: 27MAY2011	TE Connectivity
DIMENSIONS: mm		CHK: 27MAY2011	
		TX: 27MAY2011	
TOLERANCES UNLESS OTHERWISE SPECIFIED:		APPV: 27MAY2011	NAME: 1XI CAGE ASSEMBLY, BEHIND BEZEL WITH HEAT SINK AND DUAL LIGHT PIPE QSFP
0 PLC ±0.5	1 PLC ±0.13	PRODUCT SPEC: 108-2286	SIZE: 114-13218
2 PLC ±0.013	3 PLC ±0.013	APPLICATION SPEC: 114-13218	RESTRICTED TO: -
4 PLC ±0.0001	ANGLES ±0.0001	WEIGHT: -	A100779C=2170112
MATERIAL: -	FINISH: -	Customer Drawing	SCALE: 4:1 SHEET 4 OF 5 REV 3

LOC		DIST		REVISONS			
P	LTN	DESCRIPTION	DATE	DWN	APVD		
GP	00	SEE SHEET 1					

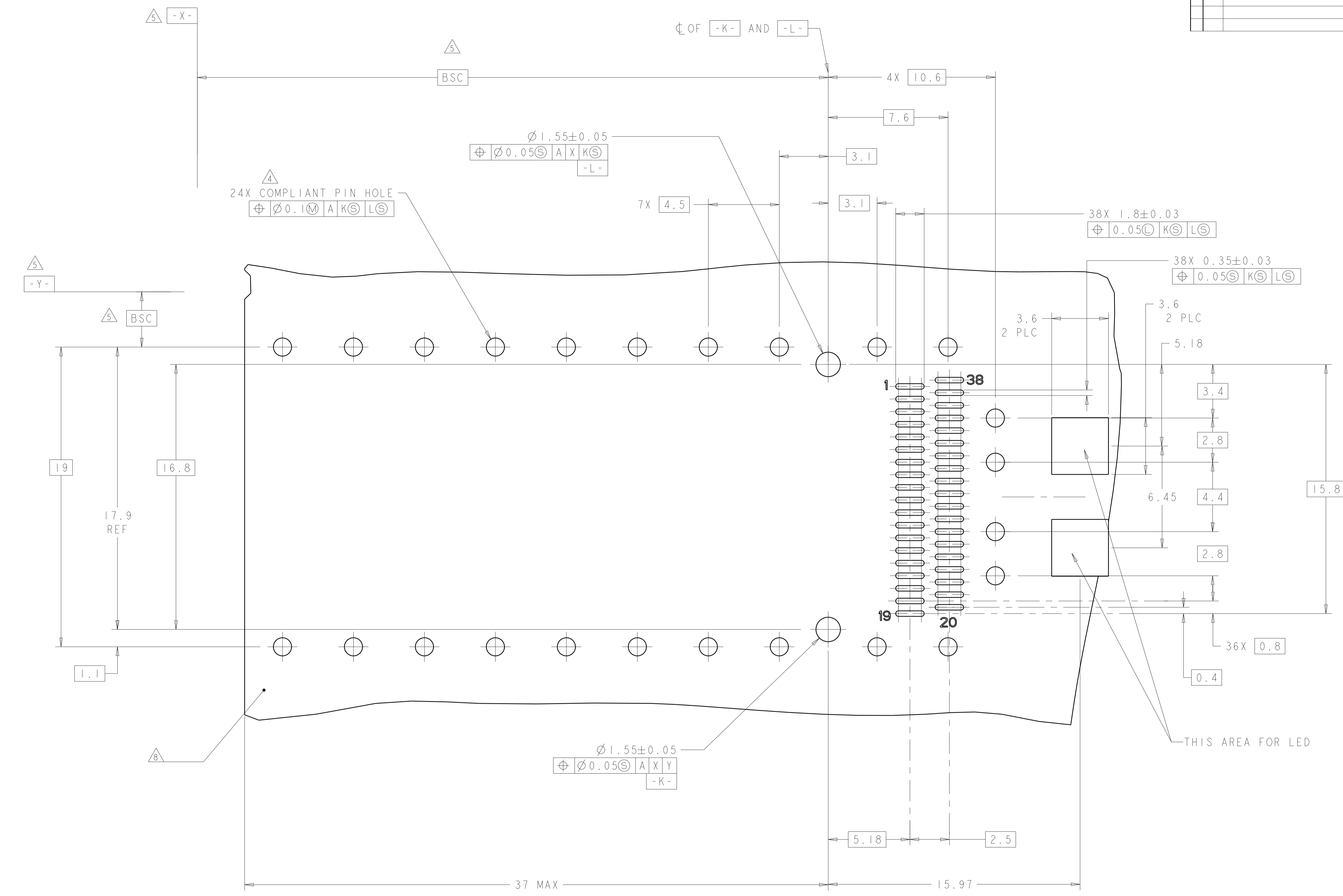

RECOMMENDED PCB LAYOUT
 BELLY TO BELLY CONFIGURATION
 SEE SHEET 4 FOR KEEP OUT AREAS
 SCALE 8:1

THIS DRAWING IS A CONTROLLED DOCUMENT.		DWN: 27MAY2011	TE Connectivity
DIMENSIONS: mm		CHK: 27MAY2011	
		APPV: 27MAY2011	
TOLERANCES UNLESS OTHERWISE SPECIFIED:		PRODUCT SPEC	NAME: 1XI CAGE ASSEMBLY, BEHIND BEZEL WITH HEAT SINK AND DUAL LIGHT PIPE QSFP
0 PLC ±0.5		108-2286	SIZE: CAGE CODE DRAWING NO
1 PLC ±0.13		APPLICATION SPEC	RESTRICTED TO
2 PLC ±0.013		114-13218	A100779C=2170112
3 PLC ±0.001		WEIGHT	SCALE 4:1 SHEET 5 OF 5 REV 3
4 PLC ±0.0001		Customer Drawing	
ANGLES ±0.0001			
FINISH			

Компания «Life Electronics» занимается поставками электронных компонентов импортного и отечественного производства от производителей и со складов крупных дистрибьюторов Европы, Америки и Азии.

С конца 2013 года компания активно расширяет линейку поставок компонентов по направлению коаксиальный кабель, кварцевые генераторы и конденсаторы (керамические, пленочные, электролитические), за счёт заключения дистрибьюторских договоров

Мы предлагаем:

- Конкурентоспособные цены и скидки постоянным клиентам.
- Специальные условия для постоянных клиентов.
- Подбор аналогов.
- Поставку компонентов в любых объемах, удовлетворяющих вашим потребностям.
- Приемлемые сроки поставки, возможна ускоренная поставка.
- Доставку товара в любую точку России и стран СНГ.
- Комплексную поставку.
- Работу по проектам и поставку образцов.
- Формирование склада под заказчика.
- Сертификаты соответствия на поставляемую продукцию (по желанию клиента).
- Тестирование поставляемой продукции.
- Поставку компонентов, требующих военную и космическую приемку.
- Входной контроль качества.
- Наличие сертификата ISO.

В составе нашей компании организован Конструкторский отдел, призванный помогать разработчикам, и инженерам.

Конструкторский отдел помогает осуществить:

- Регистрацию проекта у производителя компонентов.
- Техническую поддержку проекта.
- Защиту от снятия компонента с производства.
- Оценку стоимости проекта по компонентам.
- Изготовление тестовой платы монтаж и пусконаладочные работы.



Тел: +7 (812) 336 43 04 (многоканальный)

Email: org@lifeelectronics.ru