

Stud-Mounted Silicon Rectifier Diodes, 15 A



DO-203AB (DO-5)

DESCRIPTION/FEATURES

- Low thermal impedance
- High case temperature
- Excellent reliability
- Maximum design flexibility
- Can be made to meet stringent military, aerospace and other high reliability requirements
- Compliant to RoHS directive 2002/95/EC

**RoHS
COMPLIANT**
PRODUCT SUMMARY

$I_{F(AV)}$	15 A
-------------	------

MAJOR RATINGS AND CHARACTERISTICS

PARAMETER	TEST CONDITIONS	VALUES	UNITS
$I_{F(AV)}$		15 ⁽¹⁾	A
	T_C	150 ⁽¹⁾	°C
I_{FSM}	50 Hz	239	A
	60 Hz	250 ⁽¹⁾	
I^2t	50 Hz	286	A ² s
	60 Hz	260	
$I^2\sqrt{t}$		3870	A ² √s
V_{RRM}	Range	50 to 600	V
T_J		- 65 to 175	°C

Note
⁽¹⁾ JEDEC registered values

ELECTRICAL SPECIFICATIONS
VOLTAGE RATINGS

TYPE NUMBER	V_{RRM} , MAXIMUM REPETITIVE PEAK REVERSE VOLTAGE ($T_J = - 65\text{ °C}$ TO 175 °C) V	V_{RM} , MAXIMUM DIRECT REVERSE VOLTAGE ($T_J = - 65\text{ °C}$ TO 175 °C) V
1N3208	50 ⁽¹⁾	50 ⁽¹⁾
1N3209	100 ⁽¹⁾	100 ⁽¹⁾
1N3210	200 ⁽¹⁾	200 ⁽¹⁾
1N3211	300 ⁽¹⁾	300 ⁽¹⁾
1N3212	400 ⁽¹⁾	400 ⁽¹⁾
1N3213	500 ⁽¹⁾	500 ⁽¹⁾
1N3214	600 ⁽¹⁾	600 ⁽¹⁾

Notes
⁽¹⁾ JEDEC registered values

- Basic type number indicates cathode to case. For anode to case, add "R" to part number, e.g. 1N3208R, 1N3209R

FORWARD CONDUCTION					
PARAMETER	SYMBOL	TEST CONDITIONS		VALUES	UNITS
Maximum average forward current at case temperature	$I_{F(AV)}$	180° sinusoidal conduction		15 ⁽¹⁾	A
				150 ⁽¹⁾	°C
Maximum peak one cycle non-repetitive surge current	I_{FSM}	Half cycle 50 Hz sine wave or 6 ms rectangular pulse	Following any rated load condition and with rated V_{RRM} applied	239	A
		Half cycle 60 Hz sine wave or 5 ms rectangular pulse		250 ⁽¹⁾	
		Half cycle 50 Hz sine wave or 6 ms rectangular pulse	Following any rated load condition and with V_{RRM} applied following surge = 0	284	
		Half cycle 60 Hz sine wave or 5 ms rectangular pulse		297	
Maximum I^2t for fusing	I^2t	t = 10 ms	With rated V_{RRM} applied following surge, initial $T_J = 150\text{ °C}$	286	A ² s
		t = 8.3 ms		260	
Maximum I^2t for individual device fusing		t = 10 ms	With $V_{RRM} = 0$ following surge, initial $T_J = 150\text{ °C}$	403	
		t = 8.3 ms		368	
Maximum $I^2\sqrt{t}$ for individual device fusing	$I^2\sqrt{t}$ ⁽²⁾	t = 0.1 ms to 10 ms, $V_{RRM} = 0$ following surge		3870	A ² √s
Maximum forward voltage drop	V_{FM}	$I_{F(AV)} = 15\text{ A}$ (47.1 A peak), $T_C = 150\text{ °C}$		1.5 ⁽¹⁾	V
Maximum average reverse current	$I_{R(AV)}$	Maximum rated $I_{F(AV)}$ and $T_C = 150\text{ °C}$		10 ⁽¹⁾	mA

Notes

⁽¹⁾ JEDEC registered values

⁽²⁾ I^2t for time $t_x = I^2\sqrt{t} \times \sqrt{t_x}$

THERMAL AND MECHANICAL SPECIFICATIONS					
PARAMETER	SYMBOL	TEST CONDITIONS		VALUES	UNITS
Maximum junction operating and storage temperature range	T_J, T_{Stg}			- 65 to 175 ⁽¹⁾	°C
Maximum internal thermal resistance, junction to case	R_{thJC}	DC operation		0.65	°C/W
Thermal resistance, case to sink	R_{thCS}	Mounting surface, smooth, flat and greased		0.25	
Maximum allowable mounting torque (+ 0 %, - 10 %)		Not lubricated thread, tightening on nut ⁽²⁾		3.4 (30)	
		Lubricated thread, tightening on nut ⁽²⁾		2.3 (20)	
		Not lubricated thread, tightening on hexagon ⁽³⁾		4.2 (37)	
		Lubricated thread, tightening on hexagon ⁽³⁾		3.2 (28)	
Weight				28.5	g
				1	oz.
Case style		JEDEC		DO-203AB (DO-5)	

Notes

⁽¹⁾ JEDEC registered values

⁽²⁾ Recommended for pass-through holes

⁽³⁾ Recommended for holed threaded heatsinks



Fig. 1 - Average Forward Current vs. Maximum Allowable Case Temperature



Fig. 3 - Maximum Low Level Forward Power Loss vs. Average Forward Current



Fig. 2 - Maximum Non-Repetitive Surge Current vs. Number of Current Pulses

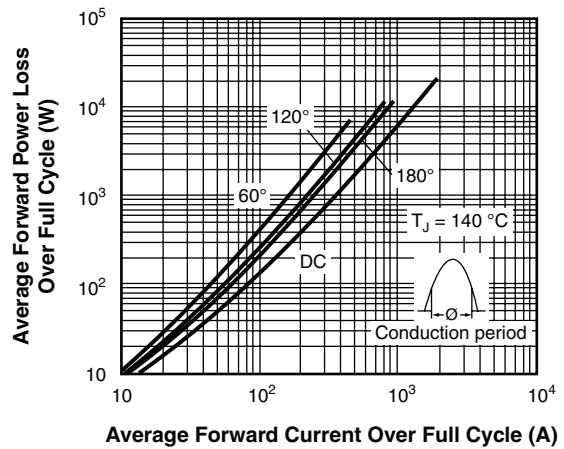

Fig. 4 - Maximum High Level Forward Power Loss vs. Average Forward Current



Fig. 5 - Maximum Forward Voltage vs. Forward Current

LINKS TO RELATED DOCUMENTS

Dimensions

www.vishay.com/doc?95360

DO-203AB (DO-5) for 1N1183, 1N3765, 1N1183A, 1N2128A, 1N3208 Series

DIMENSIONS in millimeters (inches)

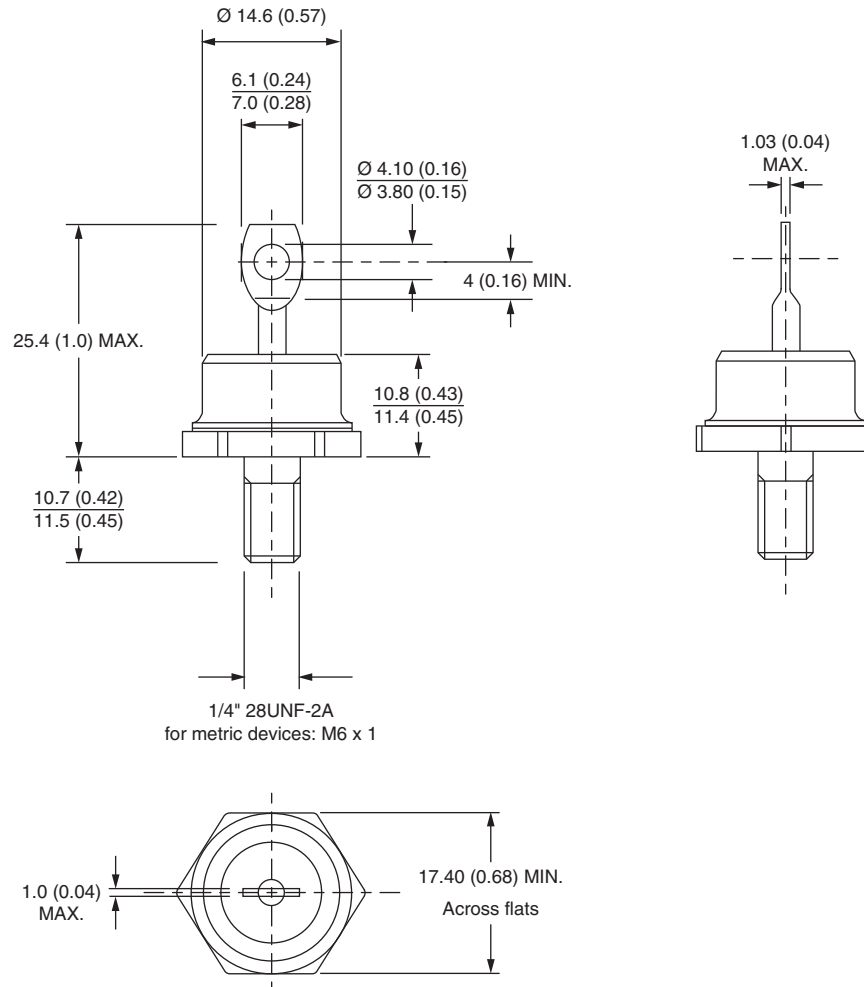



Disclaimer

ALL PRODUCT, PRODUCT SPECIFICATIONS AND DATA ARE SUBJECT TO CHANGE WITHOUT NOTICE TO IMPROVE RELIABILITY, FUNCTION OR DESIGN OR OTHERWISE.

Vishay Intertechnology, Inc., its affiliates, agents, and employees, and all persons acting on its or their behalf (collectively, "Vishay"), disclaim any and all liability for any errors, inaccuracies or incompleteness contained in any datasheet or in any other disclosure relating to any product.

Vishay makes no warranty, representation or guarantee regarding the suitability of the products for any particular purpose or the continuing production of any product. To the maximum extent permitted by applicable law, Vishay disclaims (i) any and all liability arising out of the application or use of any product, (ii) any and all liability, including without limitation special, consequential or incidental damages, and (iii) any and all implied warranties, including warranties of fitness for particular purpose, non-infringement and merchantability.

Statements regarding the suitability of products for certain types of applications are based on Vishay's knowledge of typical requirements that are often placed on Vishay products in generic applications. Such statements are not binding statements about the suitability of products for a particular application. It is the customer's responsibility to validate that a particular product with the properties described in the product specification is suitable for use in a particular application. Parameters provided in datasheets and/or specifications may vary in different applications and performance may vary over time. All operating parameters, including typical parameters, must be validated for each customer application by the customer's technical experts. Product specifications do not expand or otherwise modify Vishay's terms and conditions of purchase, including but not limited to the warranty expressed therein.

Except as expressly indicated in writing, Vishay products are not designed for use in medical, life-saving, or life-sustaining applications or for any other application in which the failure of the Vishay product could result in personal injury or death. Customers using or selling Vishay products not expressly indicated for use in such applications do so at their own risk and agree to fully indemnify and hold Vishay and its distributors harmless from and against any and all claims, liabilities, expenses and damages arising or resulting in connection with such use or sale, including attorneys fees, even if such claim alleges that Vishay or its distributor was negligent regarding the design or manufacture of the part. Please contact authorized Vishay personnel to obtain written terms and conditions regarding products designed for such applications.

No license, express or implied, by estoppel or otherwise, to any intellectual property rights is granted by this document or by any conduct of Vishay. Product names and markings noted herein may be trademarks of their respective owners.

Material Category Policy

Vishay Intertechnology, Inc. hereby certifies that all its products that are identified as RoHS-Compliant fulfill the definitions and restrictions defined under Directive 2011/65/EU of The European Parliament and of the Council of June 8, 2011 on the restriction of the use of certain hazardous substances in electrical and electronic equipment (EEE) - recast, unless otherwise specified as non-compliant.

Please note that some Vishay documentation may still make reference to RoHS Directive 2002/95/EC. We confirm that all the products identified as being compliant to Directive 2002/95/EC conform to Directive 2011/65/EU.

Компания «Life Electronics» занимается поставками электронных компонентов импортного и отечественного производства от производителей и со складов крупных дистрибьюторов Европы, Америки и Азии.

С конца 2013 года компания активно расширяет линейку поставок компонентов по направлению коаксиальный кабель, кварцевые генераторы и конденсаторы (керамические, пленочные, электролитические), за счёт заключения дистрибьюторских договоров

Мы предлагаем:

- Конкурентоспособные цены и скидки постоянным клиентам.
- Специальные условия для постоянных клиентов.
- Подбор аналогов.
- Поставку компонентов в любых объемах, удовлетворяющих вашим потребностям.
- Приемлемые сроки поставки, возможна ускоренная поставка.
- Доставку товара в любую точку России и стран СНГ.
- Комплексную поставку.
- Работу по проектам и поставку образцов.
- Формирование склада под заказчика.
- Сертификаты соответствия на поставляемую продукцию (по желанию клиента).
- Тестирование поставляемой продукции.
- Поставку компонентов, требующих военную и космическую приемку.
- Входной контроль качества.
- Наличие сертификата ISO.

В составе нашей компании организован Конструкторский отдел, призванный помогать разработчикам, и инженерам.

Конструкторский отдел помогает осуществить:

- Регистрацию проекта у производителя компонентов.
- Техническую поддержку проекта.
- Защиту от снятия компонента с производства.
- Оценку стоимости проекта по компонентам.
- Изготовление тестовой платы монтаж и пусконаладочные работы.



Тел: +7 (812) 336 43 04 (многоканальный)

Email: org@lifeelectronics.ru