

TW8824

LCD Video Processor with Built-in Decoder, TTL Inputs, BT.656 Output and LVDS Panel Interface

FN8667
Rev 1.00
February 26, 2015

The TW8824 is a highly integrated LCD video processor that incorporates many of the key features required to create a multipurpose LCD display system into a single package. This includes a high quality 2D comb NTSC/PAL/SECAM video decoder, which supports both single-ended and differential CVBS signals, a digital RGB input interface, high quality scaler and deinterlacer, a Font OSD engine and LVDS, TTL or TCON output panel interfaces. The TW8824 can support input resolutions up to 1080p and can drive LCD panels at resolutions up to 1366x768. The TW8824's video processing capability includes arbitrary H/V scaling, panoramic scaling, image mirroring, image adjustment and enhancement, black and white stretch, etc. This device can support fast boot system requirements and provides stability and reliability to the system due to the fact that it is a hardwired solution that can sync to the video source and display an image on the LCD in less than 0.5 seconds from start-up. The feature set and versatility of this device makes it an ideal solution for in-car LCD display applications.

Applications

- Automotive display systems

Features

Analog Video Decoder

- NTSC (M, 4.43) and PAL (B, D, G, H, I, M, N, N combination), PAL (60), SECAM with automatic format detection
- 10-bit ADC and analog clamping circuit
- Fully programmable static gain or automatic gain control for CVBS channel
- Programmable white peak control for the CVBS channel
- High quality adaptive 2D comb filter for both NTSC and PAL inputs
- PAL delay line for color phase error correction
- Image enhancement with 2D dynamic peaking/CTI
- Digital sub-carrier PLL for accurate color decoding
- Programmable hue, brightness, saturation, contrast, sharpness
- Selectable differential or single-ended CVBS input
- Digital horizontal PLL and advanced synchronization processing for VCR playback and weak signal performance
- High quality horizontal and vertical filtered down scaling with arbitrary scale down ratio
- Up to 3-CH differential or 6-CH single-ended CVBS input

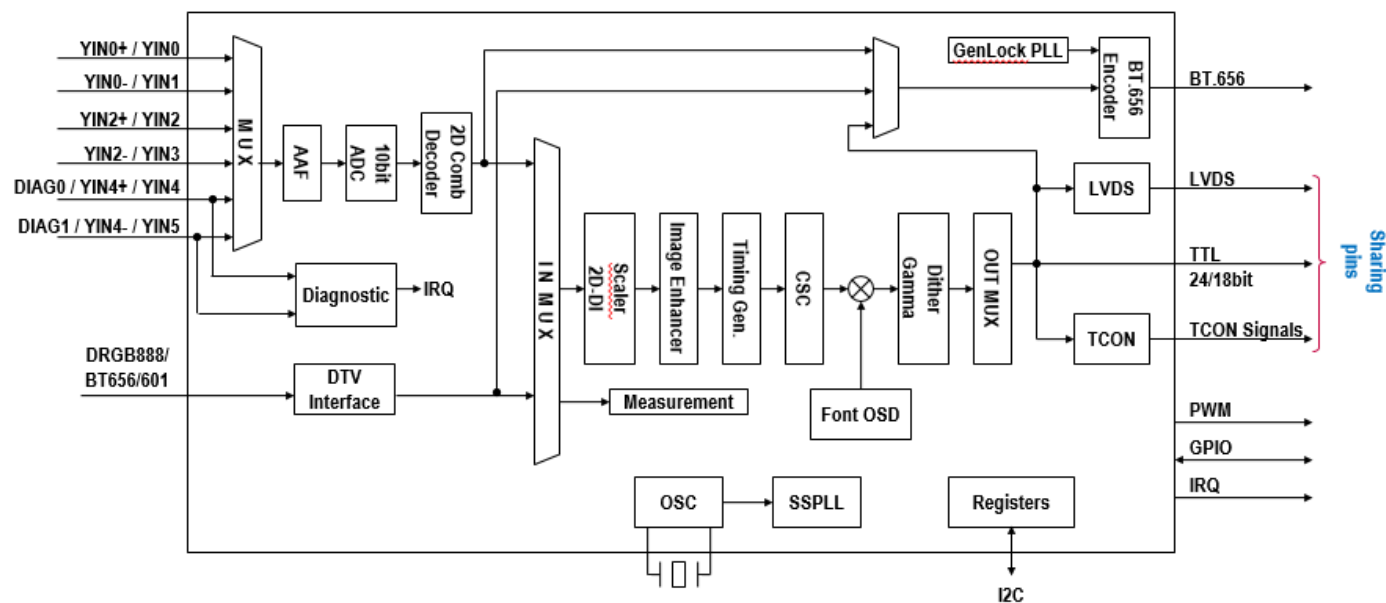

FIGURE 1. FUNCTIONAL BLOCK DIAGRAM

Features (Continued)

Digital Inputs Support

- Supports RGB 24-bit input up to 1080p resolution at either 1.8V or 3.3V logic level
- Supports both BT.656 and 601 video formats with H/VSYNC

TFT Panel Support

- Built-in programmable timing controller
- Supports 3, 4, 6 or 8 bits per pixel up to 16.8 million colors with built-in dithering engine
- Supports digital panels (TTL) or single channel LVDS panels up to WXGA (1366x768) resolution, 85MHz
- Supports serial (8-bit) RGB panel

Timing Controller (TCON)

- Supports programmable interface signals for control
- Column (source) driver/row (gate) driver

BT.656 Output

- Independent ITU-R 656 compatible YCbCr(4:2:2) output format
- ITU-R 656 output generated from decoder, DRGB and post scaling path
- Max 148.5MHz with 3.3V, 74MHz with 1.8V

Font Based On Screen Display

- Four window font OSD with bordering/shadow
- 6912B programmable font RAM and 512 display RAM
- 1/2/3/4 bits/pixel
- Supports variable width (12/16), height (2~32)

Image Processing

- High quality scaler with both up/down and panorama/water-glass scaling support
- Built-in 2D de-interlacing function
- Programmable brightness, contrast, saturation, hue and sharpness
- Programmable color transient improvement control
- Supports programmable cropping of input video and graphics
- Independent RGB gain and offset controls
- DTV hue adjustment
- Programmable 8-bit Gamma correction for each color
- Black/White Stretch

Clock Generation

- Spread spectrum profile based on triangular modulation with center spread
- Programmable modulation frequency and spread width

Miscellaneous

- Supports Fast Mode I²C interface up to 400Kbps
- Short Diagnostics:
 - Short-to-battery
 - Short-to-ground
- Up to 3 PWM outputs
- GPIOs
- 1.8V internal operation
- 1.8V/3.3V DTV input support
- 1.8V/3.3V BT.656 output support
- Hardware mute pin
- Single 27MHz crystal
- 100 pin TQFP
- TW8824AT-TA1-GR is AEC-Q100 qualified

© Copyright Intersil Americas LLC 2014-2015. All Rights Reserved.
All trademarks and registered trademarks are the property of their respective owners.

For additional products, see www.intersil.com/en/products.html

Intersil products are manufactured, assembled and tested utilizing ISO9001 or TS16949 quality systems as applicable noted in the quality certifications found at www.intersil.com/en/support/qualandreliability.html

Intersil products are sold by description only. Intersil may modify the circuit design and/or specifications of products at any time without notice, provided that such modification does not, in Intersil's sole judgment, affect the form, fit or function of the product. Accordingly, the reader is cautioned to verify that datasheets are current before placing orders. Information furnished by Intersil is believed to be accurate and reliable. However, no responsibility is assumed by Intersil or its subsidiaries for its use; nor for any infringements of patents or other rights of third parties which may result from its use. No license is granted by implication or otherwise under any patent or patent rights of Intersil or its subsidiaries.

For information regarding Intersil Corporation and its products, see www.intersil.com

Компания «Life Electronics» занимается поставками электронных компонентов импортного и отечественного производства от производителей и со складов крупных дистрибьюторов Европы, Америки и Азии.

С конца 2013 года компания активно расширяет линейку поставок компонентов по направлению коаксиальный кабель, кварцевые генераторы и конденсаторы (керамические, пленочные, электролитические), за счёт заключения дистрибьюторских договоров

Мы предлагаем:

- Конкурентоспособные цены и скидки постоянным клиентам.
- Специальные условия для постоянных клиентов.
- Подбор аналогов.
- Поставку компонентов в любых объемах, удовлетворяющих вашим потребностям.
- Приемлемые сроки поставки, возможна ускоренная поставка.
- Доставку товара в любую точку России и стран СНГ.
- Комплексную поставку.
- Работу по проектам и поставку образцов.
- Формирование склада под заказчика.
- Сертификаты соответствия на поставляемую продукцию (по желанию клиента).
- Тестирование поставляемой продукции.
- Поставку компонентов, требующих военную и космическую приемку.
- Входной контроль качества.
- Наличие сертификата ISO.

В составе нашей компании организован Конструкторский отдел, призванный помогать разработчикам, и инженерам.

Конструкторский отдел помогает осуществить:

- Регистрацию проекта у производителя компонентов.
- Техническую поддержку проекта.
- Защиту от снятия компонента с производства.
- Оценку стоимости проекта по компонентам.
- Изготовление тестовой платы монтаж и пусконаладочные работы.



Тел: +7 (812) 336 43 04 (многоканальный)
Email: org@lifeelectronics.ru