

# Power Supply, Primary Switch Mode, Narrow Design MINI-PS-100-240AC/10-15DC/2

---

## MINI POWER provides:

- **Extra narrow** widths of 22.5, 45, and 67.5 mm (0.886, 1.772, and 2.657 in.)
- **Global use** due to a wide range input
- **A high level of operational safety** in complex global networks
- **Reliable startup** of heavy loads due to POWER BOOST

The reliability of a power supply determines the availability of individual components in a system and whether complex systems can function safely.

The globalization of markets increases the demands placed on the power supply. A wide range input and a high level of availability are required. These requirements are met by MINI POWER.



## 1. Short Description

MINI POWER is the extra narrow power supply, which is available in widths of 22.5, 45, and 67.5 mm (0.886, 1.772, and 2.657 in.).

In addition to a 24 V version with output currents of 1 A, 2 A, and 4 A, special voltages are also available with 5 V/3 A, +/-15 V/1 A, and 10 - 15 V/2 A.

Reliable startup of heavy loads is ensured by a power reserve of up to 100% - the POWER BOOST.

The high level of operational safety is also ensured in complex global networks. MINI POWER also operates in applications where static voltage dips, transient power supply failures or phase failure are common.

Large capacitors ensure mains buffering of more than 20 ms at full load.

## 2. Area of Application

MINI POWER can be used globally due to the consistent provision of a wide range input.

In this way, your entire system can be tested at any production location in the world and can be delivered to any location in the world without faulty switching of the input voltage. This reduces storage costs and logistical effort.

An international approval package including UL 60950 for IT equipment and UL 508 for industrial control equipment enables the device to be used globally.

### 3. Technical Data

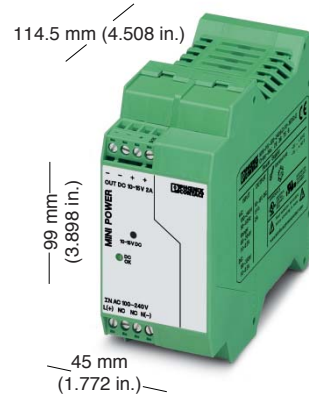
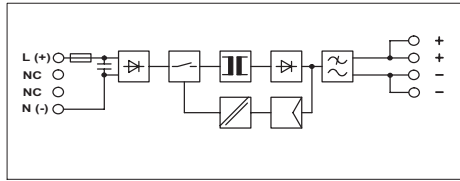

### MINI-PS-100-240AC/10-15DC/2

7	solid	flexible	torque	
	[mm <sup>2</sup> ]		AWG	[Nm] [lb in.]
Input	0.2 - 2.5	0.2 - 2.5	25 - 14	0.5 - 0.6 4.4 - 5.3
Output	0.2 - 2.5	0.2 - 2.5	24 - 14	0.5 - 0.6 4.4 - 5.3

1 AC



Description

**Power Supply,**  
Primary switch mode, narrow design

Type

MINI-PS-100-240AC/10-15DC/2

Order No.

29 38 75 6

Pcs. Pkt.

1

#### Technical Data

##### Input Data ①

Nominal input voltage  
Input voltage range  
Frequency  
Current consumption (for nominal values)  
Inrush current limiting/ $I^2t$  (+25°C [+77°F])  
Mains buffering for a nominal load (typical)  
Switch-on time after applying the mains voltage  
Transient surge voltage protection  
Input fuse, internal  
Recommended fuse

100 - 240 V AC (wide range input)  
85 - 264 V AC 90 - 350 V DC  
45 - 65 Hz 0 Hz  
0.4 A (120 V AC)/0.2 A (230 V AC), approximately  
< 20 A/< 1.7 A<sup>2</sup>s, typical  
> 20 ms  
< 1 s  
Input filter  
2 AT (device protection)  
Circuit breaker 10 A or 16 A  
Characteristic B (EN 60 898)

##### Output Data ②

Nominal output voltage  $U_N$ /tolerance  
Setting range for the output voltage  
Output current during convection cooling  
and nominal values POWER BOOST  $I_{BOOST}$  ( $t = 2$  min., typical)  
Nominal output current  $I_N$  -25°C to +60°C (-13°F to +140°F)  
-25°C to +40°C (-13°F to +104°F)  
Derating  
Short-circuit current limit  
Startup of capacitive loads  
System deviation on:  
Load change static 10 - 90%  
Load change dynamic 10 - 90%  
Input voltage change ±10%  
No load/nominal load  
Maximum power loss  
Level of efficiency (typical)  
Response time  $U_{OUT}$  (10% - 90%)  
Residual ripple/switching peaks (20 MHz)  
Can be connected in parallel  
Internal surge voltage protection

12 V DC±1% (default)  
10 - 15 V DC  
2.3 A ( $U_{out} = 10 - 15$  V DC)  
2 A ( $U_{out} = 10 - 15$  V DC)  
2.3 A ( $U_{out} = 10 - 15$  V DC)  
From +60°C (+140°F), 5% per Kelvin  
< 3.4 A  
Unlimited  
< 1%, typical  
< 3%, typical  
< 0.1%, typical  
1 W/7 W  
86% (for 230 V AC and nominal values)  
< 100 ms, typical  
< 100 mV<sub>pp</sub> (for nominal values)  
To increase redundancy and power  
Yes, limited to 20 V DC, approximately



##### Signal Output Data

LED ( $U_{out} > 0.9 \times U_N \hat{=}$  LED permanently on)

Green LED

**Power Supply, Primary Switch Mode, Narrow Design – MINI-PS-100-240AC/10-15DC/2**

<b>General Data</b>	
Insulation voltage: Approval package Safety transformers for switched-mode power supply units Electrical safety (of IT equipment) Industrial control equipment Equipping high voltage installations with electronic equipment Safety extra-low voltage	Input/output
Safe isolation Protection against dangerous shock currents, basic requirements for safe isolation in electrical equipment Limitation of harmonic line currents	
Mounting position Can be mounted with spacing	- Vertical - Horizontal
Degree of protection Class of protection MTBF Housing version Dimensions (W x H x D) Weight	

3 kV AC/(type test)/4 kV AC (routine test)  EN 61 558-2-17 EN 60950/VDE 0805 UL/C-UL Recognized UL 60 950  <sup>1)</sup> UL/C-UL Listed UL 508  <sup>1)</sup> LISTED
EN 50 178/VDE 0160 (Surge Voltage Category III) PELV (EN 50 178) SELV (EN 60 950) VDE 0100-410
DIN VDE 0106-101 According to EN 61000-3-2
On horizontal NS 35 DIN rail according to EN 50022 ≥ 5 cm (1.969 in.) 0 cm IP 20 II, (in closed control cabinets) > 500 000 h according to IEC 1709 (SN 29 500) Polyamide PA, color green (45 x 99 x 114.5 mm [1.722 x 3.898 x 4.508 in.] 0.25 kg, approximately

<b>Climatic Data</b>	
Ambient temperature	Operation Storage
Humidity	
Vibration	according to IEC 68-2-6
Shock	according to IEC 68-2-27
Degree of pollution	
Climatic category	

-25°C to +70°C (-13°F to +158°F) (> +60°C [+140°F] derating) -40°C to +85°C (-40°F to +185°F) Up to 95% at +25°C (+77°F), no condensation < 15 Hz, amplitude ±2.5 mm/15 Hz - 150 Hz, 2.3 g 30 g all space directions 2 (according to EN 50 178) 3K3 (according to EN 60 721)
--

**CE  
Conforms to the EMC Directive 89/336/EEC and the  
Low Voltage Directive 73/23/EEC**

<sup>1)</sup> UL approval for ambient temperature up to +60 °C (+140 °C)

<b>EMC (Electromagnetic Compatibility) Noise Immunity According to EN 61000-6-2:</b>		
Electrostatic discharge (ESD)	EN 61000-4-2 <sup>3)</sup>	Housing Contact discharge: Air discharge:
Electromagnetic HF field	EN 61000-4-3 <sup>2)</sup>	Housing Frequency: Field strength:
Fast transients (burst)	EN 61000-4-4 <sup>3)</sup>	Input: Output:
Surge current loads	EN 61000-4-5 <sup>3)</sup>	Input: Output:
Conducted interference	EN 61000-4-6 <sup>2)</sup>	I/O: Frequency: U <sub>0</sub> :
Voltage dips	EN 61000-4-11 <sup>3)</sup>	Input:
Simulation of radiophone	EN 50204	Frequency: Field strength:

<b>Requirements EN 61 000-6-2</b>	<b>MINI-PS-100-240AC/10-15DC/2</b>	
4 kV 8 kV	> Level 3 8 kV 8 kV	
80 - 1000 MHz 10 V/m	Level 3 80 - 1000 MHz 10 V/m	
2 kV 2 kV	asymmetrical <sup>5)</sup> asymmetrical <sup>5)</sup>	4 kV (Level 4) 2 kV (Level 3)
2 kV 1 kV 0.5 kV 0.5 kV	asymmetrical <sup>5)</sup> symmetrical <sup>4)</sup> asymmetrical <sup>5)</sup> symmetrical <sup>4)</sup>	2 kV (Level 3) 1 kV (Level 3) 0.5 kV (Level 1) 0.5 kV (Level 1)
0.15 - 80 MHz 10 V	asymmetrical <sup>5)</sup>	Level 3 0.15 - 80 MHz 10 V
30% reduction of the input voltage for 0.5 periods		See input data: Mains buffering > 20 ms
Not required		900 MHz/1800 MHz 20 V/m

<b>Noise Emission According to EN 50081-2:</b>	
Radio interference	EN 55011
Radio interference	EN 55011

Class A <sup>6)</sup>	EN 55011 (EN 55022) Class B <sup>7)</sup>
Class A <sup>6)</sup>	EN 55011 (EN 55022) Class B <sup>7)</sup>

EN 55011 corresponds to CISPR11/EN 55022 corresponds to CISPR22  
EN 61000 corresponds to IEC 1000

<sup>2)</sup>Criterion A: Normal operating characteristics within the specified limits.  
<sup>3)</sup>Criterion B: Temporary adverse effects on the operating characteristics that the device corrects independently.

<sup>4)</sup>symmetrical: Cable to cable  
<sup>5)</sup>asymmetrical: Cable to ground  
<sup>6)</sup>Class A: Industrial application  
<sup>7)</sup>Class B: Industrial and domestic applications

## 4. Device View, Connections, and Control Elements

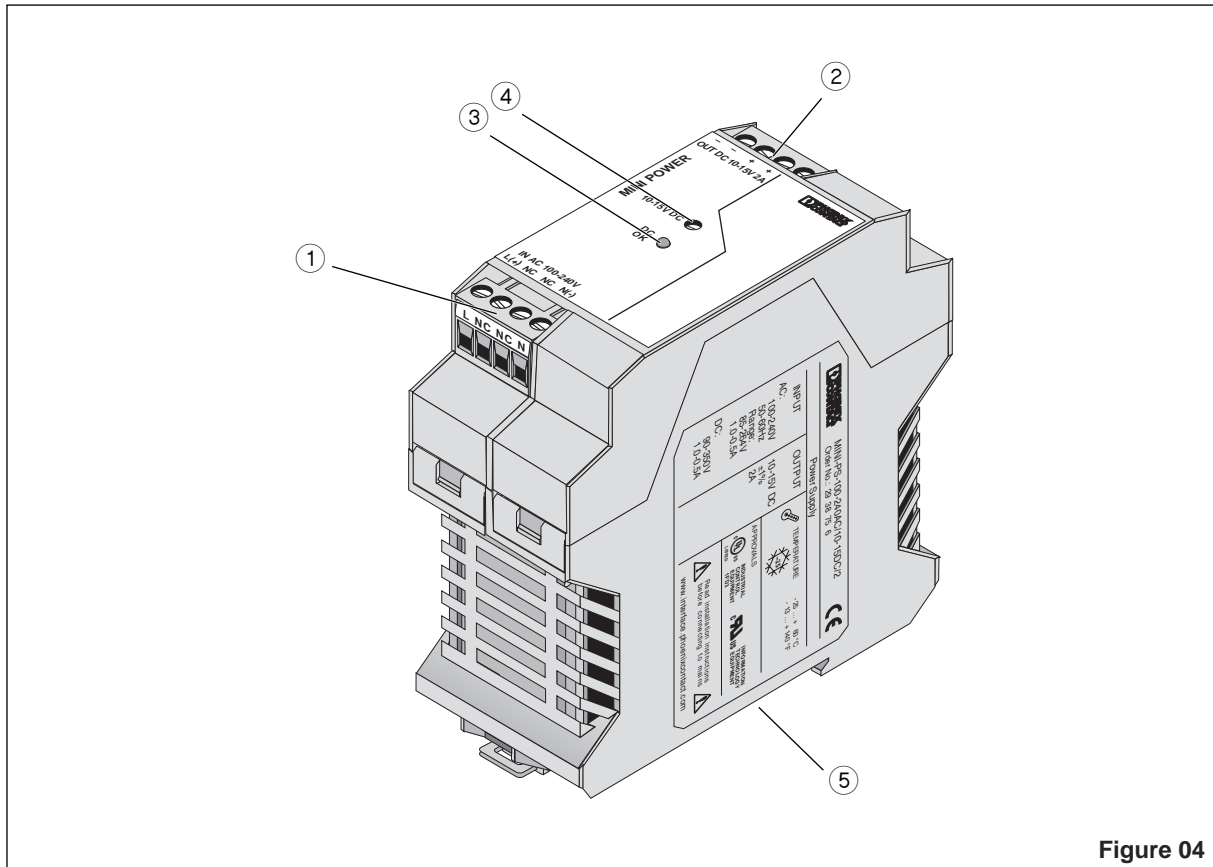

Figure 04

- ① **AC input:**  
 Input voltage 85 - 264 V AC  
 Frequency 45 - 65 Hz  
 (0.2 mm<sup>2</sup> to 2.5 mm<sup>2</sup> solid)  
 (0.2 mm<sup>2</sup> to 2.5 mm<sup>2</sup> flexible) (25 - 14 AWG)  
 Internal fuse 2 AT  
 Recommended fuse  
 10 A or 16 A c.b./Characteristic B
- ② **DC output:**  
 Output voltage 12 V DC (default),  
 can be set from 10 - 15 V DC using potentiometer ④  
 (0.2 mm<sup>2</sup> to 2.5 mm<sup>2</sup> solid)  
 (0.2 mm<sup>2</sup> to 2.5 mm<sup>2</sup> flexible) (25 - 14 AWG)  
 The device is idling-proof and short-circuit-proof.
- ③ **DC OK LED**
- ④ **Potentiometer 10 - 15 V DC**
- ⑤ **Universal latching foot for EN DIN rails**

**Installation and startup** must only be carried out by qualified personnel. The relevant country-specific regulations (e.g., VDE, DIN) must also be observed.

Before startup it is particularly important to ensure that:

- The mains have been connected correctly and protection is provided against electric shock.
- The device can be switched off outside the power supply according to EN 60950 regulations (e.g., by the line protection on the primary side).
- All supply lines have sufficient fuse protection and are the correct size.
- All output cables are the correct size for the maximum device output current or have separate fuse protection.
- Sufficient convection is ensured.

MINI POWER is a built-in device. After installation the terminal area must be covered to provide sufficient protection against unauthorized access to live parts. This is ensured by installing the device in the control cabinet or distributor box.

**The device contains dangerous live components and high levels of stored energy.**

## 5. Safety and Warning Instructions

To ensure that the device can be operated safely and all functions can be used, please read these instructions carefully.



**Caution: Never carry out work when the power is turned on, this is highly dangerous.**

## 6. Installation

### 6.1. Mounting

The power supply can be snapped onto all DIN rails according to EN 50022-35. The device must be mounted horizontally (input terminal blocks facing downwards).

#### Installation Dimensions



To ensure sufficient convection, we recommend a minimum spacing of 5 cm (1.969 in.) to other modules above and below the device.

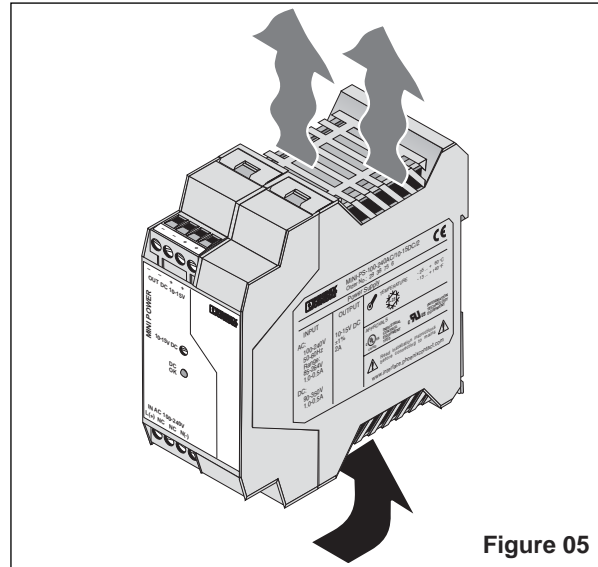

Figure 05

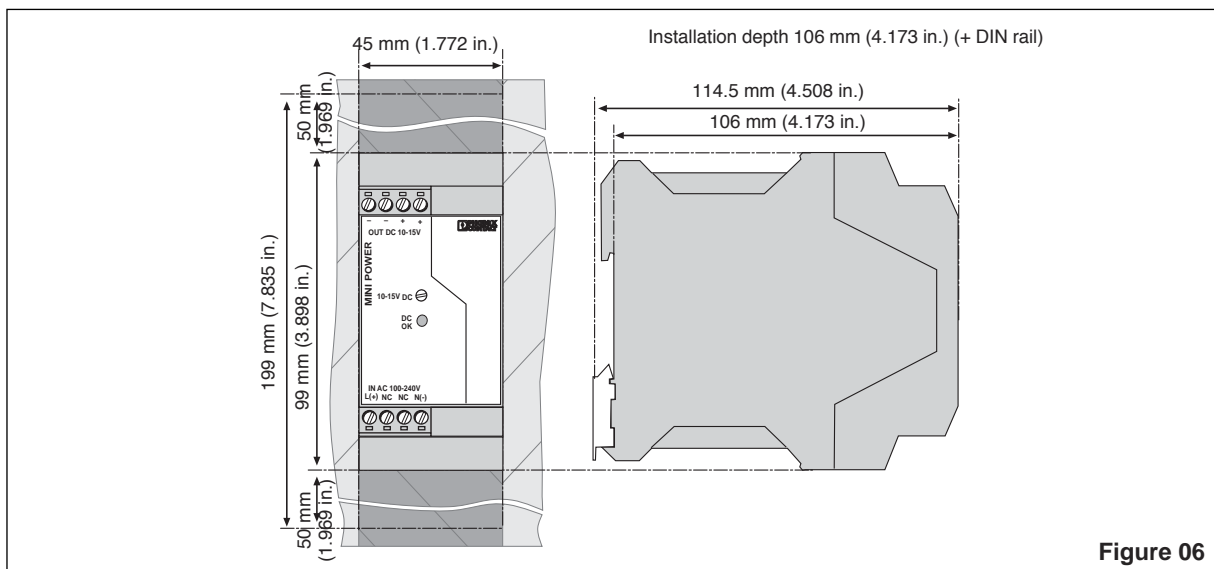

Figure 06

#### Mounting:

Place the module with the DIN rail guideway on the **top edge** of the DIN rail and then snap it **downwards**.

#### Removal:

Release the snap-on catch using a screwdriver and then detach the module from the **bottom edge** of the DIN rail.

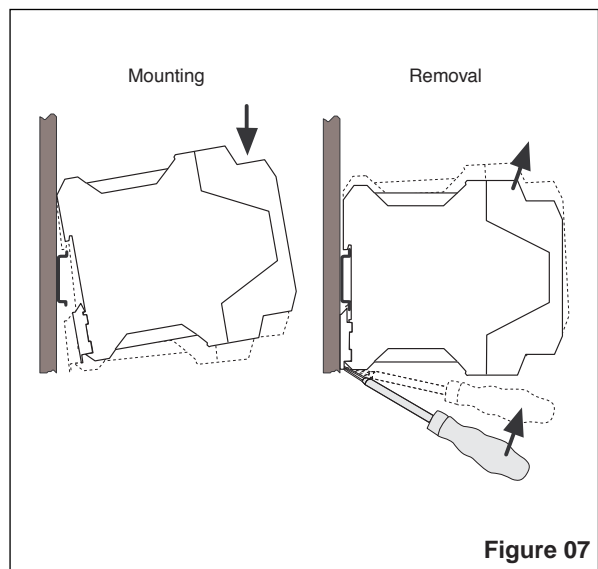
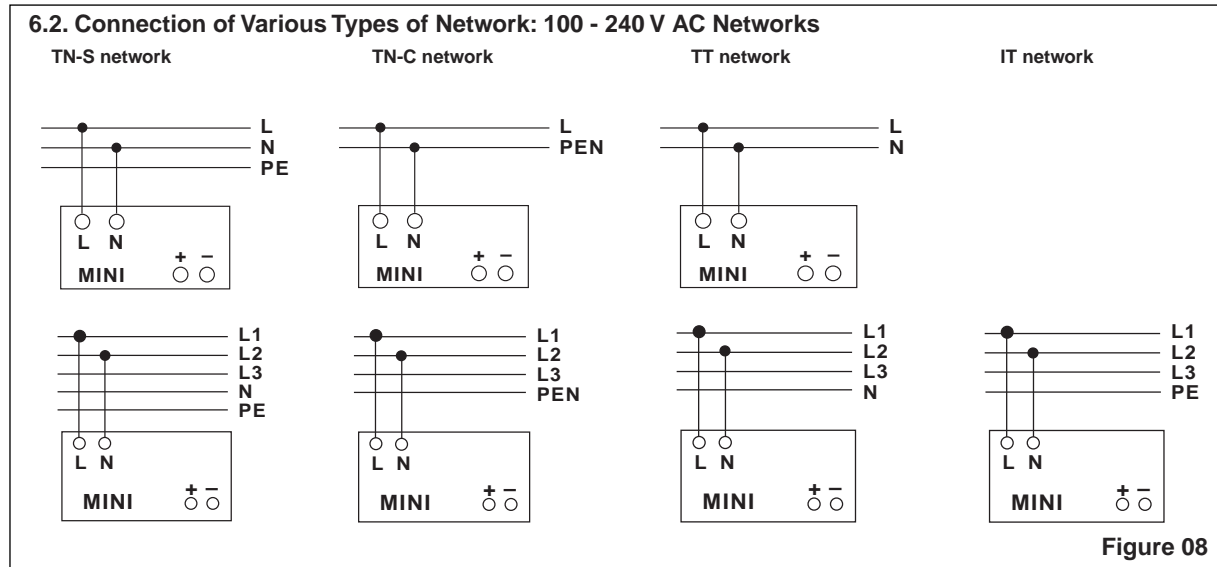

Figure 07



**Connection Cable:**

The device is equipped with COMBICON connectors. This reliable user-friendly connection method enables quick device connection and safe isolation of the electrical connection, if required. **Only operate connectors when the power is switched off.**

The following cable cross sections can be connected:

	Solid [mm <sup>2</sup> ]	Flexible [mm <sup>2</sup> ]	AWG	Torque [Nm]	Torque [lb in.]
① Input:	0.2 - 2.5	0.2 - 2.5	25 - 14	0.5 - 0.6	4.4 - 5.3
② Output:	0.2 - 2.5	0.2 - 2.5	25 - 14	0.5 - 0.6	4.4 - 5.3

**For reliable and safe-to-touch connection:** Strip 7 mm (0.28 in.) from the connector ends.

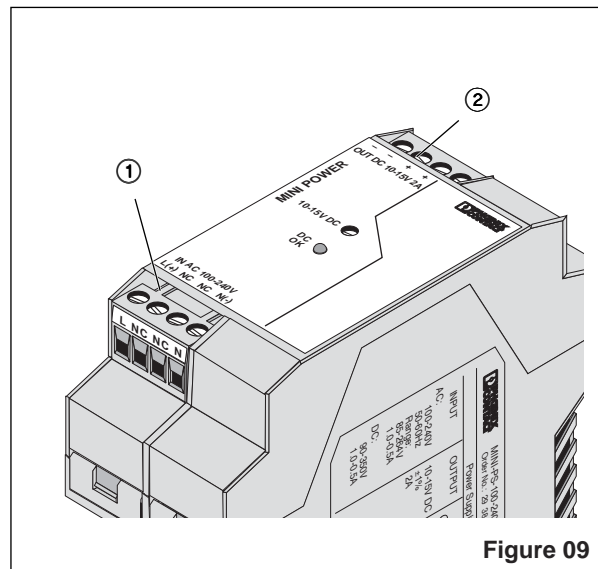
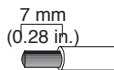

A suitable fuse must be fitted for DC applications.

**If the internal fuse is blown, this is most probably due to a device fault. In this case, the device should be checked in the factory.**

**6.3. Input (①, Figure 9)**

The 100 - 240 V AC connection is made using screw connections L and N. The device can be connected to single-phase AC networks or to two external conductors for three-phase networks (TN, TT or IT network according to VDE 0100 T300/IEC364-3) with nominal voltages of 100 - 240 V AC.

**Protecting the Primary Side**

The device must be installed according to the specifications of EN 60 950. It must be possible to switch off the device using a suitable disconnecting device outside the power supply.

Note that an all-pole disconnecting device must be provided for two-phase operation using two external conductors for a three-phase network.

For example, primary side line protection could be used.

Additional device protection is not required, as an internal fuse is present.

**Recommended Fuse:**

Circuit breaker 6 A or 10 A, Characteristic B (or equivalent).

#### 6.4. Output (②, Figure 9)

The 10 - 15 V DC connection is made using the "+" and "-" screw connections on the screw connection ②.

#### Protecting the Secondary Side:

The device is electronic short-circuit-proof and idling-proof. In the event of an error, the output voltage is limited to a maximum of 20 V DC.

It should be ensured that all output cables are the correct size for the maximum output current or have separate fuse protection.

The secondary side cables should have large cross sections to keep voltage drops on the cables to a minimum.

#### DC OK LED

The green DC OK LED enables local function evaluation in the control cabinet.

<b>LED ON</b>	Normal operation of the power supply
<b>LED OFF</b>	<p>a) The output voltage is <math>\leq 0.9 \times U_N</math>. There is a secondary load short circuit or overload outside the POWER BOOST area.</p> <p>b) No mains voltage is present or there is a device fault.</p>

## 7. Function

### 7.1. Output Characteristic Curve (Figure 10).

The device can supply a nominal output current of 2 A up to an ambient temperature of 60°C (140°F). With an ambient temperature of up to 40°C (104°F) the device continuously supplies an output current of 2.3 A. At temperatures up to 60°C (140°F), the POWER BOOST provides a short-term output current of 2.3 A for a few minutes.

With high loads, the working point demonstrates the U/I characteristic curve shown in Figure 10.

On an overload or short circuit, the entire output current  $I_{BOOST}$  is provided permanently at a reduced output voltage.

Once the overload or short circuit has been removed, the entire set secondary voltage is available again.

The U/I characteristic curve ensures that both heavy capacitive loads and devices with DC/DC converters can be supplied by MINI POWER in the input circuit without any problems.

Connected fuses are reliably tripped. The selectivity in your system configuration is ensured at all times.

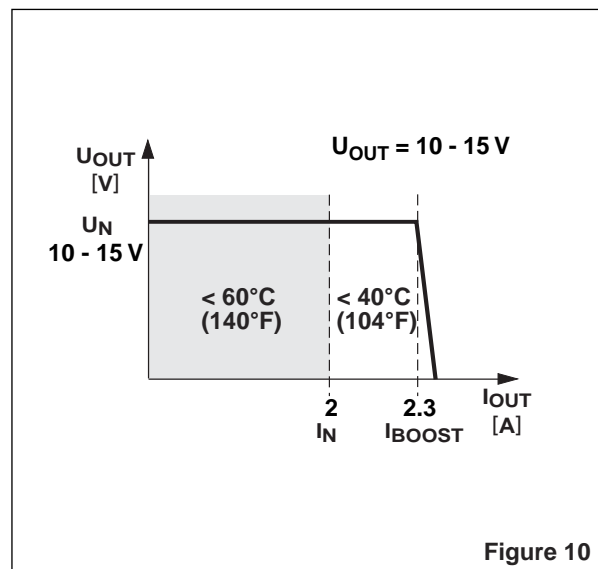

Figure 10

### 7.2. Temperature Response

The device can supply a nominal output current of 4 A up to an ambient temperature of 60°C (140°F). With an ambient temperature of up to 40°C (104°F) the device continuously supplies an output current of 5 A. At temperatures up to 60°C (140°F), the POWER BOOST provides a short-term output current of 6 A for a few minutes.

The output power must be decreased by 5% per Kelvin temperature increase for ambient temperatures above +60°C (+140°F). At ambient temperatures above +70°C (+158°F) or in the event of a thermal overload, the device reduces the output power to protect itself and returns to normal operation once it has cooled down.

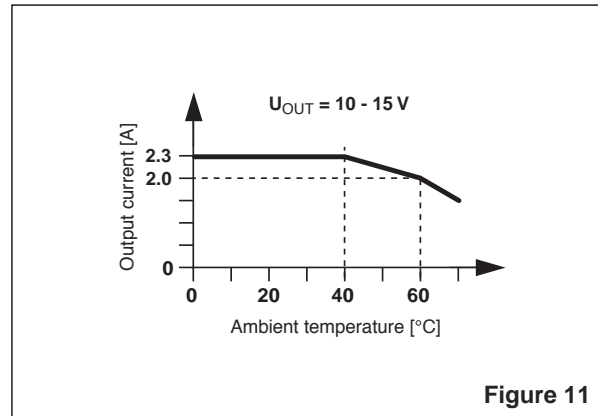

Figure 11

### 7.3. Parallel Operation

Devices of the same type can be connected in parallel to increase both redundancy and power. The default setting does not have to be adjusted.

To ensure symmetrical current distribution we recommend that all cable connections from the power supply to the DIN rail are the same length and have the same cross section.

Depending on the system, for parallel connection of more than two power supplies a protective circuit should be installed at each individual device output (e.g., decoupling diode or DC fuse). This means that in the event of a secondary device fault high return currents are avoided.

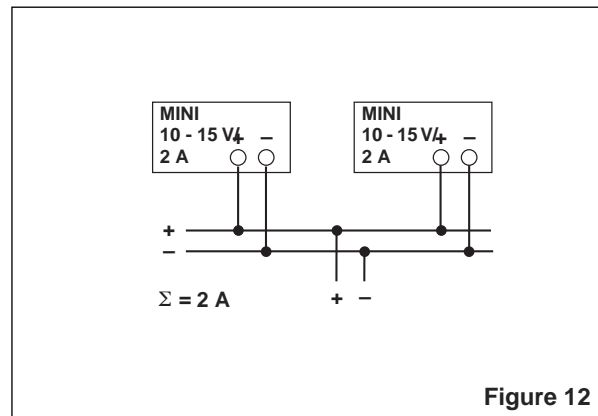

Figure 12

### 7.4. Redundancy Operation

Redundant connections are designed for supplying systems, which place particularly high requirements on operational safety. If a fault occurs in the primary circuit of device 1, device 2 automatically takes over the complete power supply without interruption and vice versa.

For this purpose, the power supplies to be connected in parallel must be large enough that the total current requirements of all loads can be fully met by one power supply. External decoupling diodes are required for 100% redundancy.

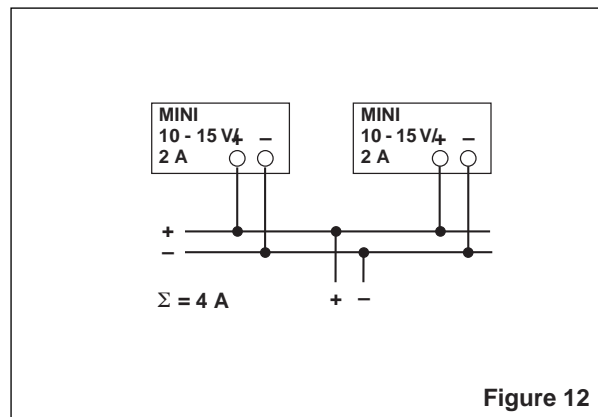

Figure 12

### 7.5. Power Increase

The output current can be increased to  $n \times I_N$  where  $n$  is the number of devices connected in parallel.

The parallel connection for power increase can be used to extend existing systems. A parallel connection is recommended if the power supply does not cover the current consumption of the most powerful load. Otherwise, the loads should be divided over independent individual devices.

A maximum of five devices can be connected in parallel.



Компания «Life Electronics» занимается поставками электронных компонентов импортного и отечественного производства от производителей и со складов крупных дистрибьюторов Европы, Америки и Азии.

С конца 2013 года компания активно расширяет линейку поставок компонентов по направлению коаксиальный кабель, кварцевые генераторы и конденсаторы (керамические, пленочные, электролитические), за счёт заключения дистрибьюторских договоров

Мы предлагаем:

- Конкурентоспособные цены и скидки постоянным клиентам.
- Специальные условия для постоянных клиентов.
- Подбор аналогов.
- Поставку компонентов в любых объемах, удовлетворяющих вашим потребностям.
- Приемлемые сроки поставки, возможна ускоренная поставка.
- Доставку товара в любую точку России и стран СНГ.
- Комплексную поставку.
- Работу по проектам и поставку образцов.
- Формирование склада под заказчика.
- Сертификаты соответствия на поставляемую продукцию (по желанию клиента).
- Тестирование поставляемой продукции.
- Поставку компонентов, требующих военную и космическую приемку.
- Входной контроль качества.
- Наличие сертификата ISO.

В составе нашей компании организован Конструкторский отдел, призванный помогать разработчикам, и инженерам.

Конструкторский отдел помогает осуществить:

- Регистрацию проекта у производителя компонентов.
- Техническую поддержку проекта.
- Защиту от снятия компонента с производства.
- Оценку стоимости проекта по компонентам.
- Изготовление тестовой платы монтаж и пусконаладочные работы.



Тел: +7 (812) 336 43 04 (многоканальный)

Email: [org@lifeelectronics.ru](mailto:org@lifeelectronics.ru)