

## Cmod™ Board Reference Manual

Revised October 26, 2012  
 This manual applies to the Cmod rev. D

### Overview

Cmod boards combine a Xilinx CPLD, a JTAG programming port, and power supply circuits in a convenient 600-mil, 40-pin DIP package. Cmods are ideally suited for breadboard or other prototype circuit designs where the use of small surface mount packages is impractical. All Cmod boards include:



The Cmod board.

Features include:

- A single 3.3V supply voltage (voltage regulation provided on Cmod board where required);
- Adequate bypass capacitance on all CPLD voltage supply pins;
- All available user I/O signals brought out to DIP pins;
- Once programmed, CPLD designs are non-volatile;
- Designs can easily be ported between Cmods using different CPLD device families;
- All Cmod boards are compatible with the free Xilinx WebPack tools.

Cmods were created to make the latest Xilinx CPLDs more practical for experimental and prototype circuits. They can plug directly in to breadboards or IC sockets, and they can mate with the Digilent Ceres™ board to utilize a collection of ready-made I/O circuits. Cmods are available with CoolRunner-II CPLD C2. C-Mod boards are especially useful for investigating designs across a variety of CPLD families.

## 1 Functional Description

Cmod boards, which measure just 0.7" by 2.16", allow designers to experiment with CPLD-based designs in a variety of state-of-the-art devices. Designs can easily be ported from one Cmod to another, so that design performance in different devices can be compared and contrasted. The 40-pin DIP form factor allows Cmods to be used in breadboard or other through-hole circuits where surface-mount devices are impractical. They can be configured with a wide range logic circuits, from simple logic functions to sequential controllers. All available CPLD I/O signals are routed to the 40-pin DIP connections.

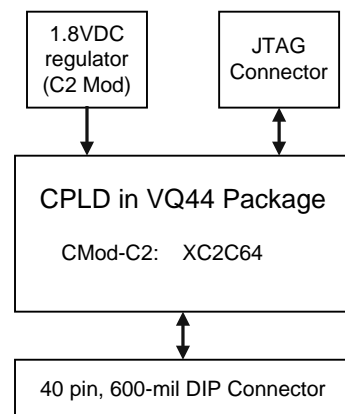

Figure 2. Cmod circuit board block diagram.

When used in conjunction with the Ceres board, Cmods can be used to rapidly implement CPLD based circuits, or to gain exposure to Xilinx CAD tools and CPLD-oriented design methods. The Ceres board provides Cmods with a power supply, a clock source, input buttons and switches, and various output LEDs. The Ceres/Cmod combination makes an excellent platform for use in teaching labs.

Cmods are programmed with a sample design during manufacturing. This design, available at the Digilent website, can be used to verify Cmod/Ceres function. It also provides a simple reference design example of a Xilinx project.

### 3 CPLD Configuration

Cmod boards contain a JTAG port for CPLD programming. The port consists of a pattern of six offset holes that are not loaded with header pins. To use this port, a row of six unattached header pins can be inserted into the end of a JTAG3 (or other) cable, and the other side of the header can be inserted into the offset hole patterns. Once the Cmod board is connected to the PC via the JTAG cable, the configuration software will automatically detect the CPLD.

JTAG Signal	XC2C64 pin	XC9572XL pin	XCR3064 pin
TCK	11	11	26
TDI	9	9	1
TDO	24	24	32
TMS	10	10	7

Table 1. CPLD JTAG pins.

To configure the board from a computer using the JTAG port, first ensure the Cmod is powered with a 3.3V supply (such as provided by the Ceres board), and that the JTAG cable is properly connected to the Cmod and to the computer. Start the configuration program (e.g., the iMPACT programmer available in the Xilinx WebPack tools), and the board will be auto-detected. Device programming and other JTAG operations are available in a pull-down menu made visible by right clicking on the device graphic in the programmer window.

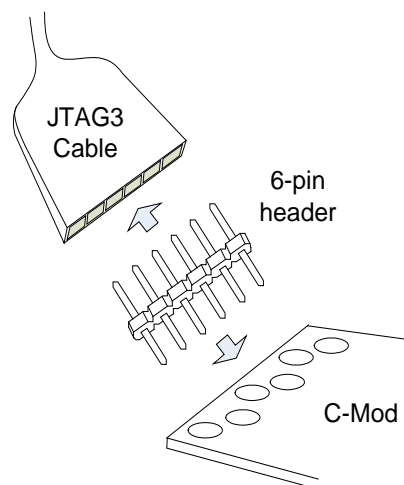

Figure 3. JTAG cable used with Cmod.

## 4 Power Supplies

Cmod boards require a single 3.3V supply on pin 20, and a single GND on pin 21. Current consumption is dependent on CPLD family, CPLD configuration, and external circuits. In most cases, current will be far less than 100mA, but the Xilinx data sheets for the particular CPLD should be referenced for more information.

## 5 CPLDs

Cmod boards are available with CoolRunner-2, CoolRunner (XPLA), and XC95 CPLDs. All available CPLD I/O signals are routed to the DIP connector, and the JTAG signals are routed to a programming connector. CPLD pinouts are provided in tables 2 and 3 below. Please see the data sheets for the CPLDs available at the Xilinx website for more information.

DIP PIN	Ceres Signal	C-Mod C2			C-Mod 95			C-Mod XCR		
		XC2C64 pin	type	Function Block	XC9572XL pin	type	Function Block	XCR3064 pin	type	Function Block
1	CA	12	IO	4	12	IO	3	12	IO	4
2	CB	13	IO	4	13	IO	3	13	IO	4
3	CC	14	IO	4	14	IO	3	14	IO	4
4	CD	16	IO	4	16	IO	3	15	IO	4
5					7	IO	3			
6										
7										
8										
9	CE	18	IO	3	18	IO	3	18	IO	3
10	CF	19	IO	3	19	IO	4	19	IO	3
11	CG	20	IO	3	20	IO	4	20	IO	3
12	AN3	21	IO	3	21	IO	4	21	IO	3
13	AN2	22	IO	3	22	IO	4	22	IO	3
14	AN1	23	IO	3	23	IO	4	23	IO	3
15	AN0	27	IO	3	27	IO	4	25	IO	3
16	SW7	28	IO	3	28	IO	4	27	IO	1
17	DP	29	IO	3	29	IO	2			
18	BTN3	30	GSR	1	30	IO	2	6	IO	2
19										
20		15	VCC		26	VCCIO		9,17,29, 41	VCC	
20		7,26	VCCIO		15,35	VCCINT				
20		35	VAUX							
21		4,17,25	GND		4,17,25	GND		16,24,36	GND	
22	SW6	31	GTS2	1	31	IO	2	28	IO	1
23	SW5	32	GTS3	1	32	IO	2	30	IO	1
24	SW4	33	GTS0	1	33	GSR	1	31	IO	1
25	SW3	34	GTS1	1	34	GTS2	2	33	IO	1
26	SW2	36	IO	1	36	GTS1	2	34	IO	1
27	SW1	37	IO	1	37	IO	2	35	IO	1

28	BTN2	38	IO	1	38	IO	2	37	IN3/CLK3	
29	SW0	39	IO	2	39	IO	1	42	IO	2
30	LED7	40	IO	2	40	IO	1	43	IO	2
31	LED6	41	IO	2	41	IO	1	44	IO	2
32	LED5	42	IO	2	42	IO	1	2	IO	2
33	BTN0	43	GCK0	2	43	GCK1	1	40	IN0/CLK0	
34	BTN1	44	GCK1	2	44	GCK2	1	39	IN1/CLK1	
35	MCLK	1	GCK2	2	1	GCK3	1	38	IN2/CLK2	
36	LED4	2	IO	2	2	IO	1	3	IO	2
37	LED3	3	IO	2	3	IO	1	5	IO	2
38	LED2	5	IO	4	5	IO	3	8	IO	4
39	LED1	6	IO	4	6	IO	3	10	IO	4
40	LED0	8	IO	4	8	IO	3	11	IO	4

Компания «Life Electronics» занимается поставками электронных компонентов импортного и отечественного производства от производителей и со складов крупных дистрибьюторов Европы, Америки и Азии.

С конца 2013 года компания активно расширяет линейку поставок компонентов по направлению коаксиальный кабель, кварцевые генераторы и конденсаторы (керамические, пленочные, электролитические), за счёт заключения дистрибьюторских договоров

Мы предлагаем:

- Конкурентоспособные цены и скидки постоянным клиентам.
- Специальные условия для постоянных клиентов.
- Подбор аналогов.
- Поставку компонентов в любых объемах, удовлетворяющих вашим потребностям.
- Приемлемые сроки поставки, возможна ускоренная поставка.
- Доставку товара в любую точку России и стран СНГ.
- Комплексную поставку.
- Работу по проектам и поставку образцов.
- Формирование склада под заказчика.
- Сертификаты соответствия на поставляемую продукцию (по желанию клиента).
- Тестирование поставляемой продукции.
- Поставку компонентов, требующих военную и космическую приемку.
- Входной контроль качества.
- Наличие сертификата ISO.

В составе нашей компании организован Конструкторский отдел, призванный помогать разработчикам, и инженерам.

Конструкторский отдел помогает осуществить:

- Регистрацию проекта у производителя компонентов.
- Техническую поддержку проекта.
- Защиту от снятия компонента с производства.
- Оценку стоимости проекта по компонентам.
- Изготовление тестовой платы монтаж и пусконаладочные работы.



Тел: +7 (812) 336 43 04 (многоканальный)

Email: [org@lifeelectronics.ru](mailto:org@lifeelectronics.ru)