

Si5368

Functional Block Diagram

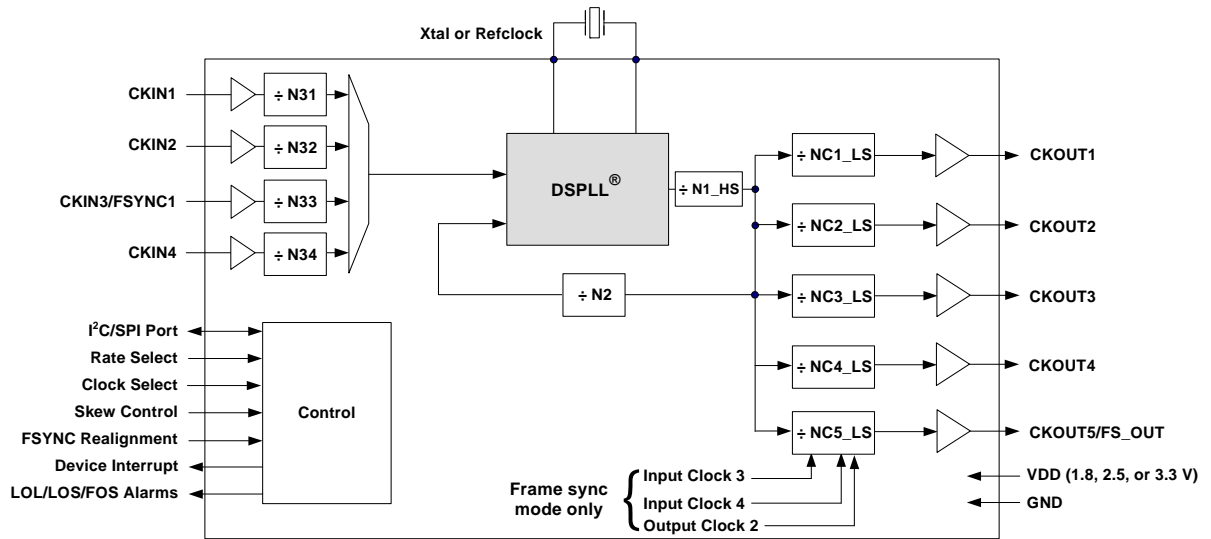

TABLE OF CONTENTS

<u>Section</u>	<u>Page</u>
1. Electrical Specifications	4
2. Typical Phase Noise Performance	17
3. Typical Application Circuits	18
4. Functional Description	20
4.1. External Reference	20
4.2. Further Documentation	21
5. Register Map	22
6. Register Descriptions	25
7. Pin Descriptions: Si5368	79
8. Ordering Guide	86
9. Package Outline: 100-Pin TQFP	87
10. Recommended PCB Layout	88
11. Top Marking: 100-Pin TQFP	90
11.1. Si5368 Top Marking	90
11.2. Top Marking Explanation	90
Document Change list	91
Contact Information	92

1. Electrical Specifications

Table 1. Recommended Operating Conditions¹

Parameter	Symbol	Test Condition	Min	Typ	Max	Unit
Ambient Temperature	T_A		-40	25	85	C
Supply Voltage during Normal Operation	V_{DD}	3.3 V Nominal ²	2.97	3.3	3.63	V
		2.5 V Nominal	2.25	2.5	2.75	V
		1.8 V Nominal	1.71	1.8	1.89	V

Notes:

- All minimum and maximum specifications are guaranteed and apply across the recommended operating conditions. Typical values apply at nominal supply voltages and an operating temperature of 25 °C unless otherwise stated.
- The LVPECL and CMOS output formats draw more current than either LVDS or CML; however, there are restrictions in the allowed output format pin settings so that the maximum power dissipation for the TQFP devices is limited when they are operated at 3.3 V. When there are four enabled LVPECL or CMOS outputs, the fifth output must be disabled. When there are five enabled outputs, there can be no more than three outputs that are either LVPECL or CMOS.

Table 2. DC Characteristics

($V_{DD} = 1.8 \pm 5\%$, $2.5 \pm 10\%$, or $3.3 \text{ V} \pm 10\%$, $T_A = -40$ to $85 \text{ }^\circ\text{C}$)

Parameter	Symbol	Test Condition	Min	Typ	Max	Unit
Supply Current ^{1,6}	I_{DD}	LVPECL Format 622.08 MHz Out All CKOUTs Enabled	—	394	435	mA
		LVPECL Format 622.08 MHz Out 1 CKOUT Enabled	—	253	284	mA
		CMOS Format 19.44 MHz Out All CKOUTs Enabled	—	278	400	mA
		CMOS Format 19.44 MHz Out 1 CKOUT Enabled	—	229	261	mA
		Disable Mode	—	165	—	mA

Notes:

- Current draw is independent of supply voltage
- No under- or overshoot is allowed.
- LVPECL outputs require nominal $V_{DD} \geq 2.5 \text{ V}$.
- This is the amount of leakage that the 3-Level inputs can tolerate from an external driver. See Si53xx Family Reference Manual for more details.
- LVPECL, CML, LVDS and low-swing LVDS measured with $F_o = 622.08 \text{ MHz}$.
- The LVPECL and CMOS output formats draw more current than either LVDS or CML; however, there are restrictions in the allowed output format pin settings so that the maximum power dissipation for the TQFP devices is limited when they are operated at 3.3 V. When there are four enabled LVPECL or CMOS outputs, the fifth output must be disabled. When there are five enabled outputs, there can be no more than three outputs that are either LVPECL or CMOS.

Table 2. DC Characteristics (Continued) $(V_{DD} = 1.8 \pm 5\%, 2.5 \pm 10\%, \text{ or } 3.3 \text{ V} \pm 10\%, T_A = -40 \text{ to } 85 \text{ } ^\circ\text{C})$

Parameter	Symbol	Test Condition	Min	Typ	Max	Unit
CKINn Input Pins²						
Input Common Mode Voltage (Input Threshold Voltage)	V_{ICM}	1.8 V \pm 5%	0.9	—	1.4	V
		2.5 V \pm 10%	1	—	1.7	V
		3.3 V \pm 10%	1.1	—	1.95	V
Input Resistance	CKN_{RIN}	Single-ended	20	40	60	k Ω
Single-Ended Input Voltage Swing (See Absolute Specs)	V_{ISE}	$f_{CKIN} < 212.5 \text{ MHz}$ See Figure 1.	0.2	—	—	V_{PP}
		$f_{CKIN} > 212.5 \text{ MHz}$ See Figure 1.	0.25	—	—	V_{PP}
Differential Input Voltage Swing (See Absolute Specs)	V_{ID}	$f_{CKIN} < 212.5 \text{ MHz}$ See Figure 1.	0.2	—	—	V_{PP}
		$f_{CKIN} > 212.5 \text{ MHz}$ See Figure 1.	0.25	—	—	V_{PP}
Output Clocks (CKOUTn)^{3,5,6}						
Common Mode	CKO_{VCM}	LVPECL 100 Ω load line-to-line	$V_{DD} - 1.42$	—	$V_{DD} - 1.25$	V
Differential Output Swing	CKO_{VD}	LVPECL 100 Ω load line-to-line	1.1	—	1.9	V_{PP}
Single Ended Output Swing	CKO_{VSE}	LVPECL 100 Ω load line-to-line	0.5	—	0.93	V_{PP}
Differential Output Voltage	CKO_{VD}	CML 100 Ω load line-to-line	350	425	500	mV $_{PP}$
Common Mode Output Voltage	CKO_{VCM}	CML 100 Ω load line-to-line	—	$V_{DD} - 0.36$	—	V
Notes:						
<ol style="list-style-type: none"> 1. Current draw is independent of supply voltage 2. No under- or overshoot is allowed. 3. LVPECL outputs require nominal $V_{DD} \geq 2.5 \text{ V}$. 4. This is the amount of leakage that the 3-Level inputs can tolerate from an external driver. See Si53xx Family Reference Manual for more details. 5. LVPECL, CML, LVDS and low-swing LVDS measured with $F_o = 622.08 \text{ MHz}$. 6. The LVPECL and CMOS output formats draw more current than either LVDS or CML; however, there are restrictions in the allowed output format pin settings so that the maximum power dissipation for the TQFP devices is limited when they are operated at 3.3 V. When there are four enabled LVPECL or CMOS outputs, the fifth output must be disabled. When there are five enabled outputs, there can be no more than three outputs that are either LVPECL or CMOS. 						

Table 2. DC Characteristics (Continued) $(V_{DD} = 1.8 \pm 5\%, 2.5 \pm 10\%, \text{ or } 3.3 \text{ V} \pm 10\%, T_A = -40 \text{ to } 85 \text{ }^\circ\text{C})$

Parameter	Symbol	Test Condition	Min	Typ	Max	Unit
Differential Output Voltage	CKO _{VD}	LVDS 100 Ω load line-to-line	500	700	900	mV _{PP}
		Low Swing LVDS 100 Ω load line-to-line	350	425	500	mV _{PP}
Common Mode Output Voltage	CKO _{VCM}	LVDS 100 Ω load line-to-line	1.125	1.2	1.275	V
Differential Output Resistance	CKO _{RD}	CML, LVPECL, LVDS	—	200	—	Ω
Output Voltage Low	CKO _{VOLLH}	CMOS	—	—	0.4	V
Output Voltage High	CKO _{VOHLH}	$V_{DD} = 1.71 \text{ V}$ CMOS	$0.8 \times V_{DD}$	—	—	V
Output Drive Current (CMOS driving into CKO _{VOL} for output low or CKO _{VOH} for output high. CKOUT+ and CKOUT– shorted externally)	CKO _{IO}	ICMOS[1:0] =11 $V_{DD} = 1.8 \text{ V}$	—	7.5	—	mA
		ICMOS[1:0] =10 $V_{DD} = 1.8 \text{ V}$	—	5.5	—	mA
		ICMOS[1:0] =01 $V_{DD} = 1.8 \text{ V}$	—	3.5	—	mA
		ICMOS[1:0] =00 $V_{DD} = 1.8 \text{ V}$	—	1.75	—	mA
		ICMOS[1:0] =11 $V_{DD} = 3.3 \text{ V}$	—	32	—	mA
		ICMOS[1:0] =10 $V_{DD} = 3.3 \text{ V}$	—	24	—	mA
		ICMOS[1:0] =01 $V_{DD} = 3.3 \text{ V}$	—	16	—	mA
		ICMOS[1:0] =00 $V_{DD} = 3.3 \text{ V}$	—	8	—	mA

Notes:

1. Current draw is independent of supply voltage
2. No under- or overshoot is allowed.
3. LVPECL outputs require nominal $V_{DD} \geq 2.5 \text{ V}$.
4. This is the amount of leakage that the 3-Level inputs can tolerate from an external driver. See Si53xx Family Reference Manual for more details.
5. LVPECL, CML, LVDS and low-swing LVDS measured with $F_o = 622.08 \text{ MHz}$.
6. The LVPECL and CMOS output formats draw more current than either LVDS or CML; however, there are restrictions in the allowed output format pin settings so that the maximum power dissipation for the TQFP devices is limited when they are operated at 3.3 V. When there are four enabled LVPECL or CMOS outputs, the fifth output must be disabled. When there are five enabled outputs, there can be no more than three outputs that are either LVPECL or CMOS.

Table 2. DC Characteristics (Continued)(V_{DD} = 1.8 ± 5%, 2.5 ± 10%, or 3.3 V ± 10%, T_A = -40 to 85 °C)

Parameter	Symbol	Test Condition	Min	Typ	Max	Unit
2-Level LVCMOS Input Pins						
Input Voltage Low	V _{IL}	V _{DD} = 1.71 V	—	—	0.5	V
		V _{DD} = 2.25 V	—	—	0.7	V
		V _{DD} = 2.97 V	—	—	0.8	V
Input Voltage High	V _{IH}	V _{DD} = 1.89 V	1.4	—	—	V
		V _{DD} = 2.25 V	1.8	—	—	V
		V _{DD} = 3.63 V	2.5	—	—	V
Notes:						
<ol style="list-style-type: none"> 1. Current draw is independent of supply voltage 2. No under- or overshoot is allowed. 3. LVPECL outputs require nominal VDD ≥ 2.5 V. 4. This is the amount of leakage that the 3-Level inputs can tolerate from an external driver. See Si53xx Family Reference Manual for more details. 5. LVPECL, CML, LVDS and low-swing LVDS measured with Fo = 622.08 MHz. 6. The LVPECL and CMOS output formats draw more current than either LVDS or CML; however, there are restrictions in the allowed output format pin settings so that the maximum power dissipation for the TQFP devices is limited when they are operated at 3.3 V. When there are four enabled LVPECL or CMOS outputs, the fifth output must be disabled. When there are five enabled outputs, there can be no more than three outputs that are either LVPECL or CMOS. 						

Table 2. DC Characteristics (Continued)(V_{DD} = 1.8 ± 5%, 2.5 ± 10%, or 3.3 V ± 10%, T_A = -40 to 85 °C)

Parameter	Symbol	Test Condition	Min	Typ	Max	Unit
3-Level Input Pins⁴						
Input Voltage Low	V _{ILL}		—	—	0.15 x V _{DD}	V
Input Voltage Mid	V _{IMM}		0.45 x V _{DD}	—	0.55 x V _{DD}	V
Input Voltage High	V _{IHH}		0.85 x V _{DD}	—	—	V
Input Low Current	I _{ILL}	See Note 4	-20	—	—	μA
Input Mid Current	I _{IMM}	See Note 4	-2	—	+2	μA
Input High Current	I _{IHH}	See Note 4	—	—	20	μA
LVC MOS Output Pins						
Output Voltage Low	V _{OL}	IO = 2 mA V _{DD} = 1.71 V	—	—	0.4	V
Output Voltage Low		IO = 2 mA V _{DD} = 2.97 V	—	—	0.4	V
Output Voltage High	V _{OH}	IO = -2 mA V _{DD} = 1.71 V	V _{DD} - 0.4	—	—	V
Output Voltage High		IO = -2 mA V _{DD} = 2.97 V	V _{DD} - 0.4	—	—	V
Notes:						
<ol style="list-style-type: none"> 1. Current draw is independent of supply voltage 2. No under- or overshoot is allowed. 3. LVPECL outputs require nominal V_{DD} ≥ 2.5 V. 4. This is the amount of leakage that the 3-Level inputs can tolerate from an external driver. See Si53xx Family Reference Manual for more details. 5. LVPECL, CML, LVDS and low-swing LVDS measured with F_o = 622.08 MHz. 6. The LVPECL and CMOS output formats draw more current than either LVDS or CML; however, there are restrictions in the allowed output format pin settings so that the maximum power dissipation for the TQFP devices is limited when they are operated at 3.3 V. When there are four enabled LVPECL or CMOS outputs, the fifth output must be disabled. When there are five enabled outputs, there can be no more than three outputs that are either LVPECL or CMOS. 						

Table 3. AC Specifications(V_{DD} = 1.8 ± 5%, 2.5 ± 10%, or 3.3 V ± 10%, T_A = -40 to 85 °C)

Parameter	Symbol	Test Condition	Min	Typ	Max	Unit
Single-Ended Reference Clock Input Pin XA (XB with cap to GND)						
Input Resistance	XA _{RIN}	RATE[1:0] = LM, MH, ac coupled	—	12	—	kΩ
Input Voltage Swing	XA _{VPP}	RATE[1:0] = LM, MH, ac coupled	0.5	—	1.2	V _{PP}
Differential Reference Clock Input Pins (XA/XB)						
Input Voltage Swing	XA/XB _{VPP}	RATE[1:0] = LM, MH	0.5	—	2.4	V _{PP}
CKINn Input Pins						
Input Frequency	CKN _F	Input frequency and clock multiplication ratio determined by programming device PLL dividers. Consult Silicon Laboratories configuration software <i>DSPLLsim</i> or Any-Frequency Precision Clock Family Reference Manual at www.silabs.com/timing (click on Documentation) to determine PLL divider settings for a given input frequency/clock multiplication ratio combination	0.002	—	710	MHz
Input Clock Frequency (CKIN3, CKIN4 used as FSYNC inputs)	CK _F		0.002	—	0.512	MHz
Input Duty Cycle (Minimum Pulse Width)	CKN _{DC}	Whichever is smaller (i.e., the 40% / 60% limitation applies only to high frequency clocks)	40	—	60	%
			2	—	—	ns
Input Capacitance	CKN _{CIN}		—	—	3	pF
Input Rise/Fall Time	CKN _{TRF}	20–80% See Figure 2	—	—	11	ns
*Note: Input to output phase skew after an ICAL is not controlled and can assume any value.						

Table 3. AC Specifications (Continued)

($V_{DD} = 1.8 \pm 5\%$, $2.5 \pm 10\%$, or $3.3 V \pm 10\%$, $T_A = -40$ to $85\text{ }^\circ\text{C}$)

Parameter	Symbol	Test Condition	Min	Typ	Max	Unit
CKOUTn Output Pins						
(See ordering section for speed grade vs frequency limits)						
Output Frequency (Output not configured for CMOS or Disabled)	CKO _F	N1 ≥ 6	0.002	—	945	MHz
		N1 = 5	970	—	1134	MHz
		N1 = 4	1.213	—	1.4	GHz
Maximum Output Frequency in CMOS Format	CKO _F		—	—	212.5	MHz
Output Rise/Fall (20–80 %) @ 622.08 MHz output	CKO _{TRF}	Output not configured for CMOS or Disabled See Figure 2	—	230	350	ps
Output Rise/Fall (20–80%) @ 212.5 MHz output	CKO _{TRF}	CMOS Output $V_{DD} = 1.71$ $C_{LOAD} = 5\text{ pF}$	—	—	8	ns
Output Rise/Fall (20–80%) @ 212.5 MHz output	CKO _{TRF}	CMOS Output $V_{DD} = 2.97$ $C_{LOAD} = 5\text{ pF}$	—	—	2	ns
Output Duty Cycle Uncertainty @ 622.08 MHz	CKO _{DC}	100 Ω Load Line-to-Line Measured at 50% Point (Not for CMOS)	—	—	±40	ps
LVC MOS Input Pins						
Minimum Reset Pulse Width	t _{RSTMN}		1			μs
Reset to Microprocessor Access Ready	t _{READY}				10	ms
Input Capacitance	C _{in}		—	—	3	pF
LVC MOS Output Pins						
Rise/Fall Times	t _{RF}	C _{LOAD} = 20pf See Figure 2	—	25	—	ns
LOSn Trigger Window	LOS _{TRIG}	From last CKINn ↑ to ↓ Internal detection of LOSn N3 ≠ 1	—	—	4.5 x N3	T _{CKIN}
Time to Clear LOL after LOS Cleared	t _{CLRLOL}	↓LOS to ↓LOL Fold = Fnew Stable Xa/XB reference	—	10	—	ms
*Note: Input to output phase skew after an ICAL is not controlled and can assume any value.						

Table 3. AC Specifications (Continued) $(V_{DD} = 1.8 \pm 5\%, 2.5 \pm 10\%, \text{ or } 3.3 \text{ V} \pm 10\%, T_A = -40 \text{ to } 85 \text{ }^\circ\text{C})$

Parameter	Symbol	Test Condition	Min	Typ	Max	Unit
Device Skew						
Output Clock Skew	t_{SKEW}	\uparrow of CKOUT _n to \uparrow of CKOUT _m , CKOUT _n and CKOUT _m at same frequency and signal format PHASEOFFSET = 0 CKOUT_ALWAYS_ON = 1 SQ_ICAL = 1	—	—	100	ps
Phase Change due to Temperature Variation*	t_{TEMP}	Max phase changes from -40 to $+85$ $^\circ\text{C}$	—	300	500	ps
PLL Performance ($f_{\text{in}} = f_{\text{out}} = 622.08 \text{ MHz}$; BW = 120 Hz; LVPECL)						
Lock Time	t_{LOCKMP}	Start of ICAL to \downarrow of LOL	—	35	1200	ms
Output Clock Phase Change	$t_{\text{P_STEP}}$	After clock switch $f_3 \geq 128 \text{ kHz}$	—	200	—	ps
Closed Loop Jitter Peaking	J_{PK}		—	0.05	0.1	dB
Jitter Tolerance	J_{TOL}	Jitter Frequency \geq Loop Bandwidth	5000/BW	—	—	ns pk-pk
Phase Noise $f_{\text{out}} = 622.08 \text{ MHz}$	CKO _{PN}	1 kHz Offset	—	-106	—	dBc/Hz
		10 kHz Offset	—	-121	—	dBc/Hz
		100 kHz Offset	—	-132	—	dBc/Hz
		1 MHz Offset	—	-132	—	dBc/Hz
Spurious Noise	SP _{SPUR}	Max spur @ $n \times F_3$ ($n \geq 1, n \times F_3 < 100 \text{ MHz}$)	—	-93	-70	dBc

*Note: Input to output phase skew after an ICAL is not controlled and can assume any value.

Table 4. Microprocessor Control

($V_{DD} = 1.8 \pm 5\%$, $2.5 \pm 10\%$, or $3.3 \text{ V} \pm 10\%$, $T_A = -40$ to $85 \text{ }^\circ\text{C}$)

Parameter	Symbol	Test Condition	Min	Typ	Max	Unit
I²C Bus Lines (SDA, SCL)						
Input Voltage Low	$V_{IL_{I2C}}$		—	—	$0.25 \times V_{DD}$	V
Input Voltage High	$V_{IH_{I2C}}$		$0.7 \times V_{DD}$	—	V_{DD}	V
Hysteresis of Schmitt trigger inputs	$V_{HYS_{I2C}}$	$V_{DD} = 1.8\text{V}$	$0.1 \times V_{DD}$	—	—	V
		$V_{DD} = 2.5$ or 3.3 V	$0.05 \times V_{DD}$	—	—	V
Output Voltage Low	$V_{OL_{I2C}}$	$V_{DD} = 1.8 \text{ V}$ $I_O = 3 \text{ mA}$	—	—	$0.2 \times V_{DD}$	V
		$V_{DD} = 2.5$ or 3.3 V $I_O = 3 \text{ mA}$	—	—	0.4	V

Table 4. Microprocessor Control (Continued) $(V_{DD} = 1.8 \pm 5\%, 2.5 \pm 10\%, \text{ or } 3.3 \text{ V} \pm 10\%, T_A = -40 \text{ to } 85 \text{ }^\circ\text{C})$

Parameter	Symbol	Test Condition	Min	Typ	Max	Unit
SPI Specifications						
Duty Cycle, SCLK	t_{DC}	SCLK = 10 MHz	40	—	60	%
Cycle Time, SCLK	t_c		100	—	—	ns
Rise Time, SCLK	t_r	20–80%	—	—	25	ns
Fall Time, SCLK	t_f	20–80%	—	—	25	ns
Low Time, SCLK	t_{lsc}	20–20%	30	—	—	ns
High Time, SCLK	t_{hsc}	80–80%	30	—	—	ns
Delay Time, SCLK Fall to SDO Active	t_{d1}		—	—	25	ns
Delay Time, SCLK Fall to SDO Transition	t_{d2}		—	—	25	ns
Delay Time, SS Rise to SDO Tri-state	t_{d3}		—	—	25	ns
Setup Time, SS to SCLK Fall	t_{su1}		25	—	—	ns
Hold Time, SS to SCLK Rise	t_{h1}		20	—	—	ns
Setup Time, SDI to SCLK Rise	t_{su2}		25	—	—	ns
Hold Time, SDI to SCLK Rise	t_{h2}		20	—	—	ns
Delay Time between Slave Selects	t_{cs}		25	—	—	ns

Table 5. Jitter Generation

Parameter	Symbol	Test Condition*		Min	Typ	Max	GR-253-Specification	Unit
		Measurement Filter	DSPLL BW ²					
Jitter Gen OC-192	JGEN	0.02–80 MHz	120 Hz	—	4.2	6.2	30	ps _{pp}
				—	.27	0.42	N/A	ps _{rms}
		4–80 MHz	120 Hz	—	3.7	6.4	10	ps _{pp}
				—	.14	0.31	N/A	ps _{rms}
		0.05–80 MHz	120 Hz	—	4.4	6.9	10	ps _{pp}
				—	.26	0.41	1.0	ps _{rms}
Jitter Gen OC-48	JGEN	0.12–20 MHz	120 Hz	—	3.5	5.4	40.2	ps _{pp}
				—	.27	0.41	4.02	ps _{rms}

***Note:** Test conditions:

1. $f_{IN} = f_{OUT} = 622.08$ MHz
2. Clock input: LVPECL
3. Clock output: LVPECL
4. PLL bandwidth: 120 Hz
5. 114.285 MHz 3rd OT crystal used as XA/XB input
6. $V_{DD} = 2.5$ V
7. $T_A = 85$ °C
8. Jitter integration bands include low-pass (–20 dB/Dec) and hi-pass (–60 dB/Dec) roll-offs per Telecordia GR-253-CORE.

Table 6. Thermal Characteristics

($V_{DD} = 1.8 \pm 5\%$, $2.5 \pm 10\%$, or 3.3 V $\pm 10\%$, $T_A = -40$ to 85 °C)

Parameter	Symbol	Test Condition	Value	Unit
Thermal Resistance Junction to Ambient	θ_{JA}	Still Air	31	C°/W

Table 7. Absolute Maximum Limits

Parameter	Symbol	Test Condition	Min	Typ	Max	Unit
DC Supply Voltage	V_{DD}		-0.5	—	3.8	V
LVC MOS Input Voltage	V_{DIG}		-0.3		$V_{DD}+0.3$	V
CKINn Voltage Level Limits	CKN_{VIN}		0	—	V_{DD}	V
XA/XB Voltage Level Limits	XA_{VIN}		0	—	1.2	V
Operating Junction Temperature	T_{JCT}		-55	—	150	°C
Storage Temperature Range	T_{STG}		-55	—	150	°C
ESD HBM Tolerance (100 pF, 1.5 k Ω); All pins except CKIN+/CKIN-			2	—	—	kV
ESD MM Tolerance; All pins except CKIN+/CKIN-			150	—	—	V
ESD HBM Tolerance (100 pF, 1.5 k Ω); CKIN+/CKIN-			700	—	—	V
ESD MM Tolerance; CKIN+/CKIN-			100	—	—	V
Latch-up Tolerance			JESD78 Compliant			
Note: Permanent device damage may occur if the Absolute Maximum Ratings are exceeded. Functional operation should be restricted to the conditions specified in the operations sections of this data sheet. Exposure to absolute maximum rating conditions for extended periods of time may affect device reliability.						



Figure 1. Differential Voltage Characteristics

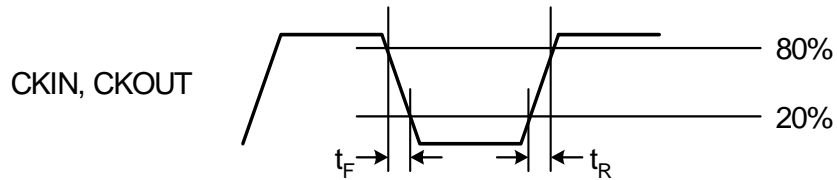

Figure 2. Rise/Fall Time Characteristics

2. Typical Phase Noise Performance



Figure 3. Typical Phase Noise Plot

Table 8. RMS Jitter by Band

Jitter Band	Jitter, RMS
SONET_OC48, 12 kHz to 20 MHz	249 fs
SONET_OC192_A, 20 kHz to 80 MHz	274 fs
SONET_OC192_B, 4 MHz to 80 MHz	166 fs
SONET_OC192_C, 50 kHz to 80 MHz	267 fs
Brick Wall_800 Hz to 80 MHz	274 fs

***Note:** Jitter integration bands include low-pass (-20 dB/Dec) and hi-pass (-60 dB/Dec) roll-offs per Teledonia GR-253-CORE.

3. Typical Application Circuits



Figure 4. Si5368 Typical Application Circuit (I²C Control Mode)

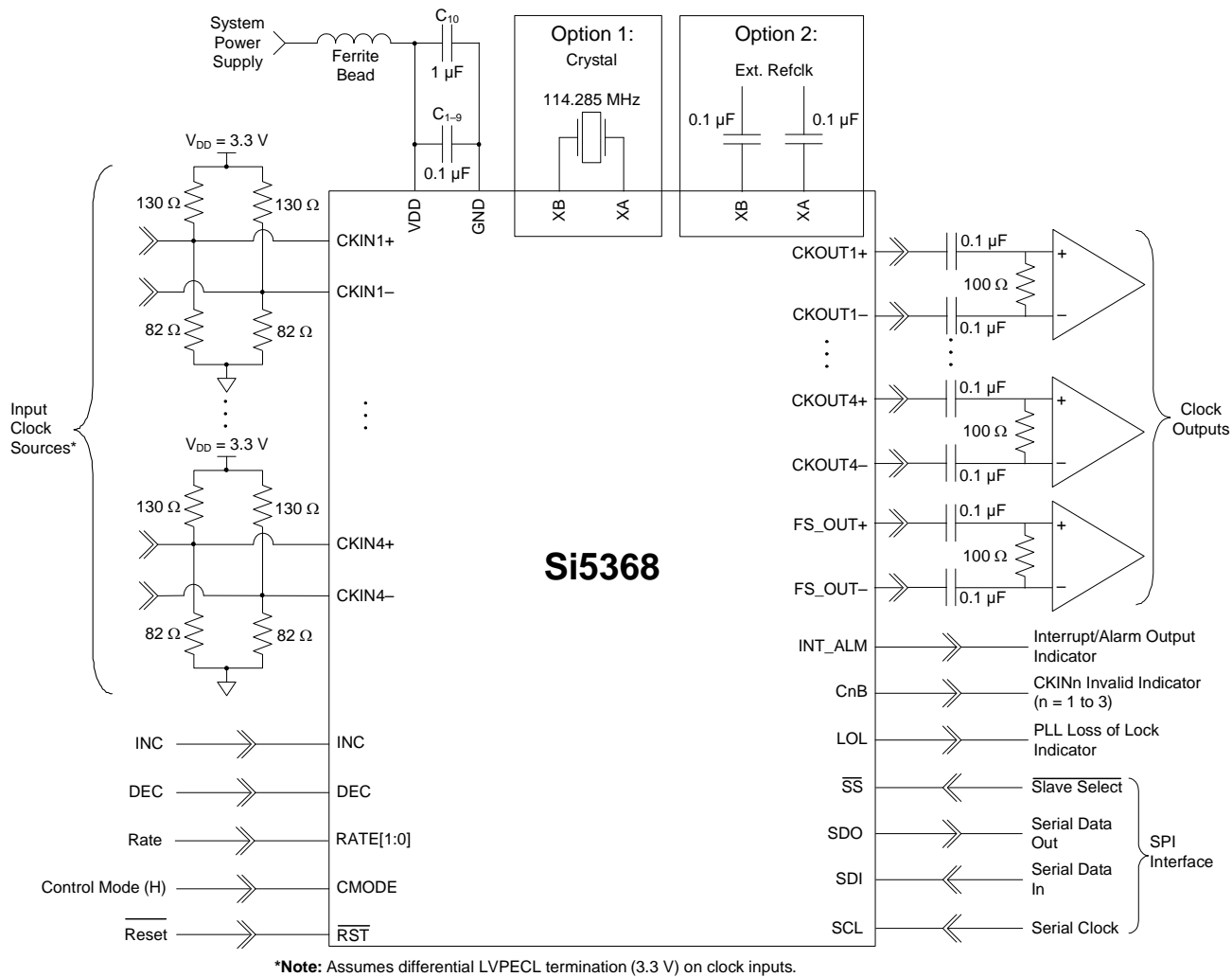

Figure 5. Si5368 Typical Application Circuit (SPI Control Mode)

4. Functional Description

The Si5368 is a jitter-attenuating precision clock multiplier for applications requiring sub 1 ps rms jitter performance. The Si5368 accepts four clock inputs ranging from 2 kHz to 710 MHz and generates five clock outputs ranging from 2 kHz to 945 MHz and select frequencies to 1.4 GHz. The device provides virtually any frequency translation combination across this operating range. Independent dividers are available for every input clock and output clock, so the Si5368 can accept input clocks at different frequencies and it can generate output clocks at different frequencies. The Si5368 input clock frequency and clock multiplication ratio are programmable through an I²C or SPI interface. Optionally, the fifth clock output can be configured as a 2 to 512 kHz SONET/SDH frame synchronization output that is phase aligned with one of the high-speed output clocks. Silicon Laboratories offers a PC-based software utility, *DSPLLsim*, that can be used to determine the optimum PLL divider settings for a given input frequency/clock multiplication ratio combination that minimizes phase noise and power consumption. This utility can be downloaded from <http://www.silabs.com/timing> (click on Documentation).

The Si5368 is based on Silicon Laboratories' 3rd-generation DSPLL[®] technology, which provides any-frequency synthesis and jitter attenuation in a highly integrated PLL solution that eliminates the need for external VCXO and loop filter components. The Si5368 PLL loop bandwidth is digitally programmable and supports a range from 60 Hz to 8.4 kHz. The *DSPLLsim* software utility can be used to calculate valid loop bandwidth settings for a given input clock frequency/clock multiplication ratio.

The Si5368 supports hitless switching between input clocks in compliance with GR-253-CORE and GR-1244-CORE that greatly minimizes the propagation of phase transients to the clock outputs during an input clock transition (<200 ps tp). Manual, automatic revertive and non-revertive input clock switching options are available. The Si5368 monitors the four input clocks for loss-of-signal and provides a LOS alarm when it detects missing pulses on any of the four input clocks. The device monitors the lock status of the PLL. The lock detect algorithm works by continuously monitoring the phase of the input clock in relation to the phase of the feedback clock. The Si5368 monitors the frequency of CKIN1, CKIN2, CKIN3, and CKIN4 with respect to a selected reference frequency and generates a frequency offset alarm (FOS) if the threshold is exceeded. This FOS feature is available for SONET applications in which both the monitored frequency on CKIN1, CKIN3, and CKIN4 and the reference frequency are integer multiples of 19.44 MHz. Both Stratum 3/3E and SONET Minimum Clock (SMC) FOS thresholds are supported.

The Si5368 provides a digital hold capability that allows the device to continue generation of a stable output clock when the selected input reference is lost. During digital hold, the DSPLL generates an output frequency based on a historical average that existed a fixed amount of time before the error event occurred, eliminating the effects of phase and frequency transients that may occur immediately preceding digital hold.

Fine phase adjustment is available and is set using the FLAT register bits. The nominal range and resolution of the FLAT[14:0] latency adjustment word are: ± 110 ps and 3 ps, respectively.

The Si5368 has five differential clock outputs. The electrical format of the clock outputs is programmable to support LVPECL, LVDS, CML, or CMOS loads. If not required, unused clock outputs can be powered down to minimize power consumption. The phase difference between the selected input clock and the output clocks is adjustable in 200 ps increments for system skew control. In addition, the phase of one output clock may be adjusted in relation to the phase of the other output clock. The resolution varies from 800 ps to 2.2 ns depending on the PLL divider settings. Consult the *DSPLLsim* configuration software to determine the phase offset resolution for a given input clock/clock multiplication ratio combination. For system-level debugging, a bypass mode is available which drives the output clock directly from the input clock, bypassing the internal DSPLL. The device is powered by a single 1.8, 2.5, or 3.3 V supply.

4.1. External Reference

An external, 38.88 MHz clock or a low-cost 114.285 MHz 3rd overtone crystal is used as part of a fixed-frequency oscillator within the DSPLL. This external reference is required for the device to operate. Silicon Laboratories recommends using a high-quality crystal. Specific recommendations may be found in the Family Reference Manual. An external clock from a high-quality OCXO or TCXO can also be used as a reference for the device.

In digital hold, the DSPLL remains locked to this external reference. Any changes in the frequency of this reference when the DSPLL is in digital hold, will be tracked by the output of the device. Note that crystals can have temperature sensitivities.

4.2. Further Documentation

Consult the Silicon Laboratories Any-Frequency Precision Clock Family Reference Manual (FRM) for detailed information about the Si5368. Additional design support is available from Silicon Laboratories through your distributor.

Silicon Laboratories has developed a PC-based software utility called *DSPLLsim* to simplify device configuration, including frequency planning and loop bandwidth selection. The FRM and this utility can be downloaded from <http://www.silabs.com/timing>; click on Documentation.

5. Register Map

All register bits that are not defined in this map should always be written with the specified Reset Values. The writing to these bits of values other than the specified Reset Values may result in undefined device behavior. Registers not listed, such as Register 64, should never be written to.

Register	D7	D6	D5	D4	D3	D2	D1	D0
0		FREE_RUN	CKOUT_ALWAYS_ON		CK_CONFIG_REG		BYPASS_REG	
1	CK_PRIOR4 [1:0]		CK_PRIOR3 [1:0]		CK_PRIOR2 [1:0]		CK_PRIOR1 [1:0]	
2	BWSEL_REG [3:0]							
3	CKSEL_REG [1:0]		DHOLD	SQ_ICAL				
4	AUTOSEL_REG [1:0]			HIST_DEL [4:0]				
5	ICMOS [1:0]		SFOUT2_REG [2:0]			SFOUT1_REG [2:0]		
6			SFOUT4_REG [2:0]			SFOUT3_REG [2:0]		
7			SFOUT5_REG [2:0]			FOSREFSEL [2:0]		
8	HLOG_4 [1:0]		HLOG_3 [1:0]		HLOG_2 [1:0]		HLOG_1 [1:0]	
9	HIST_AVG [4:0]						HLOG_5 [1:0]	
10			DSBL5_REG		DSBL4_REG	DSBL3_REG	DSBL2_REG	DSBL1_REG
11	ALIGN_THR [2:0]				PD_CK4	PD_CK3	PD_CK2	PD_CK1
12	FPW_VALID	FSYNC_ALIGN_REG	FSYNC_ALIGN_MODE	FSYNC_SWTCH_REG	FSKEW_VALID	FSYNC_SKEW [16:16]	FSYNC_PW [9:8]	
13	FSYNC_PW [7:0]							
14	FSYNC_SKEW [15:8]							
15	FSYNC_SKEW [7:0]							
16	CLAT [7:0]							
17	FLAT_VALID	FLAT [14:8]						
18	FLAT [7:0]							
19	FOS_EN	FOS_THR [1:0]		VALTIME [1:0]		LOCKT [2:0]		
20			ALRMOUT_PIN	CK3_BAD_PIN	CK2_BAD_PIN	CK1_BAD_PIN	LOL_PIN	INT_PIN
21	INCDEC_PIN		FSYNC_ALIGN_PIN	CK4_ACTV_PIN	CK3_ACTV_PIN	CK2_ACTV_PIN	CK1_ACTV_PIN	CKSEL_PIN
22	FSYNC_ALIGN_POL	FSYNC_POL		FSYNCOUT_POL	CK_ACTV_POL	CK_BAD_POL	LOL_POL	INT_POL

Register	D7	D6	D5	D4	D3	D2	D1	D0
23				LOS4_MSK	LOS3_MSK	LOS2_MSK	LOS1_MSK	LOSX_MSK
24			ALIGN_MSK	FOS4_MSK	FOS3_MSK	FOS2_MSK	FOS1_MSK	LOL_MSK
25	N1_HS [2:0]				NC1_LS [19:16]			
26	NC1_LS [15:8]							
27	NC1_LS [7:0]							
28					NC2_LS [19:16]			
29	NC2_LS [15:8]							
30	NC2_LS [7:0]							
31					NC3_LS [19:16]			
32	NC3_LS [15:8]							
33	NC3_LS [7:0]							
34					NC4_LS [19:16]			
35	NC4_LS [15:8]							
36	NC4_LS [7:0]							
37					NC5_LS [19:16]			
38	NC5_LS [15:8]							
39	NC5_LS [7:0]							
40	N2_HS [2:0]				N2_LS [19:16]			
41	N2_LS [15:8]							
42	N2_LS [7:0]							
43						N31_ [18:16]		
44	N31_ [15:8]							
45	N31_ [7:0]							
46						N32_ [18:16]		
47	N31_ [15:8]							
48	N32_ [7:0]							
49						N33_ [18:16]		
50	N33_ [15:8]							
51	N33_ [7:0]							
52						N34_ [18:16]		
53	N34_ [15:8]							

Si5368

Register	D7	D6	D5	D4	D3	D2	D1	D0
54	N34_[7:0]							
55			CLKIN2RATE_[2:0]			CLKIN1RATE[2:0]		
56			CLKIN4RATE_[2:0]			CLKIN3RATE[2:0]		
128					CK4_ACTV_ REG	CK3_ACTV_ REG	CK2_ACTV_ REG	CK1_ACTV_ REG
129				LOS4_INT	LOS3_INT	LOS2_INT	LOS1_INT	LOSX_INT
130	CLAT- PROGRESS	DIGHOLD- VALID	ALIGN_INT	FOS4_INT	FOS3_INT	FOS2_INT	FOS1_INT	LOL_INT
131				LOS4_FLG	LOS3_FLG	LOS2_FLG	LOS1_FLG	LOSX_FLG
132		ALIGN_FLG	FOS4_FLG	FOS3_FLG	FOS2_FLG	FOS1_FLG	LOL_FLG	AIGN_ERR [8:8]
133	ALIGN_ERR [7:0]							
134	PARTNUM_RO [11:4]							
135	PARTNUM_RO [3:0]				REVID_RO [3:0]			
136	RST_REG	ICAL						
138					LOS4_EN [1:1]	LOS3_EN [1:1]	LOS2_EN [1:1]	LOS1_EN [1:1]
139	LOS4_EN [0:0]	LOS3_EN [0:0]	LOS2_EN [0:0]	LOS1_EN [0:0]	FOS4_EN	FOS3_EN	FOS2_EN	FOS1_EN
140	INDEPENDENTSKEW1 [7:0]							
141	INDEPENDENTSKEW2 [7:0]							
142	INDEPENDENTSKEW3 [7:0]							
143	INDEPENDENTSKEW4 [7:0]							
144	INDEPENDENTSKEW5 [7:0]							

6. Register Descriptions

Register 0.

Bit	D7	D6	D5	D4	D3	D2	D1	D0
Name		FREE_RUN	CKOUT_ALWAYS_ON		CK_CONFIG_REG		BYPASS_REG	
Type	R	R/W	R/W	R	R/W	R	R/W	R

Reset value = 0001 0100

Bit	Name	Function
7	Reserved	
6	FREE_RUN	<p>Free Run. Internal to the device, route XA/XB to CKIN2. This allows the device to lock to its external reference. 0: Disable Free Run 1: Enable</p>
5	CKOUT_ALWAYS_ON	<p>CKOUT Always On. This will bypass the SQ_ICAL function. Output will be available even if SQ_ICAL is on and ICAL is not complete or successful. See Table 9. 0: Squelch output until part is calibrated (ICAL). 1: Provide an output. Note: The frequency may be significantly off until the part is calibrated.</p>
4	Reserved	
3	CK_CONFIG_REG	<p>CK_CONFIG_REG. This bit controls the input clock configuration for either normal CLKIN function or FSYNC operation. Whenever CK_CONFIG_REG = 1, FSYNC_ALIGN_MODE must not be set to 1. 0: CKIN_1, 2, 3, 4 inputs do not have a synchronized relationship. CLKOUT5 is an independent output. There is no FSYNCOUT. 1: CKIN_1, 3 and CKIN_2, 4 Clock/FSYNC pairs. CKOUT5 is configured as the FSYNC output.</p>
2	Reserved	
1	BYPASS_REG	<p>Bypass Register. This bit enables or disables the PLL bypass mode. Use is only valid when the part is in digital hold or before the first ICAL. 0: Normal operation 1: Bypass mode. Selected input clock is connected to CKOUT buffers, bypassing PLL. Bypass mode does not support CMOS clock outputs.</p>
0	Reserved	

Register 1.

Bit	D7	D6	D5	D4	D3	D2	D1	D0
Name	CK_PRIOR4 [1:0]		CK_PRIOR3 [1:0]		CK_PRIOR2 [1:0]		CK_PRIOR1 [1:0]	
Type	R/W	R/W	R/W	R/W	R/W	R/W	R/W	R/W

Reset value = 1110 0100

Bit	Name	Function
7:6	CK_PRIOR4 [1:0]	Selects which of the input clocks will be 4th priority in the autoselection state machine. 00: CKIN1 is 4th priority 01: CKIN2 is 4th priority 10: CKIN3 is 4th priority 11: CKIN4 is 4th priority
5:4	CK_PRIOR3 [1:0]	Selects which of the input clocks will be 3rd priority in the autoselection state machine. 00: CKIN1 is 3rd priority 01: CKIN2 is 3rd priority 10: CKIN3 is 3rd priority 11: CKIN4 is 3rd priority
3:2	CK_PRIOR2 [1:0]	CK_PRIOR 2. Selects which of the input clocks will be 2nd priority in the autoselection state machine. 00: CKIN1 is 2nd priority 01: CKIN2 is 2nd priority 10: CKIN3 is 2nd priority 11: CKIN4 is 2nd priority
1:0	CK_PRIOR1 [1:0]	CK_PRIOR 1. Selects which of the input clocks will be 1st priority in the autoselection state machine. 00: CKIN1 is 1st priority 01: CKIN2 is 1st priority 10: CKIN3 is 1st priority 11: CKIN4 is 1st priority

Register 2.

Bit	D7	D6	D5	D4	D3	D2	D1	D0
Name	BWSEL_REG [3:0]							
Type	R/W				R	R	R	R

Reset value = 0100 0010

Bit	Name	Function
7:4	BWSEL_REG [3:0]	BWSEL_REG. Selects nominal f3dB bandwidth for PLL. See the DSPLLsim for settings. After BWSEL_REG is written with a new value, an ICAL is required for the change to take effect.
3:0	Reserved	

Register 3.

Bit	D7	D6	D5	D4	D3	D2	D1	D0
Name	CKSEL_REG [1:0]		DHOLD	SQ_ICAL				
Type	R/W		R/W	R/W	R	R	R	R

Reset value = 0000 0101

Bit	Name	Function
7:6	CKSEL_REG [1:0]	<p>CKSEL_REG.</p> <p>If the device is operating in manual register-based clock selection mode (AUTOSEL_REG = 00), and CKSEL_PIN = 0, then these bits select which input clock will be the active input clock. If CKSEL_PIN = 1, the CKSEL[1:0] input pins continue to control clock selection and CKSEL_REG is of no consequence.</p> <p>00: CKIN_1 selected. 01: CKIN_2 selected. 10: CKIN_3 selected. 11: CKIN_4 selected.</p>
5	DHOLD	<p>DHOLD.</p> <p>Forces the part into digital hold. This bit overrides all other manual and automatic clock selection controls.</p> <p>0: Normal operation. 1: Force digital hold mode. Overrides all other settings and ignores the quality of all of the input clocks.</p>
4	SQ_ICAL	<p>SQ_ICAL.</p> <p>This bit determines if the output clocks will remain enabled or be squelched (disabled) during an internal calibration. See Table 9.</p> <p>0: Output clocks enabled during ICAL. 1: Output clocks disabled during ICAL.</p>
3:0	Reserved	

Register 4.

Bit	D7	D6	D5	D4	D3	D2	D1	D0
Name	AUTOSEL_REG [1:0]			HIST_DEL [4:0]				
Type	R/W		R	R/W				

Reset value = 0001 0010

Bit	Name	Function
7:6	AUTOSEL_REG [1:0]	AUTOSEL_REG [1:0]. Selects method of input clock selection to be used. 00: Manual (either register or pin controlled. See CKSEL_PIN). 01: Automatic Non-Revertive 10: Automatic Revertive 11: Reserved
5	Reserved	
4:0	HIST_DEL [4:0]	HIST_DEL [4:0]. Selects amount of delay to be used in generating the history information MHIST, the value of M used during Digital Hold.

Register 5.

Bit	D7	D6	D5	D4	D3	D2	D1	D0
Name	ICMOS [1:0]		SFOUT2_REG [2:0]			SFOUT1_REG [2:0]		
Type	R/W		R/W			R/W		

Reset value = 1110 1101

Bit	Name	Function
7:6	ICMOS [1:0]	<p>ICMOS [1:0]. When the output buffer is set to CMOS mode, these bits determine the output buffer drive strength. The first number below refers to 3.3 V operation; the second to 1.8 V operation. These values assume CKOUT+ is tied to CKOUT–.</p> <p>00: 8 mA/2 mA 01: 16 mA/4 mA 10: 24 mA/6 mA 11: 32 mA (3.3 V operation)/8 mA (1.8 V operation)</p>
5:3	SFOUT2_REG [2:0]	<p>SFOUT2_REG [2:0]. Controls output signal format and disable for CKOUT2 output buffer. The LVPECL and CMOS output formats draw more current than either LVDS or CML; however, there are restrictions in the allowed output format pin settings so that the maximum power dissipation for the TQFP devices is limited when they are operated at 3.3 V. When there are four enabled LVPECL or CMOS outputs, the fifth output must be disabled. When there are five enabled outputs, there can be no more than three outputs that are either LVPECL or CMOS.</p> <p>000: Reserved 001: Disable 010: CMOS (Bypass mode not supported.) 011: Low swing LVDS 100: Reserved 101: LVPECL 110: CML 111: LVDS</p>
2:0	SFOUT1_REG [2:0]	<p>SFOUT1_REG [2:0]. Controls output signal format and disable for CKOUT1 output buffer. The LVPECL and CMOS output formats draw more current than either LVDS or CML; however, there are restrictions in the allowed output format pin settings so that the maximum power dissipation for the TQFP devices is limited when they are operated at 3.3 V. When there are four enabled LVPECL or CMOS outputs, the fifth output must be disabled. When there are five enabled outputs, there can be no more than three outputs that are either LVPECL or CMOS.</p> <p>000: Reserved 001: Disable 010: CMOS (Bypass mode not supported.) 011: Low swing LVDS 100: Reserved 101: LVPECL 110: CML 111: LVDS</p>

Register 6.

Bit	D7	D6	D5	D4	D3	D2	D1	D0
Name			SFOUT4_REG [2:0]			SFOUT3_REG [2:0]		
Type	R	R	R/W			R/W		

Reset value = 0010 1100

Bit	Name	Function
7:6	Reserved	
5:3	SFOUT4_REG [2:0]	<p>SFOUT4_REG [2:0]. Controls output signal format and disable for CKOUT4 output buffer. The LVPECL and CMOS output formats draw more current than either LVDS or CML; however, there are restrictions in the allowed output format pin settings so that the maximum power dissipation for the TQFP devices is limited when they are operated at 3.3 V. When there are four enabled LVPECL or CMOS outputs, the fifth output must be disabled. When there are five enabled outputs, there can be no more than three outputs that are either LVPECL or CMOS.</p> <p>000: Reserved 001: Disable 010: CMOS (Bypass mode not supported.) 011: Low swing LVDS 100: Reserved 101: LVPECL 110: CML 111: LVDS</p>
2:0	SFOUT3_REG [2:0]	<p>SFOUT3_REG [2:0]. Controls output signal format and disable for CKOUT3 output buffer. The LVPECL and CMOS output formats draw more current than either LVDS or CML; however, there are restrictions in the allowed output format pin settings so that the maximum power dissipation for the TQFP devices is limited when they are operated at 3.3 V. When there are four enabled LVPECL or CMOS outputs, the fifth output must be disabled. When there are five enabled outputs, there can be no more than three outputs that are either LVPECL or CMOS.</p> <p>000: Reserved 001: Disable 010: CMOS (Bypass mode not supported.) 011: Low swing LVDS 100: Reserved 101: LVPECL 110: CML 111: LVDS</p>

Register 7.

Bit	D7	D6	D5	D4	D3	D2	D1	D0
Name			SFOUT5_REG [2:0]			FOSREFSEL [2:0]		
Type	R	R	R/W			R/W		

Reset value = 0010 1010

Bit	Name	Function
7:6	Reserved.	Reserved.
5:3	SFOUT5_REG [2:0]	<p>SFOUT5_REG [2:0] Controls output signal format and disable for CKOUT5 output buffer. The LVPECL and CMOS output formats draw more current than either LVDS or CML; however, there are restrictions in the allowed output format pin settings so that the maximum power dissipation for the TQFP devices is limited when they are operated at 3.3 V. When there are four enabled LVPECL or CMOS outputs, the fifth output must be disabled. When there are five enabled outputs, there can be no more than three outputs that are either LVPECL or CMOS.</p> <p>000: Reserved 001: Disable 010: CMOS 011: Low swing LVDS 100: Reserved 101: LVPECL 110: CML 111: LVDS</p>
2:0	FOSREFSEL [2:0]	<p>FOSREFSEL [2:0]. Selects which input clock is used as the reference frequency for Frequency Off-Set (FOS) alarms.</p> <p>000: XA/XB (External reference) 001: CKIN1 010: CKIN2 011: CKIN3 100: CKIN4 101: Reserved 110: Reserved 111: Reserved</p>

Register 8.

Bit	D7	D6	D5	D4	D3	D2	D1	D0
Name	HLOG_4[1:0]		HLOG_3[1:0]		HLOG_2[1:0]		HLOG_1[1:0]	
Type	R/W		R/W		R/W		R/W	

Reset value = 0000 0000

Bit	Name	Function
7:6	HLOG_4 [1:0]	HLOG_4 [1:0]. 00: Normal operation 01: Holds CKOUT4 output at static logic 0. Entrance and exit from this state will occur without glitches or runt pulses. 10: Holds CKOUT4 output at static logic 1. Entrance and exit from this state will occur without glitches or runt pulses. 11: Reserved
5:4	HLOG_3 [1:0]	HLOG_3 [1:0]. 00: Normal operation 01: Holds CKOUT3 output at static logic 0. Entrance and exit from this state will occur without glitches or runt pulses. 10: Holds CKOUT3 output at static logic 1. Entrance and exit from this state will occur without glitches or runt pulses. 11: Reserved.
3:2	HLOG_2 [1:0]	HLOG_2 [1:0]. 00: Normal operation 01: Holds CKOUT2 output at static logic 0. Entrance and exit from this state will occur without glitches or runt pulses. 10: Holds CKOUT2 output at static logic 1. Entrance and exit from this state will occur without glitches or runt pulses. 11: Reserved.
1:0	HLOG_1 [1:0]	HLOG_1 [1:0]. 00: Normal operation 01: Holds CKOUT1 output at static logic 0. Entrance and exit from this state will occur without glitches or runt pulses. 10: Holds CKOUT1 output at static logic 1. Entrance and exit from this state will occur without glitches or runt pulses. 11: Reserved

Register 9.

Bit	D7	D6	D5	D4	D3	D2	D1	D0
Name	HIST_AVG [4:0]						HLOG_5 [1:0]	
Type	R/W					R	R/W	

Reset value = 1100 0000

Bit	Name	Function
7:3	HIST_AVG [4:0]	HIST_AVG [4:0]. Selects amount of averaging time to be used in generating MHIST, the value of M used during digital hold. See Family Reference Manual for settings.
2	Reserved	
1:0	HLOG_5 [1:0]	HLOG_5 [1:0]. 00: Normal Operation 01: Holds CKOUT5 output at static logic 0. Entrance and exit from this state will occur without glitches or runt pulses. 10: Holds CKOUT5 output at static logic 1. Entrance and exit from this state will occur without glitches or runt pulses. 11: Reserved

Register 10.

Bit	D7	D6	D5	D4	D3	D2	D1	D0
Name			DSBL5_ REG		DSBL4_ REG	DSBL3_ REG	DSBL2_ REG	DSBL1_ REG
Type	R	R	R/W	R	R/W	R/W	R	R

Reset value = 0000 0000

Bit	Name	Function
7:6	Reserved	
5	DSBL5_REG	DSBL5_REG. This bit controls the powerdown and disable of the CKOUT5 output buffer. If disable mode is selected, the NC5_LS output divider is also powered down. 0: CKOUT5 enabled. 1: CKOUT5 disabled.
4	Reserved	
3	DSBL4_REG	DSBL4_REG. This bit controls the powerdown and disable of the CKOUT4 output buffer. If disable mode is selected, the NC4 output divider is also powered down. 0'b=CKOUT4 enabled 1'b=CKOUT4 disabled
2	DSBL3_REG	DSBL3_REG. This bit controls the powerdown and disable of the CKOUT3 output buffer. If disable mode is selected, the NC3 output divider is also powered down. 0: CKOUT3 enabled 1: CKOUT3 disabled
1	DSBL2_REG	DSBL2_REG. This bit controls the powerdown and disable of the CKOUT2 output buffer. If disable mode is selected, the NC2 output divider is also powered down. 0: CKOUT2 enabled 1: CKOUT2 disabled
0	DSBL1_REG	DSBL1_REG. This bit controls the powerdown and disable of the CKOUT1 output buffer. If disable mode is selected, the NC1 output divider is also powered down. 0: CKOUT1 enabled 1: CKOUT1 disabled

Register 11.

Bit	D7	D6	D5	D4	D3	D2	D1	D0
Name	ALIGN_THR [2:0]				PD_CK4	PD_CK3	PD_CK2	PD_CK1
Type	R/W	R/W	R/W	R	R/W	R/W	R/W	R/W

Reset value = 0100 0000

Bit	Name	Function
7:5	ALIGN_THR [2:0]	<p>ALIGN_THR [2:0]. These bits control the threshold for the alignment error alarm. Input to output sync phase skews that deviate more than the alignment threshold from the ideal value (set by FSYNC_SKEW[16:0]) in either the leading or lagging direction trigger the alignment alarm. Value is in units of Tclkout2.</p> <p>000: 4 001: 8 010: 16 011: 32 100: 48 101: 64 110: 96 111: 128</p>
4	Reserved	
3	PD_CK4	<p>PD_CK4. This bit controls the powerdown of the CKIN4 input buffer. 0: CKIN4 enabled 1: CKIN4 disabled</p>
2	PD_CK3	<p>PD_CK3. This bit controls the powerdown of the CKIN3 input buffer. 0: CKIN3 enabled 1: CKIN3 disabled</p>
1	PD_CK2	<p>PD_CK2. This bit controls the powerdown of the CKIN2 input buffer. 0: CKIN2 enabled 1: CKIN2 disabled</p>
0	PD_CK1	<p>PD_CK1. This bit controls the powerdown of the CKIN1 input buffer. 0: CKIN1 enabled 1: CKIN1 disabled</p>

Register 12.

Bit	D7	D6	D5	D4	D3	D2	D1	D0
Name	FPW_VALID	FSYNC_ALIGN_REG	FSYNC_ALIGN_MODE	FSYNC_SWTCH_REG	FSKEW_VALID	FSYNC_SKEW [16:16]	FSYNC_PW [9:8]	
Type	R/W	R/W	R/W	R/W	R/W	R/W	R/W	

Reset value = 1000 1000

Bit	Name	Function
7	FPW_VALID	<p>FPW_VALID.</p> <p>When in frame sync mode (CK_CONFIG_REG=1), before writing either a new FSYNC_PW[9:0] or NC5_LS [19:0] value, this bit must be set to zero. This causes the existing FSYNC_PW [9:0] or NC5_LS[19:0] value to be held by the internal state machine for use while the new values are written. Once the new FSYNC_PW [9:0] or NC5_LS [19:0] values are completely written, set FPW_VALID = 1 to enable their use.</p> <p>0: Memorize existing FSYNC_PW[9:0] and NC5_LS [19:0] values and ignore intermediate register values during write of new FSYNC_PW [9:0] and NC5_LS [19:0] values.</p> <p>1: Use FSYNC_PW[9:0] value directly from registers</p>
6	FSYNC_ALIGN_REG	<p>FSYNC_ALIGN_REG.</p> <p>If FSYNC_ALIGN_PIN=0, this bit controls realignment of FSYNCOUT to the active sync input (CKIN_3 or CKIN_4). If FSYNC_ALIGN_PIN=1, the FSYNC_ALIGN pin controls this function.</p> <p>0: No realignment</p> <p>1: Active</p>
5	FSYNC_ALIGN_MODE	<p>FSYNC_ALIGN_MODE.</p> <p>This bit must be set to 1 when in frame sync mode (when CK_CONFIG_REG = 1).</p>
4	FSYNC_SWTCH_REG	<p>FSYNC_SWTCH_REG.</p> <p>Enables or disables the use of the CKIN3 and CKIN4 loss-of-signal indicators as inputs to the automatic clock selection state machine for the clock configuration mode supporting frame sync switching (CK_CONFIG=1 or CK_CONFIG_REG=1).</p> <p>0: CKIN3 and CKIN4 status not used in clock selection</p> <p>1: CKIN3 and CKIN4 status used in clock selection</p>
3	FSKEW_VALID	<p>FSKEW_VALID.</p> <p>Before writing a new FSYNC_SKEW[16:0] value, this bit must be set to zero, which causes the existing FSYNC_SKEW[16:0] value to be held internally by the skew alignment state machine for use while the new value is being written. Once the new FSYNC_SKEW[16:0] is completely written, set FSKEW_VALID=1 to enable its use.</p> <p>0: Memorize existing FSYNC_SKEW[16:0] value and ignore intermediate register values during write of new FSYNC_SKEW value.</p> <p>1: Use FSYNC_SKEW[[16:0] value directly from registers.</p>

Bit	Name	Function
2	FSYNC_SKEW [16:0]	FSYNC_SKEW [16:0]. Phase skew control for FSYNCOUT. The resolution of the skew control is 1/fCKOUT2. Entered values should be less than the FSYNCOUT period. 0 0000 0000 0000 0000=Zero phase skew. 0 0000 0000 0000 0001=Delay of 1 period of CLKOUT_2. 1 0010 1111 1011 1111=Delay of 77,759 periods of CKOUT2. If CKOUT2=622.08 MHz and FSYNCOUT=8 kHz, this delay equals 125 ms - 1/fCKOUT2 and is the maximum value that should be entered. 1 1111 1111 1111 1111=Delay of 131,071 periods of CKOUT2.
1:0	FSYNC_PW [9:0]	FSYNC_PW [9:0]. These bits control the pulse width of the FSYNCOUT signal. The resolution of the pulse width control is 1/fCKOUT2. 0000000000=50% duty cycle. 0000000001=1 period of CKOUT2. 0000000010=2 periods of CKOUT2. 1111111111=1023 periods of CKOUT2.

Register 13.

Bit	D7	D6	D5	D4	D3	D2	D1	D0
Name	FSYNC_PW [7:0]							
Type	R/W							

Reset value = 0000 0001

Bit	Name	Function
7:0	FSYNC_PW [7:0]	FSYNC_PW [7:0]. See Register 12.

Register 14.

Bit	D7	D6	D5	D4	D3	D2	D1	D0
Name	FSYNC_SKEW [15:8]							
Type	R/W							

Reset value = 0000 0000

Bit	Name	Function
7:0	FSYNC_SKEW [15:8]	FSYNC_SKEW [15:8]. See Register 12.

Register 15.

Bit	D7	D6	D5	D4	D3	D2	D1	D0
Name	FSYNC_SKEW [7:0]							
Type	R/W							

Reset value = 0000 0000

Bit	Name	Function
7:0	FSYNC_SKEW [7:0]	FSYNC_SKEW [7:0]. See Register 12.

Register 16.

Bit	D7	D6	D5	D4	D3	D2	D1	D0
Name	CLAT [7:0]							
Type	R/W							

Reset value = 0000 0000

Bit	Name	Function
7:0	CLAT [7:0]	CLAT [7:0]. With INCDEC_PIN=0, this register sets the phase delay for CKOUT_n in units of N1_HS/Fosc. Note: This can take as long as 20 seconds. 01111111: +127 x 1/fOSC (2s compliment) 00000000: 0 10000000: -128 x 1/fOSC (2s compliment) If N2-HS[2:0] = 000, CLAT does not work.

Register 17.

Bit	D7	D6	D5	D4	D3	D2	D1	D0
Name	FLAT_VALID							
Type	R/W							

Reset value = 1000 0000

Bit	Name	Function
7	FLAT_VAILD	<p>FLAT_VAILD.</p> <p>Before writing a new FLAT[14:0] value, this bit must be set to zero, which causes the existing FLAT[14:0] value to be held internally for use while the new value is being written. Once the new FLAT[14:0] value is completely written, set FLAT_VALID = 1 to enable its use.</p> <p>0: Memorize existing FLAT[14:0] value and ignore intermediate register values during write of new FLAT[14:0] value.</p> <p>1: Use FLAT[14:0] value directly from registers.</p>
6:0	FLAT [14:0]	<p>FLAT [14:0].</p> <p>Fine resolution control for overall device latency from input clocks to output clocks. Positive values increase the skew. See DSPLLsim for details.</p>

Register 18.

Bit	D7	D6	D5	D4	D3	D2	D1	D0
Name	FLAT [7:0]							
Type	R/W							

Reset value = 0000 0000

Bit	Name	Function
7:0	FLAT [7:0]	<p>FLAT [7:0].</p> <p>See Register 17.</p>

Register 19.

Bit	D7	D6	D5	D4	D3	D2	D1	D0
Name	FOS_EN	FOS_THR [1:0]		VALTIME [1:0]		LOCKT [2:0]		
Type	R/W	R/W		R/W		R/W		

Reset value = 0010 1100

Bit	Name	Function
7	FOS_EN	FOS_EN. Frequency offset enable globally disables FOS. See the individual FOS enables (FOSx_EN, register 139). 00: FOS disable 01: FOS enabled by FOSx_EN
6:5	FOS_THR [1:0]	FOS_THR [1:0]. Frequency Offset at which FOS is declared: 00: ± 11 to 12 ppm Stratum 3/3E compliant, with a Stratum 3/3E used for REFCLK. 01: ± 48 to 49 ppm (SMC). 10: ± 30 ppm SONET Minimum Clock (SMC), with a Stratum 3/3E used for REFCLK. 11: ± 200 ppm
4:3	VALTIME [1:0]	VALTIME [1:0]. Sets amount of time for input clock to be valid before the associated alarm is removed. 00: 2 ms 01: 100 ms 10: 200 ms 11: 13 seconds
2:0	LOCKT [2:0]	LOCKT [2:0]. Sets retrigger interval for one shot monitoring phase detector output. One shot is triggered by phase slip in DSPLL. Refer to the Family Reference Manual for more details. 000: 106 ms 001: 53 ms 010: 26.5 ms 011: 13.3 ms 100: 6.6 ms 101: 3.3 ms 110: 1.66 ms 111: 833 us

Register 20.

Bit	D7	D6	D5	D4	D3	D2	D1	D0
Name			ALRMOUT_PIN	CK3_BAD_PIN	CK2_BAD_PIN	CK1_BAD_PIN	LOL_PIN	INT_PIN
Type	R	R	R/W	R/W	R/W	R/W	R/W	R/W

Reset value = 0011 1100

Bit	Name	Function
7:6	Reserved	
5	ALRMOUT_PIN	<p>ALRMOUT_PIN. The ALRMOUT status can be reflected on the ALRMOUT output pin. The request to reflect the interrupt status on this pin (INT_PIN=1) overrides the ALRMOUT_PIN request. 0: ALRMOUT not reflected on output pin. Output pin disabled if INT_PIN=0. 1: ALRMOUT reflected to output pin if INT_PIN=0. If INT_PIN=1, interrupt status appears on the output pin and ALRMOUT is not available on an output pin.</p>
4	CK3_BAD_PIN	<p>CK3_BAD_PIN. The CK3_BAD status can be reflected on the C3B output pin. 0: C3B output pin tristated 1: C3B status reflected to output pin</p>
3	CK2_BAD_PIN	<p>CK2_BAD_PIN. The CK2_BAD status can be reflected on the C2B output pin. 0: C2B output pin tristated 1: C2B status reflected to output pin</p>
2	CK1_BAD_PIN	<p>CK1_BAD_PIN. The CK1_BAD status can be reflected on the C1B output pin. 0: C1B output pin tristated 1: C1B status reflected to output pin</p>
1	LOL_PIN	<p>LOL_PIN. The LOL_INT status bit can be reflected on the LOL output pin. 0: LOL output pin tristated 1: LOL_INT status reflected to output pin</p>
0	INT_PIN	<p>INT_PIN. Reflects the interrupt status on the INT output pin. 0: Interrupt status not displayed on INT output pin. If ALRMOUT_PIN = 0, output pin is tristated. 1: Interrupt status reflected to output pin. ALRMOUT_PIN ignored.</p>

Register 21.

Bit	D7	D6	D5	D4	D3	D2	D1	D0
Name	INCDEC_PIN		FSYNC_ALIGN_PIN	CK4_ACTV_PIN	CK3_ACTV_PIN	CK2_ACTV_PIN	CK1_ACTV_PIN	CKSEL_PIN
Type	R/W	Force 1	R/W	R/W	R/W	R/W	R/W	R/W

Reset value = 1111 1111

Bit	Name	Function
7	INCDEC_PIN	INCDEC_PIN. Determines how coarse skew adjustments can be made. The adjustments can be made via hardware using the INC/DEC pins or with software via the CLAT register. 0: INC and DEC inputs ignored; use CLAT register to adjust skew. 1: INC and DEC inputs control output phase increment/decrement.
6	Reserved	
5	FSYNC_ALIGN_PIN	FSYNC_ALIGN_PIN. Realignment of FSYNCOOUT can be controlled by the FSYNC_ALIGN input pin instead of the FSYNC_ALIGN_REG register bit. 0: FSYNC_ALIGN pin ignored. FSYNC_ALIGN_REG register bit controls FSYNCOOUT realignment. 1: FSYNC_ALIGN pin controls FSYNCOOUT realignment.
4	CK4_ACTV_PIN	CK4_ACTV_PIN. If the CKSEL[1]/CK4_ACTV pin is functioning as the CK4_ACTV output (see CKSEL[1]/CK4_ACTV pin description on CK4_ACTV), the CK4_ACTV_REG status bit can be reflected to the CK4_ACTV output pin using the CK4_ACTV_PIN enable function. 0: CK4_ACTV output pin tristated 1: CK4_ACTV status reflected to output pin.
3	CK3_ACTV_PIN	CK3_ACTV_PIN. If the CKSEL[0]/CK3_ACTV pin is functioning as the CK3_ACTV output (see CKSEL[0]/CK3_ACTV pin description on CK3_ACTV), the CK3_ACTV_REG status bit can be reflected to the CK3_ACTV output pin using the CK3_ACTV_PIN enable function. 0: CK3_ACTV output pin tristated. 1: CK3_ACTV status reflected to output pin.
2	CK2_ACTV_PIN	CK2_ACTV_PIN. The CK2_ACTV_REG status bit can be reflected to the CK2_ACTV output pin using the CK2_ACTV_PIN enable function. 0: CK2_ACTV output pin tristated. 1: CK2_ACTV status reflected to output pin.

Si5368

Bit	Name	Function
1	CK1_ACTV_PIN	CK1_ACTV_PIN. The CK1_ACTV_REG status bit can be reflected to the CK1_ACTV output pin using the CK1_ACTV_PIN enable function. 0: CK1_ACTV output pin tristated. 1: CK1_ACTV status reflected to output pin.
0	CKSEL_PIN	CKSEL_PIN. If manual clock selection is being used, clock selection can be controlled via the CKSEL_REG[1:0] register bits or the CKSEL[1:0] input pins. 0: CKSEL pins ignored. CKSEL_REG[1:0] register bits control clock selection. 1: CKSEL[1:0] input pins controls clock selection.

Note: The CKx_ACTV_PIN bits in this register are of consequence only when CKSEL_PIN is 0.

Register 22.

Bit	D7	D6	D5	D4	D3	D2	D1	D0
Name	FSYNC_ALIGN_POL	FSYNC_POL		FSYNCOUT_POL	CK_ACTV_POL	CK_BAD_POL	LOL_POL	INT_POL
Type	R/W	R/W	R	R/W	R/W	R/W	R/W	R/W

Reset value = 1101 1111

Bit	Name	Function
7	FSYNC_ALIGN_POL	FSYNC_ALIGN_POL. Sets the active polarity or edge for the FSYNC_ALIGN input pin. 0: Active low (falling edge). 1: Active high (rising edge).
6	FSYNC_POL	FSYNC_POL. Sets the active polarity and edge for the CKIN_3 and CKIN_4 inputs when used as frame sync inputs. 0: Active low (falling edge). 1: Active high (rising edge).
5	Reserved	
4	FSYNCOUT_POL	FSYNCOUT_POL. Controls active polarity of FSYNCOUT. 0: Active low 1: Active high

Bit	Name	Function
3	CK_ACTV_POL	CK_ACTV_POL. Sets the active polarity for the CK1_ACTV, CK2_ACTV, CK3_ACTV, and CK4_ACTV signals when reflected on an output pin. 0: Active low 1: Active high
2	CK_BAD_POL	CK_BAD_POL. Sets the active polarity for the C1B, C2B, C3B, and ALRMOUT signals when reflected on output pins. 0: Active low 1: Active high
1	LOL_POL	LOL_POL. Sets the active polarity for the LOL status when reflected on an output pin. 0: Active low 1: Active high
0	INT_POL	INT_POL. Sets the active polarity for the interrupt status when reflected on the INT_ALM output pin. 0: Active low 1: Active high

Register 23.

Bit	D7	D6	D5	D4	D3	D2	D1	D0
Name				LOS4_MSKE	LOS3_MSKE	LOS2_MSKE	LOS1_MSKE	LOSX_MSKE
Type	R	R	R	R/W	R/W	R/W	R/W	R/W

Reset value = 0001 1111

Bit	Name	Function
7:5	Reserved	
4	LOS4_MSKE	LOS4_MSKE. Determines if a LOS on CKIN4 (LOS4_FLG) is used in the generation of an interrupt. Writes to this register do not change the value held in the LOS4_FLG register. 0: LOS4 alarm triggers active interrupt on INT output (if INT_PIN=1). 1: LOS4_FLG ignored in generating interrupt output.
3	LOS3_MSKE	LOS3_MSKE. Determines if a LOS on CKIN3 (LOS3_FLG) is used in the generation of an interrupt. Writes to this register do not change the value held in the LOS3_FLG register. 0: LOS3 alarm triggers active interrupt on INT output (if INT_PIN=1). 1: LOS3_FLG ignored in generating interrupt output.

2	LOS2_MSK	<p>LOS2_MSK. Determines if a LOS on CKIN2 (LOS2_FLG) is used in the generation of an interrupt. Writes to this register do not change the value held in the LOS2_FLG register. 0: LOS2 alarm triggers active interrupt on INT output (if INT_PIN=1). 1: LOS2_FLG ignored in generating interrupt output.</p>
1	LOS1_MSK	<p>LOS1_MSK. Determines if a LOS on CKIN1 (LOS1_FLG) is used in the generation of an interrupt. Writes to this register do not change the value held in the LOS1_FLG register. 0: LOS1 alarm triggers active interrupt on INT output (if INT_PIN=1). 1: LOS1_FLG ignored in generating interrupt output.</p>
0	LOSX_MSK	<p>LOSX_MSK. Determines if a LOS on XA/XB(LOSX_FLG) is used in the generation of an interrupt. Writes to this register do not change the value held in the LOSX_FLG register. 0: LOSX alarm triggers active interrupt on INT output (if INT_PIN=1). 1: LOSX_FLG ignored in generating interrupt output.</p>

Register 24.

Bit	D7	D6	D5	D4	D3	D2	D1	D0
Name			ALIGN_MSK	FOS4_MSK	FOS3_MSK	FOS2_MSK	FOS1_MSK	LOL_MSK
Type	R	R	R/W	R/W	R/W	R/W	R/W	R/W

Reset value = 0011 1111

Bit	Name	Function
7:6	Reserved	
5	ALIGN_MSK	<p>ALIGN_MSK. Determines if an alignment alarm (ALIGN_FLG) is used in the generation of an interrupt. Writes to this register do not change the value held in the ALIGN_FLG register. 0: FSYNC alignment alarm triggers active interrupt on INT output (if INT_PIN=1). 1: ALIGN_FLG ignored in generating interrupt output.</p>
4	FOS4_MSK	<p>FOS4_MSK. Determines if the FOS4_FLG is used to in the generation of an interrupt. Writes to this register do not change the value held in the FOS4_FLG register. 0: FOS4 alarm triggers active interrupt on INToutput (if INT_PIN=1). 1: FOS4_FLG ignored in generating interrupt output.</p>
3	FOS3_MSK	<p>FOS3_MSK. Determines if the FOS3_FLG is used in the generation of an interrupt. Writes to this register do not change the value held in the FOS3_FLG register. 0: FOS3 alarm triggers active interrupt on INT output (if INT_PIN=1). 1: FOS3_FLG ignored in generating interrupt output.</p>

2	FOS2_MSK	<p>FOS2_MSK.</p> <p>Determines if the FOS2_FLG is used in the generation of an interrupt. Writes to this register do not change the value held in the FOS2_FLG register.</p> <p>0: FOS2 alarm triggers active interrupt on INT output (if INT_PIN=1).</p> <p>1: FOS2_FLG ignored in generating interrupt output.</p>
1	FOS1_MSK	<p>FOS1_MSK.</p> <p>Determines if the FOS1_FLG is used in the generation of an interrupt. Writes to this register do not change the value held in the FOS1_FLG register.</p> <p>0: FOS1 alarm triggers active interrupt on INT output (if INT_PIN=1).</p> <p>1: FOS1_FLG ignored in generating interrupt output.</p>
0	LOL_MSK	<p>LOL_MSK.</p> <p>Determines if the LOL_FLG is used in the generation of an interrupt. Writes to this register do not change the value held in the LOL_FLG register.</p> <p>0: LOL alarm triggers active interrupt on INT output (if INT_PIN=1).</p> <p>1: LOL_FLG ignored in generating interrupt output.</p>

Register 25.

Bit	D7	D6	D5	D4	D3	D2	D1	D0
Name	N1_HS [2:0]				NC1_LS [19:16]			
Type	R/W			R	R/W			

Reset value = 0010 0000

Bit	Name	Function
7:5	N1_HS [2:0]	<p>N1_HS [2:0].</p> <p>Sets value for N1 high speed divider which drives NCn_LS (n = 1 to 4) low-speed divider.</p> <p>000: N1 = 4 Note: Changing the coarse skew via the INC pin is disabled for this value.</p> <p>001: N1 = 5</p> <p>010: N1 = 6</p> <p>011: N1 = 7</p> <p>100: N1 = 8</p> <p>101: N1 = 9</p> <p>110: N1 = 10</p> <p>111: N1 = 11</p>
4	Reserved	
3:0	NC1_LS [19:16]	<p>NC1_LS [19:0].</p> <p>Sets value for NC1 low-speed divider, which drives CKOUT1 output. Must be 0 or odd.</p> <p>00000000000000000000 = 1</p> <p>00000000000000000001 = 2</p> <p>00000000000000000011 = 4</p> <p>00000000000000000101 = 6</p> <p>...</p> <p>11111111111111111111 = 2^{20}</p> <p>Valid divider values = [1, 2, 4, 6, ..., 2^{20}].</p>

Register 26.

Bit	D7	D6	D5	D4	D3	D2	D1	D0
Name	NC1_LS [15:8]							
Type	R/W							

Reset value = 0000 0000

Bit	Name	Function
7:0	NC1_LS [15:8]	NC1_LS [15:8]. See Register 25.

Register 27.

Bit	D7	D6	D5	D4	D3	D2	D1	D0
Name	NC1_LS [7:0]							
Type	R/W							

Reset value = 0011 0001

Bit	Name	Function
7:0	NC1_LS [7:0]	NC1_LS [7:0]. See Register 25.

Register 28.

Bit	D7	D6	D5	D4	D3	D2	D1	D0
Name					NC2_LS [19:16]			
Type	R	R	R	R	R/W			

Reset value = 0000 0000

Bit	Name	Function
7:4	Reserved	
3:0	NC1_LS [19:0]	<p>NC2_LS [19:16]. Sets value for NC2 low-speed divider, which drives CKOUT2 output. Must be 0 or odd.</p> <p>00000000000000000000=1 00000000000000000001=2 00000000000000000011=4 00000000000000000101=6 ... 11111111111111111111 = 2^{20} Valid divider values = [1, 2, 4, 6, ..., 2^{20}]</p>

Register 29.

Bit	D7	D6	D5	D4	D3	D2	D1	D0
Name	NC2_LS [15:8]							
Type	R/W							

Reset value = 0000 0000

Bit	Name	Function
7:0	NC2_LS [15:8]	NC2_LS [15:8]. See Register 28.

Register 30.

Bit	D7	D6	D5	D4	D3	D2	D1	D0
Name	NC2_LS [7:0]							
Type	R/W							

Reset value = 0011 0001

Bit	Name	Function
7:0	NC2_LS [7:0]	NC2_LS [7:0]. See Register 28.

Register 31.

Bit	D7	D6	D5	D4	D3	D2	D1	D0
Name					NC3_LS [19:16]			
Type	R	R	R	R	R/W			

Reset value = 0000 0000

Bit	Name	Function
7:4	Reserved	
3:0	NC3_LS [19:0]	<p>NC3_LS [19:0]. Sets value for NC3 low-speed divider, which drives CKOUT3 output. Must be 0 or odd. 00000000000000000000=1 00000000000000000001=2 00000000000000000011=4 00000000000000000101=6 ... 11111111111111111111=2²⁰ Valid divider values=[1, 2, 4, 6, ..., 2²⁰].</p>

Register 32.

Bit	D7	D6	D5	D4	D3	D2	D1	D0
Name	NC3_LS [15:8]							
Type	R/W							

Reset value = 0000 0000

Bit	Name	Function
7:0	NC3_LS [15:8]	<p>NC3_LS [15:8]. See Register 31.</p>

Register 33.

Bit	D7	D6	D5	D4	D3	D2	D1	D0
Name	NC3_LS [7:0]							
Type	R/W							

Reset value = 0011 0001

Bit	Name	Function
7:0	NC3_LS [7:0]	NC3_LS [7:0]. See Register 31.

Register 34.

Bit	D7	D6	D5	D4	D3	D2	D1	D0
Name	NC4_LS [19:16]							
Type	R	R	R	R	R/W			

Reset value = 0000 0000

Bit	Name	Function
7:4	Reserved	
3:0	NC4_LS [19:0]	NC4_LS [19:0]. Sets value for NC4 low-speed divider, which drives CKOUT4 output. Must be 0 or odd. 00000000000000000000 = 1 00000000000000000001 = 2 00000000000000000011 = 4 00000000000000000101 = 6 ... 11111111111111111111 = 2^{20} Valid divider values = [1, 2, 4, 6, ..., 2^{20}].

Register 35.

Bit	D7	D6	D5	D4	D3	D2	D1	D0
Name	NC4_LS [15:8]							
Type	R/W							

Reset value = 0000 0000

Bit	Name	Function
7:0	NC4_LS [15:8]	NC4_LS [15:8]. See Register 34.

Register 36.

Bit	D7	D6	D5	D4	D3	D2	D1	D0
Name	NC4_LS [7:0]							
Type	R/W							

Reset value = 0011 0001

Bit	Name	Function
7:0	NC4_LS [7:0]	NC4_LS [7:0]. See Register 34.

Register 37.

Bit	D7	D6	D5	D4	D3	D2	D1	D0
Name	NC5_LS [19:16]							
Type	R	R	R	R	R/W			

Reset value = 0000 0000

Bit	Name	Function
7:4	Reserved	
3:0	NC5_LS [19:0]	<p>NC5_LS [19:0]. Sets value for NC5 low-speed divider, which drives CKOUT5 output. Must be 0 or odd. When CK_CONFIG = 0: 00000000000000000000 = 1 00000000000000000001 = 2 00000000000000000011 = 4 00000000000000000101 = 6 ... 11111111111111111111 = 2²⁰</p> <p>Valid divider values=[1, 2, 4, 6, ..., 2²⁰]. When CK_CONFIG=1, maximum value limited to 2¹⁹.: 00000000000000000000 = 1 00000000000000000001 = 2 00000000000000000011 = 4 00000000000000000101 = 6 ... 01111111111111111111 = 2¹⁹ Valid divider values = [1, 2, 4, 6, ..., 2¹⁹].</p>

Register 38.

Bit	D7	D6	D5	D4	D3	D2	D1	D0
Name	NC5_LS [15:8]							
Type	R/W							

Reset value = 0000 0000

Bit	Name	Function
7:0	NC5_LS [15:8]	<p>NC5_LS [15:8]. See Register 37.</p>

Register 39.

Bit	D7	D6	D5	D4	D3	D2	D1	D0
Name	NC5_LS [7:0]							
Type	R/W							

Reset value = 0011 0001

Bit	Name	Function
7:0	NC5_LS [7:0]	NC5_LS [7:0]. See Register 37.

Register 40.

Bit	D7	D6	D5	D4	D3	D2	D1	D0
Name	N2_HS [2:0]				N2_LS [19:16]			
Type	R/W			R	R/W			

Reset value = 1100 0000

Bit	Name	Function
7:5	N2_HS [2:0]	N2_HS [2:0]. Sets value for N2 high speed divider which drives NCn_LS (n = 1 to 4) low-speed divider. 000:4 001:5 010:6 011:7 100:8 101:9 110:10 111:11.
4	Reserved	
3:0	N2_LS [19:16]	NC2_LS [19:0]. Sets value for N2 low-speed divider, which drives phase detector. 00000000000000000001 = 2 00000000000000000011 = 4 00000000000000000101 = 6 ... 11111111111111111111 = 2^{20} Valid divider values = [2, 4, 6, ..., 2^{20}].

Register 41.

Bit	D7	D6	D5	D4	D3	D2	D1	D0
Name	N2_LS [15:8]							
Type	R/W							

Reset value = 0000 0000

Bit	Name	Function
7:0	N2_LS [15:8]	N2_LS [15:8]. See Register 40.

Register 42.

Bit	D7	D6	D5	D4	D3	D2	D1	D0
Name	N2_LS [7:0]							
Type	R/W							

Reset value = 1111 1001

Bit	Name	Function
7:0	N2_LS [7:0]	N2_LS [7:0]. See Register 40.

Register 43.

Bit	D7	D6	D5	D4	D3	D2	D1	D0
Name						N31 [18:16]		
Type	R	R	R	R	R	R/W		

Reset value = 0000 0000

Bit	Name	Function
7:3	Reserved	
2:0	N31 [18:0]	N31 [18:0]. Sets value for input divider for CKIN1. 00000000000000000000 = 1 00000000000000000001 = 2 00000000000000000010 = 3 ... 11111111111111111111 = 2^{19} Valid divider values = [1, 2, 3, ..., 2^{19}].

Register 44.

Bit	D7	D6	D5	D4	D3	D2	D1	D0
Name	N31 [15:8]							
Type	R/W							

Reset value = 0000 0000

Bit	Name	Function
7:0	N31 [15:8]	N31 [15:8]. See Register 43.

Register 45.

Bit	D7	D6	D5	D4	D3	D2	D1	D0
Name	N31 [7:0]							
Type	R/W							

Reset value = 0000 1001

Bit	Name	Function
7:0	N31 [7:0]	N31 [7:0]. See Register 43.

Register 46.

Bit	D7	D6	D5	D4	D3	D2	D1	D0
Name							N32_[18:16]	
Type	R	R	R	R	R		R/W	

Reset value = 0000 0000

Bit	Name	Function
7:3	Reserved	
2:0	N32_[18:0]	N32_[18:0]. Sets value for input divider for CKIN2. 00000000000000000000 = 1 00000000000000000001 = 2 00000000000000000010 = 3 ... 11111111111111111111 = 2 ¹⁹ Valid divider values=[1, 2, 3, ..., 2 ¹⁹].

Register 47.

Bit	D7	D6	D5	D4	D3	D2	D1	D0
Name	N32_[15:8]							
Type	R/W							

Reset value = 0000 0000

Bit	Name	Function
7:0	N32_[15:8]	N32_[15:8]. See Register 46.

Register 48.

Bit	D7	D6	D5	D4	D3	D2	D1	D0
Name	N32_[7:0]							
Type	R/W							

Reset value = 0000 1001

Bit	Name	Function
7:0	N32_[7:0]	N32_[7:0]. See Register 46.

Register 49.

Bit	D7	D6	D5	D4	D3	D2	D1	D0
Name	N33_[18:0]							
Type	R	R	R	R	R	R/W		

Reset value = 0000 0000

Bit	Name	Function
18:0	N33_[18:0]	N33_[18:0]. Sets value for input divider for CKIN3. 00000000000000000000 = 1 00000000000000000001 = 2 00000000000000000010 = 3 ... 11111111111111111111 = 2^{19} Valid divider values = [1, 2, 3, ..., 2^{19}].

Register 50.

Bit	D7	D6	D5	D4	D3	D2	D1	D0
Name	N33_[15:8]							
Type	R/W							

Reset value = 0000 0000

Bit	Name	Function
7:0	N33_[15:8]	N33_[15:8]. See Register 49.

Register 51.

Bit	D7	D6	D5	D4	D3	D2	D1	D0
Name	N33_[7:0]							
Type	R/W							

Reset value = 0000 1001

Bit	Name	Function
7:0	N33_[7:0]	N33_[7:0]. See Register 49.

Register 52.

Bit	D7	D6	D5	D4	D3	D2	D1	D0
Name							N34_[18:16]	
Type	R	R	R	R	R		R/W	

Reset value = 0000 0000

Bit	Name	Function
7:0	N34_[18:0]	N34_[18:0]. Sets value for input divider for CKIN4. 00000000000000000000 = 1 00000000000000000001 = 2 00000000000000000010 = 3 ... 11111111111111111111 = 2 ¹⁹ Valid divider values = [1, 2, 3, ..., 2 ¹⁹].

Register 53.

Bit	D7	D6	D5	D4	D3	D2	D1	D0
Name	N34_[15:8]							
Type	R/W							

Reset value = 0000 0000

Bit	Name	Function
7:0	N34_[15:8]	N34_[15:8]. See Register 52.

Register 54.

Bit	D7	D6	D5	D4	D3	D2	D1	D0
Name	N34_[7:0]							
Type	R/W							

Reset value = 0000 1001

Bit	Name	Function
7:0	N34_[15:8]	N34_[7:0]. See Register 52.

Register 55.

Bit	D7	D6	D5	D4	D3	D2	D1	D0
Name			CLKIN2RATE_[2:0]			CLKIN1RATE[2:0]		
Type	R	R	R/W			R/W		

Reset value = 0000 0000

Bit	Name	Function
7:6	Reserved	
5:3	CLKIN2RATE[2:0]	CLKIN2RATE[2:0]. CKINn frequency selection for FOS alarm monitoring. 000: 10–27 MHz 001: 25–54 MHz 002: 50–105 MHz 003: 95–215 MHz 004: 190–435 MHz 005: 375–710 MHz 006: Reserved 007: Reserved
2:0	CLKIN1RATE [2:0]	CLKIN1RATE[2:0]. CKINn frequency selection for FOS alarm monitoring. 000: 10–27 MHz 001: 25–54 MHz 002: 50–105 MHz 003: 95–215 MHz 004: 190–435 MHz 005: 375–710 MHz 006: Reserved 007: Reserved

Register 56.

Bit	D7	D6	D5	D4	D3	D2	D1	D0
Name			CLKIN4RATE_[2:0]			CLKIN3RATE[2:0]		
Type	R	R	R/W			R/W		

Reset value = 0000 0000

Bit	Name	Function
7:6	Reserved	
5:3	CLKIN4RATE[2:0]	CLKIN4RATE[2:0]. CKINn frequency selection for FOS alarm monitoring. 000: 10–27 MHz 001: 25–54 MHz 002: 50–105 MHz 003: 95–215 MHz 004: 190–435 MHz 005: 375–710 MHz 006: Reserved 007: Reserved
2:0	CLKIN3RATE [2:0]	CLKIN3RATE[2:0]. CKINn frequency selection for FOS alarm monitoring. 000: 10–27 MHz 001: 25–54 MHz 002: 50–105 MHz 003: 95–215 MHz 004: 190–435 MHz 005: 375–710 MHz 006: Reserved 007: Reserved

Register 128.

Bit	D7	D6	D5	D4	D3	D2	D1	D0
Name					CK4_ACTV_REG	CK3_ACTV_REG	CK2_ACTV_REG	CK1_ACTV_REG
Type	R	R	R	R	R	R	R	R

Reset value = 0010 0000

Bit	Name	Function
7:4	Reserved	
3	CK4_ACTV_REG	CK4_ACTV_REG. Indicates if CKIN4 is currently the active clock for the PLL input. 0: CKIN4 is not the active input clock. Either it is not selected or LOS4_INT is 1. 1: CKIN_4 is the active input clock.
2	CK3_ACTV_REG	CK3_ACTV_REG. Indicates if CKIN3 is currently the active clock for the PLL input. 0: CKIN3 is not the active input clock - either it is not selected or LOS3_INT is 1. 1: CKIN3 is the active input clock.
1	CK2_ACTV_REG	CK2_ACTV_REG. Indicates if CKIN2 is currently the active clock for the PLL input. 0: CKIN2 is not the active input clock. Either it is not selected or LOS2_INT is 1. 1: CKIN2 is the active input clock.
0	CK1_ACTV_REG	CK1_ACTV_REG. Indicates if CKIN1 is currently the active clock for the PLL input. 0: CKIN1 is not the active input clock. Either it is not selected or LOS1_INT is 1. 1: CKIN1 is the active input clock.

Register 129.

Bit	D7	D6	D5	D4	D3	D2	D1	D0
Name				LOS4_INT	LOS3_INT	LOS2_INT	LOS1_INT	LOSX_INT
Type	R	R	R	R	R	R	R	R

Reset value = 0001 1110

Bit	Name	Function
7:5	Reserved	
4	LOS4_INT	LOS4_INT. Indicates the LOS status on CKIN4. 0: Normal operation. 1: Internal loss-of-signal alarm on CKIN4 input.
3	LOS3_INT	LOS3_INT. Indicates the LOS status on CKIN3. 0: Normal operation. 1: Internal loss-of-signal alarm on CKIN3 input.
2	LOS2_INT	LOS2_INT. Indicates the LOS status on CKIN2. 0: Normal operation. 1: Internal loss-of-signal alarm on CKIN2 input.
1	LOS1_INT	LOS1_INT. Indicates the LOS status on CKIN1. 0: Normal operation. 1: Internal loss-of-signal alarm on CKIN1 input.
0	LOSX_INT	LOSX_INT. Indicates the LOS status of the external reference on the XA/XB pins. 0: Normal operation. 1: Internal loss-of-signal alarm on XA/XB reference clock input.

Register 130.

Bit	D7	D6	D5	D4	D3	D2	D1	D0
Name	CLAT-PROGRESS	DIGHOLD-VALID	ALIGN_INT	FOS4_INT	FOS3_INT	FOS2_INT	FOS1_INT	LOL_INT
Type	R	R	R	R	R	R	R	R

Reset value = 0000 0001

Bit	Name	Function
7	CLATPROGRESS	CLAT Progress. Indicates if the last change in the CLAT register has been processed. 0: Coarse skew adjustment not in progress. 1: Coarse skew adjustment in progress.
6	DIGHOLDVALID	Digital Hold Valid. Indicates if the digital hold circuit has enough samples of a valid clock to meet digital hold specifications. 0: Indicates digital filter has not been filled. The digital hold output frequency (from the filter) is not valid. 1: Indicates digital hold filter has been filled. The digital hold output frequency is valid.
5	ALIGN_INT	ALIGN_INT. Alignment Alarm Status. 0: Normal operation. 1: Alignment alarm between input and output frame sync signals.
4	FOS4_INT	FOS4_INT. CKIN4 Frequency Offset Status. 0: Normal operation. 1: Internal frequency offset alarm on CKIN4 input.
3	FOS3_INT	FOS3_INT. CKIN3 Frequency Offset Status. 0: Normal operation. 1: Internal frequency offset alarm on CKIN3 input.
2	FOS2_INT	FOS2_INT. CKIN2 Frequency Offset Status. 0: Normal operation. 1: Internal frequency offset alarm on CKIN2 input.
1	FOS1_INT	FOS1_INT. CKIN1 Frequency Offset Status. 0: Normal operation. 1: Internal frequency offset alarm on CKIN1 input.
0	LOL_INT	LOL_INT. PLL Loss of Lock Status. 0: PLL locked. 1: PLL unlocked.

Register 131.

Bit	D7	D6	D5	D4	D3	D2	D1	D0
Name				LOS4_FLG	LOS3_FLG	LOS2_FLG	LOS1_FLG	LOSX_FLG
Type	R	R	R	R/W	R/W	R/W	R/W	R/W

Reset value = 0001 1111

Bit	Name	Function
7:5	Reserved	
4	LOS4_FLG	<p>LOS4_FLG. CKIN4 Loss-of-Signal Flag. 0: Normal operation. 1: Held version of LOS4_INT. Generates active output interrupt if output interrupt pin is enabled (INT_PIN=1) and if not masked by LOS4_MSK bit. Flag cleared by writing location to 0.</p>
3	LOS3_FLG	<p>LOS3_FLG. CKIN3 Loss-of-Signal Flag. 0: Normal operation. 1: Held version of LOS3_INT. Generates active output interrupt if output interrupt pin is enabled (INT_PIN=1) and if not masked by LOS3_MSK bit. Flag cleared by writing location to 0.</p>
2	LOS2_FLG	<p>LOS2_FLG. CKIN2 Loss-of-Signal Flag. 0: Normal operation. 1: Held version of LOS2_INT. Generates active output interrupt if output interrupt pin is enabled (INT_PIN=1) and if not masked by LOS2_MSK bit. Flag cleared by writing location to 0.</p>
1	LOS1_FLG	<p>LOS1_FLG. CKIN1 Loss-of-Signal Flag. 0: Normal operation. 1: Held version of LOS1_INT. Generates active output interrupt if output interrupt pin is enabled (INT_PIN=1) and if not masked by LOS1_MSK bit. Flag cleared by writing location to 0.</p>
0	LOSX_FLG	<p>LOSX_FLG. External reference (signal on pins XA/XB) Loss-of-Signal Flag. 0: Normal operation. 1: Held version of LOSX_INT. Generates active output interrupt if output interrupt pin is enabled (INT_PIN=1) and if not masked by LOSX_MSK bit. Flag cleared by writing location to 0.</p>

Register 132.

Bit	D7	D6	D5	D4	D3	D2	D1	D0
Name		ALIGN_FLG	FOS4_FLG	FOS3_FLG	FOS2_FLG	FOS1_FLG	LOL_FLG	ALIGN_ERR [8,8]
Type	R	R/W	R/W	R/W	R/W	R/W	R/W	R

Reset value = 0000 0010

Bit	Name	Function
7	Reserved	
6	ALIGN_FLG	ALIGN_FLG. Alignment Alarm Flag. 0: Normal operation. 1: Held version of ALIGN_INT. Generates active output interrupt if output interrupt pin is enabled (INT_PIN=1) and if not masked by ALIGN_MSK bit. Flag cleared by writing location to 0.
5	FOS4_FLG	FOS4_FLG. CLKIN_4 Frequency Offset Flag. 0: Normal operation. 1: Held version of FOS4_INT. Generates active output interrupt if output interrupt pin is enabled (INT_PIN=1) and if not masked by FOS4_MSK bit. Flag cleared by writing location to 0.
4	FOS3_FLG	FOS3_FLG. CLKIN_3 Frequency Offset Flag. 0: Normal operation. 1: Held version of FOS3_INT. Generates active output interrupt if output interrupt pin is enabled (INT_PIN=1) and if not masked by FOS3_MSK bit. Flag cleared by writing location to 0.
3	FOS2_FLG	FOS2_FLG. CLKIN_2 Frequency Offset Flag. 0: Normal operation. 1: Held version of FOS2_INT. Generates active output interrupt if output interrupt pin is enabled (INT_PIN = 1) and if not masked by FOS2_MSK bit. Flag cleared by writing location to 0.

Bit	Name	Function
2	FOS1_FLG	<p>FOS1_FLG. CLKIN_1 Frequency Offset Flag. 0: Normal operation. 1: Held version of FOS1_INT. Generates active output interrupt if output interrupt pin is enabled (INT_PIN = 1) and if not masked by FOS1_MSK bit. Flag cleared by writing location to 0.</p>
1	LOL_FLG	<p>LOL_FLG. PLL Loss of Lock Flag. 0: PLL locked 1: Held version of LOL_INT. Generates active output interrupt if output interrupt pin is enabled (INT_PIN = 1) and if not masked by LOL_MSK bit. Flag cleared by writing location to 0.</p>
0	ALIGN_ERR [8,8]	<p>ALIGN_ERR [8:0]. Indicates the magnitude of the deviation of the input to output frame sync phase alignment from the ideal value set in the FSYNC_SKEW[16:0] registers. The alignment error is given in units of tCKOUT_2. If the alignment error exceeds 255 fCKOUT_2 clock cycles, ALIGN_ERR[7:0] limits to its maximum value (11111111). The polarity of the phase deviation (leading or lagging) is given by the ALIGN_ERR[8] bit. 00000000=0 11111111=255</p>

Register 133.

Bit	D7	D6	D5	D4	D3	D2	D1	D0
Name	ALIGN_ERR [7:0]							
Type	R							

Reset value = 0000 0000

Bit	Name	Function
7:0	ALIGN_ERR [7:0]	<p>ALIGN_ERR [7:0]. See Register 132.</p>

Register 134.

Bit	D7	D6	D5	D4	D3	D2	D1	D0
Name	PARTNUM_RO [11:4]							
Type	R							

Reset value = 0000 0100

Bit	Name	Function
7:0	PARTNUM_RO [11:4]	PARTNUM_RO [11:4]. Device ID: 0000 0100 0100'b=Si5368

Register 135.

Bit	D7	D6	D5	D4	D3	D2	D1	D0
Name	PARTNUM_RO [3:0]				REVID_RO [3:0]			
Type	R				R			

Reset value = 0100 0010

Bit	Name	Function
7:4	PARTNUM_RO [3:0]	PARTNUM_RO [3:0]. See Register 134.
3:0	REVID_RO [3:0]	REVID_RO [3:0]. Indicates revision number of device. 0000: Revision A 0001: Revision B 0010: Revision C Other codes: Reserved

Register 136.

Bit	D7	D6	D5	D4	D3	D2	D1	D0
Name	RST_REG	ICAL						
Type	R/W	R/W	R	R	R	R	R	R

Reset value = 0000 0000

Bit	Name	Function
7	RST_REG	<p>RST_REG. Internal Reset. 0: Normal operation. 1: Reset of all internal logic. Outputs tristated or disabled during reset.</p>
6	ICAL	<p>ICAL. Start an Internal Calibration Sequence. For proper operation, the device must go through an internal calibration sequence. ICAL is a self-clearing bit. Writing a one to this location initiates an ICAL. The calibration is complete once the LOL alarm goes low. A valid stable clock (within 100 ppm) must be present to begin ICAL. Note: Any divider, CLKINn_RATE or BWSEL_REG changes require an ICAL to take effect. Changes in SFOUTn_REG, PD_CKn, or DSBLn_REG will cause a random change in skew until an ICAL is completed. 0: Normal operation. 1: Writing a “1” initiates internal self-calibration. Upon completion of internal self-calibration, ICAL is internally reset to zero.</p>
5:0	Reserved	

Register 138.

Bit	D7	D6	D5	D4	D3	D2	D1	D0
Name					LOS4_EN [1:1]	LOS3_EN [1:1]	LOS2_EN [1:1]	LOS1_EN [1:1]
Type	R	R	R	R	R/W	R/W	R/W	R/W

Reset value = 0000 1111

Bit	Name	Function
7:4	Reserved	
3	LOS4_EN [1:0]	<p>LOS4_EN [1:0]. Note: LOS1_EN is split between two registers. 00: Disable LOS monitoring. 01: Reserved. 10: Enable LOSA monitoring. 11: Enable LOS monitoring. LOSA is a slower and less sensitive version of LOS. See the Family Reference Manual for details.</p>
2	LOS3_EN [1:0]	<p>LOS3_EN [1:0]. Note: LOS1_EN is split between two registers. 00: Disable LOS monitoring. 01: Reserved. 10: Enable LOSA monitoring. 11: Enable LOS monitoring. LOSA is a slower and less sensitive version of LOS. See the Family Reference Manual for details.</p>
1	LOS2_EN [1:0]	<p>LOS2_EN [1:0]. Note: LOS1_EN is split between two registers. 00: Disable LOS monitoring. 01: Reserved. 10: Enable LOSA monitoring. 11: Enable LOS monitoring. LOSA is a slower and less sensitive version of LOS. See the Family Reference Manual for details.</p>
0	LOS1_EN [1:0]	<p>LOS1_EN [1:0]. Note: LOS1_EN is split between two registers. 00: Disable LOS monitoring. 01: Reserved. 10: Enable LOSA monitoring. 11: Enable LOS monitoring. LOSA is a slower and less sensitive version of LOS. See the Family Reference Manual for details.</p>

Register 139.

Bit	D7	D6	D5	D4	D3	D2	D1	D0
Name	LOS4_EN [0:0]	LOS3_EN [0:0]	LOS2_EN [0:0]	LOS1_EN [0:0]	FOS4_EN	FOS3_EN	FOS2_EN	FOS1_EN
Type	R/W	R/W	R/W	R/W	R/W	R/W	R/W	R/W

Reset value = 1111 1111

Bit	Name	Function
7	LOS4_EN [0:0]	<p>LOS4_EN [0:0]. Enable CKIN1 LOS Monitoring on the Specified Input (1 of 2). Note: LOS1_EN is split between two registers. 00: Disable LOS monitoring. 01: Reserved. 10: Enable LOSA monitoring. 11: Enable LOS monitoring. LOSA is a slower and less sensitive version of LOS. See the family reference manual for details.</p>
6	LOS3_EN [0:0]	<p>LOS3_EN [0:0]. Enable CKIN1 LOS Monitoring on the Specified Input (1 of 2). Note: LOS1_EN is split between two registers. 00: Disable LOS monitoring. 01: Reserved. 10: Enable LOSA monitoring. 11: Enable LOS monitoring. LOSA is a slower and less sensitive version of LOS. See the family reference manual for details.</p>
5	LOS2_EN [0:0]	<p>LOS2_EN. Enable CKIN1 LOS Monitoring on the Specified Input (1 of 2). Note: LOS1_EN is split between two registers. 00: Disable LOS monitoring. 01: Reserved. 10: Enable LOSA monitoring. 11: Enable LOS monitoring. LOSA is a slower and less sensitive version of LOS. See the family reference manual for details.</p>
4	LOS1_EN [0:0]	<p>LOS1_EN [0:0]. Enable CKIN1 LOS Monitoring on the Specified Input (1 of 2). Note: LOS1_EN is split between two registers. 00: Disable LOS monitoring. 01: Reserved. 10: Enable LOSA monitoring. 11: Enable LOS monitoring. LOSA is a slower and less sensitive version of LOS. See the family reference manual for details.</p>

Bit	Name	Function
3	FOS4_EN	FOS4_EN. Enables FOS on a Per Channel Basis. 0: Disable FOS monitoring. 1: Enable FOS monitoring.
2	FOS3_EN	FOS3_EN. Enables FOS on a Per Channel Basis. 0: Disable FOS monitoring. 1: Enable FOS monitoring.
1	FOS2_EN	FOS2_EN. Enables FOS on a Per Channel Basis. 0: Disable FOS monitoring. 1: Enable FOS monitoring.
0	FOS1_EN	FOS1_EN. Enables FOS on a Per Channel Basis. 0: Disable FOS monitoring. 1: Enable FOS monitoring.

Register 140.

Bit	D7	D6	D5	D4	D3	D2	D1	D0
Name	INDEPENDENTSKEW1 [7:0]							
Type	R/W							

Reset value = 0000 0000

Bit	Name	Function
7:0	INDEPEND-ENTSKEW1 [7:0]	INDEPENDENTSKEW1 [7:0]. 8 bit field that represents a twos complement of the phase offset in terms of clocks from the high speed output divider.

Register 141.

Bit	D7	D6	D5	D4	D3	D2	D1	D0
Name	INDEPENDENTSKEW2 [7:0]							
Type	R/W							

Reset value = 0000 0001

Bit	Name	Function
7:0	INDEPEND-ENTSKEW2 [7:0]	INDEPENDENTSKEW2 [7:0]. 8 bit field that represents a twos complement of the phase offset in terms of clocks from the high speed output divider.

Register 142.

Bit	D7	D6	D5	D4	D3	D2	D1	D0
Name	INDEPENDENTSKEW3 [7:0]							
Type	R/W							

Reset value = 0000 0000

Bit	Name	Function
7:0	INDEPEND-ENTSKEW3 [7:0]	INDEPENDENTSKEW3 [7:0]. 8 bit field that represents a twos complement of the phase offset in terms of clocks from the high speed output divider.

Register 143.

Bit	D7	D6	D5	D4	D3	D2	D1	D0
Name	INDEPENDENTSKEW4 [7:0]							
Type	R/W							

Reset value = 0000 0000

Bit	Name	Function
7:0	INDEPEND-ENTSKEW4 [7:0]	INDEPENDENTSKEW4 [7:0]. 8 bit field that represents a twos complement of the phase offset in terms of clocks from the high speed output divider.

Register 144.

Bit	D7	D6	D5	D4	D3	D2	D1	D0
Name	INDEPENDENTSKEW5 [7:0]							
Type	R/W							

Reset value = 0000 0000

Bit	Name	Function
7:0	INDEPEND-ENTSKEW5 [7:0]	INDEPENDENTSKEW5 [7:0]. 8 bit field that represents a twos complement of the phase offset in terms of clocks from the high speed output divider when CK_CONFIG = 0.

Table 9. CKOUT_ALWAYS_ON and SQICAL Truth Table

CKOUT_ALWAYS_ON	SQICAL	Results	Output to Output Skew Preserved?
0	0	CKOUT OFF until after the first ICAL	N
0	1	CKOUT OFF until after the first successful ICAL (i.e., when LOL is low)	Y
1	0	CKOUT always ON, including during an ICAL	N
1	1	CKOUT always ON, including during an ICAL	Y

Table 10 lists all of the register locations that should be followed by an ICAL after their contents are changed.

Table 10. Register Locations Requiring ICAL

Address	Register
0	BYPASS_REG
0	CKOUT_ALWAYS_ON
1	CK_PRIOR4
1	CK_PRIOR3
1	CK_PRIOR2
1	CK_PRIOR1
2	BWSEL_REG
4	HIST_DEL
5	ICMOS
7	FOSREFSEL
9	HIST_AVG
10	DSBL5_REG
10	DSBL4_REG
10	DSBL3_REG
10	DSBL2_REG
10	DSBL1_REG
11	PD_CK2
11	PD_CK1
19	FOS_EN
19	FOS_THR
19	VALTIME
19	LOCKT
21	INCDEC_PIN
25	N1_HS
26	NC1_LS
28	NC2_LS
31	NC3_LS
34	NC4_LS
37	NC5_LS
40	N2_HS
40	N2_LS
43	N31
46	N32
49	N33
51	N34
55	CLKIN2RATE
55	CLKIN1RATE
56	CLKIN4RATE
56	CLKIN3RATE

7. Pin Descriptions: Si5368

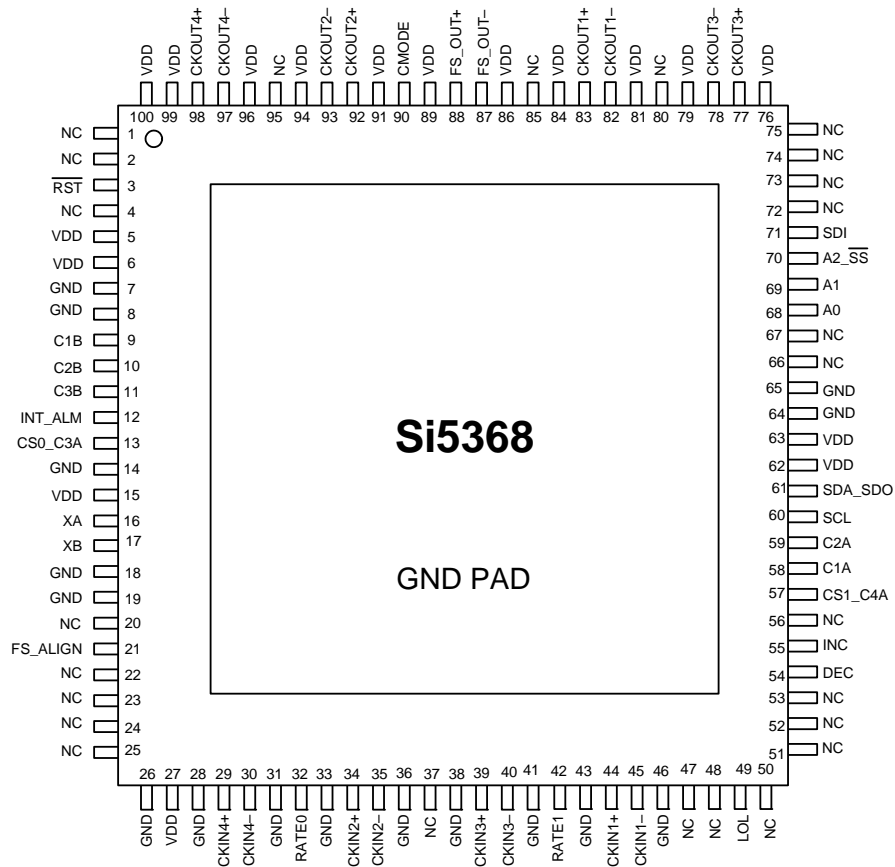

Table 11. Si5368 Pin Descriptions

Pin #	Pin Name	I/O	Signal Level	Description																				
1, 2, 4, 20, 22, 23, 24, 25, 37, 47, 48, 50, 51, 52, 53, 56, 66, 67, 72, 73, 74, 75, 80, 85, 95	NC			No Connect. These pins must be left unconnected for normal operation.																				
3	$\overline{\text{RST}}$	I	LVC MOS	External Reset. Active low input that performs external hardware reset of device. Resets all internal logic to a known state and forces the device registers to their default value. Clock outputs are disabled during reset. The part must be programmed after a reset or power-on to get a clock output. See Family Reference Manual for details. This pin has a weak pull-up.																				
5, 6, 15, 27, 62, 63, 76, 79, 81, 84, 86, 89, 91, 94, 96, 99, 100	V _{DD}	V _{DD}	Supply	V_{DD}. The device operates from a 1.8, 2.5, or 3.3 V supply. Bypass capacitors should be associated with the following V _{DD} pins: <table border="1"> <thead> <tr> <th>Pins</th> <th>Bypass Cap</th> </tr> </thead> <tbody> <tr> <td>5, 6</td> <td>0.1 μF</td> </tr> <tr> <td>15</td> <td>0.1 μF</td> </tr> <tr> <td>27</td> <td>0.1 μF</td> </tr> <tr> <td>62, 63</td> <td>0.1 μF</td> </tr> <tr> <td>76, 79</td> <td>1.0 μF</td> </tr> <tr> <td>81, 84</td> <td>0.1 μF</td> </tr> <tr> <td>86, 89</td> <td>0.1 μF</td> </tr> <tr> <td>91, 94</td> <td>0.1 μF</td> </tr> <tr> <td>96, 99, 100</td> <td>0.1 μF</td> </tr> </tbody> </table>	Pins	Bypass Cap	5, 6	0.1 μF	15	0.1 μF	27	0.1 μF	62, 63	0.1 μF	76, 79	1.0 μF	81, 84	0.1 μF	86, 89	0.1 μF	91, 94	0.1 μF	96, 99, 100	0.1 μF
Pins	Bypass Cap																							
5, 6	0.1 μF																							
15	0.1 μF																							
27	0.1 μF																							
62, 63	0.1 μF																							
76, 79	1.0 μF																							
81, 84	0.1 μF																							
86, 89	0.1 μF																							
91, 94	0.1 μF																							
96, 99, 100	0.1 μF																							
7, 8, 14, 18, 19, 26, 28, 31, 33, 36, 38, 41, 43, 46, 64, 65	GND	GND	Supply	Ground. This pin must be connected to system ground. Minimize the ground path impedance for optimal performance.																				
9	C1B	O	LVC MOS	CKIN1 Invalid Indicator. This pin performs the <i>CK1_BAD</i> function if <i>CK1_BAD_PIN</i> = 1 and is tristated if <i>CK1_BAD_PIN</i> = 0. Active polarity is controlled by <i>CK_BAD_POL</i> . 0 = No alarm on CKIN1. 1 = Alarm on CKIN1.																				
10	C2B	O	LVC MOS	CKIN2 Invalid Indicator. This pin performs the <i>CK2_BAD</i> function if <i>CK2_BAD_PIN</i> = 1 and is tristated if <i>CK2_BAD_PIN</i> = 0. Active polarity is controlled by <i>CK_BAD_POL</i> . 0 = No alarm on CKIN2. 1 = Alarm on CKIN2.																				
Note: Internal register names are indicated by underlined italics, e.g. <i>INT_PIN</i> . See Si5368 Register Map.																								

Table 11. Si5368 Pin Descriptions (Continued)

Pin #	Pin Name	I/O	Signal Level	Description										
11	C3B	O	LVC MOS	<p>CKIN3 Invalid Indicator. This pin performs the <i>CK3_BAD</i> function if <i>CK3_BAD_PIN</i> = 1 and is tristated if <i>CK3_BAD_PIN</i> = 0. Active polarity is controlled by <i>CK_BAD_POL</i>. 0 = No alarm on CKIN3. 1 = Alarm on CKIN3.</p>										
12	INT_ALM	O	LVC MOS	<p>Interrupt/Alarm Output Indicator. This pin functions as a maskable interrupt output with active polarity controlled by the <i>INT_POL</i> register bit. The INT output function can be turned off by setting <i>INT_PIN</i> = 0. If the ALRM-OUT function is desired instead on this pin, set <i>ALRMOUT_PIN</i> = 1 and <i>INT_PIN</i> = 0. 0 = <i>ALRMOUT</i> not active. 1 = <i>ALRMOUT</i> active. The active polarity is controlled by <i>CK_BAD_POL</i>. If no function is selected, the pin tristates.</p>										
13 57	CS0_C3A CS1_C4A	I/O	LVC MOS	<p>Input Clock Select/CKIN3 or CKIN4 Active Clock Indicator. Input: If manual clock selection is chosen, and if <i>CKSEL_PIN</i> = 1, the CKSEL pins control clock selection and the <i>CKSEL_REG</i> bits are ignored.</p> <table border="1" data-bbox="852 947 1349 1182"> <thead> <tr> <th>CS[1:0]</th> <th>Active Input Clock</th> </tr> </thead> <tbody> <tr> <td>00</td> <td>CKIN1</td> </tr> <tr> <td>01</td> <td>CKIN2</td> </tr> <tr> <td>10</td> <td>CKIN3</td> </tr> <tr> <td>11</td> <td>CKIN4</td> </tr> </tbody> </table> <p>If <i>CKSEL_PIN</i> = 0, the <i>CKSEL_REG</i> register bits control this function and these inputs tristate. If configured as inputs, these pins must not float. Output: If auto clock selection is enabled, then they serve as the CKIN_n active clock indicator. 0 = CKIN3 (CKIN4) is not the active input clock 1 = CKIN3 (CKIN4) is currently the active input to the PLL The <i>CKn_ACTV_REG</i> bit always reflects the active clock status for CKIN_n. If <i>CKn_ACTV_PIN</i> = 1, this status will also be reflected on the CnA pin with active polarity controlled by the <i>CK_ACTV_POL</i> bit. If <i>CKn_ACTV_PIN</i> = 0, this output tristates.</p>	CS[1:0]	Active Input Clock	00	CKIN1	01	CKIN2	10	CKIN3	11	CKIN4
CS[1:0]	Active Input Clock													
00	CKIN1													
01	CKIN2													
10	CKIN3													
11	CKIN4													
16 17	XA XB	I	ANALOG	<p>External Crystal or Reference Clock. External crystal should be connected to these pins to use internal oscillator based reference. Refer to Family Reference Manual for interfacing to an external reference. External reference must be from a high-quality clock source (TCXO, OCXO). Frequency of crystal or external clock is set by the RATE pins.</p>										

Note: Internal register names are indicated by underlined italics, e.g. *INT_PIN*. See Si5368 Register Map.

Table 11. Si5368 Pin Descriptions (Continued)

Pin #	Pin Name	I/O	Signal Level	Description
21	FS_ALIGN	I	LVC MOS	FSYNC Alignment Control. If <i>FSYNC_ALIGN_PIN</i> = 1 and <i>CK_CONFIG</i> = 1, a logic high on this pin causes the FS_OUT phase to be realigned to the rising edge of the currently active input sync (CKIN_3 or CKIN_4). If <i>FSYNC_ALIGN_PIN</i> = 0, this pin is ignored and the <i>FSYNC_ALIGN_REG</i> bit performs this function. 0 = No realignment. 1 = Realign. This pin has a weak pull-down.
29 30	CKIN4+ CKIN4–	I	MULTI	Clock Input 4. Differential clock input. This input can also be driven with a single-ended signal. CKIN4 serves as the frame sync input associated with the CKIN2 clock when <i>CK_CONFIG_REG</i> = 1.
32 42	RATE0 RATE1	I	3-Level	External Crystal or Reference Clock Rate. Three level inputs that select the type and rate of external crystal or reference clock to be applied to the XA/XB port. Refer to the Family Reference Manual for settings. These pins have both a weak pull-up and a weak pull-down; they default to M.
34 35	CKIN2+ CKIN2–	I	MULTI	Clock Input 2. Differential input clock. This input can also be driven with a single-ended signal.
39 40	CKIN3+ CKIN3–	I	MULTI	Clock Input 3. Differential clock input. This input can also be driven with a single-ended signal. CKIN3 serves as the frame sync input associated with the CKIN1 clock when <i>CK_CONFIG_REG</i> = 1.
44 45	CKIN1+ CKIN1–	I	MULTI	Clock Input 1. Differential clock input. This input can also be driven with a single-ended signal.
49	LOL	O	LVC MOS	PLL Loss of Lock Indicator. This pin functions as the active high PLL loss of lock indicator if the <i>LOL_PIN</i> register bit is set to one. 0 = PLL locked. 1 = PLL unlocked. If <i>LOL_PIN</i> = 0, this pin will tristate. Active polarity is controlled by the <i>LOL_POL</i> bit. The PLL lock status will always be reflected in the <i>LOL_INT</i> read only register bit.
Note: Internal register names are indicated by underlined italics, e.g. <i>INT_PIN</i> . See Si5368 Register Map.				

Table 11. Si5368 Pin Descriptions (Continued)

Pin #	Pin Name	I/O	Signal Level	Description
54	DEC	I	LVC MOS	<p>Coarse Latency Decrement. A pulse on this pin decreases the input to output device latency by $1/f_{OSC}$ (approximately 200 ps). Detailed operations and timing characteristics for this pin may be found in the Any-Frequency Precision Clock Family Reference Manual. There is no limit on the range of latency adjustment by this method. Pin control is enabled by setting <i>INCDEC_PIN</i> = 1 (default). If <i>INCDEC_PIN</i> = 0, this pin is ignored and coarse output latency is controlled via the CLAT register. If both INC and DEC are tied high, phase buildout is disabled and the device maintains a fixed-phase relationship between the selected input clock and the output clock during an input clock switch. Detailed operations and timing characteristics for these pins may be found in the Any-Frequency Precision Clock Family Reference Manual. This pin has a weak pull-down.</p>
55	INC	I	LVC MOS	<p>Coarse Latency Increment. A pulse on this pin increases the input to output device latency by $1/f_{OSC}$ (approximately 200 ps). Detailed operations, restrictions, and timing characteristics for this pin may be found in the Any-Frequency Precision Clock Family Reference Manual. There is no limit on the range of latency adjustment by this method. Pin control is enabled by setting <i>INCDEC_PIN</i> = 1 (default). Note: INC does not increase latency if NI_HS = 4. If <i>INCDEC_PIN</i> = 0, this pin is ignored and coarse output latency is controlled via the CLAT register. If both INC and DEC are tied high, phase buildout is disabled and the device maintains a fixed-phase relationship between the selected input clock and the output clock during an input clock switch. Detailed operations and timing characteristics for these pins may be found in the Any-Frequency Precision Clock Family Reference Manual. This pin has a weak pull-down.</p>
58	C1A	O	LVC MOS	<p>CKIN1 Active Clock Indicator. This pin serves as the CKIN1 active clock indicator. The <i>CK1_ACTV_REG</i> bit always reflects the active clock status for CKIN1. If <i>CK1_ACTV_PIN</i> = 1, this status will also be reflected on the C1A pin with active polarity controlled by the <i>CK_ACTV_POL</i> bit. If <i>CK1_ACTV_PIN</i> = 0, this output tristates.</p>
59	C2A	O	LVC MOS	<p>CKIN2 Active Clock Indicator. This pin serves as the CKIN2 active clock indicator. The <i>CK2_ACTV_REG</i> bit always reflects the active clock status for CKIN2. If <i>CK2_ACTV_PIN</i> = 1, this status will also be reflected on the C2A pin with active polarity controlled by the <i>CK_ACTV_POL</i> bit. If <i>CK2_ACTV_PIN</i> = 0, this output tristates.</p>
<p>Note: Internal register names are indicated by underlined italics, e.g. <i>INT_PIN</i>. See Si5368 Register Map.</p>				

Table 11. Si5368 Pin Descriptions (Continued)

Pin #	Pin Name	I/O	Signal Level	Description
60	SCL	I	LVC MOS	Serial Clock. This pin functions as the serial port clock input for both SPI and I ² C modes. This pin has a weak pull-down.
61	SDA_SDO	I/O	LVC MOS	Serial Data. In I ² C microprocessor control mode (CMODE = 0), this pin functions as the bidirectional serial data port. In SPI microprocessor control mode (CMODE = 1), this pin functions as the serial data output.
68 69	A0 A1	I	LVC MOS	Serial Port Address. In I ² C microprocessor control mode (CMODE = 0), these pins function as hardware controlled address bits. The I ² C address is 1101 [A2] [A1] [A0]. In SPI microprocessor control mode (CMODE = 1), these pins are ignored. This pin has a weak pull-down.
70	A2_SS	I	LVC MOS	Serial Port Address/Slave Select. In I ² C microprocessor control mode (CMODE = 0), this pin functions as a hardware controlled address bit [A2]. In SPI microprocessor control mode (CMODE = 1), this pin functions as the slave select input. This pin has a weak pull-down.
71	SDI	I	LVC MOS	Serial Data In. In SPI microprocessor control mode (CMODE = 1), this pin functions as the serial data input. In I ² C microprocessor control mode (CMODE = 0), this pin is ignored. This pin has a weak pull-down.
77 78	CKOUT3+ CKOUT3-	O	MULTI	Clock Output 3. Differential clock output. Output signal format is selected by <i>SFOUT3_REG</i> register bits. Output is differential for LVPECL, LVDS, and CML compatible modes. For CMOS format, both output pins drive identical single-ended clock outputs.
82 83	CKOUT1- CKOUT1+	O	MULTI	Clock Output 1. Differential clock output. Output signal format is selected by <i>SFOUT1_REG</i> register bits. Output is differential for LVPECL, LVDS, and CML compatible modes. For CMOS format, both output pins drive identical single-ended clock outputs.
87 88	FS_OUT- FS_OUT+	O	MULTI	Frame Sync Output. Differential frame sync output or fifth high-speed clock output. Output signal format is selected by <i>SFOUT_FS_SYNC_REG</i> register bits. Output is differential for LVPECL, LVDS, and CML compatible modes. For CMOS format, both output pins drive identical single-ended clock outputs. Duty cycle and active polarity are controlled by <i>FSYNC_PW</i> and <i>FSYNC_POL</i> bits, respectively. Detailed operations and timing characteristics for these pins may be found in the Any-Frequency Precision Clock Family Reference Manual.
Note: Internal register names are indicated by underlined italics, e.g. <i>INT_PIN</i> . See Si5368 Register Map.				

Table 11. Si5368 Pin Descriptions (Continued)

Pin #	Pin Name	I/O	Signal Level	Description
90	CMODE	I	LVC MOS	Control Mode. Selects I ² C or SPI control mode for the device. 0 = I ² C Control Mode. 1 = SPI Control Mode. This pin must be tied high or low.
92 93	CKOUT2+ CKOUT2-	O	MULTI	Clock Output 2. Differential clock output. Output signal format is selected by <i>SFOUT2_REG</i> register bits. Output is differential for LVPECL, LVDS, and CML compatible modes. For CMOS format, both output pins drive identical single-ended clock outputs.
97 98	CKOUT4- CKOUT4+	O	MULTI	Clock Output 4. Differential clock output. Output signal format is selected by <i>SFOUT4_REG</i> register bits. Output is differential for LVPECL, LVDS, and CML compatible modes. For CMOS format, both output pins drive identical single-ended clock outputs.
GND PAD	GND PAD	GND	Supply	Ground Pad. The ground pad must provide a low thermal and electrical impedance to a ground plane.
Note: Internal register names are indicated by underlined italics, e.g. <i>INT_PIN</i> . See Si5368 Register Map.				

8. Ordering Guide

Ordering Part Number	Output Clock Frequency Range	Package	ROHS6, Pb-Free	Temperature Range
Si5368A-C-GQ	2 kHz–945 MHz 970–1134 MHz 1.213–1.417 GHz	100-Pin 14 x 14 mm TQFP	Yes	–40 to 85 °C
Si5368B-C-GQ	2 kHz–808 MHz	100-Pin 14 x 14 mm TQFP	Yes	–40 to 85 °C
Si5368C-C-GQ	2 kHz–346 MHz	100-Pin 14 x 14 mm TQFP	Yes	–40 to 85 °C

Note: Add an R at the end of the device to denote tape and reel options (for example, Si5368-C-GMR).

9. Package Outline: 100-Pin TQFP

Figure 6 illustrates the package details for the Si5368. Table 12 lists the values for the dimensions shown in the illustration.



Figure 6. 100-Pin Thin Quad Flat Package (TQFP)

Table 12. 100-Pin Package Diagram Dimensions

Dimension	Min	Nom	Max	Dimension	Min	Nom	Max
A	—	—	1.20	E	16.00 BSC.		
A1	0.05	—	0.15	E1	14.00 BSC.		
A2	0.95	1.00	1.05	E2	3.85	4.00	4.15
b	0.17	0.22	0.27	L	0.45	0.60	0.75
c	0.09	—	0.20	aaa	—	—	0.20
D	16.00 BSC.			bbb	—	—	0.20
D1	14.00 BSC.			ccc	—	—	0.08
D2	3.85	4.00	4.15	ddd	—	—	0.08
e	0.50 BSC.			θ	0°	3.5°	7°

Notes:

1. All dimensions shown are in millimeters (mm) unless otherwise noted.
2. Dimensioning and Tolerancing per ANSI Y14.5M-1994.
3. This package outline conforms to JEDEC MS-026, variant AED-HD.
4. Recommended card reflow profile is per the JEDEC/IPC J-STD-020C specification for Small Body Components.

10. Recommended PCB Layout



Figure 7. PCB Land Pattern Diagram

Table 13. PCB Land Pattern Dimensions

Dimension	MIN	MAX
e	0.50 BSC.	
E	15.40 REF.	
D	15.40 REF.	
E2	3.90	4.10
D2	3.90	4.10
GE	13.90	—
GD	13.90	—
X	—	0.30
Y	1.50 REF.	
ZE	—	16.90
ZD	—	16.90
R1	0.15 REF	
R2	—	1.00

Notes:**General**

1. All dimensions shown are in millimeters (mm) unless otherwise noted.
2. Dimensioning and Tolerancing is per the ANSI Y14.5M-1994 specification.
3. This Land Pattern Design is based on IPC-7351 guidelines.
4. All dimensions shown are at Maximum Material Condition (MMC). Least Material Condition (LMC) is calculated based on a Fabrication Allowance of 0.05 mm.

Solder Mask Design

5. All metal pads are to be non-solder mask defined (NSMD). Clearance between the solder mask and the metal pad is to be 60 μ m minimum, all the way around the pad.

Stencil Design

6. A stainless steel, laser-cut and electro-polished stencil with trapezoidal walls should be used to assure good solder paste release.
7. The stencil thickness should be 0.125 mm (5 mils).
8. The ratio of stencil aperture to land pad size should be 1:1 for the perimeter pads.
9. A 4 x 4 array of 0.80 mm square openings on 1.05 mm pitch should be used for the center ground pad.

Card Assembly

10. A No-Clean, Type-3 solder paste is recommended.
11. The recommended card reflow profile is per the JEDEC/IPC J-STD-020 specification for Small Body Components.

Si5368

11. Top Marking: 100-Pin TQFP

11.1. Si5368 Top Marking



11.2. Top Marking Explanation

Mark Method:	Laser	
Logo Size:	9.2 x 3.1 mm Center-Justified	
Font Size:	3.0 Point (1.07 mm) Right-Justified	
Line 1 Marking:	Device Part Number	X = Speed Grade See "7. Pin Descriptions: Si5368" on page 79.
Line 2 Marking:	YY = Year WW = Workweek R=Die Revision	Assigned by the Assembly Supplier. Corresponds to the year and work-week of the mold date.
	TTTTT = Mfg Code	Manufacturing Code
Line 3 Marking:	Circle = 1.8 mm Diameter Center-Justified	"e3" Pb-Free Symbol
	Country of Origin ISO Code Abbreviation	

DOCUMENT CHANGE LIST

Revision 0.1 to Revision 0.2

- Changed LVTTTL to LVCMOS in Table 9, “Absolute Maximum Ratings,” on page 18.
- Updated Figure 4 and Figure 5 on page 19.
- Updated “5. Register Map”.
 - Added RATE0 to pin description. By changing RATE[1:0] the part can emulate a Si5367.
 - Changed XA/XB pin description to support both differential and single ended external REFCLK.

Revision 0.2 to Revision 0.3

- Added Figure on p..8.
- Updated Figure 4, “Si5368 Typical Application Circuit (I²C Control Mode),” and Figure 5, “Si5368 Typical Application Circuit (SPI Control Mode),” on page 19 to show INC and DEC.
- Updated “5. Register Map”.
 - Changed font of register names to *underlined italics*.
- Updated “7. Pin Descriptions: Si5368” on page 79.
- Added “10. Recommended PCB Layout”.

Revision 0.3 to Revision 0.4

- Changed V_{DD} specification for 1.8 V.
- Updated Table 8 on page 16.
- Updated Table 9 on page 18.
- Added table under Figure on page 8.
- Updated “4. Functional Description” on page 20.
- Clarified “5. Register Map” on page 22 including correcting pin assignments for RATE0 and RATE1.

Revision 0.4 to Revision 0.41

- Added register map.
- Added 3.3 V operation.
- Removed some TBDs from the AC specifications.

Revision 0.41 to Revision 1.0

- Expanded spec tables.
- Added device top mark drawing.
- Changed “any-rate” to “any-frequency” throughout.
- Added No Bypass mode with CMOS outputs.
- Minor updates to Table 2 on page 4 and Table 6 on page 14.
- Removed “2. Typical Phase Noise Performance”.
- Updated “4. Functional Description” on page 20.
- Revised “5. Register Map” on page 22.
- Revised “11. Top Marking: 100-Pin TQFP” on page 90.

CONTACT INFORMATION

Silicon Laboratories Inc.

400 West Cesar Chavez
Austin, TX 78701
Tel: 1+(512) 416-8500
Fax: 1+(512) 416-9669
Toll Free: 1+(877) 444-3032

Please visit the Silicon Labs Technical Support web page:
<https://www.silabs.com/support/pages/contacttechnicalsupport.aspx>
and register to submit a technical support request.

The information in this document is believed to be accurate in all respects at the time of publication but is subject to change without notice. Silicon Laboratories assumes no responsibility for errors and omissions, and disclaims responsibility for any consequences resulting from the use of information included herein. Additionally, Silicon Laboratories assumes no responsibility for the functioning of undescribed features or parameters. Silicon Laboratories reserves the right to make changes without further notice. Silicon Laboratories makes no warranty, representation or guarantee regarding the suitability of its products for any particular purpose, nor does Silicon Laboratories assume any liability arising out of the application or use of any product or circuit, and specifically disclaims any and all liability, including without limitation consequential or incidental damages. Silicon Laboratories products are not designed, intended, or authorized for use in applications intended to support or sustain life, or for any other application in which the failure of the Silicon Laboratories product could create a situation where personal injury or death may occur. Should Buyer purchase or use Silicon Laboratories products for any such unintended or unauthorized application, Buyer shall indemnify and hold Silicon Laboratories harmless against all claims and damages.

Silicon Laboratories, Silicon Labs, and DSPLL are trademarks of Silicon Laboratories Inc.
Other products or brandnames mentioned herein are trademarks or registered trademarks of their respective holders.

Компания «Life Electronics» занимается поставками электронных компонентов импортного и отечественного производства от производителей и со складов крупных дистрибьюторов Европы, Америки и Азии.

С конца 2013 года компания активно расширяет линейку поставок компонентов по направлению коаксиальный кабель, кварцевые генераторы и конденсаторы (керамические, пленочные, электролитические), за счёт заключения дистрибьюторских договоров

Мы предлагаем:

- Конкурентоспособные цены и скидки постоянным клиентам.
- Специальные условия для постоянных клиентов.
- Подбор аналогов.
- Поставку компонентов в любых объемах, удовлетворяющих вашим потребностям.
- Приемлемые сроки поставки, возможна ускоренная поставка.
- Доставку товара в любую точку России и стран СНГ.
- Комплексную поставку.
- Работу по проектам и поставку образцов.
- Формирование склада под заказчика.
- Сертификаты соответствия на поставляемую продукцию (по желанию клиента).
- Тестирование поставляемой продукции.
- Поставку компонентов, требующих военную и космическую приемку.
- Входной контроль качества.
- Наличие сертификата ISO.

В составе нашей компании организован Конструкторский отдел, призванный помогать разработчикам, и инженерам.

Конструкторский отдел помогает осуществить:

- Регистрацию проекта у производителя компонентов.
- Техническую поддержку проекта.
- Защиту от снятия компонента с производства.
- Оценку стоимости проекта по компонентам.
- Изготовление тестовой платы монтаж и пусконаладочные работы.



Тел: +7 (812) 336 43 04 (многоканальный)

Email: org@lifeelectronics.ru