

Multiband Chip Antenna

ACAJ-109-T

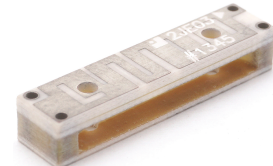

RoHS / RoHS II Compliant



24.0 x 5.5 x 4.4 mm

Moisture Sensitivity Level (MSL) – MSL = 1

FEATURES:

- Passive Penta-Band antenna (824MHz ~ 2170MHz)
- Covering GSM850, GSM900, DCS, PCS, & UMTS
- SMA mount, Reflowable to 260 degrees C max.
- Dimensions (24.0mm x 5.5mm x 4.4mm)
- Peak Gain variable across bands from 1.3 ~ 6.4dBi
- VSWR 3.0:1 Max (measured on matched EV board)
- Impedance 50 Ohms
- Linear Polarization / Omni-directional azimuth pattern
- RoHS/RoHS II compliant
- 2J Technology

APPLICATIONS:

- GSM850/900MHz
- DCS
- PCS
- UMTS
- Embedded applications

STANDARD SPECIFICATIONS

Description

The ACAJ-109-T product is a multi-band antenna that can be tuned to different bands by modifying its matching circuit. The antenna is constructed from a dielectric ceramic material with Ag patterns to form the antenna performance.

Electrical Characteristics for GSM850

ITEM		SPECIFICATION			
Frequency Range		824 ~ 894MHz			
VSWR		3.5: 1 Max			
Polarization		Linear			
Azimuth Beam Pattern		Omni-directional			
Impedance		50Ω			
Operating Temperature		-35°C to + 85°C			
Frequency [MHz]		824	849	869	894
Gain [dBi]	Peak	-0.3	-0.2	0.4	1.3
	Average	-3.7	-3.6	-3.3	-2.5
Efficiency [%]		42.4	43.8	47.1	56.1

Electrical Characteristics for GSM900

ITEM		SPECIFICATION			
Frequency Range		880 ~ 960MHz			
VSWR		3.5: 1 Max			
Polarization		Linear			
Azimuth Beam Pattern		Omni-directional			
Impedance		50Ω			
Operating Temperature		-35°C to + 85°C			
Frequency [MHz]		880	915	925	960
Gain [dBi]	Peak	1.5	2.2	2.4	1.8
	Average	-2.4	-1.9	-1.8	-2.3
Efficiency [%]		57.3	64.6	65.8	58.2

Multiband Chip Antenna

ACAJ-109-T

 RoHS / RoHS II Compliant 

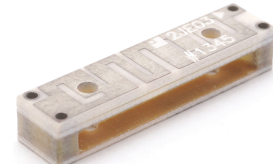

24.0 x 5.5 x 4.4 mm

STANDARD SPECIFICATIONS

Electrical Characteristics for DCS1800

ITEM		SPECIFICATION			
Frequency Range		1710 ~ 1880MHz			
VSWR		3.0 : 1 Max			
Polarization		Linear			
Azimuth Beam Pattern		Omni-directional			
Impedance		50Ω			
Operating Temperature		-35°C to + 85°C			
Frequency [MHz]		1710	1785	1805	1880
Gain [dBi]	Peak	6.4	5.8	6.1	5.4
	Average	-0.4	-0.9	-0.6	-1.1
Efficiency [%]		90.9	80.7	86.2	76.8

Electrical Characteristics for PCS1900

ITEM		SPECIFICATION			
Frequency Range		1850 ~ 1990MHz			
VSWR		3.0 : 1 Max			
Polarization		Linear			
Azimuth Beam Pattern		Omni-directional			
Impedance		50Ω			
Operating Temperature		-35°C to + 85°C			
Frequency [MHz]		1850	1910	1930	1990
Gain [dBi]	Peak	5.6	5.9	5.8	5.5
	Average	-0.8	-0.5	-0.5	-0.6
Efficiency [%]		84.0	89.8	88.6	86.7

Electrical Characteristics for UMTS2100

ITEM		SPECIFICATION			
Frequency Range		920~2170MHz			
VSWR		3.0 : 1 Max			
Polarization		Linear			
Azimuth Beam Pattern		Omni-directional			
Impedance		50Ω			
Operating Temperature		-35°C to + 85°C			
Frequency [MHz]		1920	1980	2110	2170
Gain [dBi]	Peak	4.8	4.5	4.6	4.5
	Average	-0.7	-0.9	-0.5	-0.2
Efficiency [%]		84.9	82.1	89.5	95.4

Multiband Chip Antenna

ACAJ-109-T

Pb | RoHS / RoHS II Compliant | 

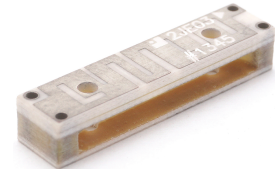

24.0 x 5.5 x 4.4 mm

PART IDENTIFICATION:

ACAJ-109-

Packaging

Blank: Bulk

T: Tape and Reel

S11 (VSWR)- Penta Band (GSM850&900, DCS, PCS, UMTS)

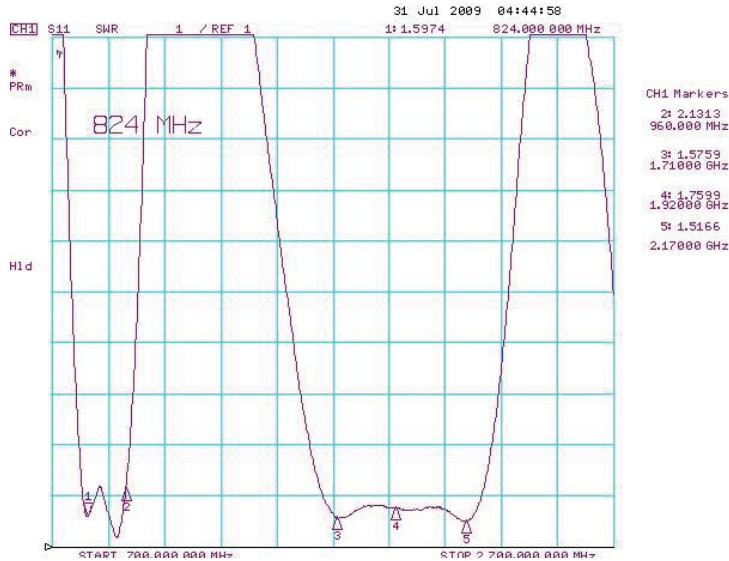

VSWR on EV Board

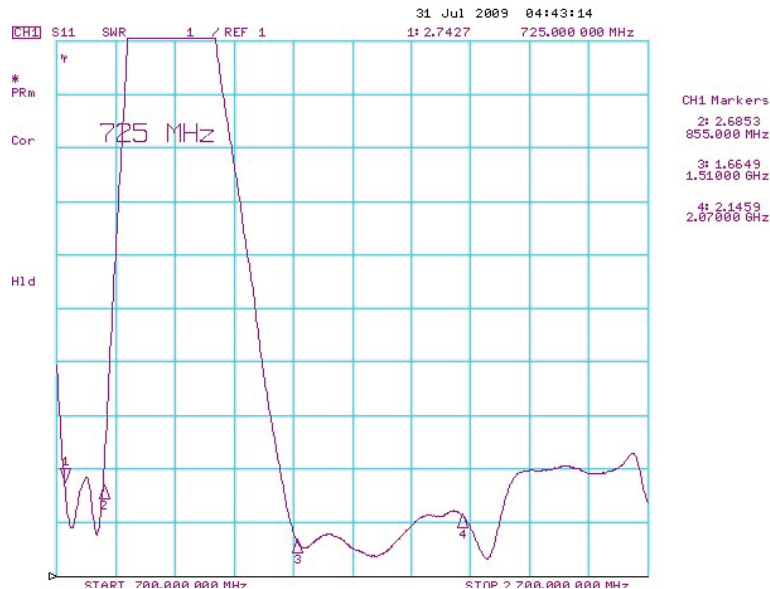

VSWR @ Manual Jig

Multiband Chip Antenna

ACAJ-109-T

RoHS / RoHS II Compliant

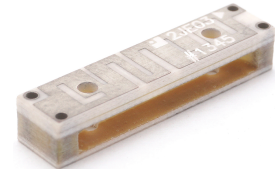

24.0 x 5.5 x 4.4 mm

OUTLINE DIMENSION:

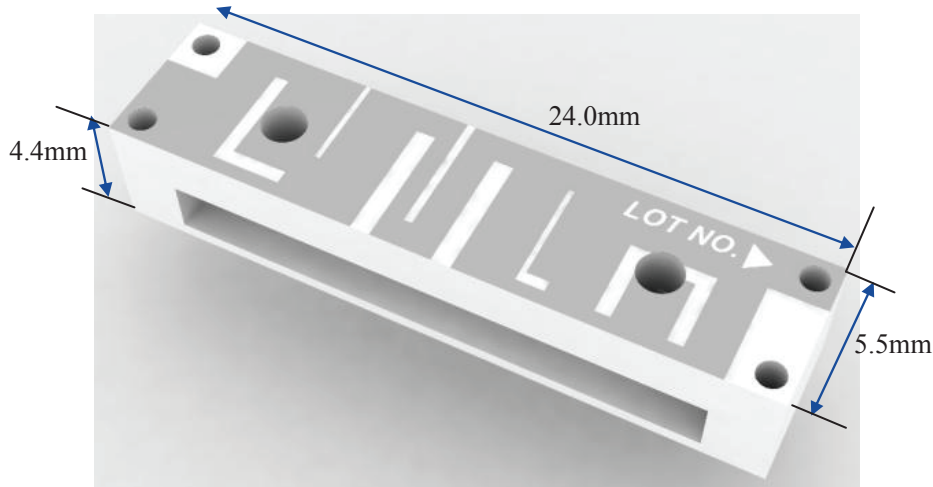

Tolerance: ± 0.15

Recommended Land Pattern

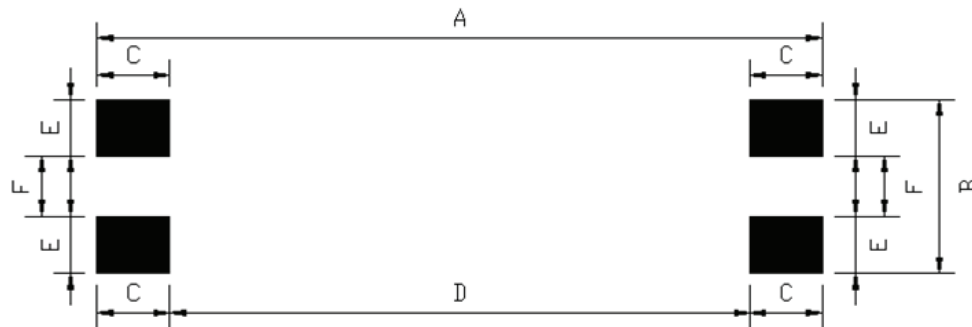

A	B	C	D	E	F
25.0	5.5	2.3	20.4	1.8	1.9

Unit: mm.1

REFLOW PROFILE:

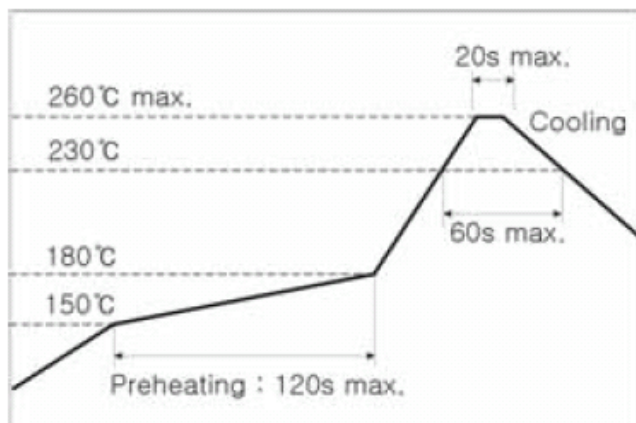

This product is designed for reflow soldering only. Do not use flow (wave) soldering. Use non-activated flux (Cl content 0.2% max.) Follow the recommended soldering conditions to avoid damage. Reflow-cycle is max. 3 times.

Multiband Chip Antenna

ACAJ-109-T

 RoHS / RoHS II Compliant 

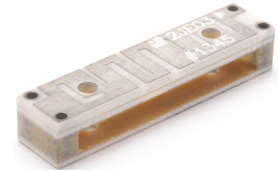

24.0 x 5.5 x 4.4 mm

TAPE & REEL:

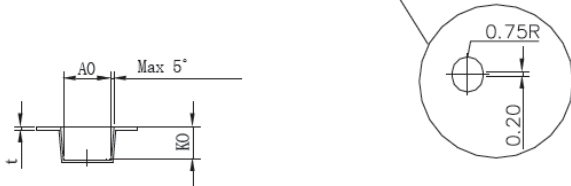
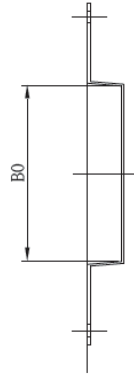
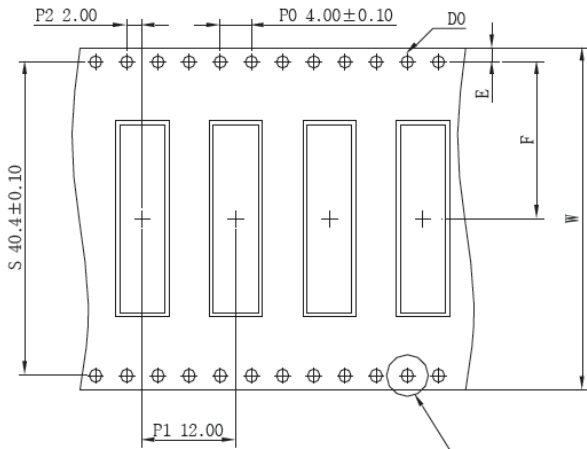

A0	5.80±0.20	E	1.75±0.10
B0	24.30±0.20	F	20.20± 0.20
K0	4.60±0.20	W	44.00±0.30
D0	1.55±0.05	t	0.40±0.05

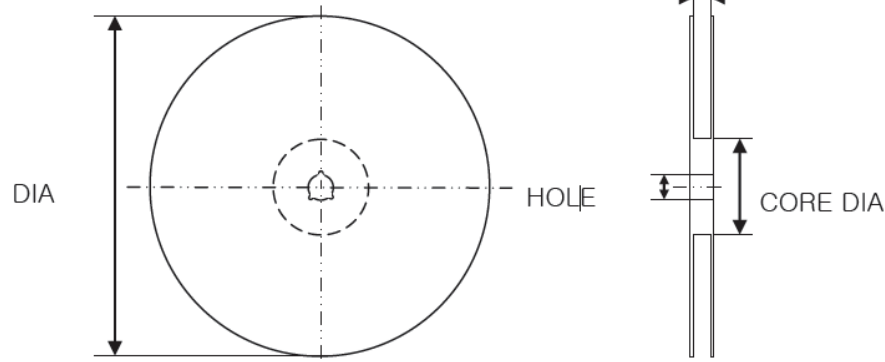

Item	Size (mm)
DIA	330.0 ± 2
WIDTH	45.5 ± 0.5
CORE DIA	100.0 ± 1
HOLE	13.0 ± 0.3

Package Quantity: 1000units/reel

ATTENTION: Abracon Corporation's products are COTS – Commercial-Off-The-Shelf products; suitable for Commercial, Industrial and, where designated, Automotive Applications. Abracon's products are not specifically designed for Military, Aviation, Aerospace, Life-dependant Medical applications or any application requiring high reliability where component failure could result in loss of life and/or property. For applications requiring high reliability and/or presenting an extreme operating environment, written consent and authorization from Abracon Corporation is required. Please contact Abracon Corporation for more information.

ABRACON IS
ISO9001:2008
CERTIFIED

 **ABRACON**[®] LLC
The Power of Linking Together

2 Faraday, Suite# B | Irvine | CA 92618 **Revised: 11.19.15**
Ph. 949.546.8000 | Fax. 949.546.8001

Visit www.abracon.com for Terms and Conditions of Sale

Компания «Life Electronics» занимается поставками электронных компонентов импортного и отечественного производства от производителей и со складов крупных дистрибьюторов Европы, Америки и Азии.

С конца 2013 года компания активно расширяет линейку поставок компонентов по направлению коаксиальный кабель, кварцевые генераторы и конденсаторы (керамические, пленочные, электролитические), за счёт заключения дистрибьюторских договоров

Мы предлагаем:

- Конкурентоспособные цены и скидки постоянным клиентам.
- Специальные условия для постоянных клиентов.
- Подбор аналогов.
- Поставку компонентов в любых объемах, удовлетворяющих вашим потребностям.
- Приемлемые сроки поставки, возможна ускоренная поставка.
- Доставку товара в любую точку России и стран СНГ.
- Комплексную поставку.
- Работу по проектам и поставку образцов.
- Формирование склада под заказчика.
- Сертификаты соответствия на поставляемую продукцию (по желанию клиента).
- Тестирование поставляемой продукции.
- Поставку компонентов, требующих военную и космическую приемку.
- Входной контроль качества.
- Наличие сертификата ISO.

В составе нашей компании организован Конструкторский отдел, призванный помогать разработчикам, и инженерам.

Конструкторский отдел помогает осуществить:

- Регистрацию проекта у производителя компонентов.
- Техническую поддержку проекта.
- Защиту от снятия компонента с производства.
- Оценку стоимости проекта по компонентам.
- Изготовление тестовой платы монтаж и пусконаладочные работы.



Тел: +7 (812) 336 43 04 (многоканальный)

Email: org@lifeelectronics.ru