

K-no.: 24512

15 A Current Sensor for 5V- Supply Voltage
Date: 30.01.2012

 For electronic current measurement:
 DC, AC, pulsed, mixed ..., with a galvanic
 isolation between primary circuit
 (high power) and secondary circuit
 (electronic circuit)

Customer: Standard type

Customers Part no.:

Page 1 of 2

Description

- Closed loop (compensation)
Current Sensor with magnetic field probe
- Printed circuit board mounting
- Casing and materials UL-listed

Characteristics

- Excellent accuracy
- Very low offset current
- Very low temperature dependency and offset current drift
- Very low hysteresis of offset current
- Short response time
- Wide frequency bandwidth
- Compact design
- Reduced offset ripple

Applications

Mainly used for stationary operation in industrial applications:

- AC variable speed drives and servo motor drives
- Static converters for DC motor drives
- Battery supplied applications
- Switched Mode Power Supplies (SMPS)
- Power Supplies for welding applications
- Uninterruptible Power Supplies (UPS)

Electrical data – Ratings

I_{PN}	Primary nominal r.m.s. current	15	A
V_{out}	Output voltage @ I_P	$V_{Ref} \pm (0.625 \cdot I_P / I_{PN})$	V
V_{out}	Output voltage @ $I_P=0, T_A=25^\circ C$	$V_{Ref} \pm 0.008$	V
V_{Ref}	External Reference voltage range	0...4	V
	Internal Reference voltage	2.5 ± 0.005	V
K_N	Turns ratio	1...3 : 2000	

Accuracy – Dynamic performance data

		min.	typ.	max.	Unit
$I_{P,max}$	Max. measuring range	±51			
X	Accuracy @ $I_{PN}, T_A=25^\circ C$			0.7	%
ϵ_L	Linearity			0.1	%
$V_{out} - V_{Ref}$	Offset voltage @ $I_P=0, T_A=25^\circ C$			±8	mV
$\Delta V_o / V_{Ref} / \Delta T$	Temperature drift of V_{out} @ $I_P=0, V_{Ref}=2,5V, T_A=-40...85^\circ C$	6		20	ppm/°C
t_r	Response time @ 90% von I_{PN}		300		ns
$\Delta t (I_{P,max})$	Delay time at $di/dt = 100 A/\mu s$		200		ns
f	Frequency bandwidth	DC...100			kHz

General data

		min.	typ.	max.	Unit
T_A	Ambient operating temperature	-40		+85	°C
T_S	Ambient storage temperature	-40		+85	°C
m	Mass		12		g
V_C	Supply voltage	4.75	5	5.25	V
I_C	Current consumption		15		mA

 Constructed and manufactured and tested in accordance with EN 61800-5-1 (Pin 1 - 6 to Pin 7 - 10)
 Reinforced insulation, Insulation material group 1, Pollution degree 2

S_{clear}	Clearance (component without solder pad)	7,4			mm
S_{creep}	Creepage (component without solder pad)	8,0			mm
V_{sys}	System voltage	overvoltage category 3	RMS	300	V
V_{work}	Working voltage	(tabel 7 acc. to EN61800-5-1) overvoltage category 2	RMS	650	V
U_{PD}	Rated discharge voltage	peak value		1320	V

 According UL 840: $V_{sys} = 600 V$

Date	Name	Issue	Amendment
30.01.12	Le	82	Values for clearance and creepage accordance UL 840 added. AA-444
28.01.11	Le	82	Date changed.

Hrsg.: KB-E editor	Bearb.: Le designer	KB-PM: Ga. check	freig.: HS released
-----------------------	------------------------	---------------------	------------------------

K-no.: 24512

15 A Current Sensor for 5V- Supply Voltage

For electronic current measurement:
DC, AC, pulsed, mixed ..., with a galvanic
isolation between primary circuit
(high power) and secondary circuit
(electronic circuit)

Date: 30.01.2012

Customer: Standard type

Customers Part no.:

Page 2 of 2

Mechanical outline (mm):

General tolerances DIN ISO 2768-c

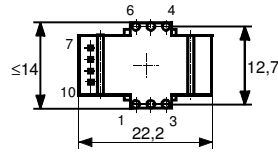

Toleranz der Stiftabstände
±0,2 mm
(Tolerances grid distance)

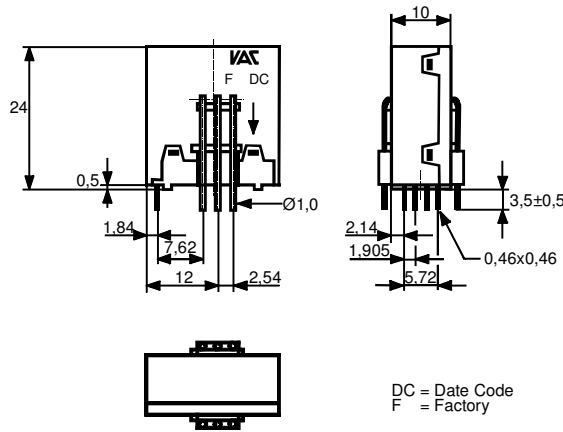

DC = Date Code
F = Factory

Connections:

1...6: Ø 1 mm
7..10: 0,46*0,46 mm

Marking:

VAC
4646X662
F DC

Schematic diagram

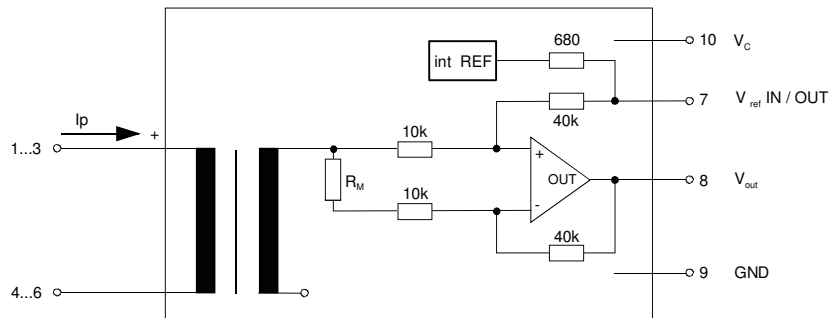

Possibilities of wiring

(@ TA = 85 °C)

primary windings	primary current RMS	primary current maximal	output current RMS	turns ratio	primary resistance	wiring
N _P	I _P [A]	I _{P,max} [A]	I _S (I _P) [mA]	K _N	R _P [mΩ]	
1	15	±51	2.5±0.625	1:2000	0.33	
2	7.5	±25	2.5±0.625	2:2000	1.5	
3	5	±17	2.5±0.625	3:2000	3	

Temperature of the primary conductor should not exceed 110 °C.
Additional information is obtainable on request.
This specification is no declaration of warranty acc. BGB §443 dar.

Hrsg.: KB-E
editor

Bearb: Le
designer

KB-PM: Ga.
check

freig.: HS
released

K-No.: 24512

15 A Current Sensor for 5V-Supply Voltage

 For the electronic measurement of currents:
 DC, AC, pulsed, mixed ..., with a galvanic
 isolation between the primary circuit
 (high power) and the secondary circuit

Date: 30.01.2012

Customer:

Customers Part No.:

Page 1 of 2

Electrical Data

		min.	typ.	max.	Unit
V_{Ctot}	Maximum supply voltage (without function)			6	V
I_C	Supply Current with primary current	15mA + $I_p \cdot K_N + V_{out}/R_L$			mA
$I_{out,SC}$	Short circuit output current		±20		mA
R_P	Resistance / primary winding @ $T_A=25^\circ C$		1		mΩ
R_S	Secondary coil resistance @ $T_A=85^\circ C$			67	Ω
$R_{i,Ref}$	Internal resistance of Reference input		670		Ω
$R_{i,(V_{out})}$	Output resistance of V_{out}			1	Ω
R_L	External recommended resistance of V_{out}	1			kΩ
C_L	External recommended capacitance of V_{out}			500	pF
$\Delta X_{Ti} / \Delta T$	Temperature drift of X @ $T_A = -40 \dots +85^\circ C$			40	ppm/K
$\Delta V_0 = \Delta(V_{out} - V_{Ref})$	Sum of any offset drift including:		3.5	10	mV
V_{0t}	Longtermdrift of V_0		2		mV
V_{0T}	Temperature drift von V_0 @ $T_A = -40 \dots +85^\circ C$		2		mV
V_{0H}	Hysteresis of V_{out} @ $I_p=0$ (after an overload of $10 \times I_{PN}$)		3		mV
$\Delta V_0 / \Delta V_C$	Supply voltage rejection ratio			1	mV/V
V_{oss}	Offsetripple (with 1 MHz- filter first order)			30	mV
V_{oss}	Offsetripple (with 100 kHz- filter first order)		4	8	mV
V_{oss}	Offsetripple (with 20 kHz- filter first order)		1.2	2	mV
C_k	Maximum possible coupling capacity (primary – secondary)		5	10	pF
	Mechanical stress according to M3209/3			30g	
	Settings: 10 – 2000 Hz, 1 min/Decade, 2 hours				

Inspection (Measurement after temperature balance of the samples at room temperature)

$V_{out} (I_p=I_{PN})$	(V) M3011/6:	Output voltage vs. external reference ($I_p=15A, 40-80Hz$)	625±0.7%	mV
$V_{out}-V_{Ref} (I_p=0)$	(V) M3226:	Offset voltage	± 0.008	V
V_d	(V) M3014:	Test voltage, rms, 1 s pin 1 – 6 vs. pin 7 – 10	1.5	kV
V_e	(AQL 1/S4)	Partial discharge voltage acc.M3024 (RMS) with V_{vor} (RMS)	1400 1750	V V

Type Testing (Pin 1 - 6 to Pin 7 - 10)

Designed according standard EN 50178 with insulation material group 1

V_W	HV transient test according to M3064 (1,2 μs / 50 μs-wave form)	8	kV
V_d	Testing voltage to M3014	(5 s)	3 kV
V_e	Partial discharge voltage acc.M3024 (RMS) with V_{vor} (RMS)	1400 1750	V V

Applicable documents

 Current direction: A positive output current appears at point I_s , by primary current in direction of the arrow.
 Housing and bobbin material UL-listed: Flammability class 94V-0.
 Enclosures according to IEC529: IP50.

Datum	Name	Index	Amendment
30.01.12	Le	82	Date adapted.
28.01.11	Le	82	Inspection M3011/6: 15A instead of 25A, typo. Lapidary change.

Hrsg.: KB-E editor	Bearb.: Le. designer	KB-PM: KRe check	freig.: HS released
-----------------------	-------------------------	---------------------	------------------------

K-No.: 24512	15 A Current Sensor for 5V-Supply Voltage For the electronic measurement of currents: DC, AC, pulsed, mixed ..., with a galvanic Isolation between the primary circuit (high power) and the secondary circuit	Date: 30.01.2012
--------------	--	------------------

Customer:	Customers Part No.:	Page 2 of 2
-----------	---------------------	-------------

Explanation of several of the terms used in the tablets (in alphabetical order)

t_r : Response time (describe the dynamic performance for the specified measurement range), measured as delay time at $I_P = 0,9 \cdot I_{PN}$ between a rectangular current and the output voltage $V_{out}(I_P)$

$\Delta t(I_{Pmax})$: Delay time (describe the dynamic performance for the rapid current pulse rate e.g short circuit current) measured between I_{Pmax} and the output voltage $V_{out}(I_{Pmax})$ with a primary current rise of $di_P/dt \geq 100 \text{ A}/\mu\text{s}$.

V_0 : Offset voltage between V_{out} and the rated reference voltage of $V_{ref} = 2,5V$.
 $V_0 = V_{out}(0) - 2,5V$

U_{PD} Rated discharge voltage (recurring peak voltage separated by the insulation) proved with a sinusoidal voltage V_e
 $U_{PD} = \sqrt{2} \cdot V_e / 1,5$

V_{vor} Defined voltage is the RMS value of a sinusoidal voltage with peak value of $1,875 \cdot U_{PD}$ required for partial discharge test in IEC 61800-5-1
 $V_{vor} = 1,875 \cdot U_{PD} / \sqrt{2}$

V_{sys} System voltage RMS value of rated voltage according to IEC 61800-5-1

V_{work} Working voltage voltage according to IEC 61800-5-1 which occurs by design in a circuit or across insulation

V_{0H} : Zero variation of V_0 after overloading with a DC of tenfold the rated value

V_{0t} : Long term drift of V_0 after 100 temperature cycles in the range -40 bis 85 °C.

X : Permissible measurement error in the final inspection at RT, defined by
$$X = 100 \cdot \left| \frac{V_{out}(I_{PN}) - V_{out}(0)}{0,625V} - 1 \right| \%$$

$X_{ges}(I_{PN})$: Permissible measurement error including any drifts over the temperature range by the current measurement I_{PN}
$$X_{ges} = 100 \cdot \left| \frac{V_{out}(I_{PN}) - 2,5V}{0,625V} - 1 \right| \%$$
 or
$$X_{ges} = 100 \cdot \left| \frac{V_{out}(I_{PN}) - V_{ref}}{0,625V} - 1 \right| \%$$

ϵ_L : Linearity fault defined by
$$\epsilon_L = 100 \cdot \left| \frac{I_P}{I_{PN}} - \frac{V_{out}(I_P) - V_{out}(0)}{V_{out}(I_{PN}) - V_{out}(0)} \right| \%$$

This "Additional information" is no declaration of warranty according BGB §443.

Hrsg.: KB-E editor	Bearb: Le. designer		KB-PM: KRe check		freig.: HS released
-----------------------	------------------------	--	---------------------	--	------------------------

Компания «Life Electronics» занимается поставками электронных компонентов импортного и отечественного производства от производителей и со складов крупных дистрибьюторов Европы, Америки и Азии.

С конца 2013 года компания активно расширяет линейку поставок компонентов по направлению коаксиальный кабель, кварцевые генераторы и конденсаторы (керамические, пленочные, электролитические), за счёт заключения дистрибьюторских договоров

Мы предлагаем:

- Конкурентоспособные цены и скидки постоянным клиентам.
- Специальные условия для постоянных клиентов.
- Подбор аналогов.
- Поставку компонентов в любых объемах, удовлетворяющих вашим потребностям.
- Приемлемые сроки поставки, возможна ускоренная поставка.
- Доставку товара в любую точку России и стран СНГ.
- Комплексную поставку.
- Работу по проектам и поставку образцов.
- Формирование склада под заказчика.
- Сертификаты соответствия на поставляемую продукцию (по желанию клиента).
- Тестирование поставляемой продукции.
- Поставку компонентов, требующих военную и космическую приемку.
- Входной контроль качества.
- Наличие сертификата ISO.

В составе нашей компании организован Конструкторский отдел, призванный помогать разработчикам, и инженерам.

Конструкторский отдел помогает осуществить:

- Регистрацию проекта у производителя компонентов.
- Техническую поддержку проекта.
- Защиту от снятия компонента с производства.
- Оценку стоимости проекта по компонентам.
- Изготовление тестовой платы монтаж и пусконаладочные работы.



Тел: +7 (812) 336 43 04 (многоканальный)

Email: org@lifeelectronics.ru