

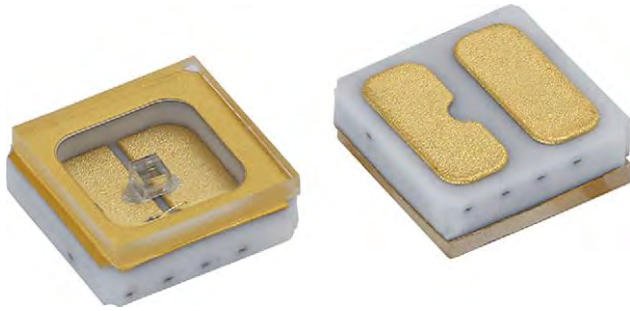

### UVC Emitting Diode in SMD Package



#### DESCRIPTION

VLMU35CL..-280-120 is a ceramic based low power UVC LED with quartz window for long life time. The package size is 3.5 mm x 3.5 mm x 1.2 mm and the radiant power typically 3.2 mW at 20 mA in a wavelength range of 265 nm to 285 nm.

#### PRODUCT GROUP AND PACKAGE DATA

- Product group: LED
- Package: SMD ceramic
- Product series: standard power UV LED
- Angle of half intensity: ± 60°
- Lead-finishing: Au

#### FEATURES

- Ceramic SMT package with quartz window
- Dimension (L x W x H) in mm: 3.5 x 3.5 x 1.2
- Forward current: up to 70 mA
- Radiant power (typ.): 3.2 mW at 20 mA and 7.5 mW at 50 mA
- Leads / terminations finish: gold plated (Au)
- Reflow soldering method
- MSL 3 according to J-STD-020
- Material categorization: for definitions of compliance please see [www.vishay.com/doc?99912](http://www.vishay.com/doc?99912)



#### APPLICATIONS

- Sterilization
- Medical application
- Sensing of gases, germs, DNA, ...

#### SAFETY ADVICES

Depending on the mode of operation, these devices emit highly concentrated non visible ultraviolet light which can be hazardous to the human eye and skin. Products which incorporate these devices have to follow the safety precautions given in IEC 62471 "Photobiological Safety of Lamps and Lamp Systems".

PARTS TABLE														
PART	COLOR	RADIANT POWER (mW)			at I <sub>F</sub>	WAVELENGTH (nm)			at I <sub>F</sub>	FORWARD VOLTAGE (V)			at I <sub>F</sub>	TECHNOLOGY
		MIN.	TYP.	MAX.	(mA)	MIN.	TYP.	MAX.	(mA)	MIN.	TYP.	MAX.	(mA)	
VLMU35CL00-280-120	Ultraviolet	1.8	3.2	-	20	265	278	285	20	4	5	6.5	20	AlGaIn

ABSOLUTE MAXIMUM RATINGS (T <sub>amb</sub> = 25 °C, unless otherwise specified)				
VLMU35CL..-280-120				
PARAMETER	TEST CONDITION	SYMBOL	VALUE	UNIT
DC forward current		I <sub>F</sub>	70	mA
Power dissipation		P <sub>V</sub>	0.45	W
Reverse voltage			Not designed for reverse operation	
Electrostatic discharge	HBM: MIL-STD-883 C 3B	ESD	2000	V
Junction temperature		T <sub>j</sub>	+85	°C
Operating temperature range		T <sub>amb</sub>	-40 to +80	°C
Storage temperature range		T <sub>stg</sub>	-40 to +100	°C
Solder temperature		T <sub>sol</sub>	260	°C

**OPTICAL AND ELECTRICAL CHARACTERISTICS** ( $T_{amb} = 25\text{ }^{\circ}\text{C}$ , unless otherwise specified)  
**VLMU35CL..-280-120, ULTRAVIOLET**

PARAMETER	TEST CONDITION	SYMBOL	MIN.	TYP.	MAX.	UNIT
Forward voltage	$I_F = 20\text{ mA}$	$V_F$	4	5	6.5	V
Radiant power	$I_F = 20\text{ mA}$	$\phi_e$	1.8	3.2	-	mW
	$I_F = 50\text{ mA}$		-	7.5	-	
Ratio of radiant intensity/radiant power	$I_F = 20\text{ mA}$	$I_e/\phi_e$	-	0.25	-	$\text{sr}^{-1}$
Peak wavelength	$I_F = 20\text{ mA}$	$\lambda_p$	265	278	285	nm
Angle of half intensity	$I_F = 20\text{ mA}$	$\varphi$	-	$\pm 60$	-	$^{\circ}$
Thermal resistance junction to ambient	Soldered on 20 x 20 x 1.7 (in mm) Al MCPCB	$R_{thJA}$	-	46	-	K/W

**Note**

- Tolerances:  $\pm 11\%$  for  $\phi_e$ ,  $\pm 0.1\text{ V}$  for  $V_F$ ,  $\pm 3\text{ nm}$  for  $\lambda_p$

**RADIANT POWER CLASSIFICATION** ( $I_F = 20\text{ mA}$ )

GROUP	MIN.	MAX.	UNIT
X2	1.8	2.1	mW
X3	2.1	2.5	
X4	2.5	3.0	
X5	3.0	3.5	
X6	3.5	4.1	
X7	4.1	4.8	
X8	4.8	5.6	

**PEAK WAVELENGTH CLASSIFICATION** ( $I_F = 20\text{ mA}$ )

GROUP	MIN.	MAX.	UNIT
W1	265	285	nm

**FORWARD VOLTAGE CLASSIFICATION** ( $I_F = 20\text{ mA}$ )

GROUP	MIN.	MAX.	UNIT
V1	4.0	4.5	V
V2	4.5	5.0	
V3	5.0	5.5	
V4	5.5	6.0	
V5	6.0	6.5	

**Note**

- In order to ensure availability, single groups for radiant intensity, wavelength, and forward voltage will not be orderable. Only one group for radiant intensity, wavelength, and forward voltage will be shipped in any one reel

**TYPICAL CHARACTERISTICS** ( $T_{amb} = 25\text{ }^{\circ}\text{C}$ , unless otherwise specified)

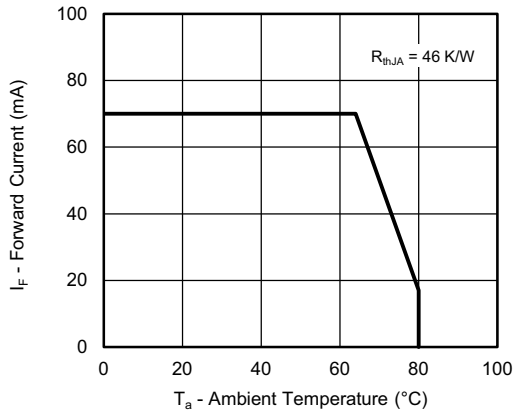

Fig. 1 - Maximum Forward Current vs. Solder Point Temperature

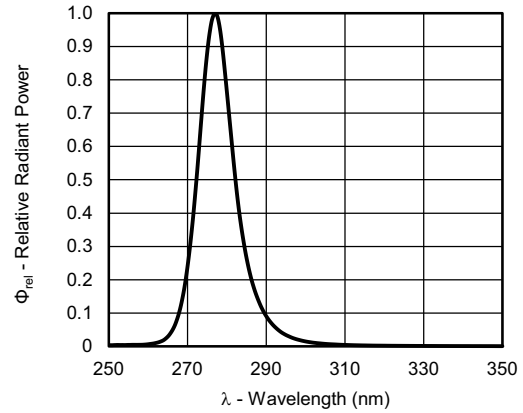

Fig. 4 - Relative Spectral Power vs. Wavelength

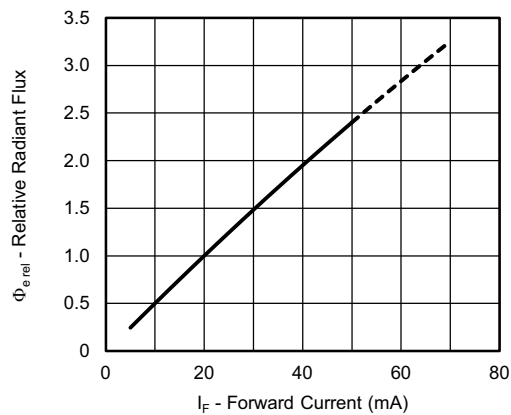

Fig. 2 - Relative Radiant Power vs. Forward Current

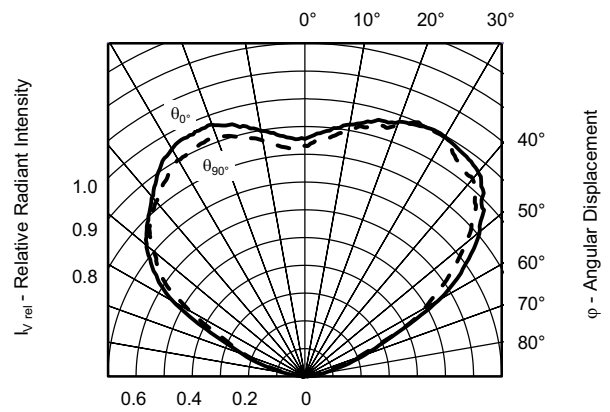

Fig. 5 - Relative Radiant Intensity vs. Angular Displacement

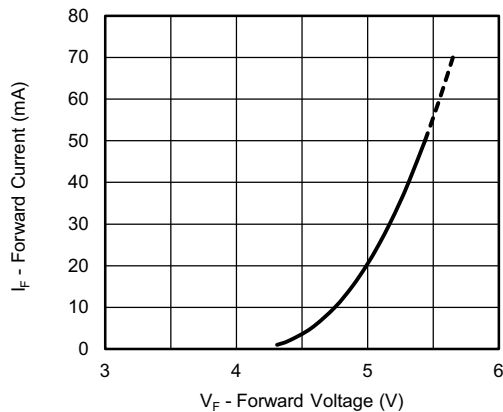

Fig. 3 - Forward Current vs. Forward Voltage

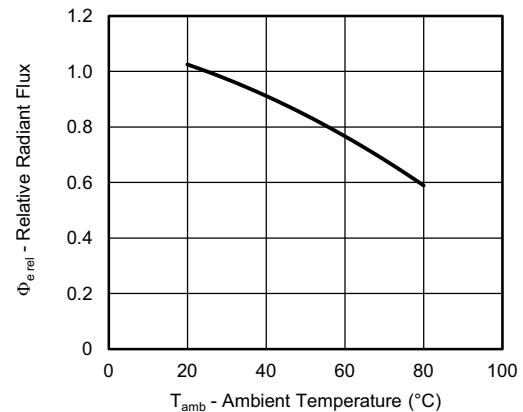
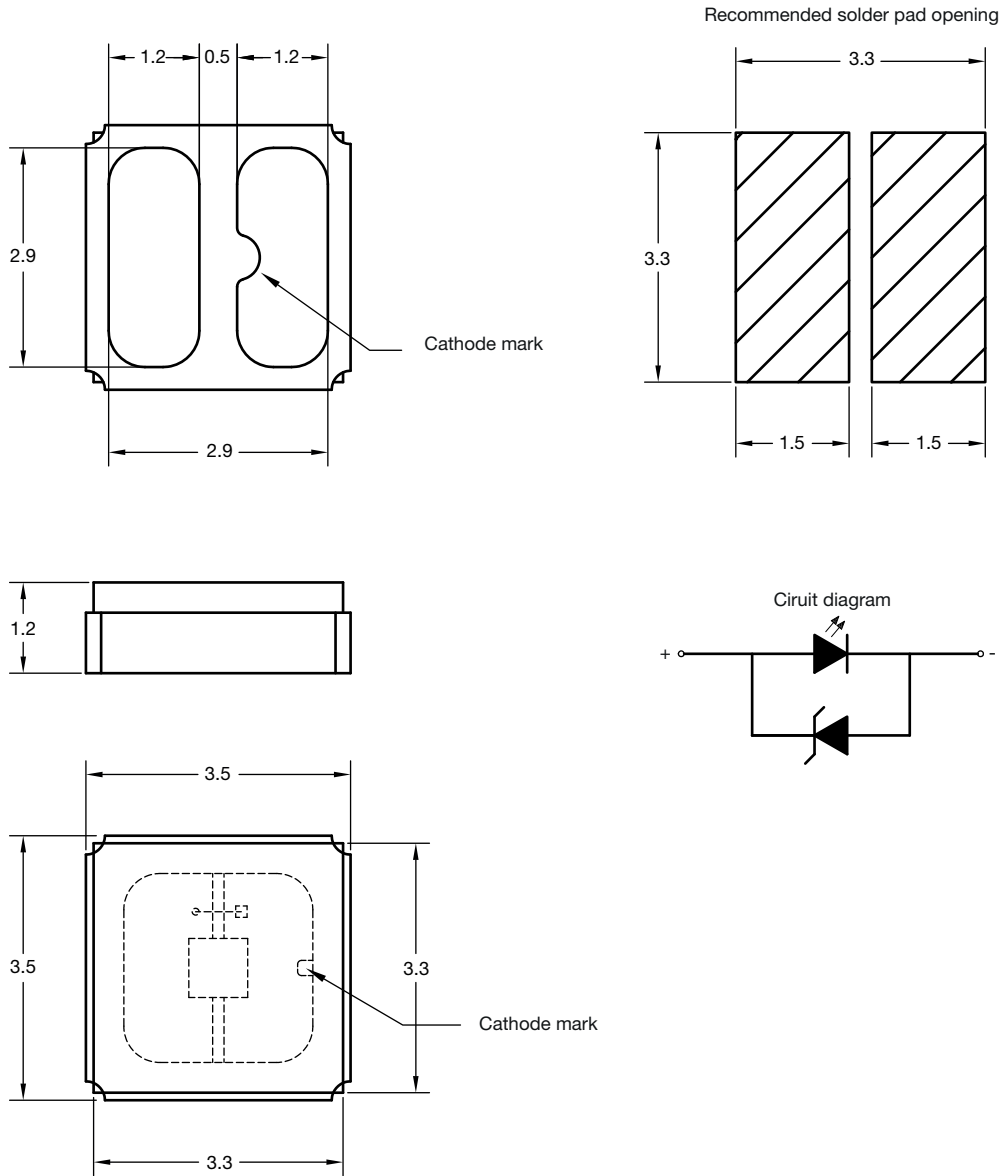

Fig. 6 - Relative Radiant Flux vs. Ambient Temperature



**PACKAGE DIMENSIONS** in millimeters





TAPE AND REEL DIMENSIONS in millimeters

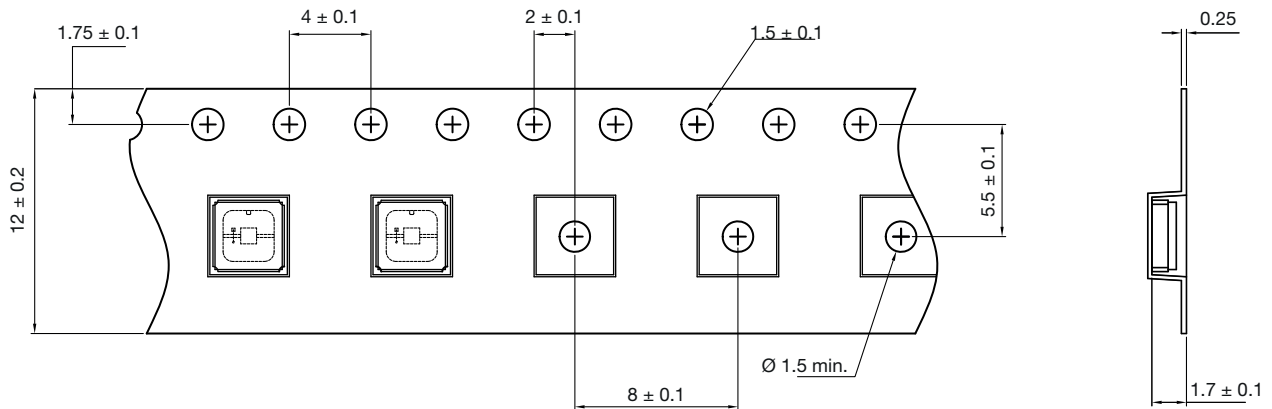
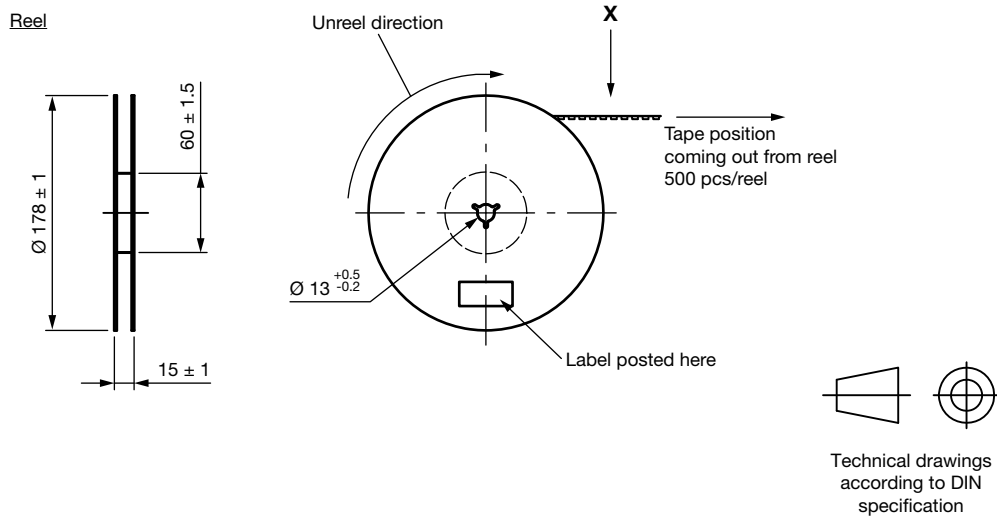

**SOLDERING PROFILE**

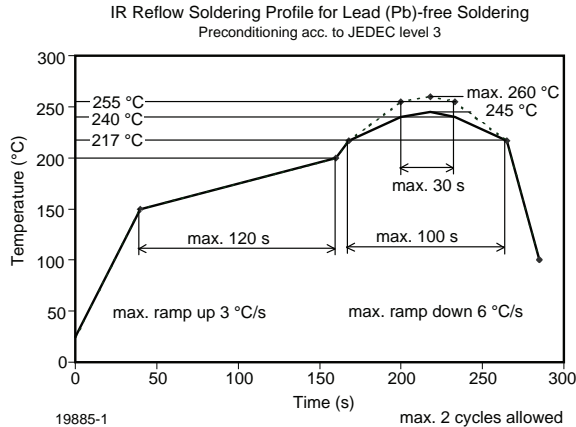
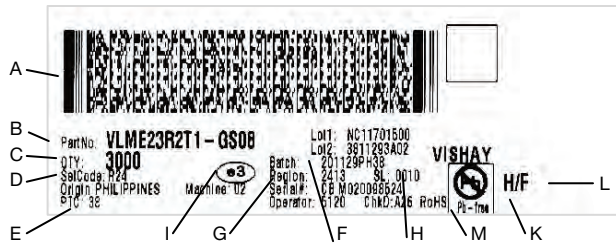

Fig. 7 - Vishay Lead (Pb)-free Reflow Soldering Profile (according to J-STD-020C)

**BAR CODE PRODUCT LABEL (example only)**



- a. 2D barcode
- b. Vishay part number
- c. Quantity
- d. SEL = selection code (binning)
- e. Code of manufacturing plant
- f. Batch = date code: year / week / plant code
- g. Region code
- h. SL = sales location
- i. Terminations finishing
- j. Lead (Pb)-free symbol
- k. Halogen-free symbol
- l. RoHS symbol

**DRY PACKING**

The reel is packed in an anti-humidity bag to protect the devices from absorbing moisture during transportation and storage.

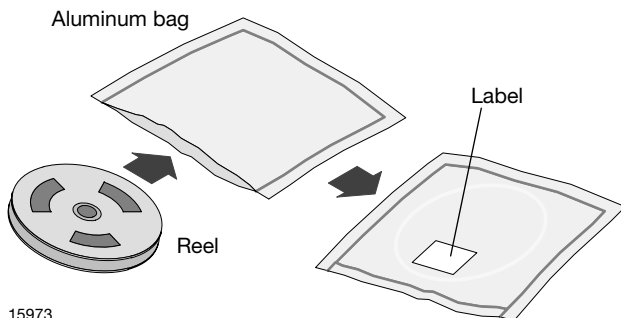

15973

**FINAL PACKING**

The sealed reel is packed into a cardboard box. A secondary cardboard box is used for shipping purposes.

**RECOMMENDED METHOD OF STORAGE**

Dry box storage is recommended as soon as the aluminum bag has been opened to prevent moisture absorption. The following conditions should be observed, if dry boxes are not available:

- Storage temperature 10 °C to 30 °C
- Storage humidity ≤ 60 % RH max.

After more than 168 h under these conditions moisture content will be too high for reflow soldering.

In case of moisture absorption, the devices will recover to the former condition by drying under the following condition:

- 192 h at 40 °C + 5 °C / - 0 °C and < 5 % RH (dry air / nitrogen) or
- 24 h at 60 °C + 5 °C and < 5 % RH for all device containers or
- 24 h at 100 °C + 5 °C not suitable for reel or tubes.

An EIA JEDEC® standard JESD22-A112 level 3 label is included on all dry bags.



17028-2

Example of JESD22-A112 level 3 label

**ESD PRECAUTION**

Proper storage and handling procedures should be followed to prevent ESD damage to the devices especially when they are removed from the antistatic shielding bag. Electrostatic sensitive devices warning labels are on the packaging.

**VISHAY SEMICONDUCTORS STANDARD BAR CODE LABELS**

The Vishay Semiconductors standard bar code labels are printed at final packing areas. The labels are on each packing unit and contain Vishay Semiconductors specific data.



## **Disclaimer**

ALL PRODUCT, PRODUCT SPECIFICATIONS AND DATA ARE SUBJECT TO CHANGE WITHOUT NOTICE TO IMPROVE RELIABILITY, FUNCTION OR DESIGN OR OTHERWISE.

Vishay Intertechnology, Inc., its affiliates, agents, and employees, and all persons acting on its or their behalf (collectively, "Vishay"), disclaim any and all liability for any errors, inaccuracies or incompleteness contained in any datasheet or in any other disclosure relating to any product.

Vishay makes no warranty, representation or guarantee regarding the suitability of the products for any particular purpose or the continuing production of any product. To the maximum extent permitted by applicable law, Vishay disclaims (i) any and all liability arising out of the application or use of any product, (ii) any and all liability, including without limitation special, consequential or incidental damages, and (iii) any and all implied warranties, including warranties of fitness for particular purpose, non-infringement and merchantability.

Statements regarding the suitability of products for certain types of applications are based on Vishay's knowledge of typical requirements that are often placed on Vishay products in generic applications. Such statements are not binding statements about the suitability of products for a particular application. It is the customer's responsibility to validate that a particular product with the properties described in the product specification is suitable for use in a particular application. Parameters provided in datasheets and / or specifications may vary in different applications and performance may vary over time. All operating parameters, including typical parameters, must be validated for each customer application by the customer's technical experts. Product specifications do not expand or otherwise modify Vishay's terms and conditions of purchase, including but not limited to the warranty expressed therein.

Except as expressly indicated in writing, Vishay products are not designed for use in medical, life-saving, or life-sustaining applications or for any other application in which the failure of the Vishay product could result in personal injury or death. Customers using or selling Vishay products not expressly indicated for use in such applications do so at their own risk. Please contact authorized Vishay personnel to obtain written terms and conditions regarding products designed for such applications.

No license, express or implied, by estoppel or otherwise, to any intellectual property rights is granted by this document or by any conduct of Vishay. Product names and markings noted herein may be trademarks of their respective owners.

Компания «Life Electronics» занимается поставками электронных компонентов импортного и отечественного производства от производителей и со складов крупных дистрибьюторов Европы, Америки и Азии.

С конца 2013 года компания активно расширяет линейку поставок компонентов по направлению коаксиальный кабель, кварцевые генераторы и конденсаторы (керамические, пленочные, электролитические), за счёт заключения дистрибьюторских договоров

Мы предлагаем:

- Конкурентоспособные цены и скидки постоянным клиентам.
- Специальные условия для постоянных клиентов.
- Подбор аналогов.
- Поставку компонентов в любых объемах, удовлетворяющих вашим потребностям.
- Приемлемые сроки поставки, возможна ускоренная поставка.
- Доставку товара в любую точку России и стран СНГ.
- Комплексную поставку.
- Работу по проектам и поставку образцов.
- Формирование склада под заказчика.
- Сертификаты соответствия на поставляемую продукцию (по желанию клиента).
- Тестирование поставляемой продукции.
- Поставку компонентов, требующих военную и космическую приемку.
- Входной контроль качества.
- Наличие сертификата ISO.

В составе нашей компании организован Конструкторский отдел, призванный помогать разработчикам, и инженерам.

Конструкторский отдел помогает осуществить:

- Регистрацию проекта у производителя компонентов.
- Техническую поддержку проекта.
- Защиту от снятия компонента с производства.
- Оценку стоимости проекта по компонентам.
- Изготовление тестовой платы монтаж и пусконаладочные работы.



Тел: +7 (812) 336 43 04 (многоканальный)

Email: [org@lifeelectronics.ru](mailto:org@lifeelectronics.ru)