

RF Modulator for VHF Band

DESCRIPTION

The NJM2536A is a RF modulator IC especially designed for VHF band RF modulator and consists of video clamp circuit, white clip circuit, video AM modulator and audio FM modulator, built into one chip.

PACKAGE OUTLINE

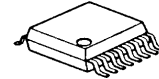

NJM2536AV

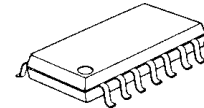

NJM2536AM

FEATURES

- Operating Voltage 5V
- Picture-to-sound ratio is adjustable
- VHF Oscillator on chip
- Carrier-off switch function on chip
- Regulator on chip
- Bipolar Technology
- Package Outline:DMP/SSOP14

BLOCK DIAGRAM

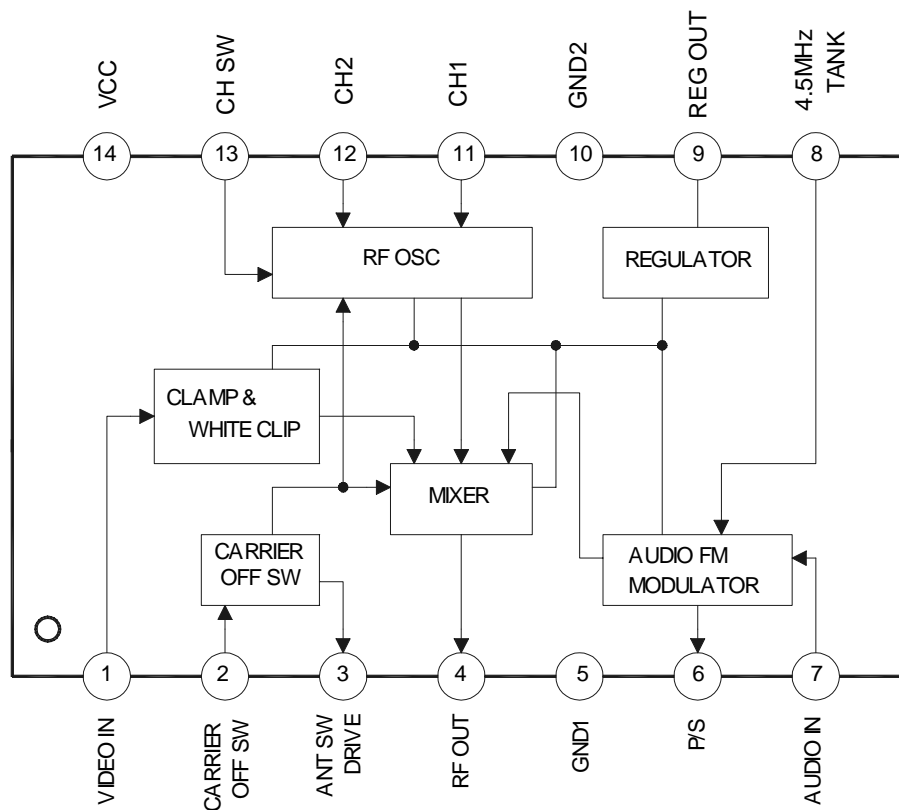

NJM2536A

■ ABSOLUTE MAXIMUM RATINGS

($T_A=25^\circ\text{C}$)

Parameter	Symbol	Ratings	Unit
Supply Voltage	V_{CC}	7	V
Power Dissipation	P_D	300	mW
Input Voltage	V_I	-0.3 to V_{CC}	V
Operating Temperature Range	T_{opr}	-20 to +75	$^\circ\text{C}$
Storage Temperature Range	T_{stg}	-40 to +125	$^\circ\text{C}$

■ RECOMMENDED OPERATING VOLTAGE RANGE

($T_A=25^\circ\text{C}$)

Parameter	Condition	Symbol	Min.	Typ.	Max.	Unit
Operating Voltage		V_{CC}	4.5	5.0	5.5	V

■ ELECTRICAL CHARACTERISTICS

($V_{CC}=5\text{V}, T_A=25^\circ\text{C}$)

Parameter	Condition	Symbol	Min.	Typ.	Max.	Unit
Operating Current	No video/audio input signal, CARRIER OFF SW(Pin2)=5V	I_{CC}	13.5	16.0	22.5	mA
ANT SW DRIVE Output Voltage -1	CARRIER OFF SW(Pin2)=5V $I_D=26\text{mA}$	V_{ANT1}	3.7	4.0	4.3	V
ANT SW DRIVE Output Voltage -2	CARRIER OFF SW(Pin2)=Open $V_{CC}=2\text{V}$	V_{ANT2}	0	0.065	0.1	V
Video Output Level (Note 1)	Video input signal(Pin1)= $0.5V_{PP}$	V_O	(83)	86	(89)	dBu
Video Modulation Depth (Note 1)	Video input signal(Pin1)= $0.5V_{PP}$	mp	(70)	76	(82)	%
Video Limiter Modulation Depth (Note 1)	Video input signal(Pin1)= $1.0V_{PP}$	mpmax	(85)	94	(98)	%
Differential Gain	Video input signal(Pin1)= $0.5V_{PP}$ Staircase	DG	-	± 3	-	%
Differential Phase	Video input signal(Pin1)= $0.5V_{PP}$ Staircase	DP	-	± 3	-	deg
Picture-to-sound Ratio (Note 1)	Video input signal(Pin1)= $0.5V_{PP}$	PS	(11)	13	(15)	dB
Sound FM Modulation Sensitivity	Deviation of fs per 100mV	β_b	-	0.51	-	KHz/mV
Audio Distortion	Audio input signal(Pin7)= $0.05V_{PP}$ 1kHz sine wave	THD	-	0.3	-	%
Audio Signal-to-noise Ratio	Sound Modulation 60% 1kHz sine wave	ASN	-	60	-	dB
Maximum Sound FM Modulation	Audio input signal(Pin7)= $1.0V_{PP}$ 1kHz sine wave	msmax	-	700	-	%

(Note 1) Because AC characteristics largely depends on application circuit, these parameters are specified by the DC characteristics as shown in next page.

■ **DC ELECTRICAL CHARACTERISTICS** ($V_{CC}=5V, Pin2=2.5V, T_A=25^{\circ}C$, otherwise noted. All measurements performed in the DC test circuit are shown in next page)

Parameter	Condition (Note 2)	Symbol	Min.	Typ.	Max.	Unit
Video Output Signal Amplitude 1	$Gw1=Gwh1-Gwl1$	Gw1	62.4	85	124.5	mV
Video Output Signal Amplitude 2	$Gw2=Gwh2-Gwl2$	Gw2	62.4	85	124.5	mV
Video Modulation Depth	$Mp=((Gw1-Mw)/Gw1) \times 100$ where $Mw=Mwh-Mwl$	Mp	70	76	82	%
Video Limiter Modulation Depth (Note 2)	$Mpmax=((Gw1-Wc)/Gw1) \times 100$ where $Wc=Wch-Wcl$	Mpmax	85	94	98	%
Picture-to-sound Ratio	$Ps=Psh-Psl$	Ps	-70	-45	-35.1	mV

(Note 2) Explanation of symbols

- V_v : VIDEO IN output voltage at Pin1
- V_{11h} : CH1 output voltage at Pin11
CH SW (Pin13) input = 2.5V
- V_{12h} : CH1 output voltage at pin12
CH SW (Pin13) input = 0.5V
- $Gwh1$: RF OUT output voltage at Pin4
VIDEO IN (Pin 1) input = V_v , CH1 (Pin11) = $V_{11h} + 0.15V$, CH SW (Pin13) input = 2.5V
- $Gwl1$: RF OUT output voltage at Pin4
VIDEO IN (Pin 1) input = V_v , CH1 (Pin11) = $V_{11h} - 0.15V$, CH SW (Pin13) input = 2.5V
- $Gwh2$: RF OUT output voltage at Pin4
VIDEO IN (Pin 1) input = V_v , CH2 (Pin12) = $V_{12h} + 0.15V$, CH SW (Pin13) input = 0.5V
- $Gwl2$: RF OUT output voltage at Pin4
VIDEO IN (Pin 1) input = V_v , CH2 (Pin12) = $V_{12h} - 0.15V$, CH SW (Pin13) input = 0.5V
- Mwh : RF OUT output voltage at Pin4
VIDEO IN (Pin 1) input = $V_v + 0.43V$, CH1 (Pin11) = $V_{11h} + 0.15V$, CH SW (Pin13) input = 2.5V
- Mwl : RF OUT output voltage at Pin4
VIDEO IN (Pin 1) input = $V_v + 0.43V$, CH1 (Pin11) = $V_{11h} - 0.15V$, CH SW (Pin13) input = 2.5V
- Wch : RF OUT output voltage at Pin4
VIDEO IN (Pin 1) input = $V_v + 0.8V$, CH1 (Pin11) = $V_{11h} + 0.15V$, CH SW (Pin13) input = 2.5V
- Wcl : RF OUT output voltage at Pin4
VIDEO IN (Pin 1) input = $V_v + 0.8V$, CH1 (Pin11) = $V_{11h} - 0.15V$, CH SW (Pin13) input = 2.5V
- V_{Ps} : P/S output voltage at Pin6
CARRIER OFF SW (Pin 2) input = 2.5V
- Psh : RF OUT output voltage at Pin4
P/S (Pin 6) input = $V_{Ps} + 0.2V$, CH1 (Pin11) = 2.4V, CH SW (Pin13) input = 2.5V
- Psl : RF OUT output voltage at Pin4
P/S (Pin 6) input = $V_{Ps} - 0.2V$, CH1 (Pin11) = 2.4V, CH SW (Pin13) input = 2.5V

NJM2536A

■ AC TEST CIRCUIT

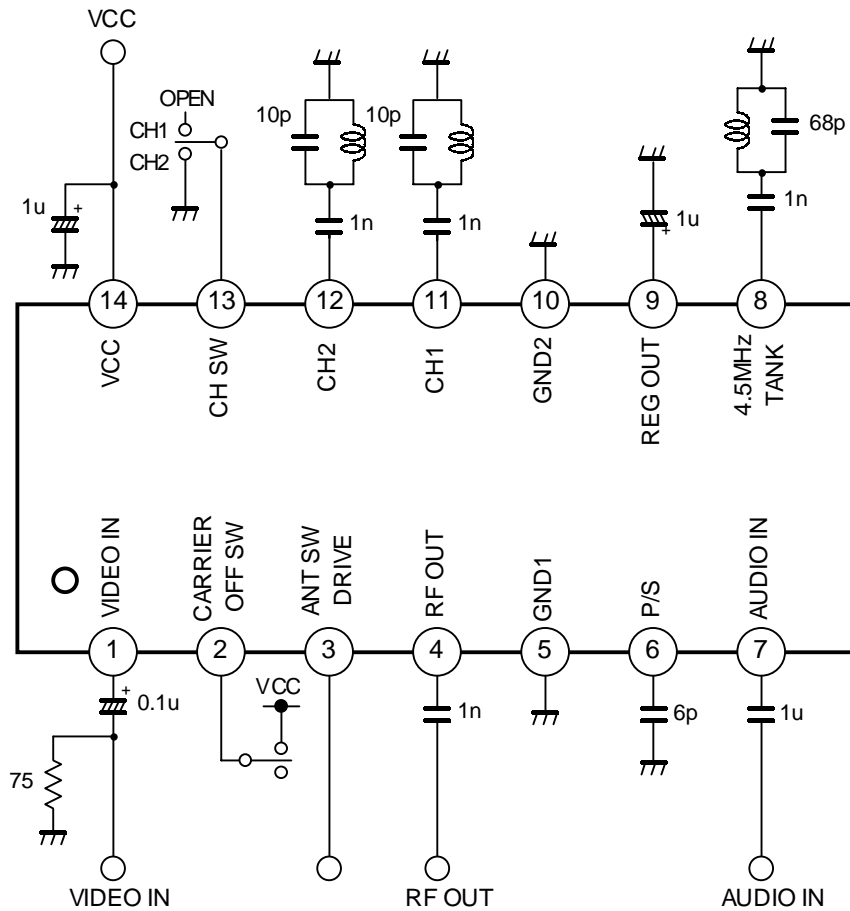

■ DC TEST CIRCUIT

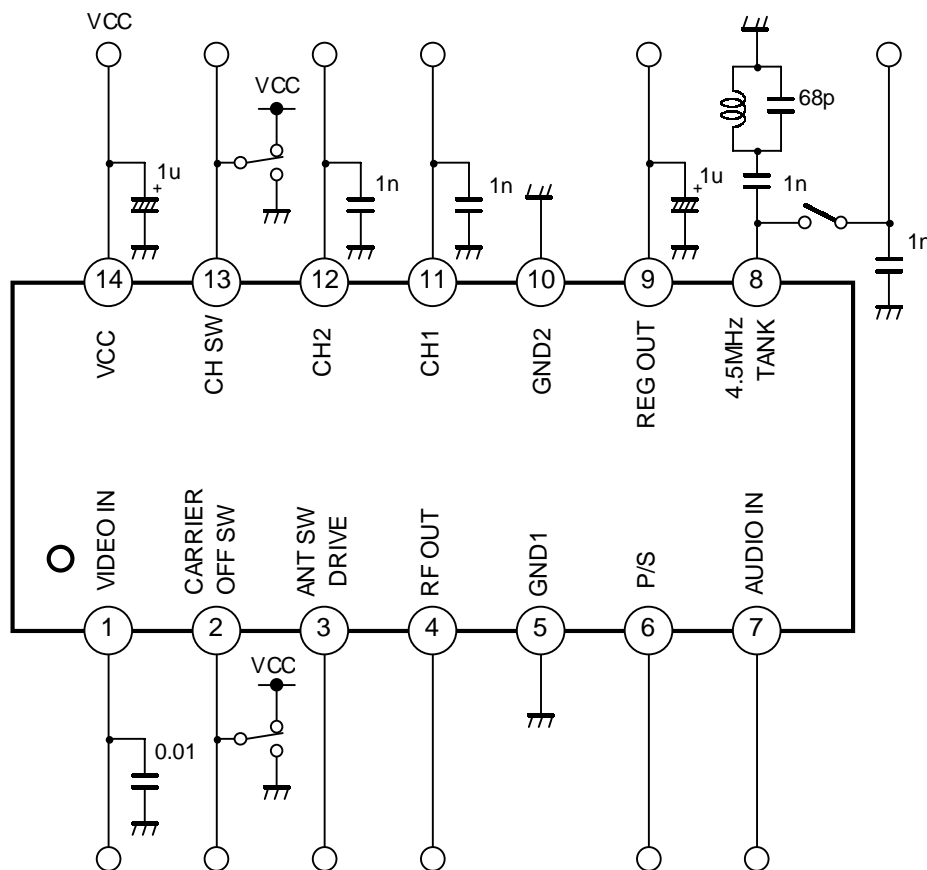

■ TERMINAL CHARACTERISTICS

No.	Symbol	Typ. DC Voltage (V)	Equivalent Circuit	Function
1	VIDEO IN	1.9		Video Signal Input
2	CARRIER OFF SW	-		Picture Carrier-Off Switch
3	ANT SW DRIVE	4 (Pin2=High) 0 (Pin2=Low)		ANT Switch Drive Voltage Output
4	RF OUT	4		RF Signal Output
5	GND1	0		GND terminal except for oscillator circuit
6	P/S	2.8		Picture-to-sound Ratio Adjust

NJM2536A

No.	Symbol	Typ. DC Voltage (V)	Equivalent Circuit	Function
7	AUDIO IN	0.035		Audio Signal Input
8	4.5MHz TANK	2.9		4.5MHz Tank Coil for Sound FM Modulation Circuit
9	REG OUT	4		Regulator Output
10	GND2	0		GND for Oscillator Circuit
11	CH1	2.24 (OSC:ON) 2.30 (OSC:OFF)		RF Oscillator Pin (Base)
12	CH2	2.24 (OSC:ON) 2.30 (OSC:OFF)		RF Oscillator Pin (Base)

No.	Symbol	Typ. DC Voltage (V)	Equivalent Circuit	Function
13	CH SW	2.38		Output channel Select Switch
14	VCC	5		Power Supply

■ TYPICAL CHARACTERISTICS

$T_A=25^\circ\text{C}$

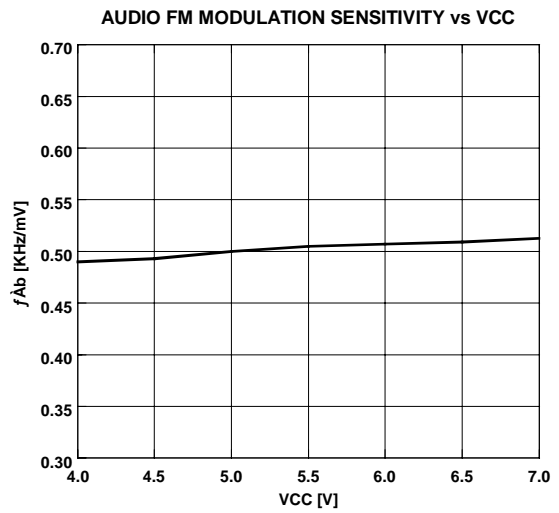
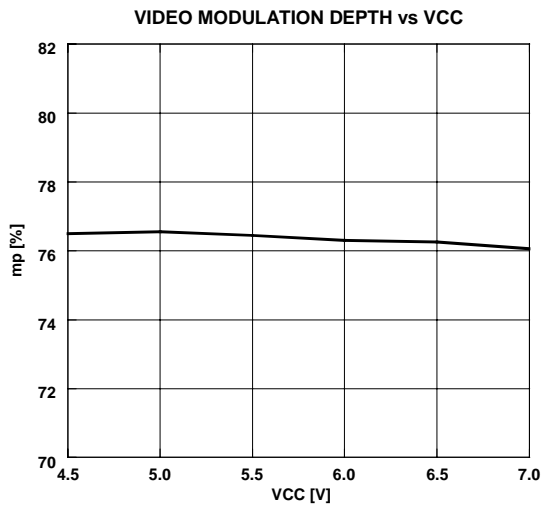
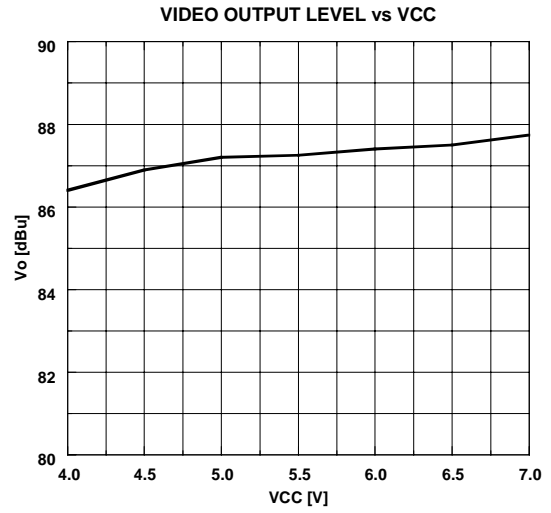
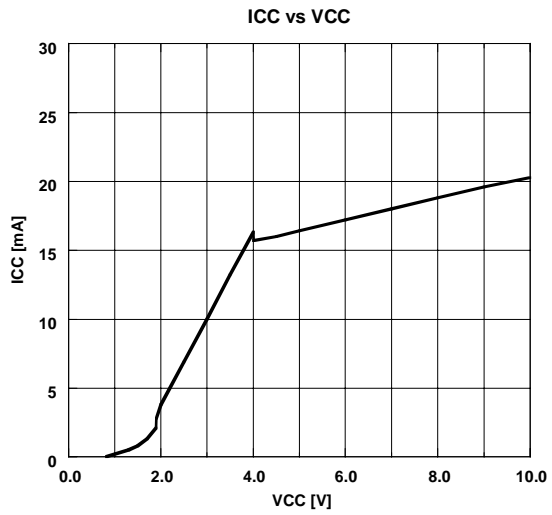

MEMO

[CAUTION]

The specifications on this databook are only given for information, without any guarantee as regards either mistakes or omissions. The application circuits in this databook are described only to show representative usages of the product and not intended for the guarantee or permission of any right including the industrial rights.

Компания «Life Electronics» занимается поставками электронных компонентов импортного и отечественного производства от производителей и со складов крупных дистрибьюторов Европы, Америки и Азии.

С конца 2013 года компания активно расширяет линейку поставок компонентов по направлению коаксиальный кабель, кварцевые генераторы и конденсаторы (керамические, пленочные, электролитические), за счёт заключения дистрибьюторских договоров

Мы предлагаем:

- Конкурентоспособные цены и скидки постоянным клиентам.
- Специальные условия для постоянных клиентов.
- Подбор аналогов.
- Поставку компонентов в любых объемах, удовлетворяющих вашим потребностям.
- Приемлемые сроки поставки, возможна ускоренная поставка.
- Доставку товара в любую точку России и стран СНГ.
- Комплексную поставку.
- Работу по проектам и поставку образцов.
- Формирование склада под заказчика.
- Сертификаты соответствия на поставляемую продукцию (по желанию клиента).
- Тестирование поставляемой продукции.
- Поставку компонентов, требующих военную и космическую приемку.
- Входной контроль качества.
- Наличие сертификата ISO.

В составе нашей компании организован Конструкторский отдел, призванный помогать разработчикам, и инженерам.

Конструкторский отдел помогает осуществить:

- Регистрацию проекта у производителя компонентов.
- Техническую поддержку проекта.
- Защиту от снятия компонента с производства.
- Оценку стоимости проекта по компонентам.
- Изготовление тестовой платы монтаж и пусконаладочные работы.



Тел: +7 (812) 336 43 04 (многоканальный)

Email: org@lifeelectronics.ru