

Repeater power supply - MACX MCR-SL-RPSSI-I-UP-SP - 2924210

Please be informed that the data shown in this PDF Document is generated from our Online Catalog. Please find the complete data in the user's documentation. Our General Terms of Use for Downloads are valid (<http://phoenixcontact.com/download>)



Repeater power supply for supplying 2 and 3-conductor transmitters with HART transmission and wide range power supply, SIL, spring-cage connection

Product Features

- ✓ 250 Ω resistor that can be activated via DIP switches to increase HART impedance for low-resistance systems
- ✓ Up to SIL 2 according to EN 61508
- ✓ Installation in zone 2, protection type "n" (EN 60079-15) permitted
- ✓ Bidirectional transmission of digital HART communication signals
- ✓ Plug-in screw or spring-cage connection technology (Push-in technology), with integrated sockets for HART communicators
- ✓ Wide-range power supply of 19.2 ... 253 V AC/DC
- ✓ 3-way electrical isolation
- ✓ 0/4 ... 20 mA output (active or passive), 0/1 ... 5 V, can be selected via DIP switches
- ✓ 0/4 ... 20 mA input (powered or not powered)



Key commercial data

Packing unit	1 pc
Weight per Piece (excluding packing)	140.0 GRM
Custom tariff number	85437090
Country of origin	Germany

Technical data

Note

Utilization restriction	EMC: class A product, see manufacturer's declaration in the download area
-------------------------	---

Dimensions

Repeater power supply - MACX MCR-SL-RPSSI-I-UP-SP - 2924210

Technical data

Dimensions

Width	17.5 mm
Height	99 mm
Depth	114.5 mm

Ambient conditions

Ambient temperature (operation)	-20 °C ... 60 °C (Any mounting position)
Ambient temperature (storage/transport)	-40 °C ... 80 °C
Maximum altitude	≤ 2000 m
Permissible humidity (operation)	10 % ... 95 % (non-condensing)
Degree of protection	IP20

Input data

Current input signal	0 mA ... 20 mA
	4 mA ... 20 mA
Transmitter supply voltage	> 16 V (at 20 mA)
Voltage drop	< 3.5 V (in input isolating amplifier operation)

Output data

Signal output	Current output
Voltage output signal	0 V ... 5 V (internal resistance, 250 Ω, 0.1%)
Current output signal	0 mA ... 20 mA (active)
	4 mA ... 20 mA (active)
	0 mA ... 20 mA (14 ... 26 V ext. source voltage)
	4 mA ... 20 mA (14 ... 26 V ext. source voltage)
Transmission Behavior	1:1 to input signal
Load/output load current output	< 600 Ω (I output)
Output ripple	< 20 mV _{rms}

Power supply

Supply voltage range	24 V ... 230 V AC/DC (-20%/+10%, 50/60 Hz)
Max. current consumption	< 75 mA (at 24 V DC)
Power consumption	< 1.8 W

Connection data

Conductor cross section solid min.	0.2 mm ²
Conductor cross section solid max.	1.5 mm ²
Conductor cross section stranded min.	0.2 mm ²
Conductor cross section stranded max.	1.5 mm ²
Conductor cross section AWG/kcmil min.	24
Conductor cross section AWG/kcmil max.	16

Repeater power supply - MACX MCR-SL-RPSSI-I-UP-SP - 2924210

Technical data

Connection data

Stripping length	8 mm
Connection method	Spring-cage connection

General

No. of channels	1
Maximum transmission error	< 0.1 % (of final value)
Transmission error, typical	< 0.05 % (of final value)
Maximum temperature coefficient	< 0.01 %/K
Step response (10-90%)	< 600 µs (for 4 mA ... 20 mA step)
Status display	Green LED (supply voltage)
Inflammability class according to UL 94	V0
Pollution degree	2
Surge voltage category	II
Housing material	PA 66-FR
Color	green
Designation	Input/output/power supply
Electrical isolation	300 V _{rms} (Rated insulation voltage (surge voltage category II; pollution degree 2, safe isolation as per EN 61010-1))
	2.5 kV (50 Hz, 1 min., test voltage)
Conformance	CE-compliant, additionally EN 61326
ATEX	# II 3 G Ex nA IIC T4 Gc X
UL, USA / Canada	UL applied for
Functional Safety (SIL)	SIL 2 according to EN 61508

Data communication (bypass)

HART function	Yes
Protocols supported	HART

Classifications

eCl@ss

eCl@ss 4.0	27210120
eCl@ss 4.1	27210120
eCl@ss 5.0	27210120
eCl@ss 5.1	27210120
eCl@ss 6.0	27210120
eCl@ss 7.0	27210120
eCl@ss 8.0	27210120

Repeater power supply - MACX MCR-SL-RPSSI-I-UP-SP - 2924210

Classifications

ETIM

ETIM 2.0	EC001485
ETIM 3.0	EC001485
ETIM 4.0	EC001485
ETIM 5.0	EC002653

UNSPSC

UNSPSC 6.01	30211506
UNSPSC 7.0901	39121008
UNSPSC 11	39121008
UNSPSC 12.01	39121008
UNSPSC 13.2	39121008

Approvals

Approvals

Approvals

Functional Safety

Ex Approvals

ATEX

Approvals submitted

Approval details

Functional Safety

Drawings

Repeater power supply - MACX MCR-SL-RPSSI-I-UP-SP - 2924210

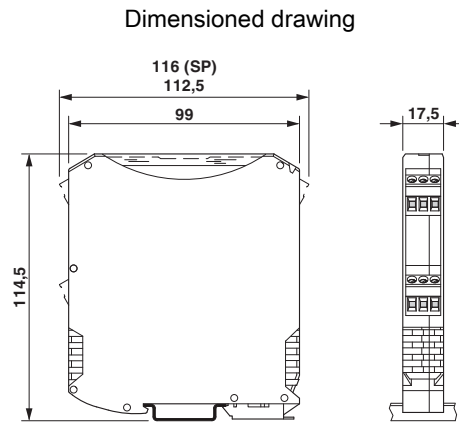
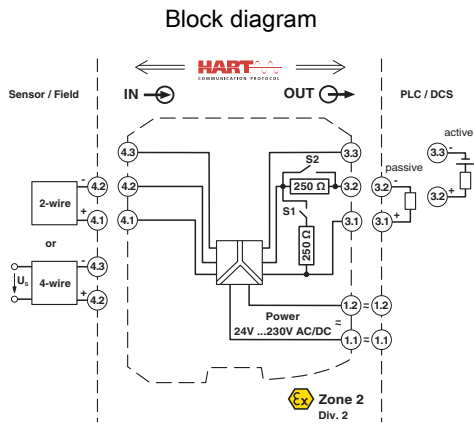

Connection example

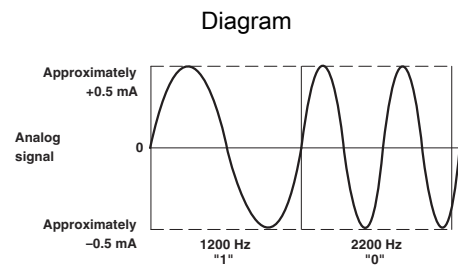
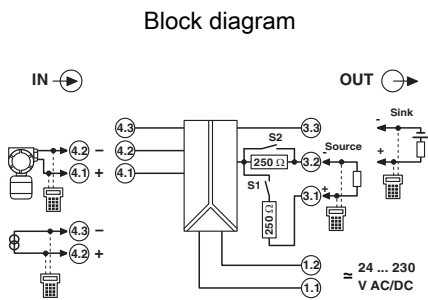

Signal transmission analog and digital at the same time

Компания «Life Electronics» занимается поставками электронных компонентов импортного и отечественного производства от производителей и со складов крупных дистрибьюторов Европы, Америки и Азии.

С конца 2013 года компания активно расширяет линейку поставок компонентов по направлению коаксиальный кабель, кварцевые генераторы и конденсаторы (керамические, пленочные, электролитические), за счёт заключения дистрибьюторских договоров

Мы предлагаем:

- Конкурентоспособные цены и скидки постоянным клиентам.
- Специальные условия для постоянных клиентов.
- Подбор аналогов.
- Поставку компонентов в любых объемах, удовлетворяющих вашим потребностям.
- Приемлемые сроки поставки, возможна ускоренная поставка.
- Доставку товара в любую точку России и стран СНГ.
- Комплексную поставку.
- Работу по проектам и поставку образцов.
- Формирование склада под заказчика.
- Сертификаты соответствия на поставляемую продукцию (по желанию клиента).
- Тестирование поставляемой продукции.
- Поставку компонентов, требующих военную и космическую приемку.
- Входной контроль качества.
- Наличие сертификата ISO.

В составе нашей компании организован Конструкторский отдел, призванный помогать разработчикам, и инженерам.

Конструкторский отдел помогает осуществить:

- Регистрацию проекта у производителя компонентов.
- Техническую поддержку проекта.
- Защиту от снятия компонента с производства.
- Оценку стоимости проекта по компонентам.
- Изготовление тестовой платы монтаж и пусконаладочные работы.



Тел: +7 (812) 336 43 04 (многоканальный)

Email: org@lifeelectronics.ru