

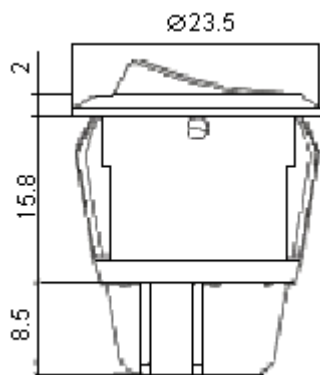

Ø 20.2

3mm Maximum



20 A 12 V dc

Dimensions : Millimetres

Scope

These requirements cover manually and mechanically operable special-use switches:

That is for use on direct current as well as on alternating current only

For which the load ratings do not exceed 60 amperes at 250 volts or a lower potential and 30 amperes or 2 horsepower at 600 volts or a lower potential

Electrical Ratings

Item	Requirements
Rated voltage and current	(base on switch type)
Contact resistance (new state)	<100 mΩ (5 V, 1 A dc)
Dielectric strength (new state)	>1,000 V >2,500 V (10 mA between the contacts)
Insulation resistance (new state)	>100 MΩ (500 V dc between the open contacts)
Inrush current	50 A / 3 msec (capacitive load)
Electrical life endurance	>6,000 operations Volt drop : <100 mV >10,000 operations
Temperature rise at the terminals (according to electrical life endurance)	<30°C - 6,000 operations <45°C - 10,000 operations (ambient conditions : 25 ±2°C and 65 ±5% RH)

Mechanical Characteristics

Item	Requirements
Actuating force	(base on switch type)
Operating life endurance	>100,000 operations
Terminal strength	>2.5 kg - solder terminal >6.8 kg - plug-in / screw terminal
Solderability of terminals	Maximum 350°C / 3 s (no pressure may be exerted on the terminals when soldering by hand)

Environmental

Item	Requirements
Ambient temperature	-20°C to +65°C
Humidity	Maximum 85%
Salt spray test	No remarkable rust in metal parts (5% Salt / 35°C / 24 hours)
Shock test	No mechanical defect or damage (100 g / 10 ms / X, Y, Z 3 times)
Vibration test	No mechanical defect damage (10 to 55 Hz / 1.5 mm / X, Y, Z 2 hours)

Part Number Table

Description	Part Number
SWITCH, ROCKER, SPST, ON-OFF	R13-112A-02-BB-0A
SWITCH, ROCKER, SPST, ON-OFF, MOM	R13-112F-02-BB-0A
SWITCH, ROCKER, SPST, ON-OFF	R13-112A5-02-WW-0A
SWITCH, ROCKER, SPST, ON-OFF	R13-112A-02-BB-3A
SWITCH, ROCKER, SPST, ON-OFF, MOM	R13-112F-02-BB-3A
SWITCH, ROCKER, SPST, ON-OFF	R13-112A5-02-WW-3A
SWITCH, ROCKER, DPST, ON-OFF	R13-244A-02-BB-0A
SWITCH, ROCKER, DPST, ON-OFF	R13-244A5-02-WW-0A
SWITCH, ROCKER, DPST, ON-OFF	R13-244A-02-BB-3A
SWITCH, ROCKER, DPST, ON-OFF	R13-244A5-02-WW-3A
SWITCH, ROCKER, SPST, ON-OFF, IP65	R13-112A8-02-BB-0A
SWITCH, ROCKER, SPST, IP65, MOM	R13-112F8-02-BB-0A
SWITCH, ROCKER, SPST, ON-OFF, IP65	R13-112A8-02-BB-2A

Rocker Switches

Part Number Table

Description	Part Number
SWITCH, ROCKER, SPST, IP65, MOM	R13-112F8-02-BB-2A
SWITCH, ROCKER, SPST, RED ILLUM.	R13-112B-02-BR-0A
SWITCH, ROCKER, SPST, GREEN ILLUM.	R13-112B-02-BG-0A
SWITCH, ROCKER, DPST, RED ILLUM.	R13-244B-02-BR-0A
SWITCH, ROCKER, DPST, GREEN ILLUM.	R13-244B-02-BG-0A
SWITCH, ROCKER, SPST, RED, IP65	R13-112B8W-02-BR-0A
SWITCH, ROCKER, SPST, GREEN, IP65	R13-112B8W-02-BG-0A
SWITCH, ROCKER, SPST, RED ILLUM.	R13-112B9-02-BBR-0A
SWITCH, ROCKER, SPST, GREEN ILLUM.	R13-112B9-02-BBG-0A

Part Number Explanation:

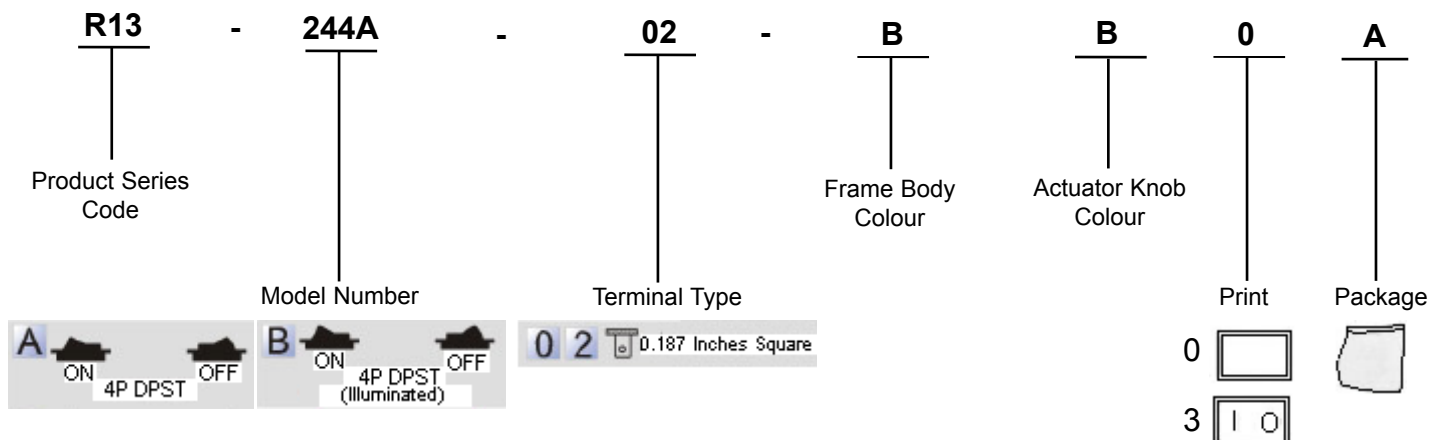

- Frame Body Colour** : B = Black and W = White
Actuator Knob Colour : W = White, B = Black, R = Red and G = Green
Print : 0 = None
Package : A = Bulk

Disclaimer This data sheet and its contents (the "Information") belong to the Premier Farnell Group (the "Group") or are licensed to it. No licence is granted for the use of it other than for information purposes in connection with the products to which it relates. No licence of any intellectual property rights is granted. The Information is subject to change without notice and replaces all data sheets previously supplied. The Information supplied is believed to be accurate but the Group assumes no responsibility for its accuracy or completeness, any error in or omission from it or for any use made of it. Users of this data sheet should check for themselves the Information and the suitability of the products for their purpose and not make any assumptions based on information included or omitted. Liability for loss or damage resulting from any reliance on the Information or use of it (including liability resulting from negligence or where the Group was aware of the possibility of such loss or damage arising) is excluded. This will not operate to limit or restrict the Group's liability for death or personal injury resulting from its negligence. Multicomp is the registered trademark of the Group. © Premier Farnell plc 2012.

Компания «Life Electronics» занимается поставками электронных компонентов импортного и отечественного производства от производителей и со складов крупных дистрибьюторов Европы, Америки и Азии.

С конца 2013 года компания активно расширяет линейку поставок компонентов по направлению коаксиальный кабель, кварцевые генераторы и конденсаторы (керамические, пленочные, электролитические), за счёт заключения дистрибьюторских договоров

Мы предлагаем:

- Конкурентоспособные цены и скидки постоянным клиентам.
- Специальные условия для постоянных клиентов.
- Подбор аналогов.
- Поставку компонентов в любых объемах, удовлетворяющих вашим потребностям.
- Приемлемые сроки поставки, возможна ускоренная поставка.
- Доставку товара в любую точку России и стран СНГ.
- Комплексную поставку.
- Работу по проектам и поставку образцов.
- Формирование склада под заказчика.
- Сертификаты соответствия на поставляемую продукцию (по желанию клиента).
- Тестирование поставляемой продукции.
- Поставку компонентов, требующих военную и космическую приемку.
- Входной контроль качества.
- Наличие сертификата ISO.

В составе нашей компании организован Конструкторский отдел, призванный помогать разработчикам, и инженерам.

Конструкторский отдел помогает осуществить:

- Регистрацию проекта у производителя компонентов.
- Техническую поддержку проекта.
- Защиту от снятия компонента с производства.
- Оценку стоимости проекта по компонентам.
- Изготовление тестовой платы монтаж и пусконаладочные работы.



Тел: +7 (812) 336 43 04 (многоканальный)

Email: org@lifeelectronics.ru