



austriamicrosystems AG

is now

ams AG

The technical content of this austriamicrosystems document is still valid.

Contact information:

Headquarters:

ams AG

Tobelbaderstrasse 30

8141 Unterpremstaetten, Austria

Tel: +43 (0) 3136 500 0

e-Mail: ams_sales@ams.com

Please visit our website at www.ams.com

White Goods Demo Board Manual

AS1115

64 LEDs, I²C Interfaced LED Driver with Keyscan

www.austriamicrosystems.com/AS1115

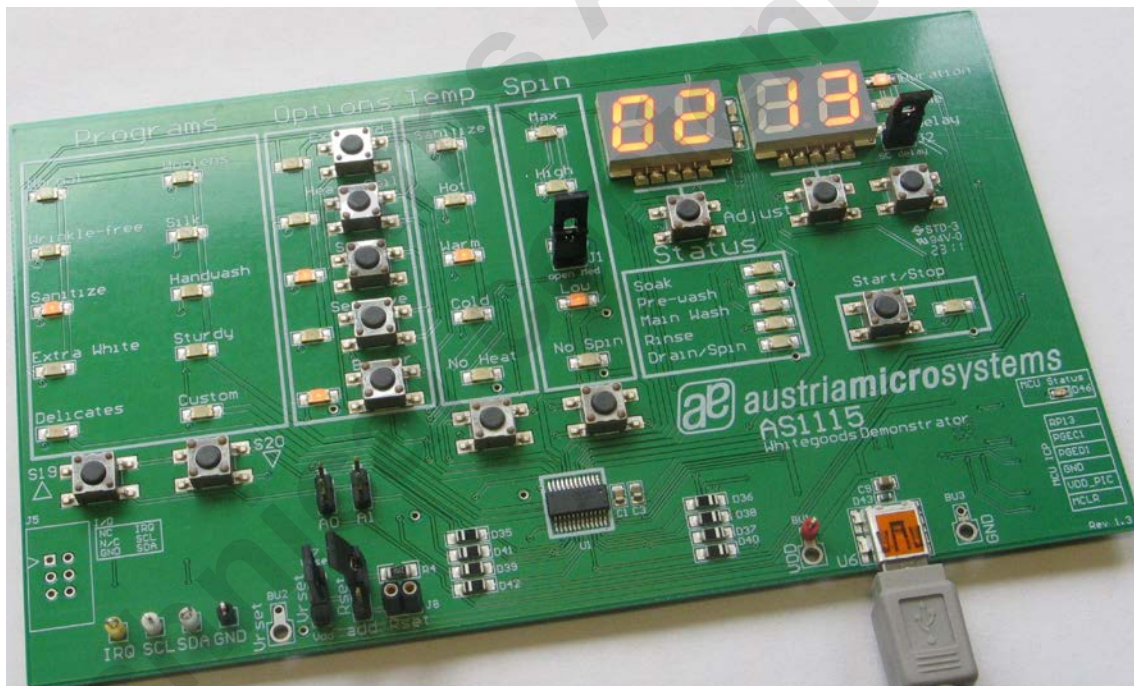

General Description

Board Description

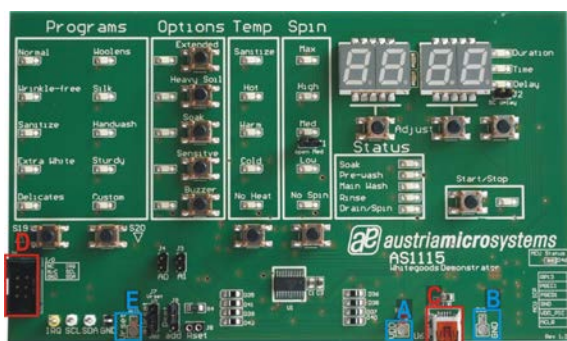

Figure 1: Board Description – Connectors

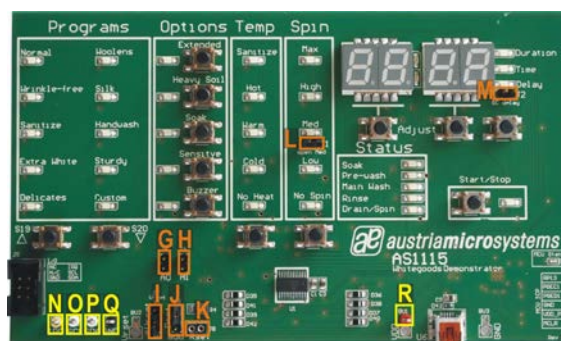

Figure 2: Board Description – Jumper and Measurement Points

Connector Description

Label	Name	Description	Info
A	VDD	Power Supply Connectors for VDD and Ground.	+2.7V to +5.5V
B	GND		
C	USB	Mini USB 5-pin Connector	Supplies the AS1115 with 5V. Connect to a standard USB port. This Connector is <u>also</u> used for data transfer.
D *	I / O	Interface Connector	For a detailed Connector Description see table below.
E	VRSET	Reference Voltage Connector	The brightness of the display segments could be controlled via this connector.

* optional, n.c.





Note: Use only the Connectors VDD “A” and GND “B” or USB Connector “C”. Never use both supply possibilities at the same time!

I/O - Interface Connector “D” Description (optional, n.c.)

	Label	Name	AS1115
	A1	VDD+	Pin 19
	A2	N/C	
	A3	GND	Pin 6
	B1	IRQ	Pin 24
	B2	SCL	Pin 14
	B3	SDA	Pin 1

Jumper Description

Label	Name	Description	Info	
G	A0	Self Addressing Bit 0		Address Bit 0: logic “0”
				Address Bit 0: logic “1”
H	A1	Self Addressing Bit 1		Address Bit 1: logic “0”
				Address Bit 1: logic “1”

I	VRSET	Reference Voltage Jumper		IN: Rset connected to Reference Voltage Connector “E” VDD: Rset connected to VDD
J	RSET	Resistor Selection Jumper		SMD: Rset used is R4 (20kΩ) add RSET: Rset used is “K” (User Resistor)
K	RSET	User Resistor		Connector for User Resistor
L	OPEN	Open Circuit		Remove Jumper to simulate an open circuit.
M	SC	Short Circuit		Set Jumper to simulate a short circuit.

Measurement Points Description

Label	Name	Description	Info
N	IRQ	Interrupt Request	Measurement Points
O	SCL	Serial Clock Input	
P	SDA	Serial Data I/O	
Q	GND	Ground	
R	VDD	Power Supply	

Software

To run the AS1115 a controller is required. A microcontroller is mounted on the bottom side of the PCB to run the white good demoboard. The AS1115 WGB is controlled via the software in combination with the microcontroller. The board is only working in connection with software (GUI). The condition of the LED's (ON or OFF) or the different buttons can be triggered via the software or directly on the board.

Alternatively an external controller can be connected to the demoboard via the I/O Connector “D”.

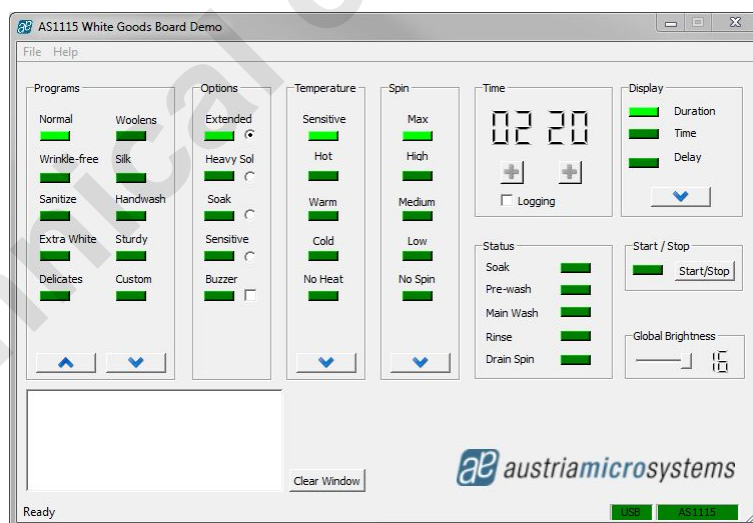

Figure 3: Software Panel

Note:

As a first step make sure that the hardware connection between the PC and the Demoboard via a USB cable is set. The USB cable is for Power supply and for the data connection. After that, start the Software on you PC.

To check if the connection between the Software and the Demoboard is set, the USB and AS1115 sign (lower right side in *Figure 4*) have to turn to green.

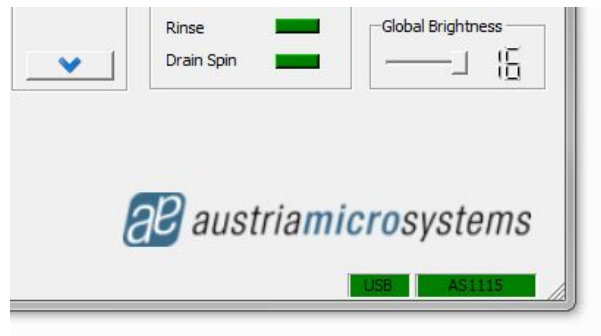

Figure 4: Software Panel detail

Operational sequence

1. If not present get the datasheet for the AS1115 from www.austriamicrosystems.com. Use the IC on the demoboard only with the recommended settings and values as described in the datasheet.
2. First install the AS1115 WGB Software and then connect the demo board with the PC via the USB connector "C". To power down the system simply disconnect the USB cable.
3. For the data format of the I²C interface please see the datasheet of the AS1115.

Have fun using the demoboard. If there are questions do not hesitate to contact us. See contact information at the end of the application note.

Board schematics of the demoboard

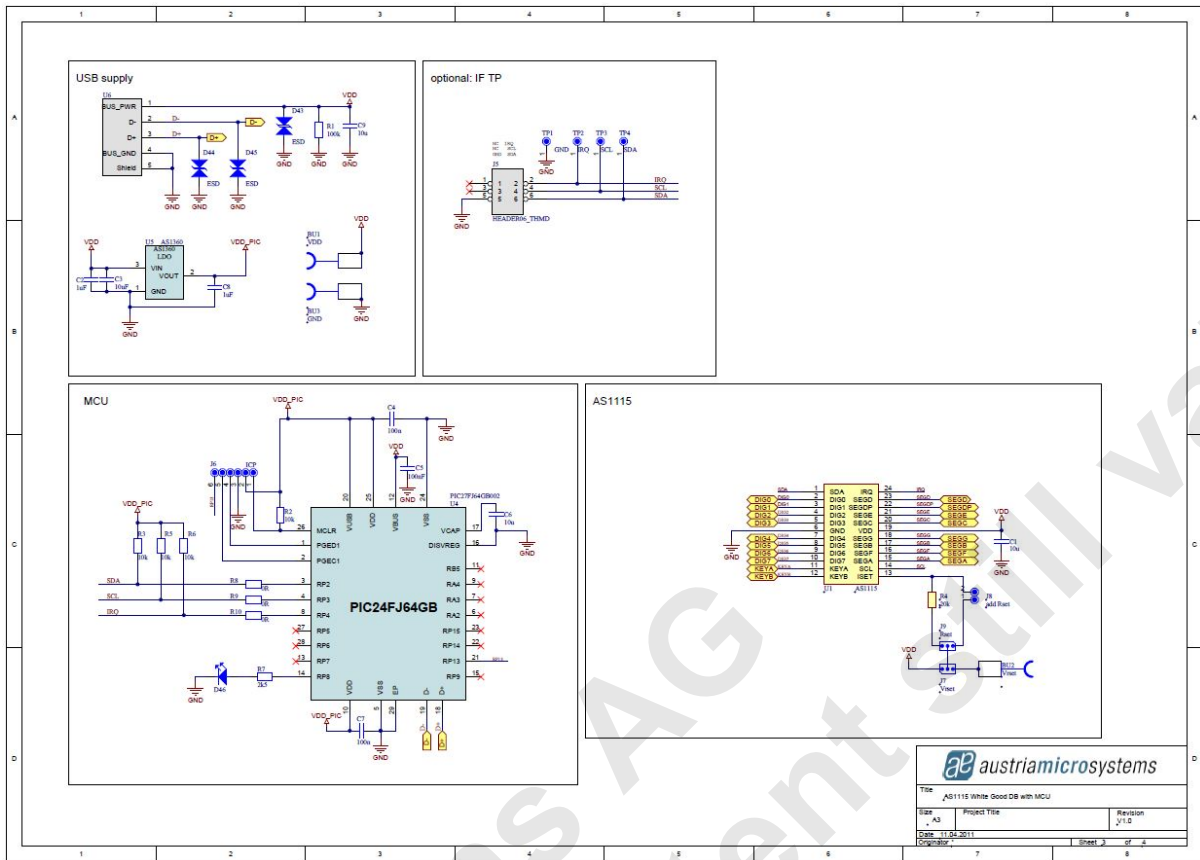

Figure 5: Main Schematic

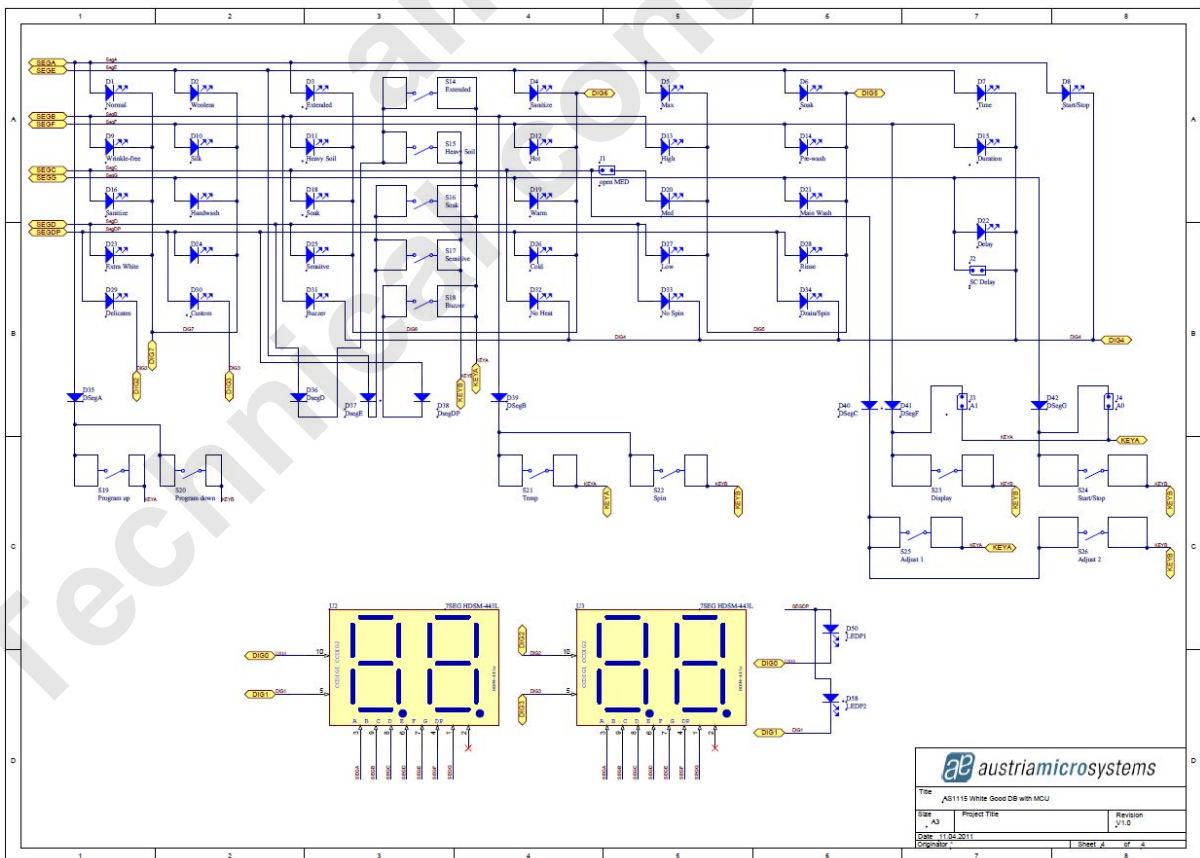

Figure 6: LED Configuration

Layout of the demoboard

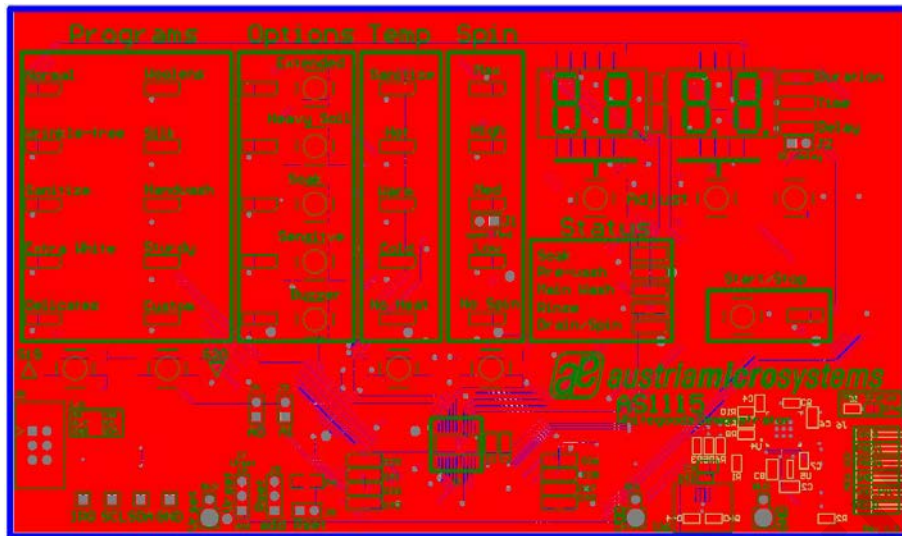

Figure 7: Top view

Copyright

Copyright © 1997-2011, austriamicrosystems AG, Schloss Premstaetten, 8141 Unterpremstaetten, Austria-Europe. Trademarks Registered ®. All rights reserved. The material herein may not be reproduced, adapted, merged, translated, stored, or used without the prior written consent of the copyright owner.

All products and companies mentioned are trademarks or registered trademarks of their respective companies.

Disclaimer

Devices sold by austriamicrosystems AG are covered by the warranty and patent indemnification provisions appearing in its Term of Sale. austriamicrosystems AG makes no warranty, express, statutory, implied, or by description regarding the information set forth herein or regarding the freedom of the described devices from patent infringement. Austriamicrosystems AG reserves the right to change specifications and prices at any time and without notice. Therefore, prior to designing this product into a system, it is necessary to check with austriamicrosystems AG for current information.

This product is intended for use in normal commercial applications. Applications requiring extended temperature range, unusual environmental requirements, or high reliability applications, such as military, medical life-support or lifesustaining equipment are specifically not recommended without additional processing by austriamicrosystems AG for each application. For shipments of less than 100 parts the manufacturing flow might show deviations from the standard production flow, such as test flow or test location.

The information furnished here by austriamicrosystems AG is believed to be correct and accurate. However, austriamicrosystems AG shall not be liable to recipient or any third party for any damages, including but not limited to personal injury, property damage, loss of profits, loss of use, interruption of business or indirect, special, incidental or consequential damages, of any kind, in connection with or arising out of the furnishing, performance or use of the technical data herein. No obligation or liability to recipient or any third party shall arise or flow out of austriamicrosystems AG rendering of technical or other services.



Contact Information

Headquarters

austriamicrosystems AG
Tobelbaderstraße 30
A-8141 Unterpremstätten - Graz, Austria
T. +43 (0) 3136 500 0
F. +43 (0) 3136 5692

For Sales Offices, Distributors and Representatives, please visit:
<http://www.austriamicrosystems.com/contact>

Компания «Life Electronics» занимается поставками электронных компонентов импортного и отечественного производства от производителей и со складов крупных дистрибьюторов Европы, Америки и Азии.

С конца 2013 года компания активно расширяет линейку поставок компонентов по направлению коаксиальный кабель, кварцевые генераторы и конденсаторы (керамические, пленочные, электролитические), за счёт заключения дистрибьюторских договоров

Мы предлагаем:

- Конкурентоспособные цены и скидки постоянным клиентам.
- Специальные условия для постоянных клиентов.
- Подбор аналогов.
- Поставку компонентов в любых объемах, удовлетворяющих вашим потребностям.
- Приемлемые сроки поставки, возможна ускоренная поставка.
- Доставку товара в любую точку России и стран СНГ.
- Комплексную поставку.
- Работу по проектам и поставку образцов.
- Формирование склада под заказчика.
- Сертификаты соответствия на поставляемую продукцию (по желанию клиента).
- Тестирование поставляемой продукции.
- Поставку компонентов, требующих военную и космическую приемку.
- Входной контроль качества.
- Наличие сертификата ISO.

В составе нашей компании организован Конструкторский отдел, призванный помогать разработчикам, и инженерам.

Конструкторский отдел помогает осуществить:

- Регистрацию проекта у производителя компонентов.
- Техническую поддержку проекта.
- Защиту от снятия компонента с производства.
- Оценку стоимости проекта по компонентам.
- Изготовление тестовой платы монтаж и пусконаладочные работы.



Тел: +7 (812) 336 43 04 (многоканальный)
Email: org@lifeelectronics.ru