

Silicon SP4T Surface Mount HMIC PIN Diode Switch 50 MHz - 20 GHz

Rev. V5

Features

- Operates 50 MHz to 20 GHz
- Usable up to 26 GHz
- Low Insertion Loss
- High Isolation
- Low Parasitic Capacitance and Inductance
- RoHS Compliant Surmount Package
- Rugged, Fully Monolithic
- Glass Encapsulated Construction
- Up to +38 dBm C.W. Power Handling @ +25°C
- Silicon Nitride Passivation
- Polymer Scratch Protection
- Solderable

Description

The MASW-004103-1365 is a SP4T, surmount, broadband, monolithic switch using four sets of series and shunt connected PIN diodes. This device is designed for use in broadband, low to moderate signal, high performance, switch applications up to 20 GHz. It is a surface mountable switch configured for optimized performance and offers a distinct advantage over MMIC, beamlead and chip and wire hybrid designs. Because the PIN diodes of the MASW-004103-1365 are integrated into the chip and kept within close proximity, the parasitics typically associated with other designs that use individual components are kept to a minimum.

To minimize the parasitics and achieve high performance the MASW-004103-1365 is fabricated using MACOMs' patented HMIC™ (Heterolithic Microwave Integrated Circuit) process. This process allows the silicon pedestals, which form the series and shunt diodes or vias, to be imbedded in low loss, low dispersion glass. The combination of low loss glass and using tight spacing between elements results in an HMIC device with low loss and high isolation through low millimeter wave frequencies.

The topside is fully encapsulated with silicon nitride and also has an additional layer of polymer for scratch and impact protection. The protective coating guards against damage to the junction and the anode airbridges during handling and assembly.

On the backside of the chip gold metalized pads have been added to produce a solderable surmount device.

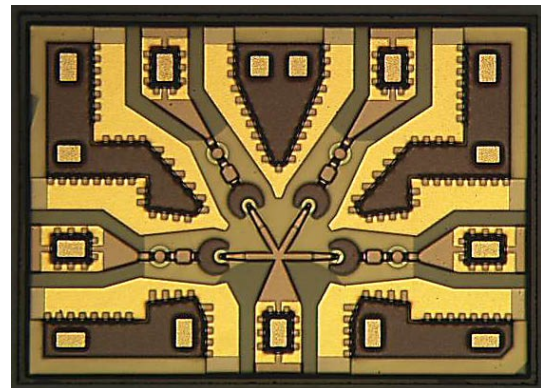

Functional Schematic

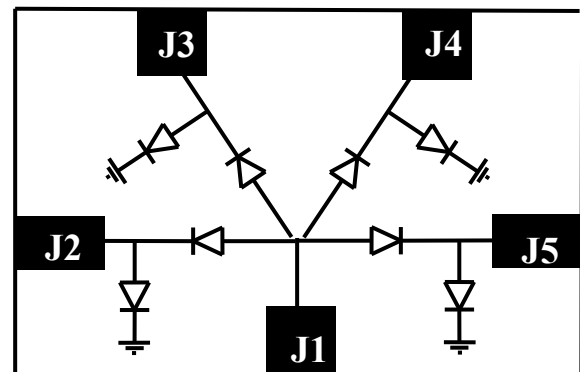

Pin Configuration

Pin	Function
J1	RFC
J2	RF1
J3	RF2
J4	RF3
J5	RF4

Ordering Information

Part Number	Package
MASW-004103-13650G	50 piece gel pack
MASW-004103-13655P	500 piece reel
MASW-004103-13650P	3000 piece reel
MASW-004103-001SMB	Sample Test Board

Silicon SP4T Surface Mount HMIC PIN Diode Switch 50 MHz - 20 GHz

Rev. V5

Electrical Specifications: $T_A = 25^\circ\text{C}$, $P_{IN} = 0\text{ dBm}$, $Z_0 = 50\ \Omega$, 20 mA / -10 V

Parameter	Conditions	Units	Min.	Typ.	Max.
Insertion Loss	6 GHz	dB	—	0.5	0.6
	13 GHz			0.8	1.0
	20 GHz			1.2	1.5
Isolation	6 GHz	dB	48	51	—
	13 GHz		38	39	
	20 GHz		29	32	
Input Return Loss	6 GHz	dB	17	21	—
	13 GHz		13	17	
	20 GHz		12	16	
Output to Output Isolation	6 GHz	dB	—	53.5	—
	13 GHz			41.5	
	20 GHz			31.5	
Input 0.1dB Compression Point	2 GHz	dB	—	36	—
IIP3	0.5 GHz, 5 MHz Spacing, 20 dBm	dBm	—	60	—
	1 GHz, 10 MHz Spacing, 20 dBm			63	
	2 GHz, 10 MHz Spacing, 20 dBm			64	
Switching Speed ¹	—	ns	—	20	—
Voltage Rating ²	—	V	—	—	80

1. Typical Switching Speed measured from 10% to 90 % of detected RF signal driven by TTL compatible drivers.
2. Maximum reverse leakage current in either the shunt or series PIN diodes shall be 0.5 μA maximum @ -80 volts.

Absolute Maximum Ratings^{3,4}

Parameter	Absolute Maximum
Operating Temperature	-65 °C to +125 °C
Storage Temperature	-65 °C to +150 °C
Junction Temperature	+175 °C
Applied Reverse Voltage	-80 V
RF CW Incident Power	38 dBm
	33 dBm
Bias Current +25°C	$\pm 50\text{ mA}$

3. Exceeding any one or combination of these limits may cause permanent damage to this device.
4. MACOM does not recommend sustained operation near these survivability limits.

Combined maximum operating conditions for RF power, DC bias, & temperature: 33 dBm CW, 20 mA per diode, +85°C

Static Sensitivity

These devices are rated at Class 1A Human Body Model. Proper ESD control techniques should be used when handling these devices.

Typical Performance Curves

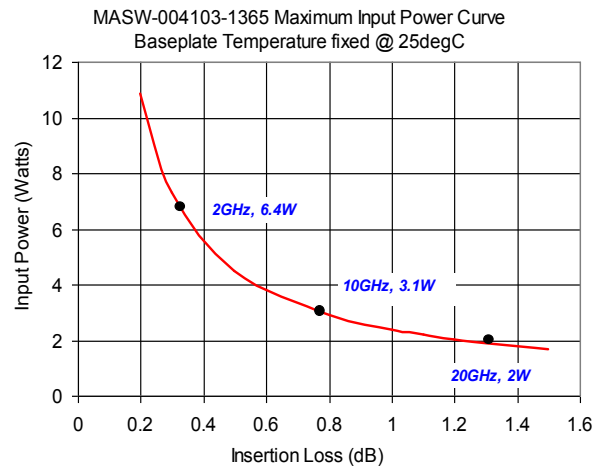
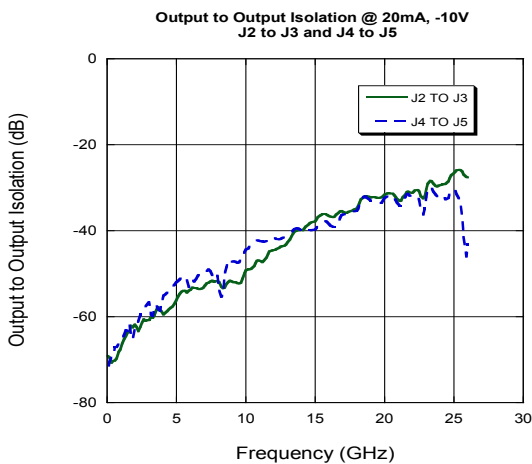
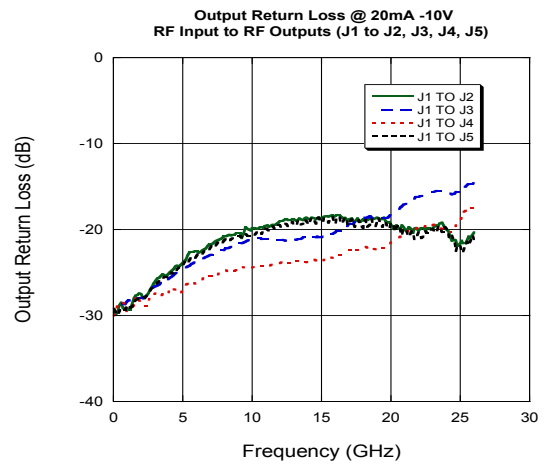
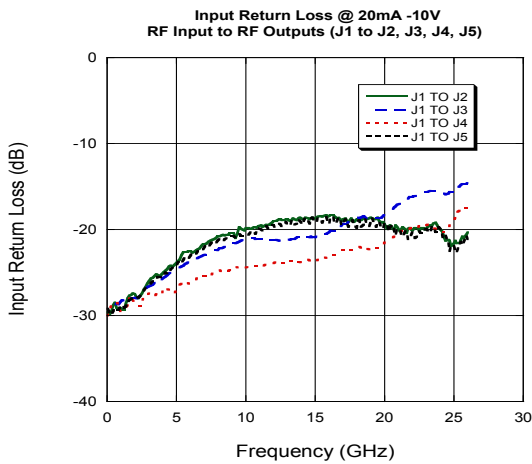
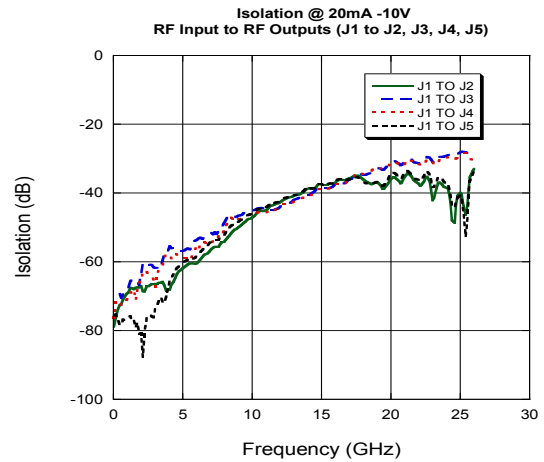
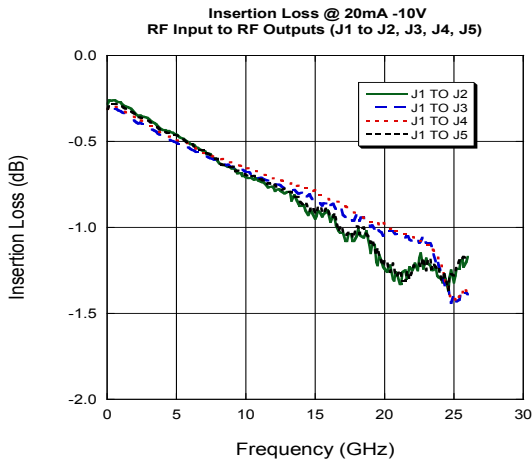

Bias Control

Optimal operation of the MASW-004103-1365 is achieved by simultaneous application of negative DC voltage and current to the low loss switching arm and positive DC voltage and current to the remaining switching arms as shown in the applications circuit below. DC return is achieved via R2 on the RFC path. In the low loss state, the series diode must be forward biased with current and the shunt diode reverse biased with voltage. In the isolated arm, the shunt diode is forward biased with current and the series diode is reverse biased with voltage.

Driver Connections

Control Level (DC Currents and Voltages)				Condition of RF Output			
B2	B3	B4	B5	J1-J2	J1-J3	J1-J4	J1-J5
-15 V at -20 mA ⁵	+6 V at +20 mA	+6 V at +20 mA	+6 V at +20 mA	Low Loss	Isolation	Isolation	Isolation
+6 V at +20 mA	-15 V at -20 mA ⁵	+6 V at +20 mA	+6 V at +20 mA	Isolation	Low Loss	Isolation	Isolation
+6 V at +20 mA	+6 V at +20 mA	-15 V at -20 mA ⁵	+6 V at +20 mA	Isolation	Isolation	Low Loss	Isolation
+6 V at +20 mA	+6 V at +20 mA	+6 V at +20 mA	-15 V at -20 mA ⁵	Isolation	Isolation	Isolation	Low Loss

5. The voltage applied to the off arm is allowed to vary provided a constant current is applied through the shunt diode on the off arm.

Application Circuit^{6,7,8,9,10}

Example:

J1 to J2 → Low Loss
 R1 = 250Ω
 R2 = 450Ω
 B2 = -15V
 B3, B4, B5 = 6V

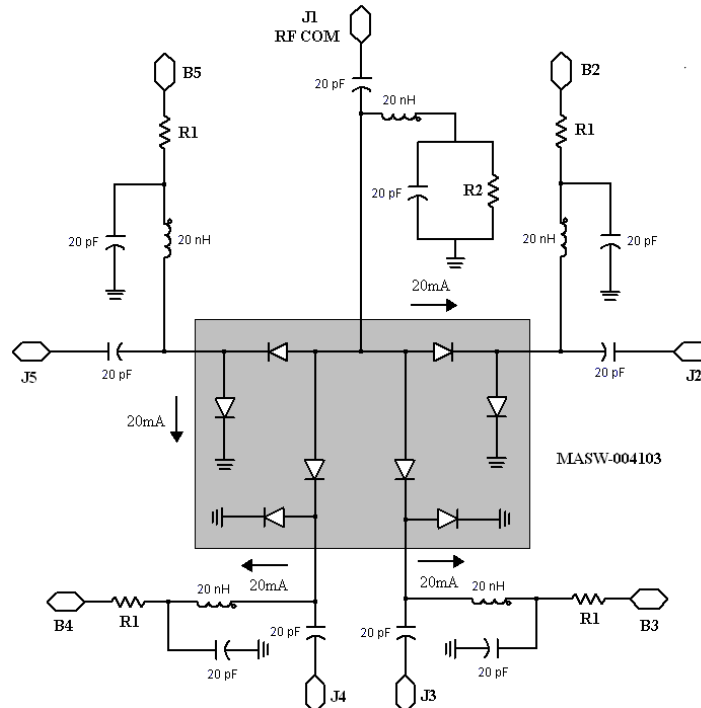

6. Assume $V_f \sim 1\text{ V}$ at 20 mA
7. $R_1 = 5\text{ V} / 0.02\text{ A} = 250\ \Omega$; $R_2 = 9\text{ V} / 0.02\text{ A} = 450\ \Omega$
8. $P_{R_1} = 0.02\text{ A} \times 0.02\text{ A} \times 250 = 0.1\text{ W}$
9. $P_{R_2} = 0.02\text{ A} \times 0.02\text{ A} \times 450 = 0.18\text{ W}$
10. Inductors shown in the above schematic are RF bias chokes. The operating bandwidth of a broad-band PIN diode switch is often dependent on the bias components, particularly the RF bias chokes. It is suggested that the response at the frequencies of interest be measured with all the bias components in place prior to installing of MASW-004103-1365.

4

Sample Board

Samples test boards are available upon request

Handling Procedures

Attachment to a circuit board is made simple through the use of standard surface mount technology. Mounting pads are conveniently located on the bottom of the chip and are removed from the active junction locations making it well suited for solder attachment. Connections may be made onto hard or soft substrates via the use of 80Au/20Sn, or RoHS compliant solders. Typical re-flow profiles for provided in [Application Note M538](#), "Surface Mounting Instructions" and can viewed in the Customer Support, Technical Resources section of the MA-COM Technology Solutions website at www.macomtech.com.

For applications where the average power is $\leq 1W$, a thermally conductive silver epoxy may also be used. Cure per manufacturers recommended time and temperature. Typically 1 hour at 150°C.

When soldering these devices to a hard substrate, a solder re-flow method is preferred. A vacuum pick up tool with a soft tip is recommended while placing the chip . When soldering to soft substrates, such as Duroid, a soft solder is recommended at the circuit board to chip mounting pad interface to minimize stress due to any TCE mismatches that may exist. Position the die so that its mounting pads are aligned with the circuit board land pads. Solder reflow should not be performed by causing heat to flow through the top surface of the die to the back. Since the HMIC glass is transparent, the edges of the mounting pads can be visually inspected through the die after attachment is completed.

PCB Land Pattern (All dims. in μm)

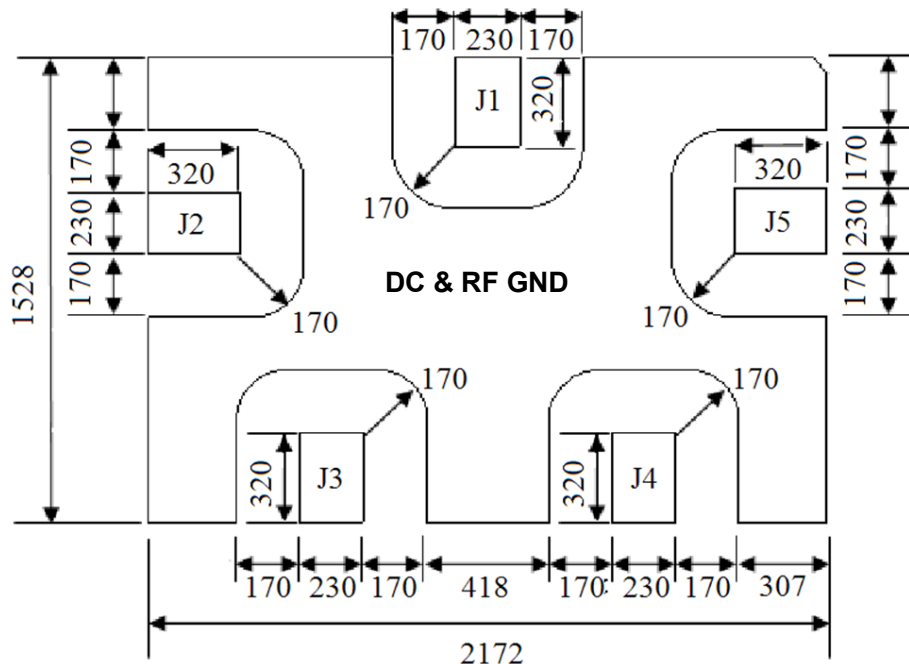

Pocket Tape Information

Carrier Tape Dimensions

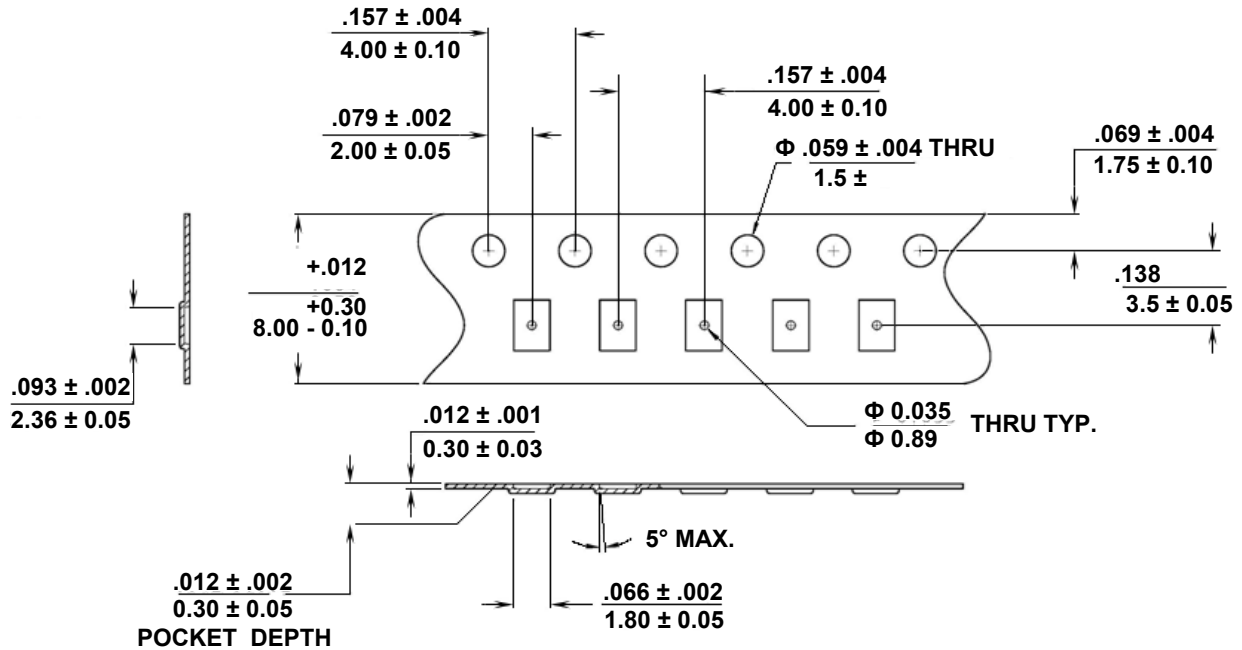

Chip Orientation in Tape

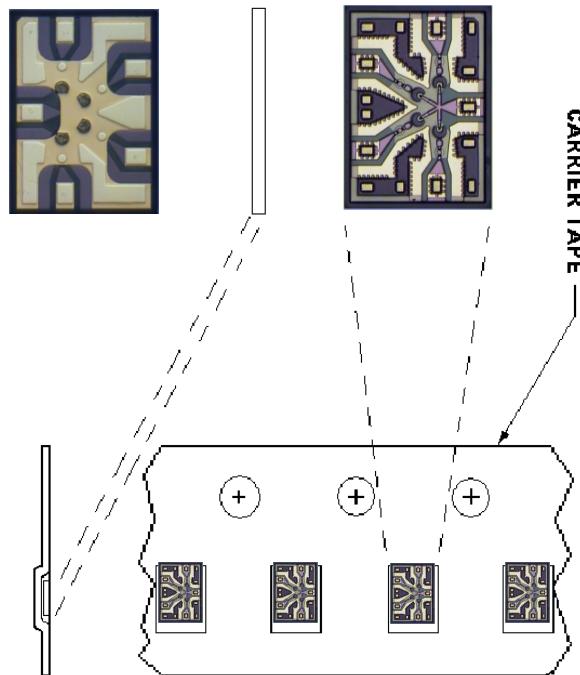

Reel Information

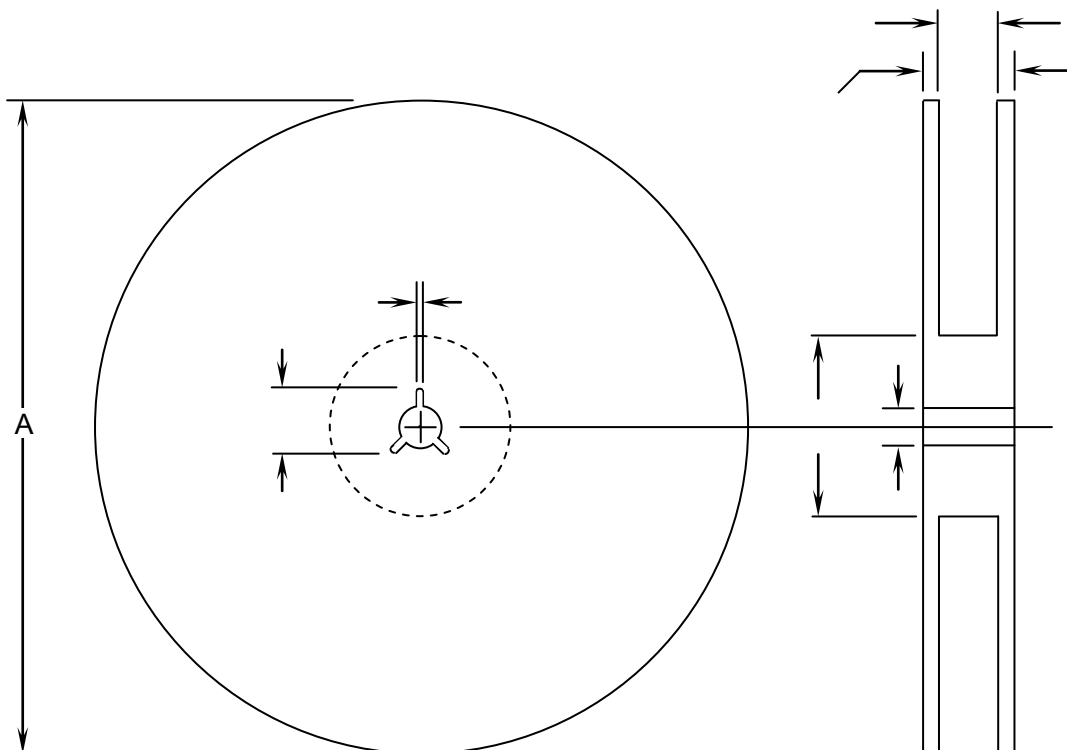

DIM	INCHES		MM	
	MIN.	MAX.	MIN.	MAX.
A	6.980	7.019	177.3	178.3
B	.059	.098	1.5	2.5
C	.504	.520	12.8	13.2
D	.795	.815	20.2	20.7
N	2.146	2.185	54.5	55.5
W ₁	.331	.337	8.4	8.55
W ₂	—	.567	—	14.4

Компания «Life Electronics» занимается поставками электронных компонентов импортного и отечественного производства от производителей и со складов крупных дистрибьюторов Европы, Америки и Азии.

С конца 2013 года компания активно расширяет линейку поставок компонентов по направлению коаксиальный кабель, кварцевые генераторы и конденсаторы (керамические, пленочные, электролитические), за счёт заключения дистрибьюторских договоров

Мы предлагаем:

- Конкуренспособные цены и скидки постоянным клиентам.
- Специальные условия для постоянных клиентов.
- Подбор аналогов.
- Поставку компонентов в любых объемах, удовлетворяющих вашим потребностям.
- Приемлемые сроки поставки, возможна ускоренная поставка.
- Доставку товара в любую точку России и стран СНГ.
- Комплексную поставку.
- Работу по проектам и поставку образцов.
- Формирование склада под заказчика.
- Сертификаты соответствия на поставляемую продукцию (по желанию клиента).
- Тестирование поставляемой продукции.
- Поставку компонентов, требующих военную и космическую приемку.
- Входной контроль качества.
- Наличие сертификата ISO.

В составе нашей компании организован Конструкторский отдел, призванный помогать разработчикам, и инженерам.

Конструкторский отдел помогает осуществить:

- Регистрацию проекта у производителя компонентов.
- Техническую поддержку проекта.
- Защиту от снятия компонента с производства.
- Оценку стоимости проекта по компонентам.
- Изготовление тестовой платы монтаж и пусконаладочные работы.



Тел: +7 (812) 336 43 04 (многоканальный)
Email: org@lifeelectronics.ru