

---

## Li-ION/POLYMER 3/4/5CELL PROTECTOR

---

NO.EA-266-130312

### OVERVIEWS

The R5433V Series are high voltage CMOS-based process protection ICs against over-charge and over-discharge of Li-ion/Li polymer secondary batteries. The R5433V series can detect over-charge voltage, over-discharge voltage of 3, 4 or 5-stacked cells of Li-ion/Li polymer batteries.

The R5433V consists of 10 voltage detectors, a voltage reference unit, an oscillator, a counter, delay circuits, and logic circuits.

When the over-charge voltage is detected, after the IC internally prefixed delay time, the output of  $C_{OUT}$  becomes "Hi-Z" or "H" depending on the output type. When the over-discharge voltage current is detected, after the setting delay time by the internal constant current source and an external capacitor, the output of  $D_{OUT}$  becomes "Hi-Z" or "H" depending on the output type.

After detecting over-charge, when the cell voltage becomes lower than the over-charge released voltage, the over-charge state is released and the output of  $C_{OUT}$  becomes "L". While after detecting over-discharge, when the cell voltage becomes equal or more than the over-discharge released voltage, then the over-discharge state is released, and the output of  $D_{OUT}$  becomes "L".

If breaking wire between the cell and protection board is occurred, the wire breaking is detected, and the output of  $C_{OUT}$  becomes "Hi-Z" or "H" depending on the output type. After detecting the breaking wire, the cell and the protection board is connected again, the breaking wire detector is released and the output of  $C_{OUT}$  becomes "L".

Further, the testing time shortening function of the protection circuit board is built in the IC. By setting voltage level of DS pin as same as  $V_{DD}$ , the output delay time of over-charge can be shortened into approximately 1/100. By setting DS pin at 3.0V, the output delay time of over-discharge can be shortened into approximately 1/100.

The output type of  $C_{OUT}$  and  $D_{OUT}$  can be designated as CMOS type or N-channel open drain type. The output type of the R5433VxxxAA is N-channel open drain type. The output type of the R5433VxxxAB is CMOS output type. The voltage level of the output of CMOS type is in between  $V_{SS}$  and the internal regulator output. Therefore, "H" level is the output of the internal regulator, approximately 3.6V.

## FEATURES

- Manufactured with High Voltage Tolerant Process

Absolute Maximum Rating : 30V

- Low supply current

Under operation, for 5-cell : Typ. 6.0 $\mu$ A

- High accuracy detector threshold

Over-charge detector (Topt=25°C) : ..... $\pm$ 25mV

Over-discharge detector : ..... $\pm$ 2.5%

- Variety of detector threshold

Over-charge detector threshold .....3.6V-4.5V step of 0.005V (V<sub>DET1n</sub>) (n=1,2,3,4,5)

Over-discharge detector threshold.....2.0V-3.0V step of 0.005V (V<sub>DET2n</sub>) (n=1,2,3,4,5)

Over-charge released voltage .....V<sub>DET1n</sub>-0.0V to 0.4V step of 0.05V (V<sub>REL1n</sub>) (n=1,2,3,4,5)

Over-discharge released voltage .....V<sub>DET2n</sub>+(0.0V to 0.7V, step of 0.1V) (V<sub>REL2n</sub>) (n=1,2,3,4,5)  
up to 3.4V

- Setting of Output delay time

Over-charge detector Output Delay .....:1.0s

Over-discharge detector Output Delay .....setting by an external capacitor C<sub>CT</sub>

- Output Delay Time Shortening Function

By setting voltage level of DS pin as same as V<sub>DD</sub>, the output delay time of detect the over-charge voltage can be reduced into approximately 1/100.

By forcing in the range from 2.8V to V<sub>DD</sub>/2-0.5V to DS pin, the delay time for over-charge can be reduced into 4ms and the delay time for over-discharge can be reduced into approximately 1/100.

- Cell unbalance operation

If one of the stacked cells becomes over-charge, and another cell becomes over-discharge, the both outputs of C<sub>OUT</sub> and D<sub>OUT</sub> becomes "Hi-Z" or "H" depending on the output type of the R5433V.

- 0V-battery charge ..... Acceptable
- Over-charge/discharge released condition ..... By cell voltage
- Output of C<sub>OUT</sub>/D<sub>OUT</sub>

N-channel open drain type: Normal state "L" Detected state "Hi-Z"

CMOS output type: Normal state "L" Detected state "H"

CMOS output type: same as 3.6V output regulator CMOS output

- Breaking wire Detector Function

Breaking wire detector function between the protection circuit board and the battery pack

- Small package..... SSOP-16

# BLOCK DIAGRAMS

(R5433VxxxxA)

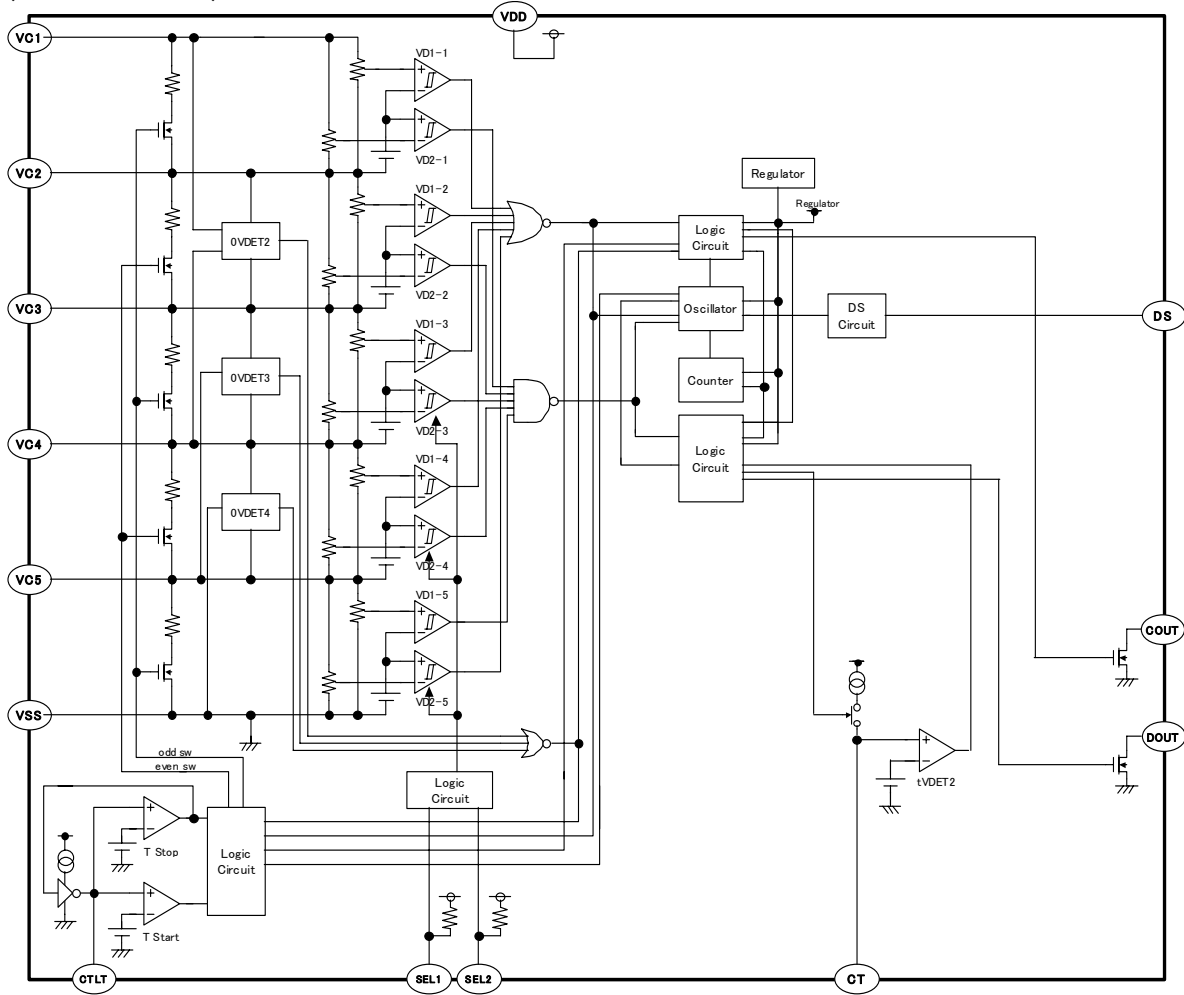

# R5433V

## (R5433VxxxxxB)

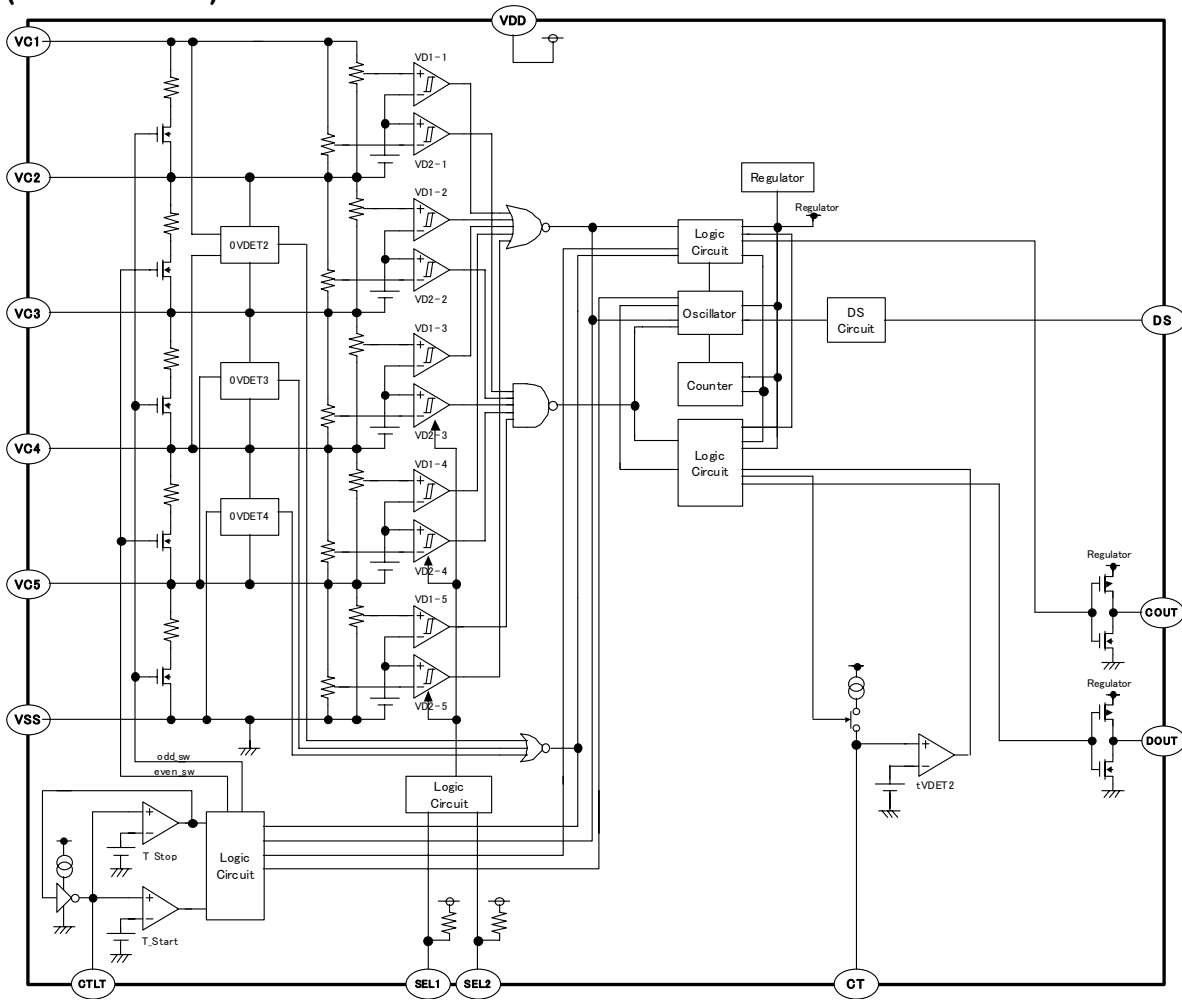

## SELECTION GUIDE

In the R5433Vxxxx Series, input threshold of over-charge, over-discharge, and output delay time can be designated according to the application.

Part Number is designated as follows:

(ex.)

R5433V 301AA ← Part Number

↑ ↑↑↑

a b c d

Code	Contents
a	Package Type V: SSOP-16
b	Serial Number for the R5433 Series designating input threshold for over-charge, over-discharge
c	Designation of Output delay option
d	Designation of version symbols.

### \*Function Table

Code	Output of C <sub>OUT</sub>	Output of D <sub>OUT</sub>	C <sub>OUT</sub> output logic	D <sub>OUT</sub> output logic
R5433VxxxAA	N-channel open drain	N-channel open drain	Normal state: "L" Detected state: "Hi-Z"	Normal state: "L" Detected state: "Hi-Z"
R5433VxxxAB	CMOS	CMOS	Normal state: "L" Detected state: "H"	Normal state: "L" Detected state: "H"

### Delay Time table

Code	Over-charge detector output delay time $tV_{DET1}$ (s)*1	Over-discharge detector output delay time $tV_{DET2}$ (ms)*2
R5433VxxxAA	1.0	$3.64 \times C_{CT}$ (nF)
R5433VxxxAB	1.0	$3.64 \times C_{CT}$ (nF)

\*1: Capacitor for CT pin: C<sub>CT</sub>

\*2: Refer to the item of "OPERATION"

## Product name list

Code	Over charge detector threshold $V_{DET1n}(V) *1$	Over charge Released voltage $V_{REL1n}(V) *1$	Over discharge detector threshold $V_{DET2n}(V) *1$	Over discharge Released voltage $V_{REL2n}(V) *1$
R5433V301AA	4.220	4.150	2.300	2.300
R5433V301AB	4.220	4.150	2.300	2.300
R5433V302AB	4.220	4.150	2.700	2.700
R5433V401AA	4.250	4.050	2.300	3.000
R5433V401AB	4.250	4.050	2.300	3.000
R5433V402AA	4.220	4.150	2.300	3.000
R5433V402AB	4.220	4.150	2.300	3.000
R5433V403AA	4.220	4.150	2.500	3.200
R5433V403AB	4.220	4.150	2.500	3.200

\*1: n=1,2,3,4,5

## PIN CONFIGURATIONS

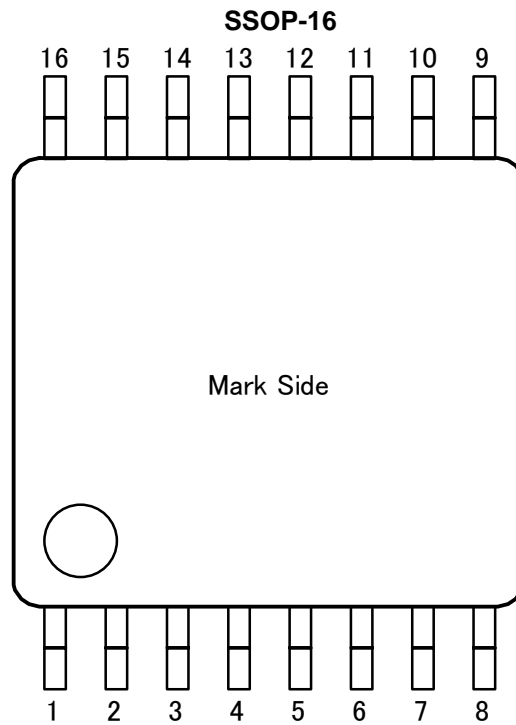

## **PIN DESCRIPTION**

<b>Pin No.</b>	<b>Symbol</b>	<b>Description</b>
1	D <sub>OUT</sub>	Output pin of over-discharge detection
2	C <sub>OUT</sub>	Output pin of over-charge detection
3	SEL2	Selector pin for 3-cell/4-cell/5-cell protection
4	SEL1	Selector pin for 3-cell/4-cell/5-cell protection
5	DS	Output delay time shortening pin
6	CT	Capacitor setting pin for over-discharge delay time
7	CTLT	Capacitor setting pin for time interval of breaking wire detector function
8	V <sub>SS</sub>	V <sub>SS</sub> pin. Ground pin for the IC
9	NC	No Connection
10	NC	No Connection
11	V <sub>C5</sub>	Positive terminal pin for Cell-5
12	V <sub>C4</sub>	Positive terminal Pin for Cell-4
13	V <sub>C3</sub>	Positive terminal Pin for Cell-3
14	V <sub>C2</sub>	Positive terminal pin for Cell-2
15	V <sub>C1</sub>	Positive terminal pin for Cell-1
16	V <sub>DD</sub>	V <sub>DD</sub> Pin

## ABSOLUTE MAXIMUM RATINGS

T<sub>opt</sub>=25°C, V<sub>SS</sub>=0V

Symbol	Item	Ratings	Unit
V <sub>DD</sub>	Supply voltage	-0.3 to 30	V
	Input Voltage		
V <sub>C1</sub>	Positive input pin voltage for Cell-1	V <sub>C2</sub> -0.3 to V <sub>C2</sub> +6.5	V
V <sub>C2</sub>	Positive input pin voltage for Cell-2	V <sub>C3</sub> -0.3 to V <sub>C3</sub> +6.5	
V <sub>C3</sub>	Positive input pin voltage for Cell-3	V <sub>C4</sub> -0.3 to V <sub>C4</sub> +6.5	
V <sub>C4</sub>	Positive input pin voltage for Cell-4	V <sub>C5</sub> -0.3 to V <sub>C5</sub> +6.5	
V <sub>C5</sub>	Positive input pin voltage for Cell-5	-0.3 to 6.5	
V <sub>SEL1</sub>	SEL1 pin voltage	-0.3 to V <sub>DD</sub> +0.3	
V <sub>SEL2</sub>	SEL2 pin voltage	-0.3 to V <sub>DD</sub> +0.3	
V <sub>DS</sub>	DS pin voltage	-0.3 to V <sub>DD</sub> +0.3	
V <sub>CTLT</sub>	CTLT pin voltage	-0.3 to 3.0	
V <sub>CT</sub>	CT pin voltage	-0.3 to 3.0	
	Output voltage(R5433VxxxxA)		
V <sub>COU</sub>	C <sub>OUT</sub> pin voltage	-0.3 to 30	V
V <sub>DOU</sub>	D <sub>OUT</sub> pin voltage	-0.3 to 30	
	Output voltage(R5433VxxxxB)		
V <sub>COU</sub>	C <sub>OUT</sub> pin voltage	-0.3 to V <sub>R</sub> +0.3	V
V <sub>DOU</sub>	D <sub>OUT</sub> pin voltage	-0.3 to V <sub>R</sub> +0.3	
P <sub>D</sub>	Power dissipation	685	mW
T <sub>opt</sub>	Operating temperature range	-40 to 85	°C
T <sub>stg</sub>	Storage temperature range	-55 to 125	°C



## ELECTRICAL CHARACTERISTICS

R5433VxxxAA

Unless otherwise specified, T<sub>opt</sub>=25°C

Symbol	Item	Conditions	Min.	Typ.	Max.	Unit	Test Circuit
V <sub>DD1</sub>	Operating input voltage	Voltage defined as V <sub>DD</sub> -V <sub>SS</sub>	1.7		25.0	V	-
V <sub>DET1n</sub>	CELLn Over-charge threshold (n=1,2,3,4,5)	Detect rising edge of supply voltage	V <sub>DET1n</sub> -0.025	V <sub>DET1n</sub>	V <sub>DET1n</sub> +0.025	V	A
V <sub>REL1n</sub>	CELLn Over-charge released voltage(n=1,2,3,4,5)	Detect falling edge of supply voltage	V <sub>REL1n</sub> -0.050	V <sub>REL1n</sub>	V <sub>REL1n</sub> +0.050	V	A
t <sub>VDET1</sub>	Output delay of over-charge	V <sub>DD</sub> =V <sub>C1</sub> , V <sub>CELLn</sub> =3.5V, V <sub>CELL1</sub> =3.5V to 4.5V (n=2,3,4,5)	0.7	1.0	1.3	s	B
t <sub>VREL1</sub>	Output delay of release from over-charge	V <sub>DD</sub> =V <sub>C1</sub> , V <sub>CELLn</sub> =3.5V, V <sub>CELL1</sub> =4.5V to 3.5V (n=2,3,4,5)	11	16	21	ms	B
V <sub>DET2n</sub>	CELLn Over-discharge threshold (n=1,2,3,4,5)	Detect falling edge of supply voltage	V <sub>DET2n</sub> ×0.975	V <sub>DET2n</sub>	V <sub>DET2n</sub> ×1.025	V	C
V <sub>REL2n</sub>	CELLn Released Voltage from Over-discharge (n=1,2,3,4,5)	Detect rising edge of supply voltage	V <sub>REL2n</sub> ×0.975	V <sub>REL2n</sub>	V <sub>REL2n</sub> ×1.025	V	C
I <sub>CT</sub>	CT pin charge current	V <sub>DD</sub> =V <sub>C1</sub> , V <sub>CELLn</sub> =3.5V(n=2,3,4,5) V <sub>CELL1</sub> =3.5V to 1.5V	350	500	650	nA	D
V <sub>DCT</sub>	CT pin detector threshold	V <sub>DD</sub> =V <sub>C1</sub> , V <sub>CELLn</sub> =3.2V(n=2,3,4,5) V <sub>CELL1</sub> =3.5V to 1.5V	1.48	1.80	2.22	V	E
t <sub>VDET2</sub>	Output delay of over-discharge	t <sub>VDET2</sub> =C <sub>CT</sub> × V <sub>DCT</sub> /I <sub>CT</sub> , C <sub>CT</sub> =0.33uF	0.8	1.2	1.6	s	-
t <sub>VREL2</sub>	Output delay of release from over-discharge	V <sub>DD</sub> =V <sub>C1</sub> , V <sub>CELLn</sub> =3.5V V <sub>CELL1</sub> =1.5V to 3.5V, (n=2,3,4,5)	0.7	1.2	1.7	ms	F
I <sub>CTLT</sub>	CTLT pin charge current	V <sub>DD</sub> =V <sub>C1</sub> , V <sub>CELLn</sub> =3.5V(n=1,2,3,4,5)	145	200	264	nA	G
V <sub>DTLT</sub>	CTLT pin detector threshold	V <sub>DD</sub> =V <sub>C1</sub> V <sub>CELLn</sub> =3.2V(n=1,2,4,5) V <sub>C3</sub> =VD1+0.25V	1.58	1.80	2.42	V	H
V <sub>RTLT</sub>	CTLT pin released voltage	V <sub>DD</sub> =V <sub>C1</sub> V <sub>CELLn</sub> =3.2V(n=1,2,3,4,5)	0.07	0.13	0.19	V	H
t <sub>LT</sub>	Test interval of breaking wire detector	C <sub>CTLT</sub> =3.3uF, TLT=C <sub>CTLT</sub> × (V <sub>DCT</sub> -V <sub>RTL</sub> )/I <sub>CTLT</sub>	21	30	39	s	-
V <sub>IH1</sub>	SEL1 pin "H" input voltage	V <sub>DD</sub> =V <sub>C1</sub> , V <sub>CELLn</sub> =3.2V (n=1,2,3,4,5)	7.7		V <sub>DD</sub> +0.3	V	I
V <sub>IL1</sub>	SEL1 pin "L" input voltage	V <sub>DD</sub> =V <sub>C1</sub> , V <sub>CELLn</sub> =3.2V (n=1,2,3,4,5)	V <sub>SS</sub> -0.3		V <sub>SS</sub> +1.0	V	I
V <sub>IH2</sub>	SEL2 pin "H" input voltage	V <sub>DD</sub> =V <sub>C1</sub> , V <sub>CELLn</sub> =3.2V (n=1,2,3,4,5)	7.7		V <sub>DD</sub> +0.3	V	J
V <sub>IL2</sub>	SEL2 pin "L" input voltage	V <sub>DD</sub> =V <sub>C1</sub> , V <sub>CELLn</sub> =3.2V (n=1,2,3,4,5)	V <sub>SS</sub> -0.3		V <sub>SS</sub> +1.0	V	J
V <sub>IH3</sub>	DS pin "H" input voltage	V <sub>DD</sub> =V <sub>C1</sub> , V <sub>CELLn</sub> =3.5V (n=2,3,4,5), V <sub>CELLn</sub> =4.5V to 3.0V	14.0		V <sub>DD</sub> +0.3	V	K
V <sub>IM3</sub>	DS pin "Middle" input voltage	V <sub>DD</sub> =V <sub>C1</sub> , V <sub>CELLn</sub> =3.5V (n=2,3,4,5), V <sub>CELL1</sub> =4.5V to 3.0V (Max side) V <sub>CELL1</sub> =3.5V to 1.5V (Min side)	2.8		5.9	V	K, L
V <sub>IL3</sub>	DS pin "L" input voltage	V <sub>DD</sub> =V <sub>C1</sub> , V <sub>CELLn</sub> =3.5V (n=2,3,4,5), V <sub>CELL1</sub> =3.5V to 1.5V	V <sub>SS</sub> -0.3		0.9	V	L

\*Note: V<sub>CELLn</sub> means Cell-n's voltage. n=1,2,3,4,5

---

**R5433V**

---

Symbol	Item	Conditions	Min.	Typ.	Max.	Unit	Test Circuit
VOL1	COUT N-channel ON voltage	$I_{OL}=50\mu A, V_{DD}=VC1, V_{CELLn}=3.2V,$ (n=1,2,3,4,5)		0.1	0.5	V	M
VOL2	DOUT N-channel ON voltage	$I_{OL}=50\mu A, V_{DD}=VC1,$ $V_{CELLn}=3.2V, (n=1,2,3,4,5)$		0.1	0.5	V	N
ILCOUT	COUT open-drain pin off leakage current	$V_{DD}=VC1, V_{CELLn}=6.0V$ (n=1,2,3,4,5) COUT=30.0V	-0.2		0.2	$\mu A$	O
ILDOUT	DOUT open-drain pin off leakage current	$V_{DD}=VC1, V_{CELLn}=1.5V,$ (n=1,2,3,4,5), COUT=30.0V	-0.2		0.2	$\mu A$	P
ISS1	Supply current1	$V_{DD}=VC1, COUT=VSS,$ DOUT = VSS, $V_{CELLn}=V_{DET1n}-0.4V$ (n=1,2,3,4,5)		6.0	15.0	$\mu A$	a
ISS2	Supply current2	$V_{DD}=VC1, COUT=VSS,$ DOUT = VSS, $V_{CELLn}=1.5V$ (n=1,2,3,4,5)		5.0	13.0	$\mu A$	a

\*Note: VCELLn means Cell-n's voltage. n=1,2,3,4,5

## R5433VxxxAB

Unless otherwise specified, T<sub>opt</sub>=25°C

Symbol	Item	Conditions	Min.	Typ.	Max.	Unit	Test Circuit
VDD1	Operating input voltage	Voltage defined as VDD-VSS	1.7		25.0	V	-
VDET1 n	CELLn Over-charge threshold (n=1,2,3,4,5)	Detect rising edge of supply voltage	VDET1n- 0.025	VDET1n	VDET1n + 0.025	V	A
VREL1 n	CELLn Over-charge released voltage(n=1,2,3,4,5)	Detect falling edge of supply voltage	VREL1n- 0.050	VREL1n	VREL1n+ 0.050	V	A
tVDET1	Output delay of over-charge	V <sub>DD</sub> =V <sub>C1</sub> , V <sub>CELLn</sub> =3.5V, V <sub>CELL1</sub> =3.5V to 4.5V (n=2,3,4,5)	0.7	1.0	1.3	s	B
tVREL1	Output delay of release from over-charge	V <sub>DD</sub> =V <sub>C1</sub> , V <sub>CELLn</sub> =3.5V, V <sub>CELL1</sub> =4.5V to 3.5V (n=2,3,4,5)	11	16	21	ms	B
VDET2 n	CELLn Over-discharge threshold (n=1,2,3,4,5)	Detect falling edge of supply voltage	VDET2n× 0.975	VDET2n	VDET2n× 1.025	V	C
VREL2 n	CELLn Released Voltage from Over-discharge (n=1,2,3,4,5)	Detect rising edge of supply voltage	VREL2n× 0.975	VREL2n	VREL2n× 1.025	V	C
ICT	CT pin charge current	V <sub>DD</sub> =V <sub>C1</sub> , V <sub>CELLn</sub> =3.5V(n=2,3,4,5) V <sub>CELL1</sub> =3.5V to 1.5V	350	500	650	nA	D
VDCT	CT pin detector threshold	V <sub>DD</sub> =V <sub>C1</sub> , V <sub>CELLn</sub> =3.2V(n=2,3,4,5) V <sub>CELL1</sub> =3.5V to 1.5V	1.48	1.80	2.22	V	E
tVDET2	Output delay of over-discharge	tVDET2=C <sub>CT</sub> × V <sub>DCT</sub> /I <sub>CT</sub> , C <sub>CT</sub> =0.33uF	0.8	1.2	1.6	s	-
tVREL2	Output delay of release from over-discharge	V <sub>DD</sub> =V <sub>C1</sub> , V <sub>CELLn</sub> =3.5V V <sub>CELL1</sub> =1.5V to 3.5V, (n=2,3,4,5)	0.7	1.2	1.7	ms	F
ICTLT	CTLT pin charge current	V <sub>DD</sub> =V <sub>C1</sub> , V <sub>CELLn</sub> =3.5V(n=1,2,3,4,5)	145	200	264	nA	G
VDTLT	CTLT pin detector threshold	V <sub>DD</sub> =V <sub>C1</sub> V <sub>CELLn</sub> =3.2V(n=1,2,4,5) V <sub>C3</sub> =VD1+0.25V	1.58	1.80	2.42	V	H
VRTLTL	CTLT pin released voltage	V <sub>DD</sub> =V <sub>C1</sub> V <sub>CELLn</sub> =3.2V(n=1,2,3,4,5)	0.07	0.13	0.19	V	H
tLT	Test interval of breaking wire detector	C <sub>CTLT</sub> =3.3uF, TLT=C <sub>CTLT</sub> ×(VDCT-VRTLTL)/ICTL T	21	30	39	s	-
VIH1	SEL1 pin "H" input voltage	V <sub>DD</sub> =V <sub>C1</sub> , V <sub>CELLn</sub> =3.2V (n=1,2,3,4,5)	7.7		V <sub>DD</sub> +0.3	V	I
VIL1	SEL1 pin "L" input voltage	V <sub>DD</sub> =V <sub>C1</sub> , V <sub>CELLn</sub> =3.2V (n=1,2,3,4,5)	V <sub>SS</sub> -0.3		V <sub>SS</sub> +1.0	V	I
VIH2	SEL2 pin "H" input voltage	V <sub>DD</sub> =V <sub>C1</sub> , V <sub>CELLn</sub> =3.2V (n=1,2,3,4,5)	7.7		V <sub>DD</sub> +0.3	V	J
VIL2	SEL2 pin "L" input voltage	V <sub>DD</sub> =V <sub>C1</sub> , V <sub>CELLn</sub> =3.2V (n=1,2,3,4,5)	V <sub>SS</sub> -0.3		V <sub>SS</sub> +1.0	V	J
VIH3	DS pin "H" input voltage	V <sub>DD</sub> =V <sub>C1</sub> , V <sub>CELLn</sub> =3.5V (n=2,3,4,5), V <sub>CELLn</sub> =4.5V to 3.0V	14.0		V <sub>DD</sub> +0.3	V	K
VIM3	DS pin "Middle" input voltage	V <sub>DD</sub> =V <sub>C1</sub> , V <sub>CELLn</sub> =3.5V (n=2,3,4,5), V <sub>CELL1</sub> =4.5V to 3.0V (Max side) V <sub>CELL1</sub> =3.5V to 1.5V (Min side)	2.8		5.9	V	K, L
VIL3	DS pin "L" input voltage	V <sub>DD</sub> =V <sub>C1</sub> , V <sub>CELLn</sub> =3.5V (n=2,3,4,5), V <sub>CELL1</sub> =3.5V to 1.5V	V <sub>SS</sub> -0.3		0.9	V	L

\*Note: VCELLn means Cell-n's voltage. n=1,2,3,4,5

---

**R5433V**

---

Symbol	Item	Conditions	Min.	Typ.	Max.	Unit	Test Circuit
VOL1	COUT N-channel ON voltage	$I_{OL}=50\mu A, V_{DD}=VC1$ $V_{CELLn}=3.2V, (n=1,2,3,4,5)$		0.1	0.5	V	M
VOL2	DOUT N-channel ON voltage	$I_{OL}=50\mu A, V_{DD}=VC1$ $V_{CELLn}=3.2V, (n=1,2,3,4,5)$		0.1	0.5	V	N
VR	Internal regulator voltage	$I_{OH}=0\mu A, V_{DD}=VC1,$ $V_{CELL1}=1.5V,$ $V_{CELLn}=3.2V, (n=2,3,4,5)$	3.0	3.7	4.5	V	O
VOH1	COUT P-channel ON voltage	$I_{OH}=-50\mu A, V_{DD}=VC1,$ $V_{CELL1}=4.5V,$ $V_{CELLn}=3.2V, (n=2,3,4,5)$	VR-0.5	VR-0.1		V	M
VOH2	DOUT P-channel ON voltage	$I_{OH}=-50\mu A, V_{DD}=VC1,$ $V_{CELL1}=1.5V,$ $V_{CELLn}=3.2V, (n=2,3,4,5)$	VR-0.5	VR-0.1		V	N
ISS1	Supply current1	$V_{DD}=VC1,$ $V_{CELLn}=V_{DET1n}-0.4V$ $(n=1,2,3,4,5)$		6.0	15.0	$\mu A$	a
ISS2	Supply current2	$V_{DD}=VC1, V_{CELLn}=1.5V$ $(n=1,2,3,4,5)$		5.0	13.0	$\mu A$	a

\*Note: VCELLn means Cell-n's voltage. n=1,2,3,4,5

## **OPERATION**

### **• VDET1n / Over-Charge Detectors (n=1, 2, 3, 4, 5)**

While the cell is charged, the voltage between VC1 pin and VC2 pin (voltage of the Cell-1), the voltage between VC2 pin and VC3 pin (voltage of the Cell-2), the voltage between VC3 pin and VC4 pin (voltage of the Cell-3), the voltage of VC4 pin and VC5 pin (voltage of Cell-4), and the voltage between VC5 pin and VSS pin (voltage of the Cell-5) are supervised. If at least one of the cells' voltage becomes equal or more than the over-charge detector threshold, the over-charge is detected, and C<sub>OUT</sub> pin connected to an external pull up resistance outputs "H"-R5433VxxxAA or without pull-up resistance outputs "H"-R5433VxxxAB. As for the R5433VxxxAB, the output type of C<sub>OUT</sub> pin is CMOS between VSS and internal regulator, and "H" voltage level is the output of the internal regulator, approximately 3.6V.

To reset the over-charge and make the C<sub>OUT</sub> pin level to "H" again after detecting over-charge, in such conditions that a time when all the cells' voltages becomes lower than the over-charge released voltage. The output voltage of C<sub>OUT</sub> pin becomes "L". The over-charge detectors have hysteresis.

Internal fixed output delay times for over-charge detection and release from over-charge exist. Even if one of cells keeps its level more than the over-charge detector threshold, and output delay time passes, over-charge voltage is detected. Even when the voltage of each cell becomes equal or higher level than V<sub>DET1</sub> if these voltages would be back to a level lower than the over-charge detector threshold within a time period of the output delay time, the over-charge is not detected. Besides, after detecting over-charge, each cell voltage is lower than the over-charge detector released voltage, even if just one of cells' voltage becomes equal or more than the over-charge released voltage within the released output delay time, over-charge is not released.

### **• VDET2n / Over-Discharge Detectors (n=1, 2, 3, 4, 5)**

While the cells are discharged, the voltage between VC1 pin and VC2 pin (the voltage of Cell-1), the voltage between VC2 pin and VC3 pin (Cell-2 voltage), the voltage between VC3 pin and VC4 pin (Cell-3 voltage), the voltage between VC4 pin and VC5 pin (Cell-4 voltage), and the voltage between VC5 pin and Vss pin (Cell-5 voltage) are supervised. If at least one of the cells' voltage becomes equal or less than the over-discharge detector threshold, the over-discharge is detected, and DOUT pin outputs "H".

R5433VxxxAA: D<sub>out</sub> is connected to an external pull up resistance, and outputs "H".

R5433VxxxAB: D<sub>out</sub> is not connected to any pull-up resistance, and outputs "H". The output type of DOUT pin is CMOS type between VSS and the internal regulator output. "H" level of DOUT is the output of the internal regulator, approximately 3.6V.

The condition to release over-discharge voltage detector is that after detecting over-discharge voltage, all the cells' voltage becomes higher than the over-discharge released voltage, DOUT pin becomes "L" level. The over-discharge detectors have hysteresis.

The output delay time for over-discharge detect is set with an external capacitor CCT connected to CT pin. If at least one of the cells' voltage becomes down to equal or lower than the over-discharge detector threshold, if the voltage of each cell would be back to a level higher than the over-discharge detector threshold within a time period of the output delay time, the over-discharge is not detected. Output delay time for release from over-discharge is also set internally.

After detecting over-discharge, supply current would be reduced and be into standby by halting unnecessary circuits. The consumption current of the IC itself is reduced as small as possible.

- **SEL1, SEL2 pin**

SEL1 and SEL2 pins are used as switch over 3-cell protector, 4-cell protector and 5-cell protector. If 4-cell protection is selected, by forcing VSS voltage level to SEL1 pin and forcing VDD voltage level to SEL2 pin, the operation of 5th cell's protection circuit stops, and the signal is shut down, therefore, even if the VC5 is shortened to GND, over-discharge is not detected and operates as a 4-cell protector IC.

3-cell protection is selected, by forcing VDD voltage level to SEL1 pin, VSS voltage level to SEL2 pin, the operation of 5th cell and 4th cell stop, and the signal is cut off. Therefore, even if VC4, VC5 and VSS are shorted, over-discharge is not detected and operates as a 3-cell protector IC.

Pull-up resistance is built in the SEL1 pin and SEL2 pin. If they are open, the level becomes VDD.

- **SEL1 and SEL2 pin input and operation mode**

SEL1 pin input	SEL2 pin input	Operation mode
"H"	"H"	5-cell protector
"L"	"H"	4-cell protector
"H"	"L"	3-cell protector
"L"	"L"	Prohibited

- **tVDET2 setting**

CT pin is used for setting the output delay time of over-discharge (tVDET2) by connecting an external capacitor C<sub>CT</sub>.

tVDET2 can be set according to the equation of  $CV=i\Delta t$ .

tVDET2 external capacitor C<sub>CT</sub> setting

tVDET2 can be set as in the next formula.

$$tVDET2(\text{ms})=C_{CT}(\text{nF})\times 3.64$$

For example, if C<sub>CT</sub>=330nF, tVDET2 =1201ms

### • Breaking Wire Detector Function

In the next figure, the breaking wire detector function is applied to the areas named as B+, B1, B2, B3, B4, and B-.

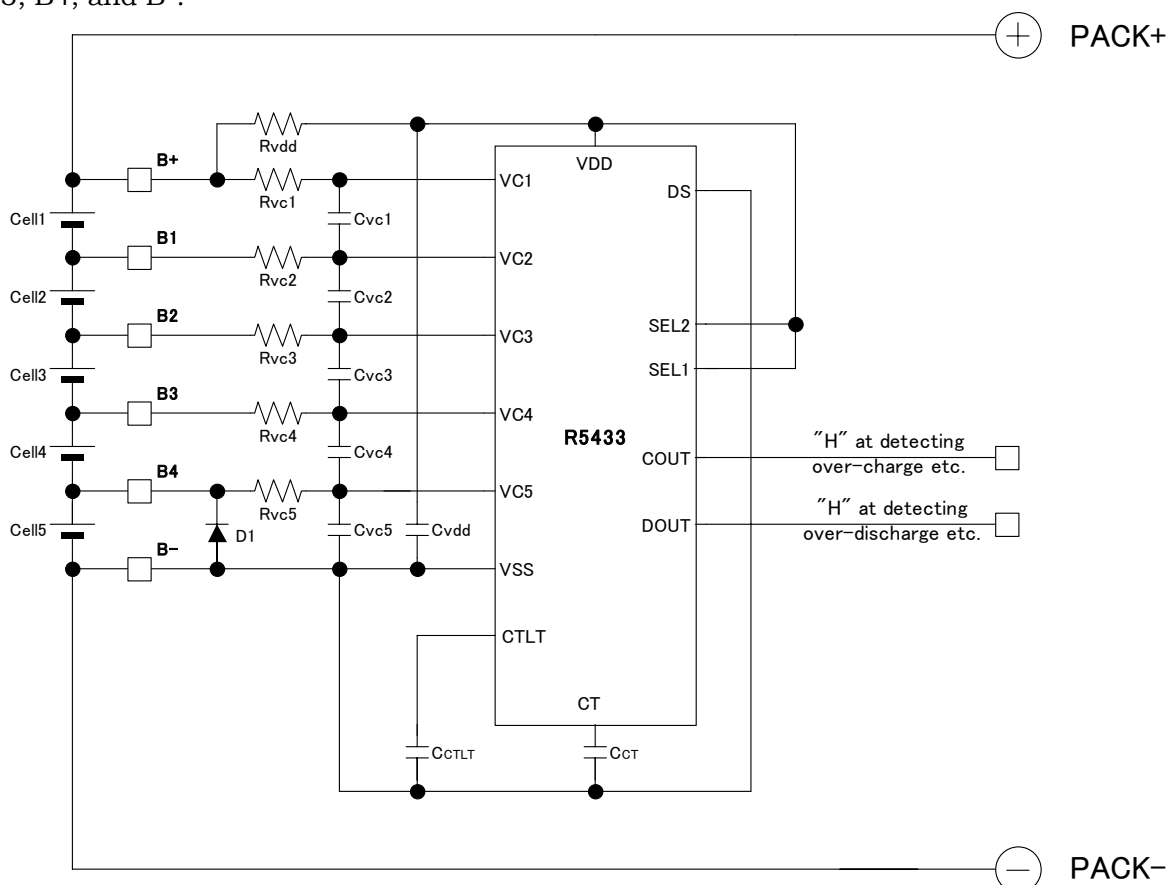

#### Breaking wire detector function for "B+" and "B-" as in 5-cell protector

If the breaking wire at "B+" is detected, the voltage between  $V_{C1}$  and  $V_{C2}$  becomes equal or less than 0V.

If the breaking wire at "B-" is detected, the voltage between  $V_{C5}$  and  $V_{SS}$  becomes equal or less than 0V.

The voltage shift is detected by the 0V-detector circuit.

If the breaking wire is detected,  $C_{OUT}$  pin connected to an external pull up resistance outputs "H"-R5433VxxxAA or without pull-up resistance outputs "H"-R5433VxxxAB. As for the R5433VxxxAB, the output type of  $C_{OUT}$  pin is CMOS between  $V_{SS}$  and internal regulator, and "H" voltage level is the output of the internal regulator, approximately 3.6V.

#### Breaking wire detector function for "B1", "B2", "B3", and "B4" as in 5-cell protector

In case of the 3.3uF capacitor is attached to the CTLT pin, breaking wire detector operates every 30 seconds.

The breaking wire test time is for about 1s in 30 seconds. During the breaking wire testing, built in switch of  $V_{C1}$ ,  $V_{C3}$ ,  $V_{C5}$  cell, and the switch attached to the  $V_{C2}$  and  $V_{C4}$  turn on alternatively by the even\_sw and the odd\_sw signal. The internal impedance of the cell whose switch turns on becomes low. If the wire is broken,

VC shifts by the difference of internal impedance and the shift is detected by the comparator for VDET1. If the breaking wire is detected, the C<sub>OUT</sub> pin of the R5433VxxxAA outputs "H" via an external pull-up resistance. While the output type of C<sub>OUT</sub> pin of the R5433VxxxAB is CMOS between V<sub>SS</sub> and internal regulator, and the "H" level is the output voltage of the internal regulator, approximately, 3.6V.

**\*Technical notes on breaking wire detector function**

During the breaking wire test, even if the cell voltage becomes equal or more than the over-charge detector threshold, the over-charge detector does not operate. In this case, after the breaking wire test, if the cell voltage keeps its level equal or more than the over-charge detector threshold, then over-charge detector starts. Because of this reason, the output delay time of over-charge detector may be longer than t<sub>VDET1</sub>.

During the breaking wire test, even if the cell voltage becomes equal or less than the over-discharge detector threshold, over-discharge detector does not operate. In this case, after the breaking wire test, if the cell voltage keeps its level equal or less than the over-discharge detector threshold, then over-discharge detector starts. Because of this reason, the output delay time of over-discharge may be longer than t<sub>VDET2</sub>.

If over-charge is detected, the breaking wire test is cancelled. When the cell voltage becomes lower than the over-charge released voltage and over-charge is released, then breaking wire test is restarted.

If over-discharge is detected, the breaking wire test is cancelled. When the cell voltage is less than 3.0V, the breaking wire may not be detected.

When the B- wire is broken, the minimum input voltage of the IC is same as the input voltage of V<sub>C5</sub> pin. Therefore, the output of C<sub>OUT</sub> and D<sub>OUT</sub> is more than V<sub>C5</sub> pin voltage. If some external components are connected to C<sub>OUT</sub> pin or D<sub>OUT</sub> pin, and the GND level of the components is the negative terminal of the battery pack, then the voltage rating must be considered.

**• DS (Delay shortening) function**

By setting DS pin level as same as V<sub>DD</sub>, over-charge detector output delay time can be shortened into about 1/100.

By forcing the voltage ranging from 2.8V to V<sub>DD</sub>/2-0.5 to DS pin, the output delay time of over-charge can be shortened into approximately 4ms, and the output delay time of over-discharge can be shortened into approximately 1/100.



# TIMING CHART

(1)Timing diagram of over-charge and over-discharge operation

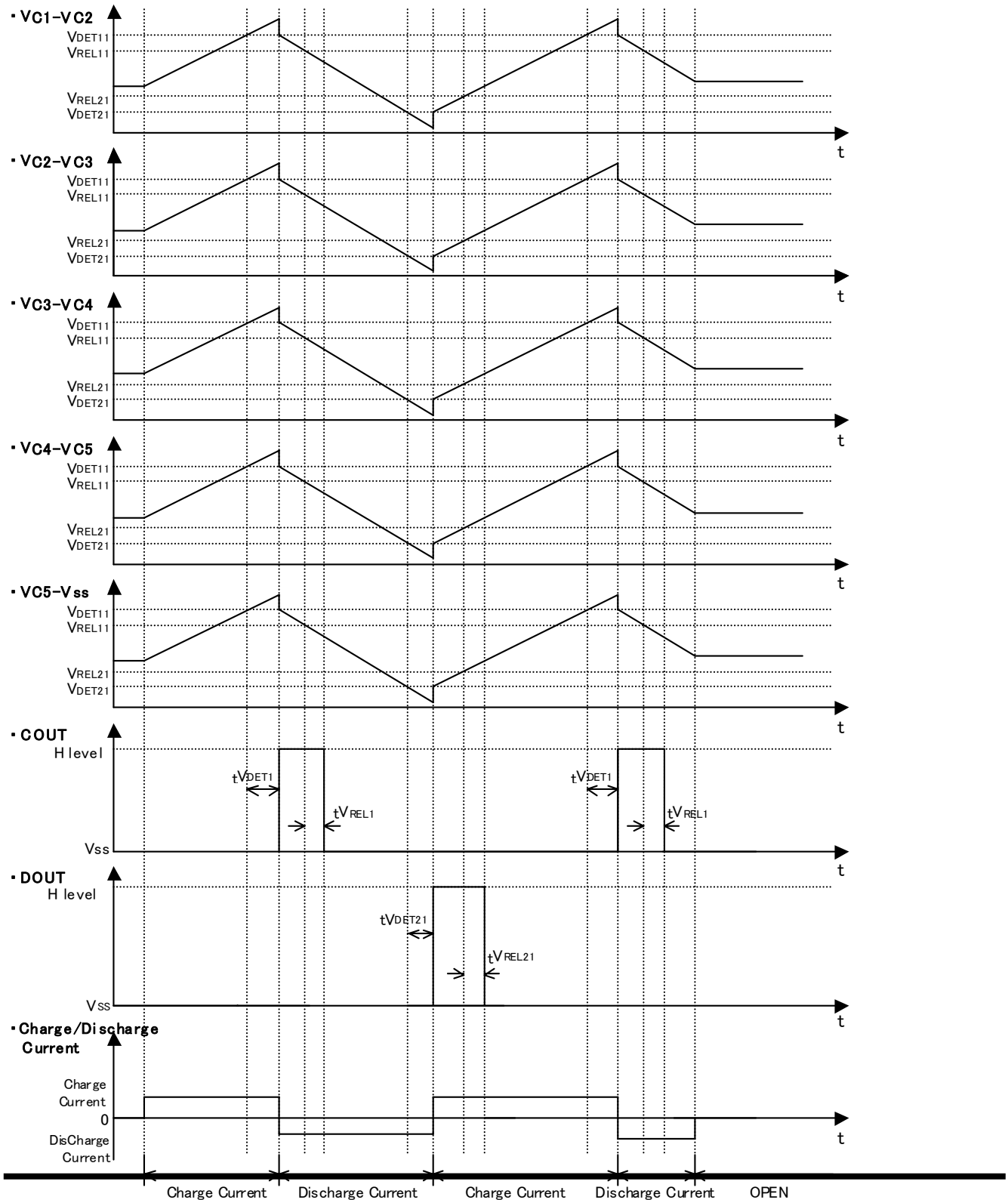

**(2) Breaking wire detector operation**

Breaking wire detector's operation of B1, B2, B3, and B4 for 5-cell protector

By attachment 3.3uF capacitor to the CTLT pin, breaking wire detector operates every 30 seconds. The built in switch of VC1, VC3, VC5 cell, and the switch attached to the VC2 and VC4 turn on alternatively by the even\_sw and the odd\_sw signal.

The internal impedance of the cell whose switch turns on becomes low by the low resistance connected to the switch in serial. If the wire is broken, the difference of internal impedance of the IC, VC value shifts, and the comparator, COMP for VDET1 detects the breaking wire, then, the output of COUT of the R5433VxxxAA becomes "H". The R5433VxxxAA outputs "H" from COUT via an external pull-up resistor. Without the pull-up resistance, the R5433VxxxAB, COUT outputs "H". The output type of COUT of R5433VxxxAB is CMOS between VSS and internal regulator.

The timing chart of breaking wire of B2 is shown below:

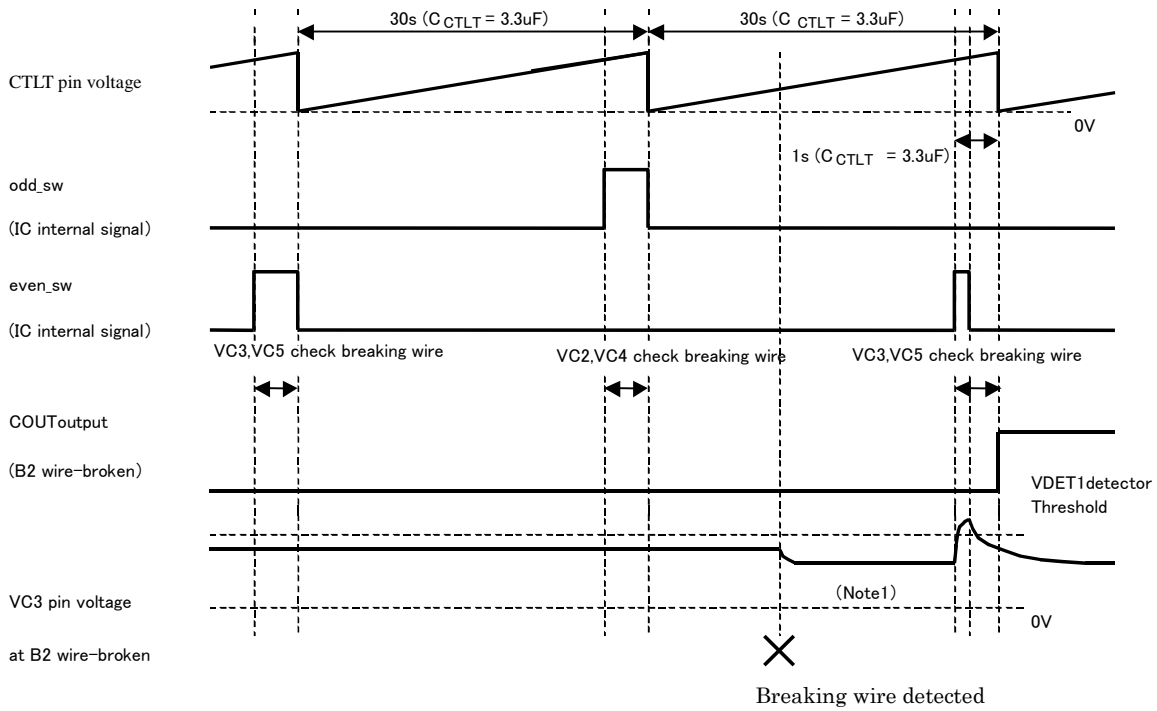

(Note1) The change of VC is not always increasing. Depending on the cell balance or the internal impedance, the VC increases or decreases.

# TYPICAL APPLICATION AND TECHNICAL NOTES

\*Circuit example (R5433VxxxAA)

5-cell protection

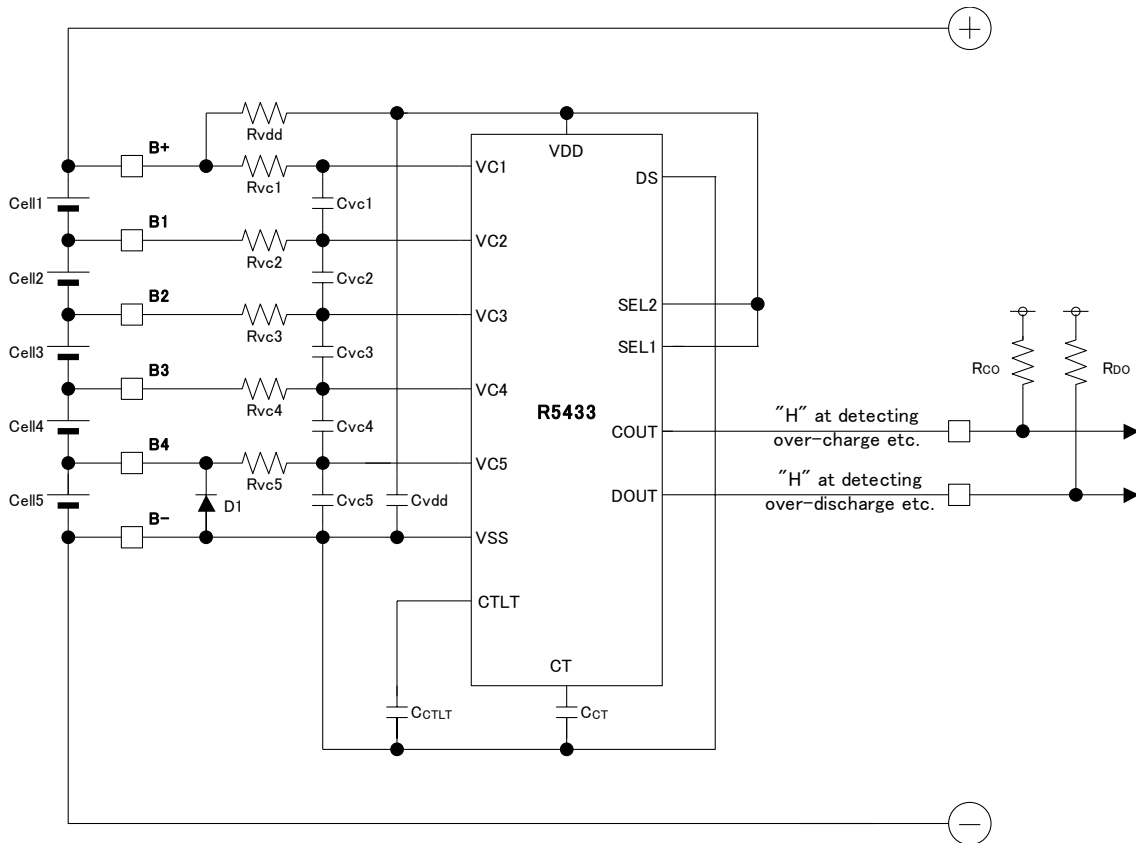

# R5433V

## R5433VxxxAA

\*Circuit example (for 4-cell protection)

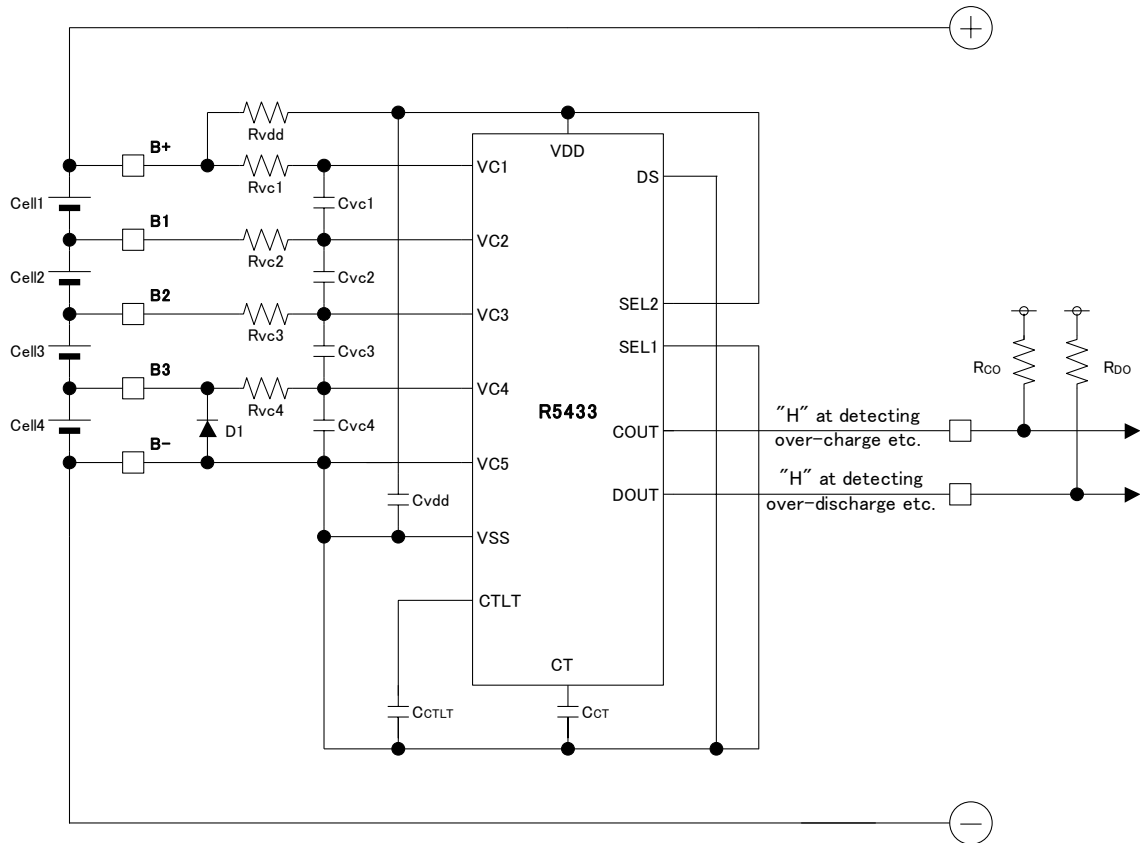

R5433VxxxAA

\*Circuit example (for 3-cell protection)

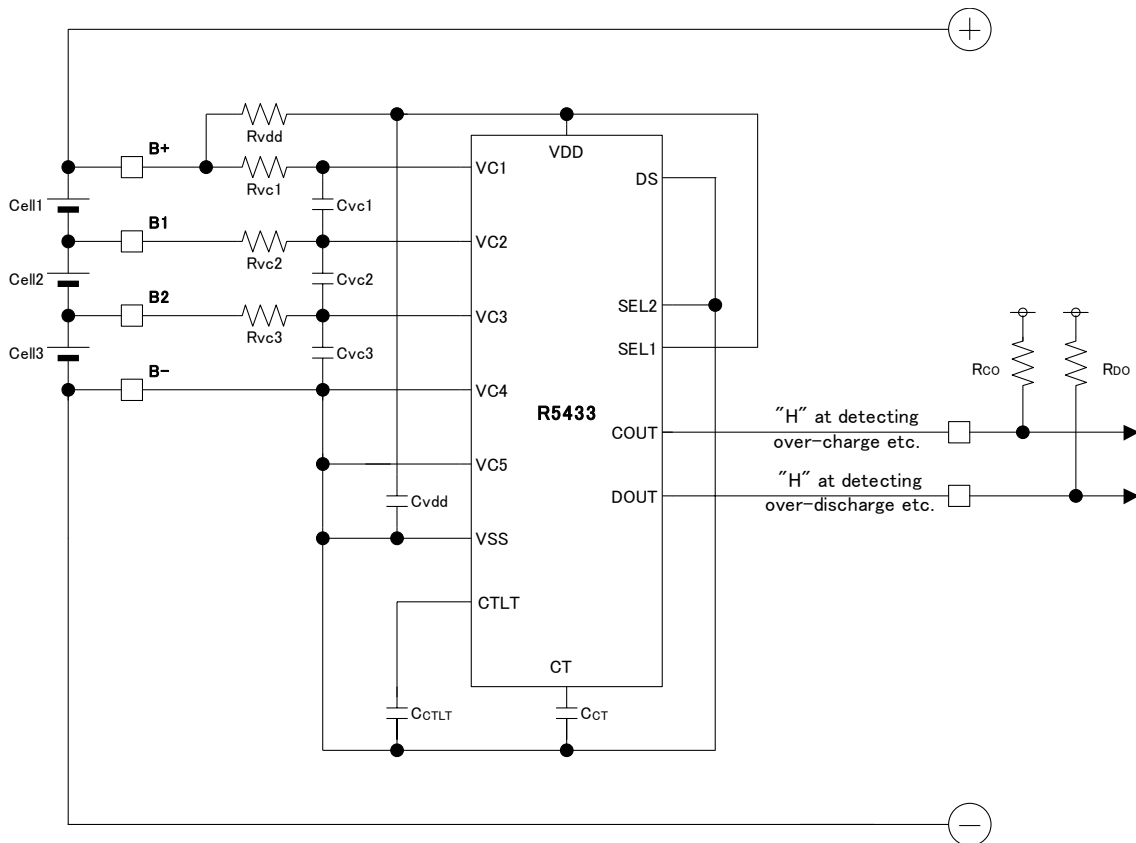

R5433VxxxAB

\* Circuit Example (for 5-cell protection)

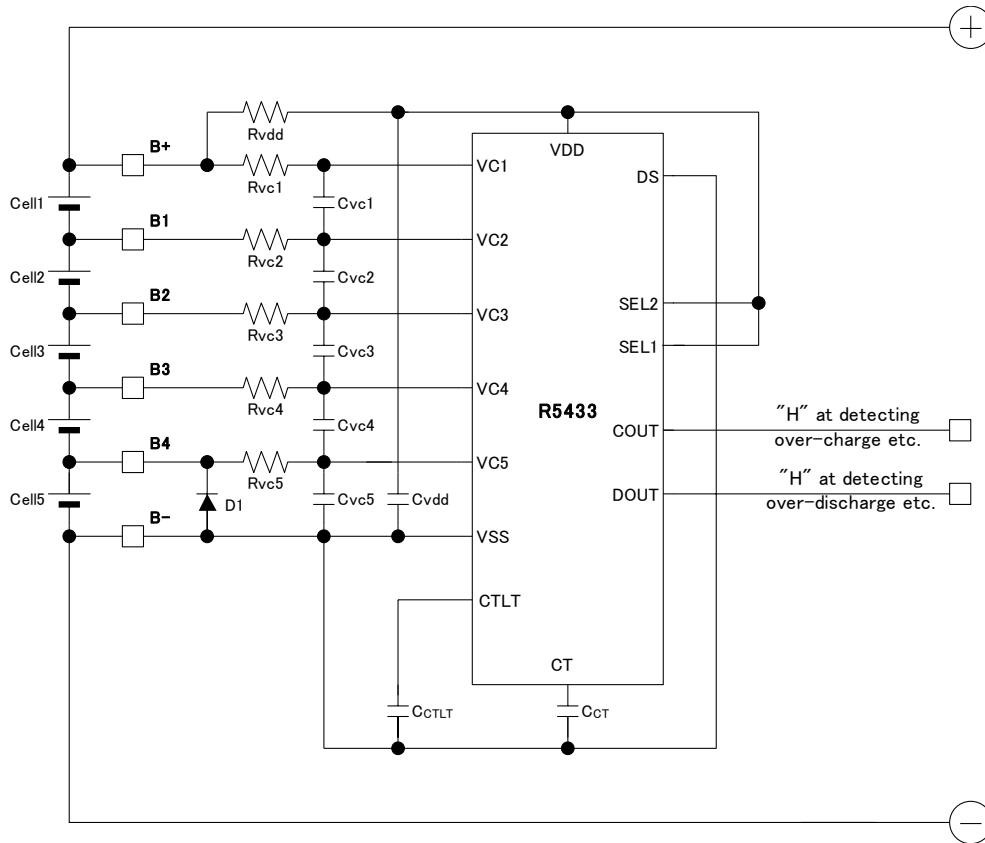

R5433VxxxAB

\* Circuit Example (for 4-cell protection)

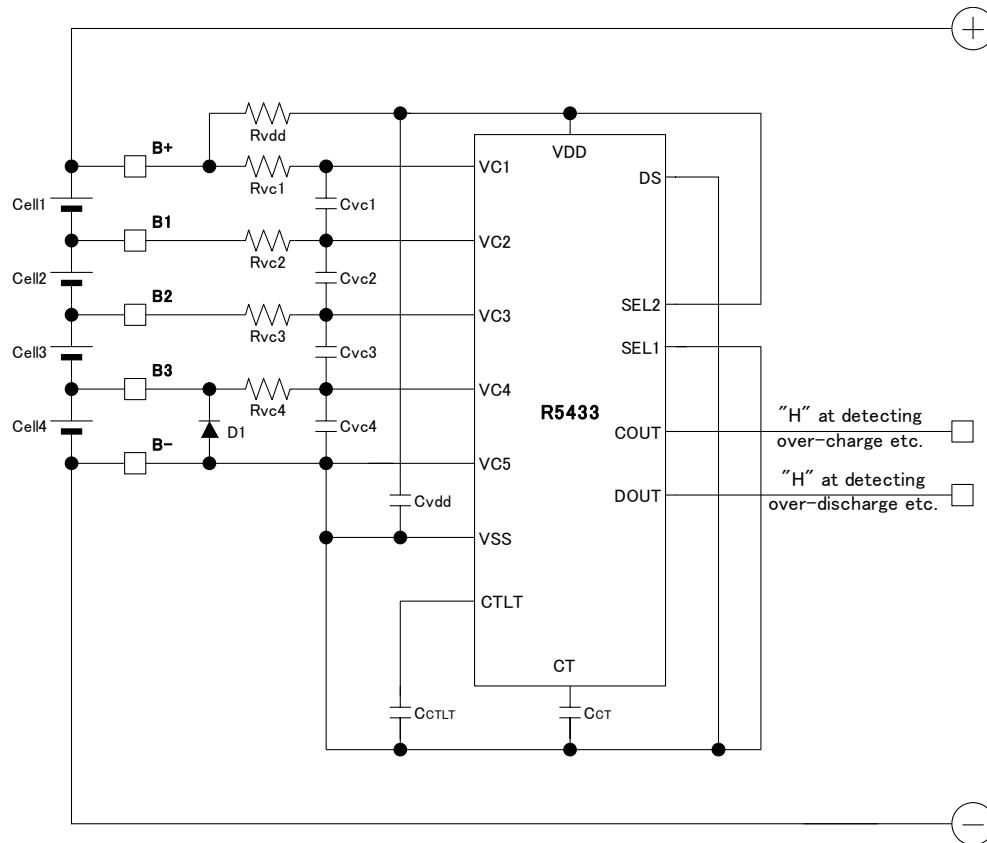

---

# R5433V

---

## R5433VxxxAB

### \* Circuit Example (for 3-cell protection)

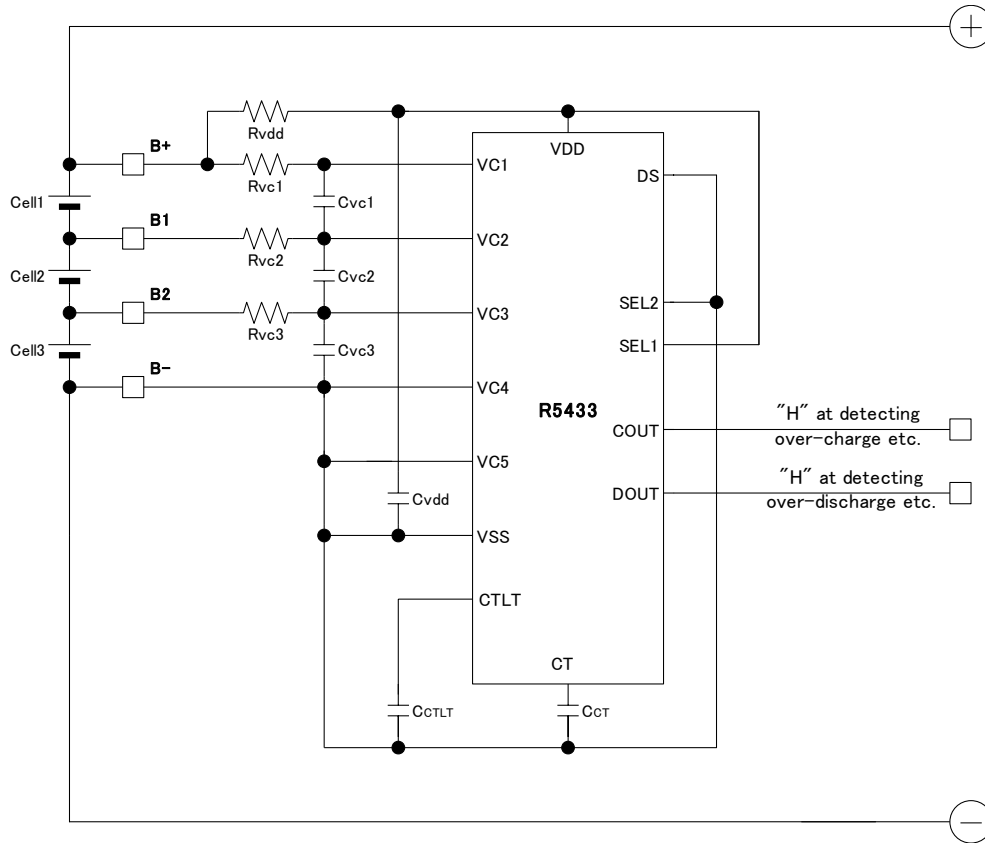



## External Components values

Symbol	Value	Unit	Estimated Range	Reference Technical Notes #
R <sub>VDD</sub>	1000	Ω	510 to 1000	*1
R <sub>VC1</sub>	1000	Ω	1000	*2
R <sub>VC2</sub>	1000	Ω	1000	*2
R <sub>VC3</sub>	1000	Ω	1000	*2
R <sub>VC4</sub>	1000	Ω	1000	*2
R <sub>VC5</sub>	1000	Ω	1000	*2
R <sub>CO</sub>	10	MΩ	*3	*3
R <sub>DO</sub>	10	MΩ	*3	*3
C <sub>VDD</sub>	0.1	μF	0.1 to 1.0	*1
C <sub>VC1</sub>	0.1	μF	0.1	*2
C <sub>VC2</sub>	0.1	μF	0.1	*2
C <sub>VC3</sub>	0.1	μF	0.1	*2
C <sub>VC4</sub>	0.1	μF	0.1	*2
C <sub>VC5</sub>	0.1	μF	0.1	*2
C <sub>CT</sub>	0.33	μF	0.01 to 1.00	*4
C <sub>CTLT</sub>	3.3	μF	3.3	*5
D <sub>1</sub>	*6	*6	*6	*6

## Technical Notes on the external circuits and components

\*1) The voltage fluctuation is stabilized with  $R_{VDD}$  and  $C_{VDD}$ . If a small  $R_{VDD}$  is set, in the case of the large transient may happen to the cell voltage, by the flowing current, the IC may be unstable. If a large  $R_{VDD}$  is set, by the consumption current of the IC itself, the voltage difference between VDD pin and VC1 pin is generated, and unexpected operation may result. Therefore, the appropriate value range of  $R_{VDD}$  is from  $510\Omega$  to  $1k\Omega$ . To make a stable operation of the IC, the appropriate value range of  $C_{VDD}$  is from  $0.1\mu F$  to  $1.0\mu F$ .

\*2)  $R_{VC1}$  to  $R_{VC10}$  and  $C_{VC1}$  to  $C_{VC5}$  stabilize the voltage fluctuation. If large  $R_{VC1}$  to  $R_{VC5}$  is set, the detector threshold will be high because of the internal conduction current of the IC. The operation error of breaking wire detector function may happen easily by the distribution of the ICs or environment. If small  $R_{VC1}$  to  $R_{VC5}$  is set, the noise immunity will be worse. Therefore the appropriate value of  $R_{VC1}$  to  $R_{VC5}$  is  $1k\Omega$ . To make stable operation, use  $0.1\mu F$  as  $C_{VC1}$  to  $C_{VC5}$ .

\*3) If small  $R_{CO}$  or  $R_{DO}$  is set, when the output of  $C_{OUT}$  or  $D_{OUT}$  is "L", the consumption current of protection circuit board increases. If large  $R_{CO}$  or  $R_{DO}$  is set, when the output of  $C_{OUT}$  or  $D_{OUT}$  is "Hi-Z", the speed for pull-down the gate of the charge FET becomes slow and turning off the FET will be slow.

\*4) If the breaking wire detector function of  $V_{C2}$  to  $V_{C5}$  is used, use  $0.33\mu F$  to  $1\mu F$  as  $C_{CT}$ . If the breaking wire detector function is unnecessary, use a capacitor of  $0.01\mu F$  or more.

\*5) If the breaking wire detector of  $V_{C2}$  to  $V_{C5}$  is used, use  $3.3\mu F$  as  $C_{CTLT}$ . If the breaking wire detector of  $V_{C2}$  to  $V_{C5}$  is not necessary, short the  $CTLT$  pin to  $V_{SS}$ .

\*6) If B- wire is broken, the internal regulator voltage may be close to  $V_{DD}$ . In such condition, if B- is reconnected, the over voltage stress is forced to the device connected to the internal regulator, and IC might be damaged. To prevent this situation, connect a diode as in the external components position. Choose the diode with  $V_f$  range is from  $0.55V$  to  $0.8V@25^\circ C$ ,  $1mA$  load.

The typical application circuit diagrams are just examples. This circuit performance largely depends on the PCB layout and external components. In the actual application, fully evaluation is necessary.

Over-voltage and the over current beyond the absolute maximum rating should not be forced to the protection IC and external components.

Ricoh cannot assume responsibility for use of any circuitry other than circuitry entirely embodied in a Ricoh product. If technical notes are not complied with the circuit which is used Ricoh product, Ricoh is not responsible for any damages and any accidents.

# TEST CIRCUITS

M

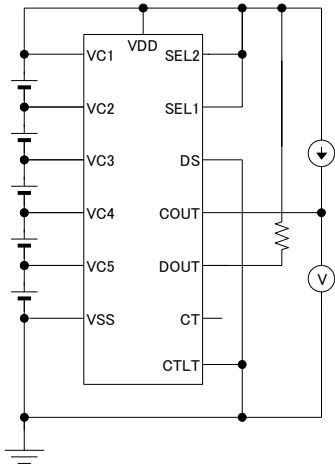

N

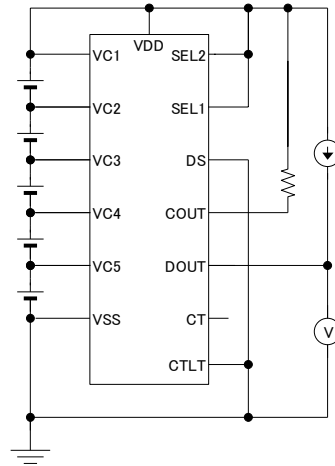

O

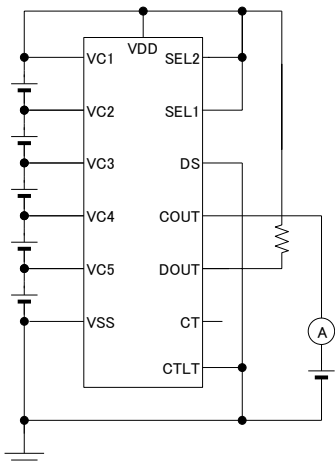

P

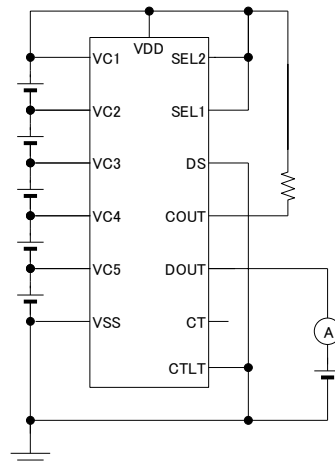

a

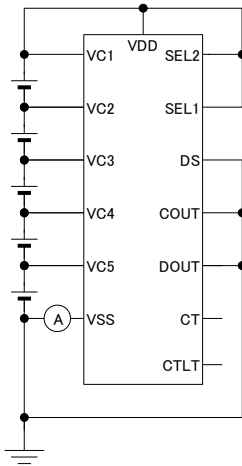

● R5433V<sub>xxx</sub>AB

A

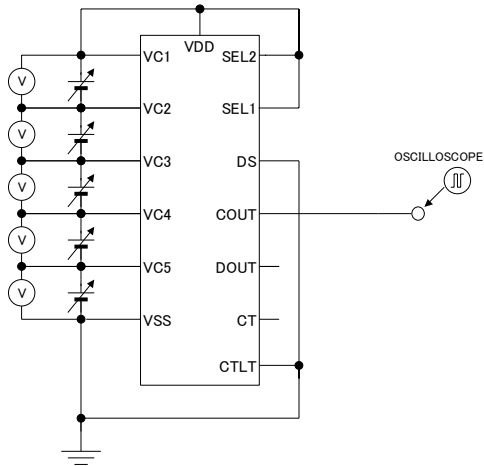

B

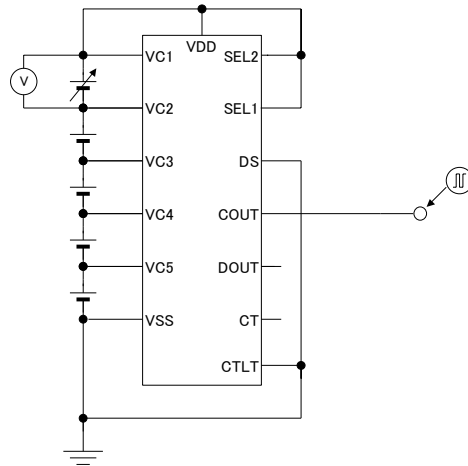

C

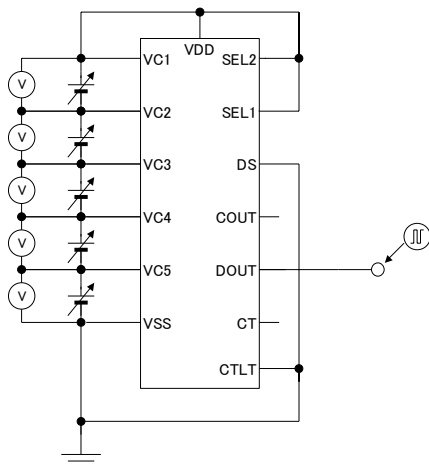

D

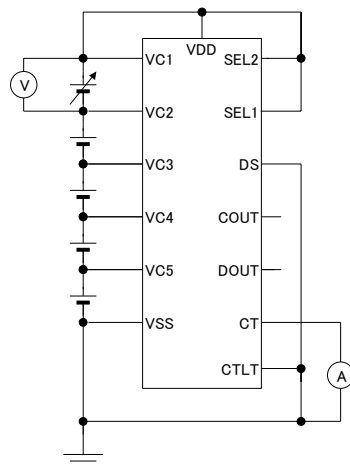

E

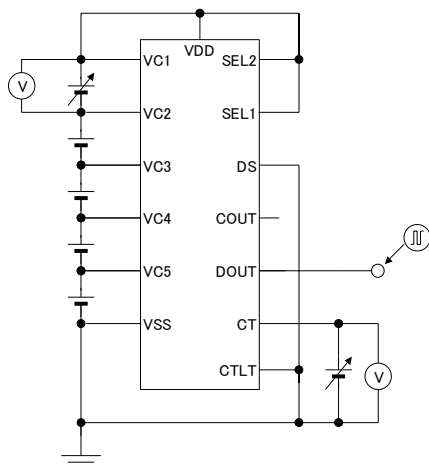

F

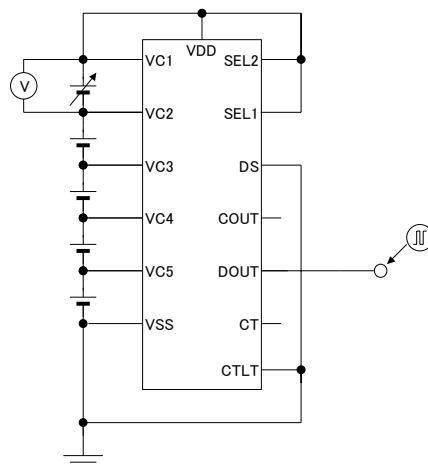

G

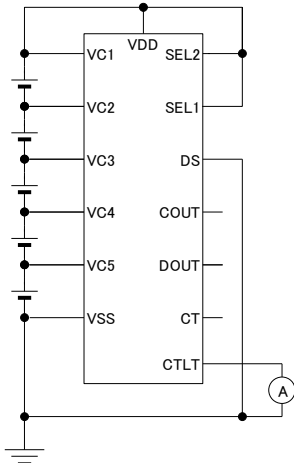

H

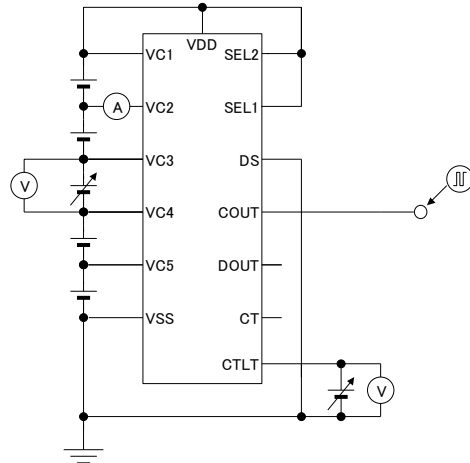

I

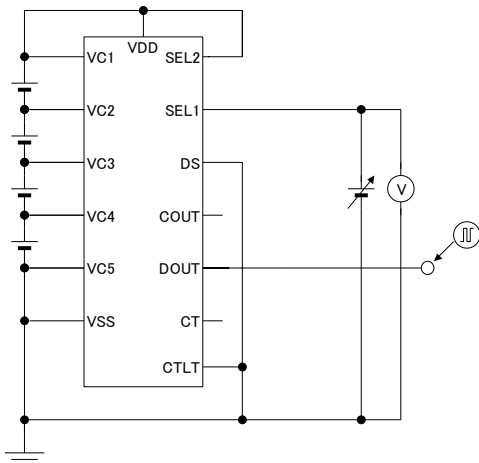

J

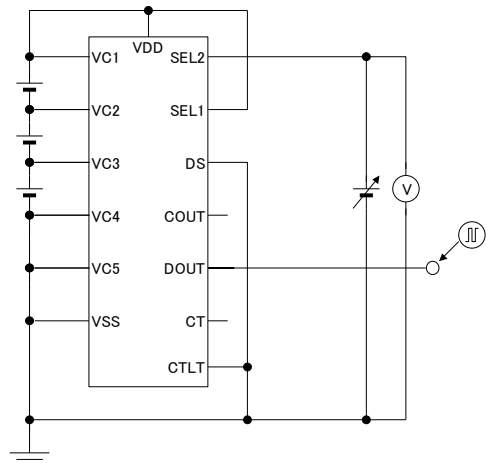

K

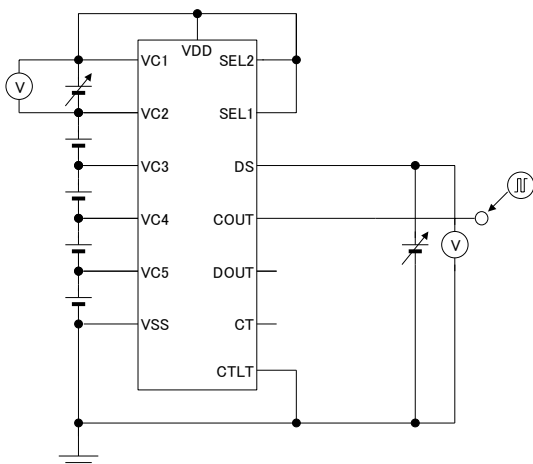

L

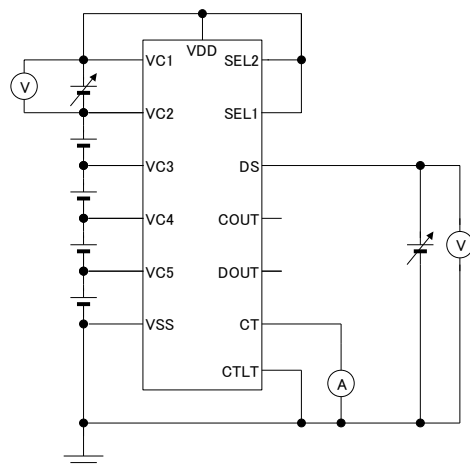

M

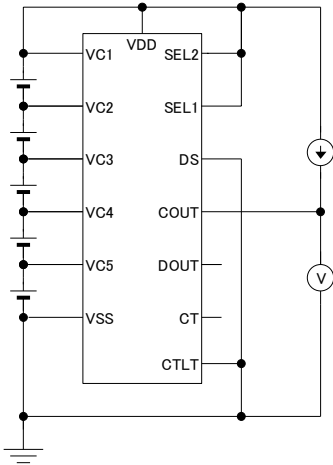

N

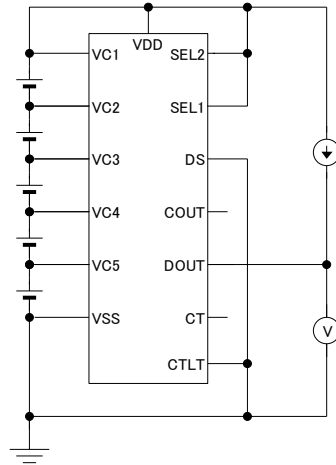

O

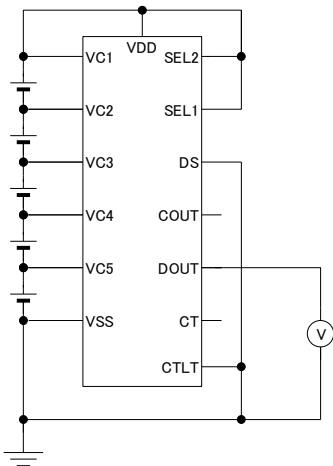

a

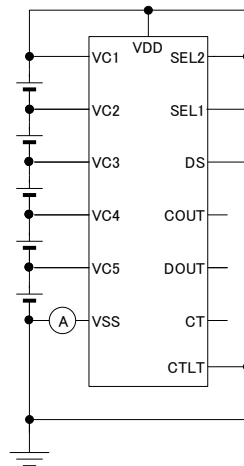

## TYPICAL CHARACTERISTICS

### • Part1. Temperature Characteristics

#### 1) Cell-n Over-charge detector threshold

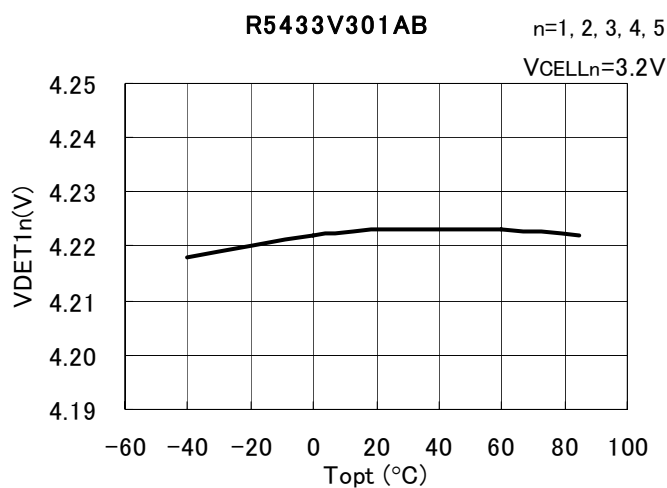

#### 2) Cell-n Over-charge released voltage

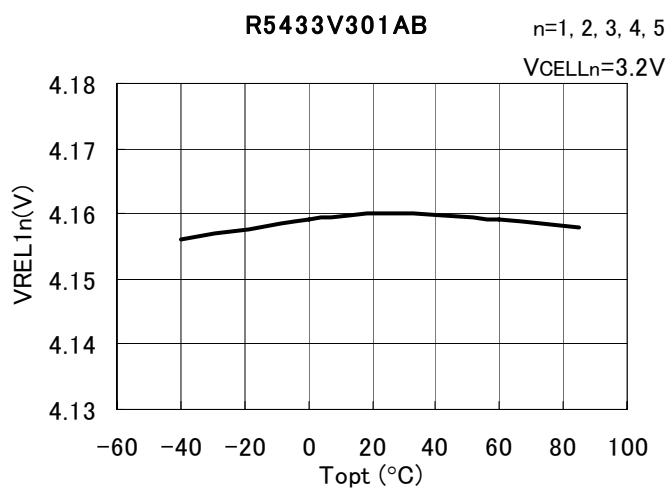

#### 3) Cell-n Output delay time of Over-charge detector

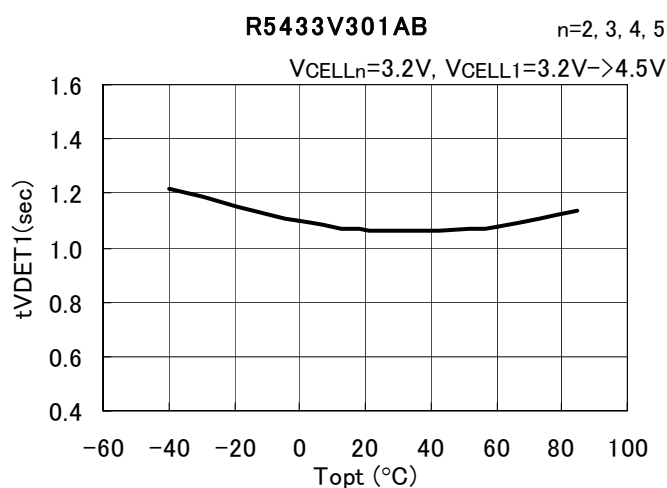

#### 4) Cell-n output delay time for release from over-charge

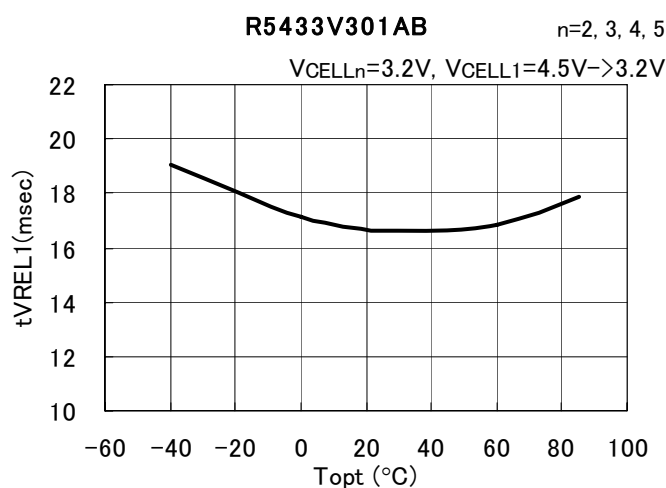

**5) Cell-n over-discharge detector threshold**

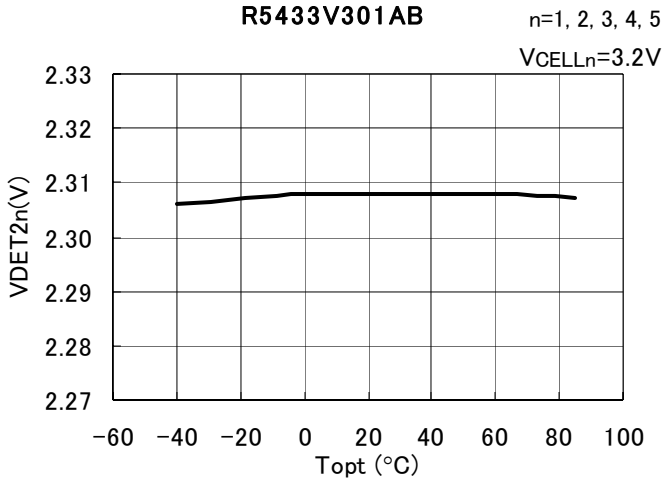

**6) Cell-n released voltage from over-discharge**

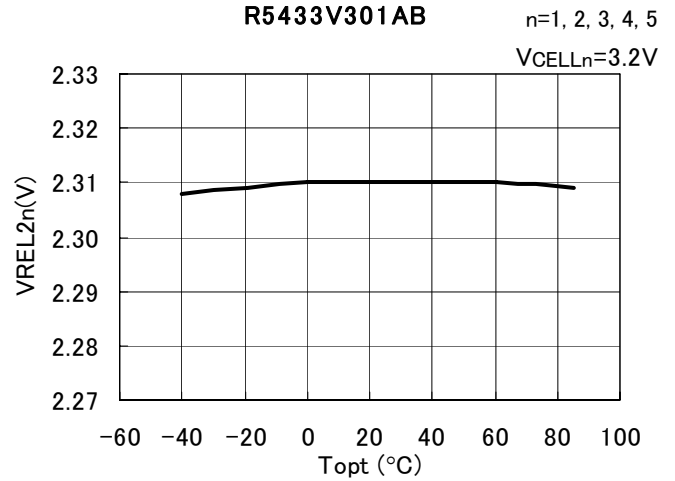

**7) Cell-n over-discharge output delay time**

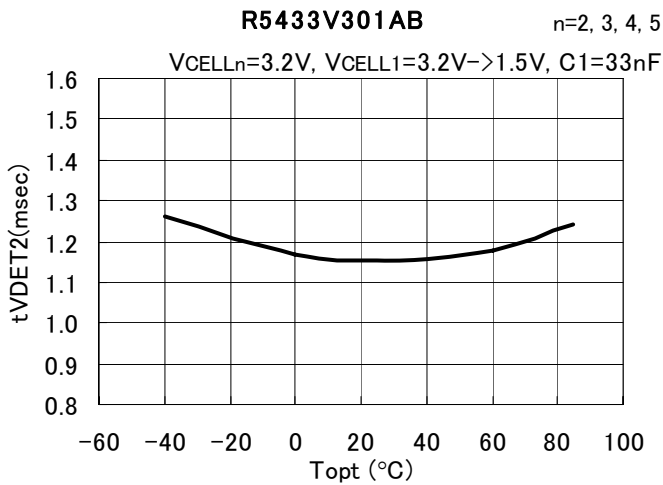

**8) Cell-n over-discharge released delay time**

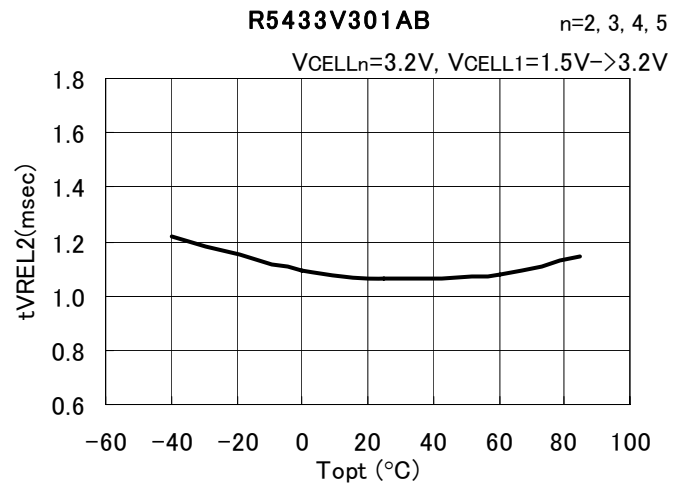

**9) CTLT charge current**

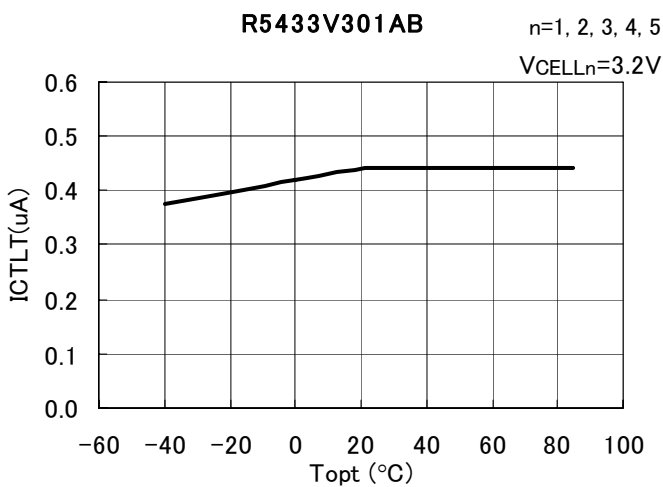

**10) CTLT detector threshold**

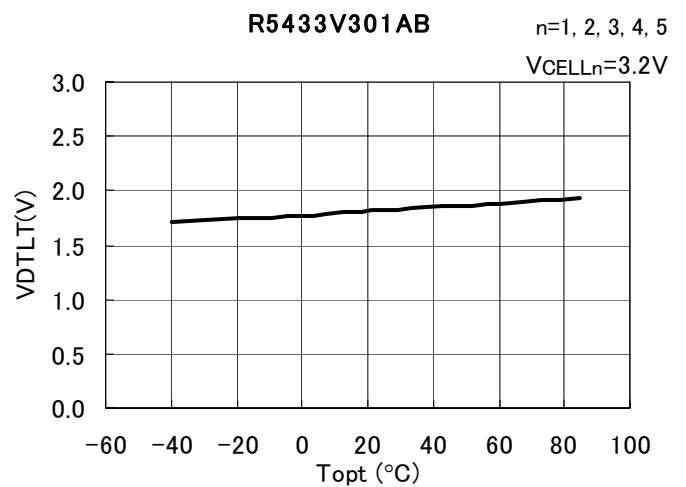



11) CTLT released voltage

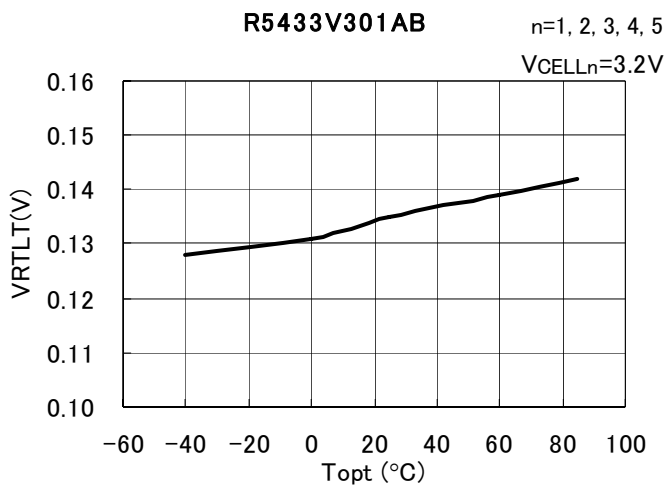

12) Breaking wire test interval time

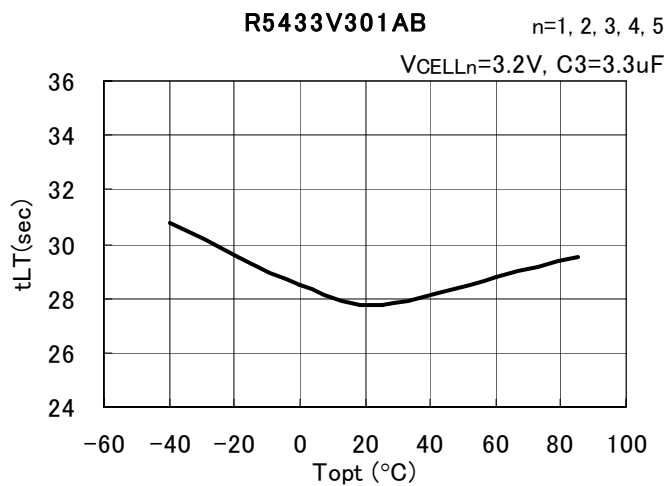

13) C<sub>OUT</sub> N-channel on voltage

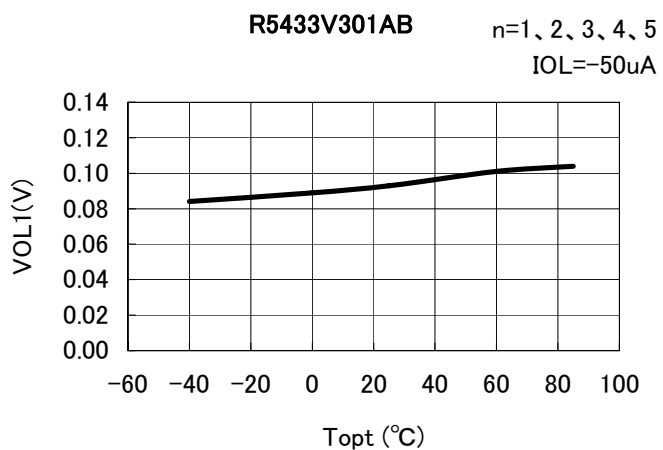

14) C<sub>OUT</sub> P-channel on voltage

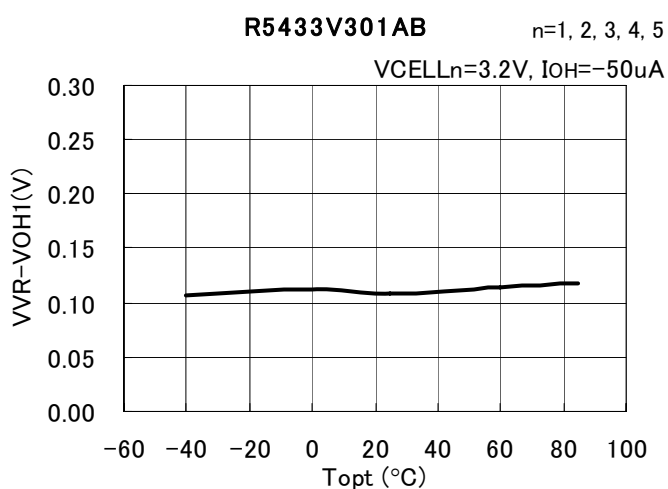

**15) DOUT N-channel on voltage**

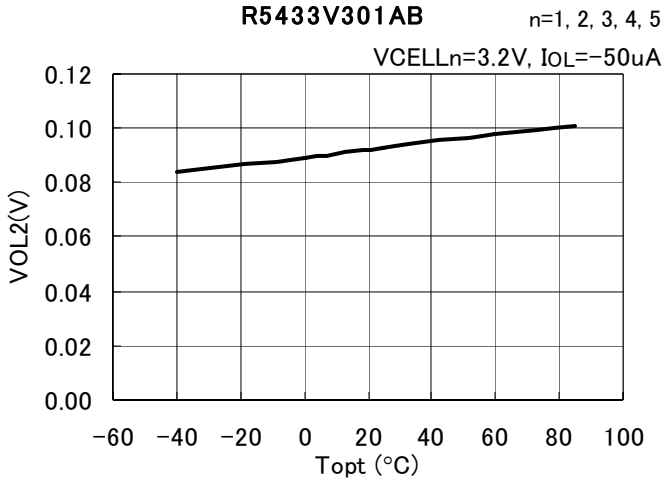

**16) DOUT P-channel on voltage**

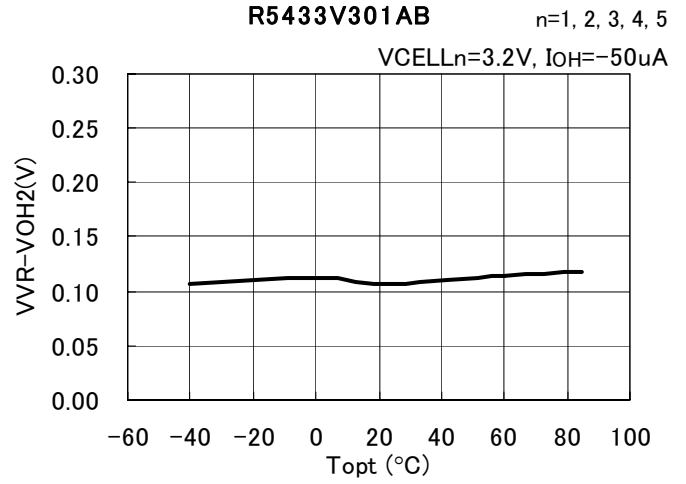

**17) VR V output voltage**

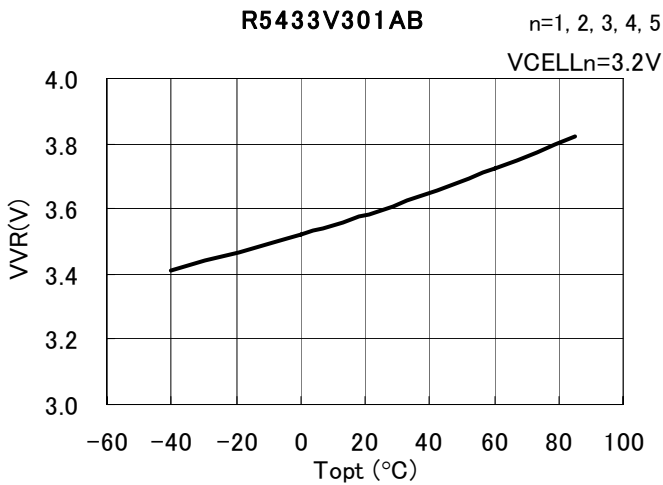

**18) Supply Current 1**

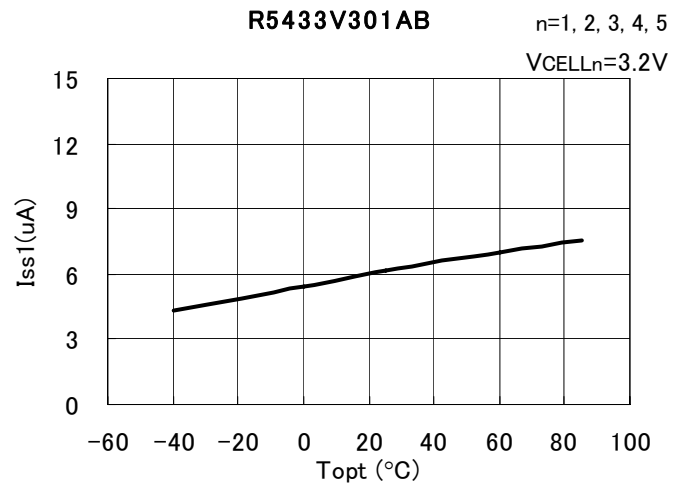

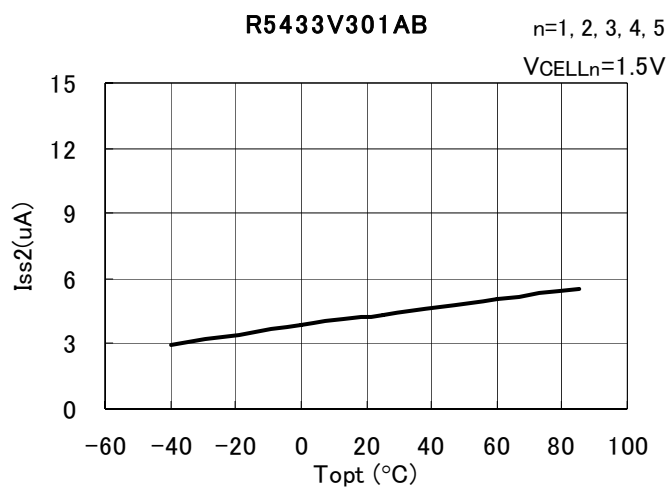
**19) Supply current 2**

• Part 2. Output Delay Time  $V_{DD}$  dependence

Over-charge detector output delay time

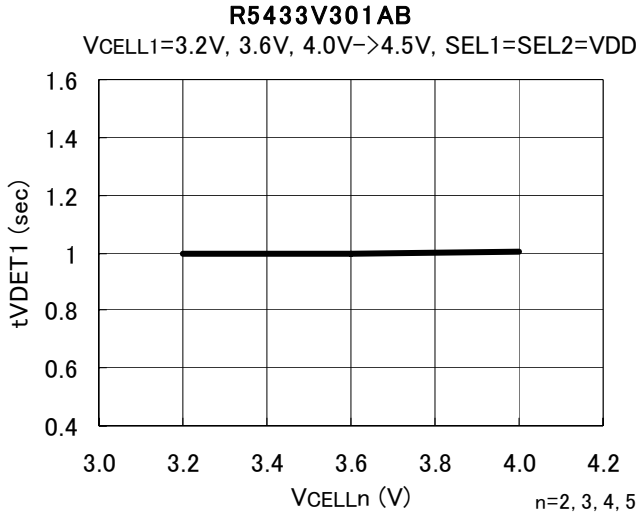

Over-charge released delay time

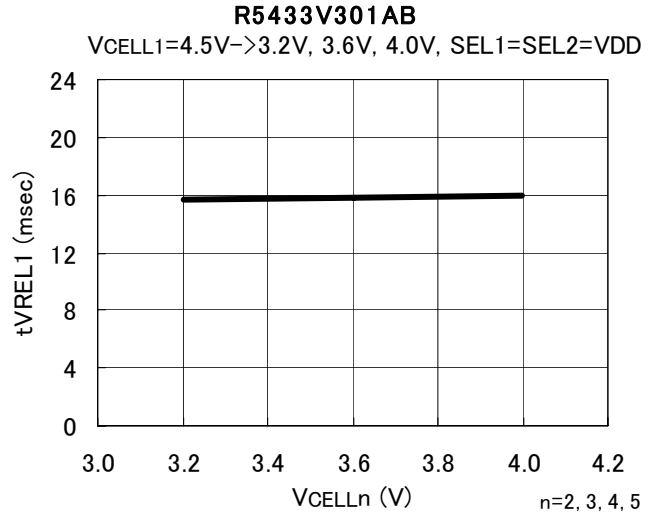

Over-discharge detector output delay time

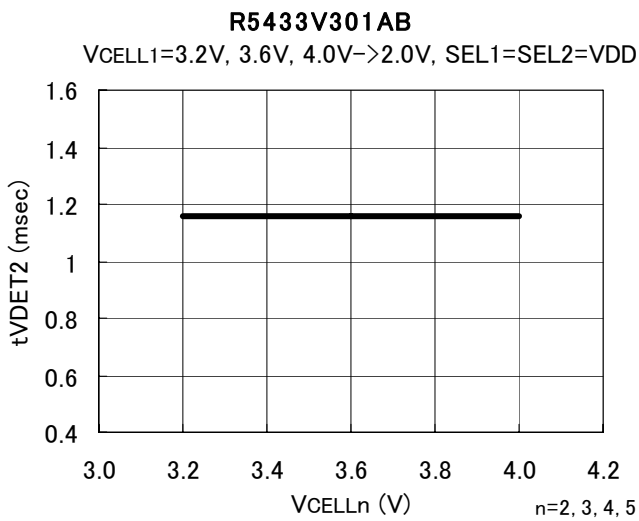

Over-discharge released delay time

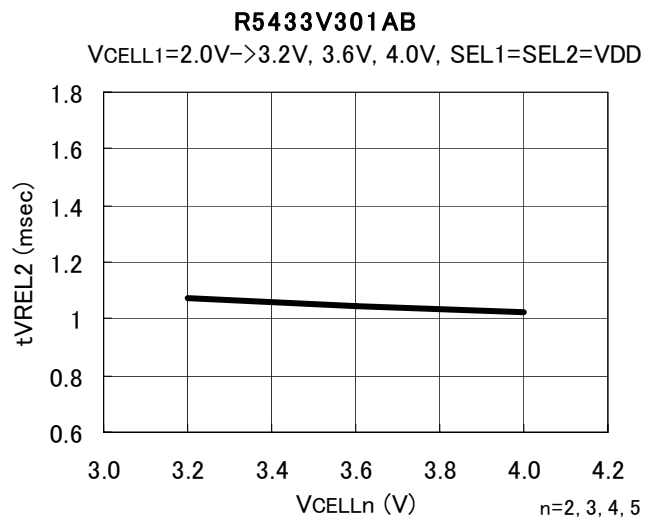

• Part3. Supply current VDD dependence (R5433V301AB)

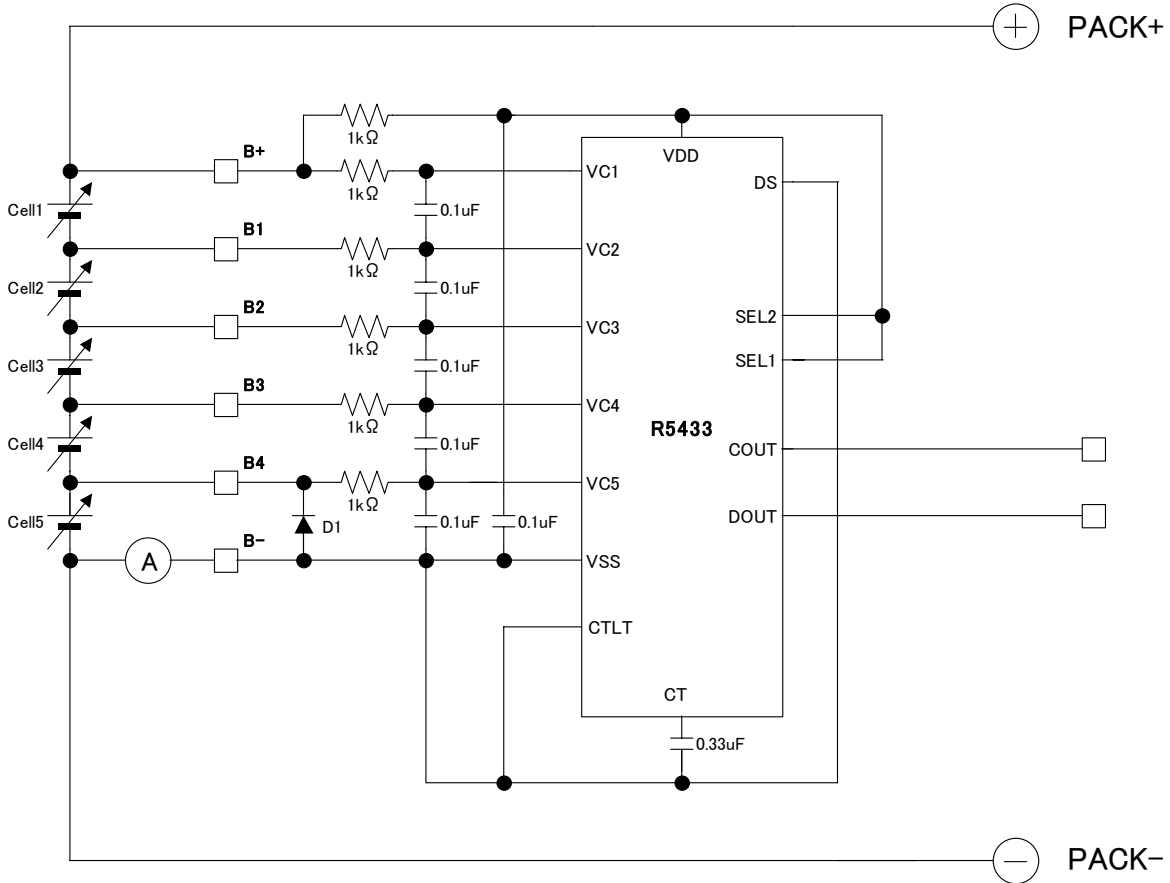

Supply current for 5-cell protection

R5433V301AB

VCELL1=3.2V, 3.6V, 4.0V→2.0V, SEL1=SEL2=VDD

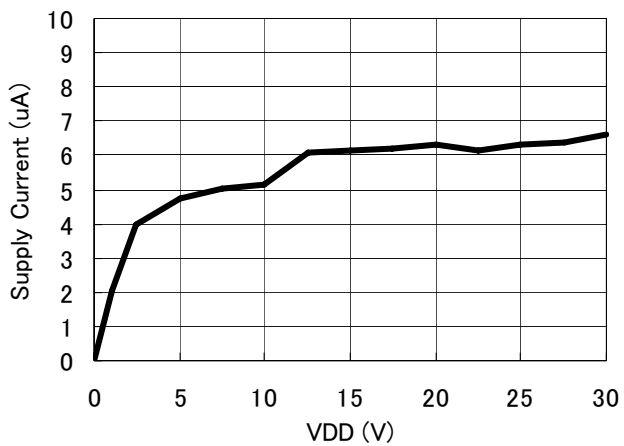

• Part4. External resistance dependence (R5433V301AB)

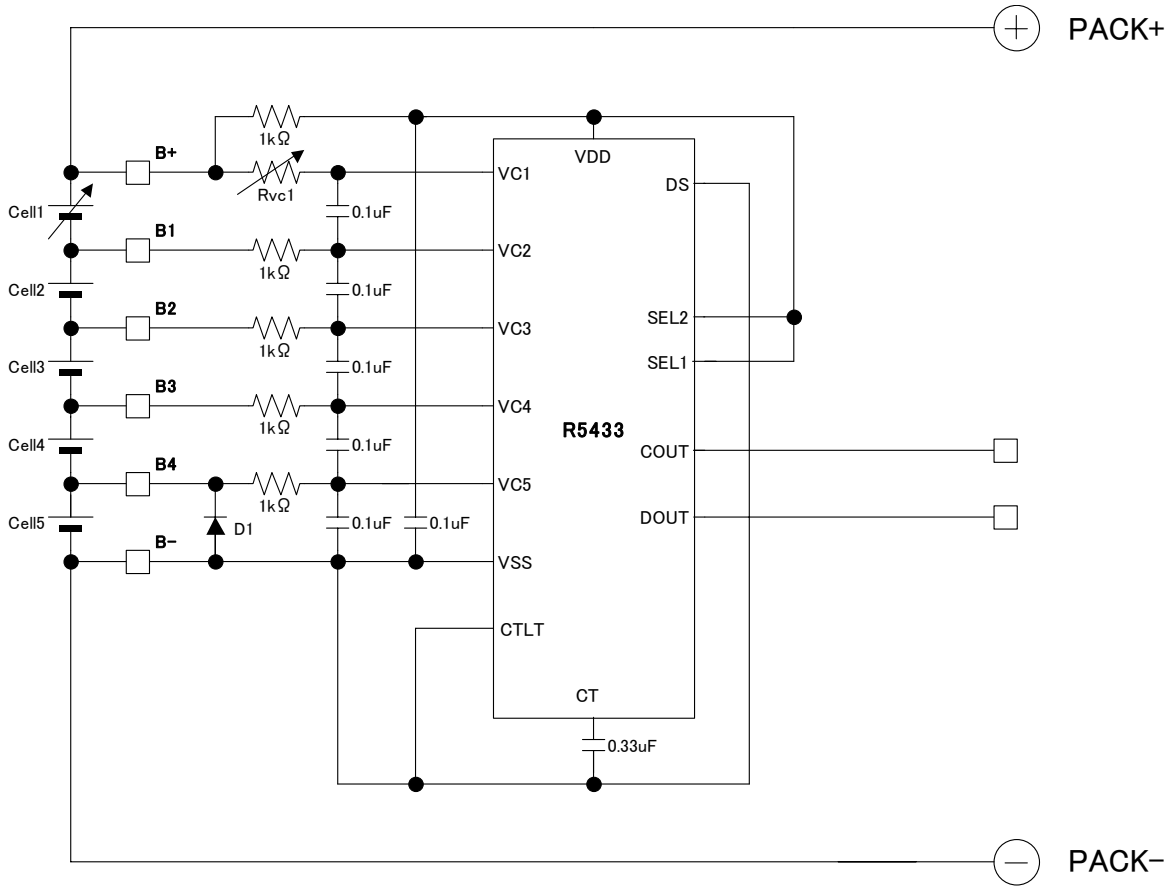

Over-charge/ Released from over-charge vs. R1 (Cell1)

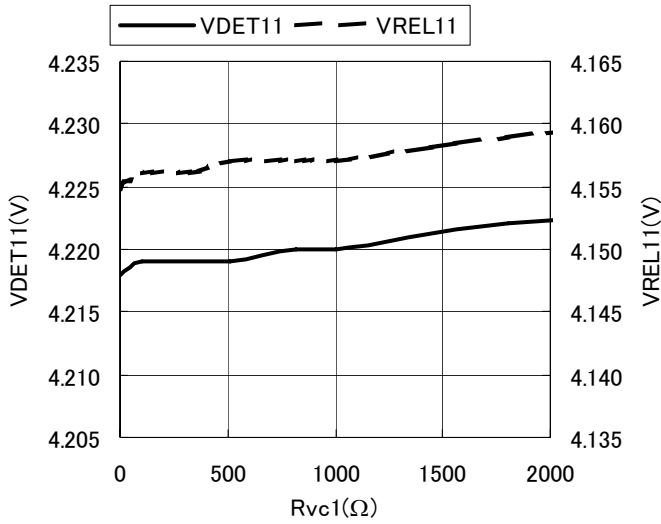

Over-discharge/ Released from over-discharge vs. R1 (Cell1)

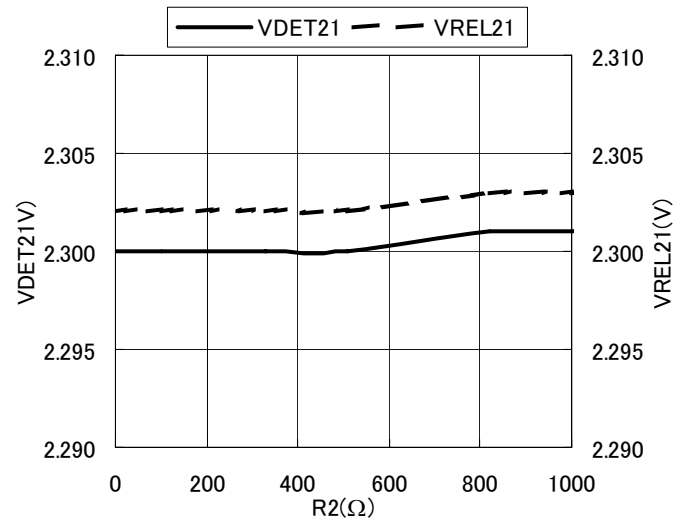

## PACKAGE DIMENSIONS

- SSOP-16P (0.65mm pitch)

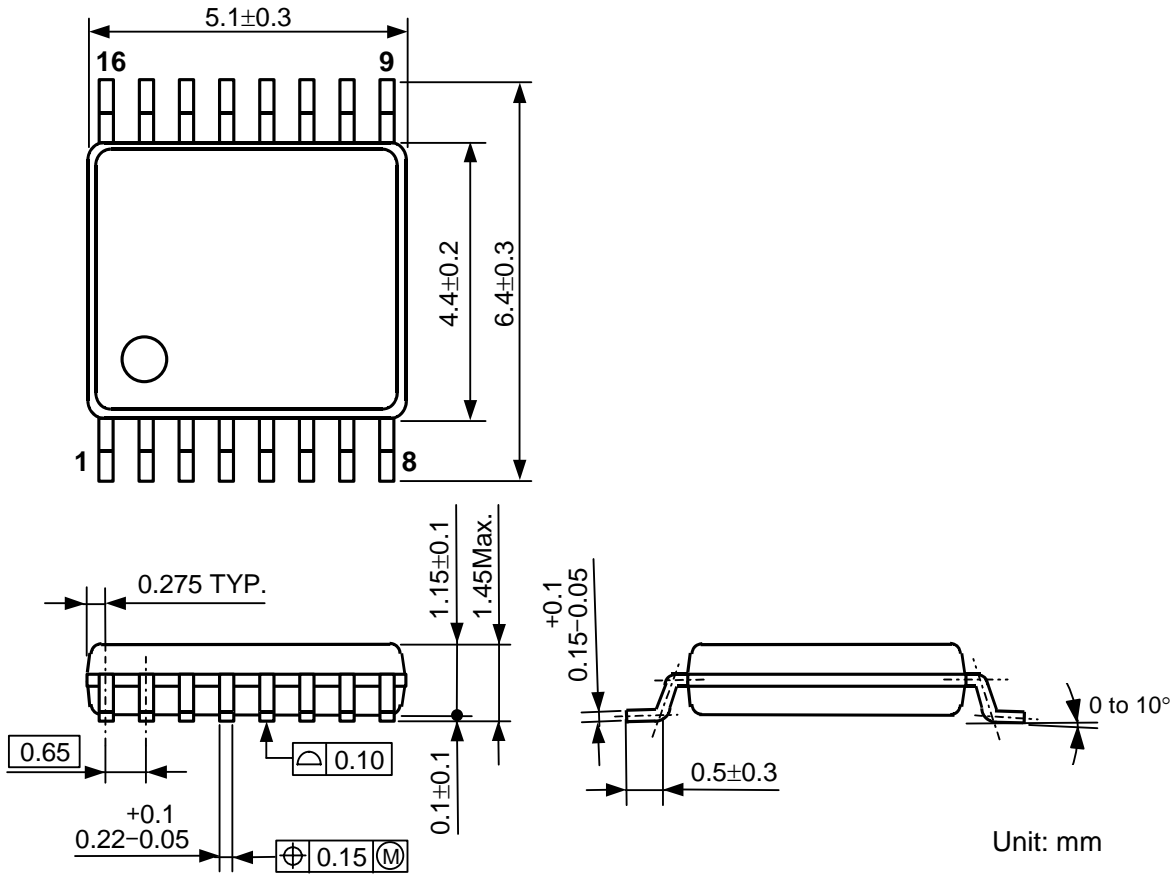





1. The products and the product specifications described in this document are subject to change or discontinuation of production without notice for reasons such as improvement. Therefore, before deciding to use the products, please refer to Ricoh sales representatives for the latest information thereon.
2. The materials in this document may not be copied or otherwise reproduced in whole or in part without prior written consent of Ricoh.
3. Please be sure to take any necessary formalities under relevant laws or regulations before exporting or otherwise taking out of your country the products or the technical information described herein.
4. The technical information described in this document shows typical characteristics of and example application circuits for the products. The release of such information is not to be construed as a warranty of or a grant of license under Ricoh's or any third party's intellectual property rights or any other rights.
5. The products listed in this document are intended and designed for use as general electronic components in standard applications (office equipment, telecommunication equipment, measuring instruments, consumer electronic products, amusement equipment etc.). Those customers intending to use a product in an application requiring extreme quality and reliability, for example, in a highly specific application where the failure or misoperation of the product could result in human injury or death (aircraft, spacevehicle, nuclear reactor control system, traffic control system, automotive and transportation equipment, combustion equipment, safety devices, life support system etc.) should first contact us.
6. We are making our continuous effort to improve the quality and reliability of our products, but semiconductor products are likely to fail with certain probability. In order to prevent any injury to persons or damages to property resulting from such failure, customers should be careful enough to incorporate safety measures in their design, such as redundancy feature, fire containment feature and fail-safe feature. We do not assume any liability or responsibility for any loss or damage arising from misuse or inappropriate use of the products.
7. Anti-radiation design is not implemented in the products described in this document.
8. The X-ray exposure can influence functions and characteristics of the products. Confirm the product functions and characteristics in the evaluation stage.
9. WLCSP products should be used in light shielded environments. The light exposure can influence functions and characteristics of the products under operation or storage.
10. There can be variation in the marking when different AOI (Automated Optical Inspection) equipment is used. In the case of recognizing the marking characteristic with AOI, please contact Ricoh sales or our distributor before attempting to use AOI.
11. Please contact Ricoh sales representatives should you have any questions or comments concerning the products or the technical information.



**Ricoh is committed to reducing the environmental loading materials in electrical devices with a view to contributing to the protection of human health and the environment.**

Ricoh has been providing RoHS compliant products since April 1, 2006 and Halogen-free products since April 1, 2012.

**RICOH** RICOH ELECTRONIC DEVICES CO., LTD.

<https://www.e-devices.ricoh.co.jp/en/>

#### Sales & Support Offices

##### **Ricoh Electronic Devices Co., Ltd.**

##### **Shin-Yokohama Office (International Sales)**

2-3, Shin-Yokohama 3-chome, Kohoku-ku, Yokohama-shi, Kanagawa, 222-8530, Japan  
Phone: +81-50-3814-7687 Fax: +81-45-474-0074

##### **Ricoh Americas Holdings, Inc.**

675 Campbell Technology Parkway, Suite 200 Campbell, CA 95008, U.S.A.  
Phone: +1-408-610-3105

##### **Ricoh Europe (Netherlands) B.V.**

##### **Semiconductor Support Centre**

Prof. W.H. Keesomlaan 1, 1183 DJ Amstelveen, The Netherlands  
Phone: +31-20-5474-309

##### **Ricoh International B.V. - German Branch**

##### **Semiconductor Sales and Support Centre**

Oberrather Strasse 6, 40472 Düsseldorf, Germany  
Phone: +49-211-6546-0

##### **Ricoh Electronic Devices Korea Co., Ltd.**

3F, Haesung Bldg, 504, Teheran-ro, Gangnam-gu, Seoul, 135-725, Korea  
Phone: +82-2-2135-5700 Fax: +82-2-2051-5713

##### **Ricoh Electronic Devices Shanghai Co., Ltd.**

Room 403, No.2 Building, No.690 Bibo Road, Pu Dong New District, Shanghai 201203,  
People's Republic of China  
Phone: +86-21-5027-3200 Fax: +86-21-5027-3299

##### **Ricoh Electronic Devices Shanghai Co., Ltd.**

##### **Shenzhen Branch**

1205, Block D (Jinlong Building), Kingkey 100, Hongbao Road, Luohu District,  
Shenzhen, China  
Phone: +86-755-8348-7600 Ext 225

##### **Ricoh Electronic Devices Co., Ltd.**

##### **Taipei office**

Room 109, 10F-1, No.51, Hengyang Rd., Taipei City, Taiwan  
Phone: +886-2-2313-1621/1622 Fax: +886-2-2313-1623

# Mouser Electronics

Authorized Distributor

Click to View Pricing, Inventory, Delivery & Lifecycle Information:

[Ricoch Electronics:](#)

[R5433V302AB-E2-FE](#) [R5433V403AA-E2-FE](#)

Компания «Life Electronics» занимается поставками электронных компонентов импортного и отечественного производства от производителей и со складов крупных дистрибьюторов Европы, Америки и Азии.

С конца 2013 года компания активно расширяет линейку поставок компонентов по направлению коаксиальный кабель, кварцевые генераторы и конденсаторы (керамические, пленочные, электролитические), за счёт заключения дистрибьюторских договоров

Мы предлагаем:

- Конкурентоспособные цены и скидки постоянным клиентам.
- Специальные условия для постоянных клиентов.
- Подбор аналогов.
- Поставку компонентов в любых объемах, удовлетворяющих вашим потребностям.
- Приемлемые сроки поставки, возможна ускоренная поставка.
- Доставку товара в любую точку России и стран СНГ.
- Комплексную поставку.
- Работу по проектам и поставку образцов.
- Формирование склада под заказчика.
- Сертификаты соответствия на поставляемую продукцию (по желанию клиента).
- Тестирование поставляемой продукции.
- Поставку компонентов, требующих военную и космическую приемку.
- Входной контроль качества.
- Наличие сертификата ISO.

В составе нашей компании организован Конструкторский отдел, призванный помогать разработчикам, и инженерам.

Конструкторский отдел помогает осуществить:

- Регистрацию проекта у производителя компонентов.
- Техническую поддержку проекта.
- Защиту от снятия компонента с производства.
- Оценку стоимости проекта по компонентам.
- Изготовление тестовой платы монтаж и пусконаладочные работы.



Тел: +7 (812) 336 43 04 (многоканальный)  
Email: [org@lifeelectronics.ru](mailto:org@lifeelectronics.ru)