

**ISOTOP[®] Buck chopper
Trench + Field Stop IGBT[®]**

**$V_{CES} = 1200V$
 $I_C = 75A @ T_c = 80^{\circ}C$**

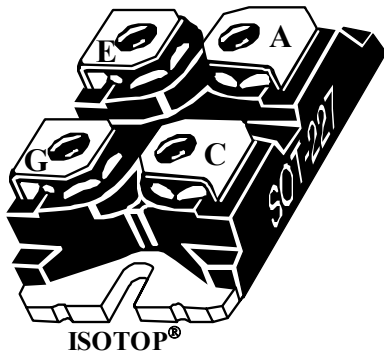
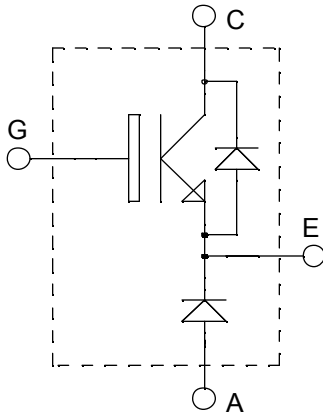

Application

- AC and DC motor control
- Switched Mode Power Supplies

Features

- Trench + Field Stop IGBT[®] Technology
 - Low voltage drop
 - Low tail current
 - Switching frequency up to 20 kHz
 - Soft recovery parallel diodes
 - Low diode VF
 - Low leakage current
 - Avalanche energy rated
 - RBSOA and SCSOA rated
- ISOTOP[®] Package (SOT-227)
- Very low stray inductance
- High level of integration

Benefits

- Low conduction losses
- Stable temperature behavior
- Very rugged
- Direct mounting to heatsink (isolated package)
- Low junction to case thermal resistance
- Easy paralleling due to positive T_C of V_{CESat}
- RoHS Compliant

Absolute maximum ratings

| Symbol | Parameter | Max ratings | Unit |
|------------|---|---------------------|------|
| V_{CES} | Collector - Emitter Breakdown Voltage | 1200 | V |
| I_{C1} | Continuous Collector Current | $T_C = 25^{\circ}C$ | A |
| I_{C2} | | $T_C = 80^{\circ}C$ | |
| I_{CM} | Pulsed Collector Current | $T_C = 25^{\circ}C$ | 175 |
| V_{GE} | Gate - Emitter Voltage | ± 20 | V |
| P_D | Maximum Power Dissipation | $T_C = 25^{\circ}C$ | 416 |
| I_{FAV} | Maximum Average Forward Current | $T_C = 80^{\circ}C$ | A |
| I_{FRMS} | RMS Forward Current (Square wave, 50% duty) | | |
| | | | 34 |

 **CAUTION:** These Devices are sensitive to Electrostatic Discharge. Proper Handling Procedures Should Be Followed.

All ratings @ $T_j = 25^\circ\text{C}$ unless otherwise specified

Electrical Characteristics

| <i>Symbol</i> | <i>Characteristic</i> | <i>Test Conditions</i> | <i>Min</i> | <i>Typ</i> | <i>Max</i> | <i>Unit</i> |
|---------------|-------------------------------------|---|----------------------------------|------------|------------|-------------|
| I_{CES} | Zero Gate Voltage Collector Current | $V_{GE} = 0\text{V}, V_{CE} = 1200\text{V}$ | | | 5 | mA |
| $V_{CE(on)}$ | Collector Emitter on Voltage | $V_{GE} = 15\text{V}$ $I_C = 75\text{A}$ | $T_j = 25^\circ\text{C}$ 1.4 | 1.7 | 2.1 | V |
| | | | $T_j = 125^\circ\text{C}$ 2.0 | | | |
| $V_{GE(th)}$ | Gate Threshold Voltage | $V_{GE} = V_{CE}, I_C = 3\text{mA}$ | 5.0 | | 6.5 | V |
| I_{GES} | Gate – Emitter Leakage Current | $V_{GE} = \pm 20\text{V}, V_{CE} = 0\text{V}$ | | | 500 | nA |

Dynamic Characteristics

| <i>Symbol</i> | <i>Characteristic</i> | <i>Test Conditions</i> | <i>Min</i> | <i>Typ</i> | <i>Max</i> | <i>Unit</i> |
|---------------|------------------------------|--|------------|------------|------------|-------------|
| C_{ies} | Input Capacitance | $V_{GE} = 0\text{V}$ | | 5340 | | pF |
| C_{oes} | Output Capacitance | $V_{CE} = 25\text{V}$ | | 280 | | |
| C_{res} | Reverse Transfer Capacitance | $f = 1\text{MHz}$ | | 240 | | |
| $T_{d(on)}$ | Turn-on Delay Time | Resistive Switching (25°C) | | 260 | | ns |
| T_r | Rise Time | $V_{GE} = 15\text{V}$ $V_{Bus} = 600\text{V}$ | | 30 | | |
| $T_{d(off)}$ | Turn-off Delay Time | $I_C = 75\text{A}$ | | 420 | | |
| T_f | Fall Time | $R_G = 4.7\Omega$ | | 70 | | |
| $T_{d(on)}$ | Turn-on Delay Time | Inductive Switching (125°C) | | 290 | | ns |
| T_r | Rise Time | $V_{GE} = 15\text{V}$ $V_{Bus} = 600\text{V}$ | | 45 | | |
| $T_{d(off)}$ | Turn-off Delay Time | $I_C = 75\text{A}$ | | 520 | | |
| T_f | Fall Time | $R_G = 4.7\Omega$ | | 90 | | |
| E_{on} | Turn-on Switching Energy | | | 7 | | mJ |
| E_{off} | Turn-off Switching Energy | | | 9.5 | | |

Chopper diode ratings and characteristics

| Symbol | Characteristic | Test Conditions | Min | Typ | Max | Unit |
|-----------|----------------------------------|---|---------------------|------|-----|---------|
| V_F | Diode Forward Voltage | $I_F = 30A$ | | 2.0 | 2.5 | V |
| | | $I_F = 60A$ | | 2.3 | | |
| | | $I_F = 30A$ | $T_j = 125^\circ C$ | 1.8 | | |
| I_{RM} | Maximum Reverse Leakage Current | $V_R = 1200V$ | $T_j = 25^\circ C$ | | 250 | μA |
| | | $V_R = 1200V$ | $T_j = 125^\circ C$ | | 500 | |
| C_T | Junction Capacitance | $V_R = 200V$ | | 32 | | pF |
| t_{rr} | Reverse Recovery Time | $I_F = 1A, V_R = 30V$ $di/dt = 100A/\mu s$ | $T_j = 25^\circ C$ | 31 | | ns |
| | Reverse Recovery Time | | $T_j = 25^\circ C$ | 370 | | |
| | | | $T_j = 125^\circ C$ | 500 | | |
| I_{RRM} | Maximum Reverse Recovery Current | $I_F = 30A$ $V_R = 800V$ $di/dt = 200A/\mu s$ | $T_j = 25^\circ C$ | 5 | | A |
| | | | $T_j = 125^\circ C$ | 12 | | |
| | | | $T_j = 25^\circ C$ | 660 | | |
| Q_{rr} | Reverse Recovery Charge | | $T_j = 25^\circ C$ | 3450 | | nC |
| | | | $T_j = 125^\circ C$ | | | |
| t_{rr} | Reverse Recovery Time | $I_F = 30A$ | $T_j = 125^\circ C$ | 220 | | ns |
| Q_{rr} | Reverse Recovery Charge | $V_R = 800V$ | | 4650 | | nC |
| I_{RRM} | Maximum Reverse Recovery Current | $di/dt = 1000A/\mu s$ | | 37 | | A |

Thermal and package characteristics

| Symbol | Characteristic | Min | Typ | Max | Unit |
|----------------|---|-------|------|-----|--------------|
| R_{thJC} | Junction to Case Thermal Resistance | IGBT | | 0.3 | $^\circ C/W$ |
| | | Diode | | 1.1 | |
| R_{thJA} | Junction to Ambient (IGBT & Diode) | | | 20 | |
| V_{ISOL} | RMS Isolation Voltage, any terminal to case $t = 1$ min, $I_{isol} < 1mA$, 50/60Hz | 2500 | | | V |
| T_j, T_{STG} | Storage Temperature Range | -55 | | 150 | $^\circ C$ |
| T_L | Max Lead Temp for Soldering: 0.063" from case for 10 sec | | | 300 | |
| Torque | Mounting torque (Mounting = 8-32 or 4mm Machine and terminals = 4mm Machine) | | | 1.5 | N.m |
| Wt | Package Weight | | 29.2 | | g |

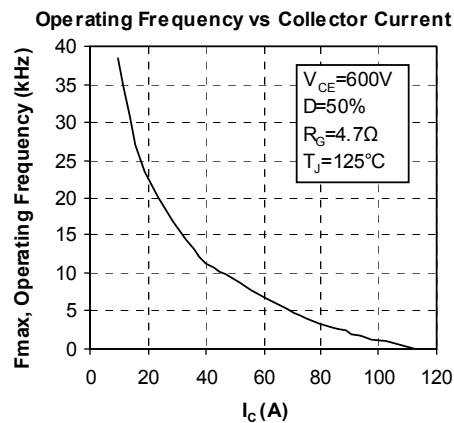
Typical IGBT Performance Curve

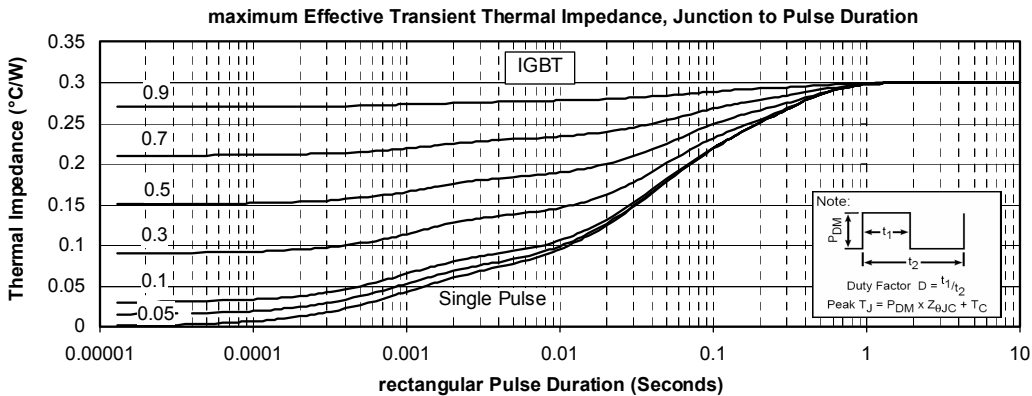
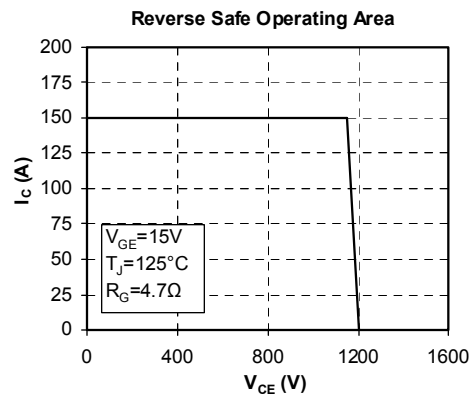
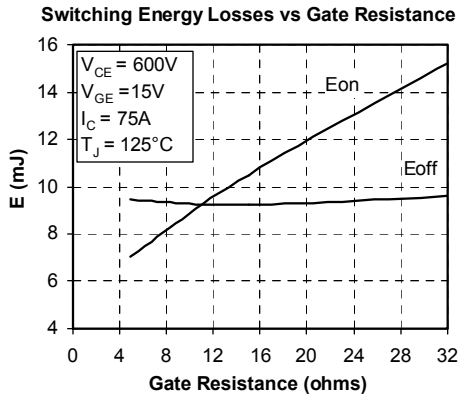
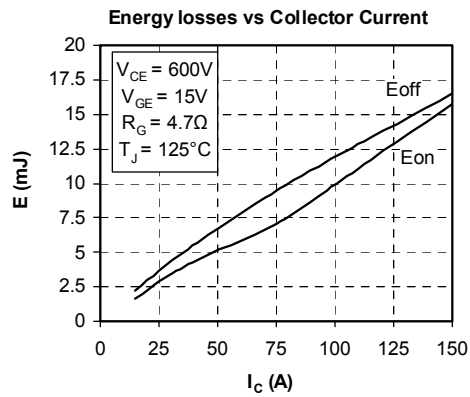
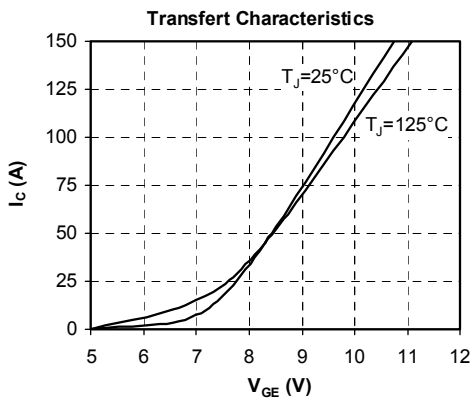
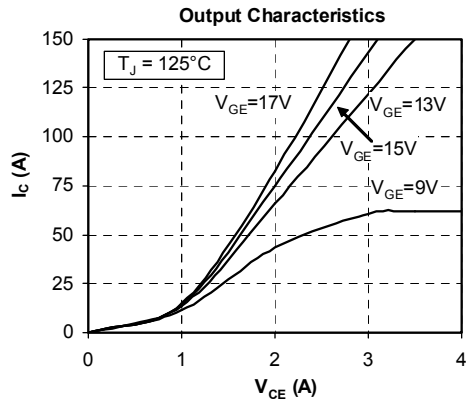
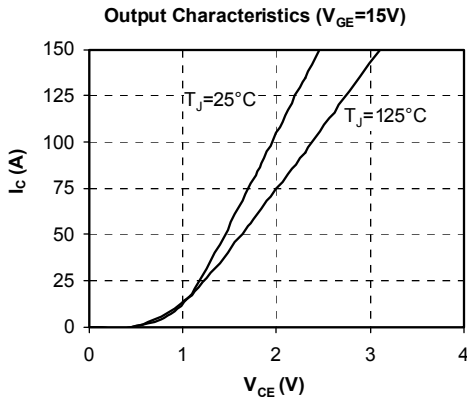

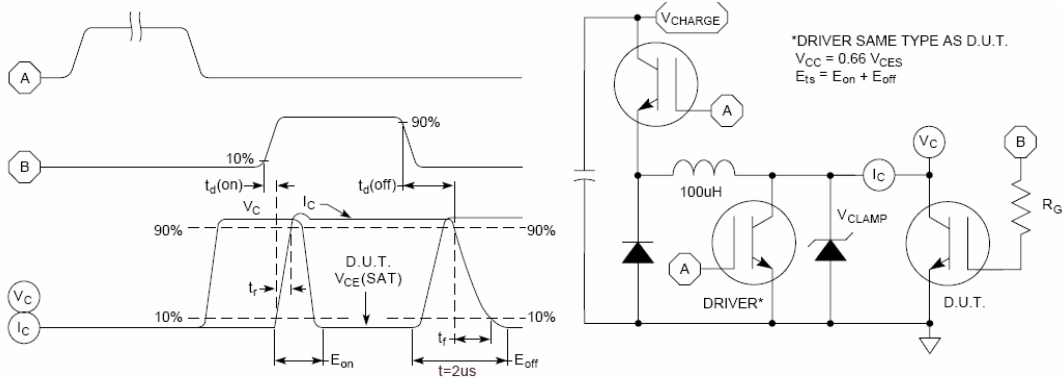

Figure 15, Switching Loss Test Circuit and Waveforms

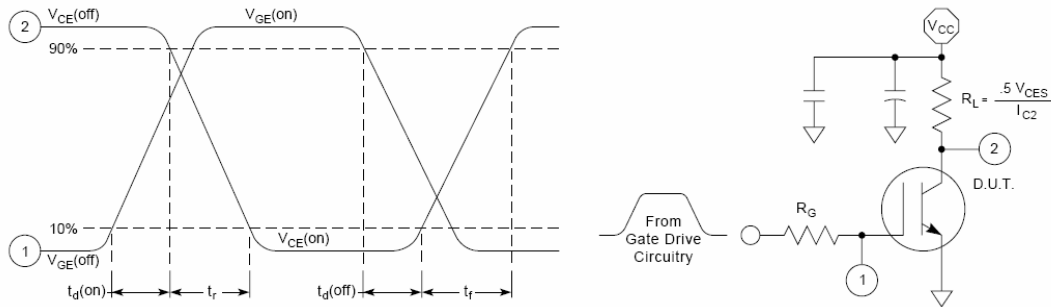

Figure 16, Resistive Switching Time Test Circuit and Waveforms

Typical Diode Performance Curve

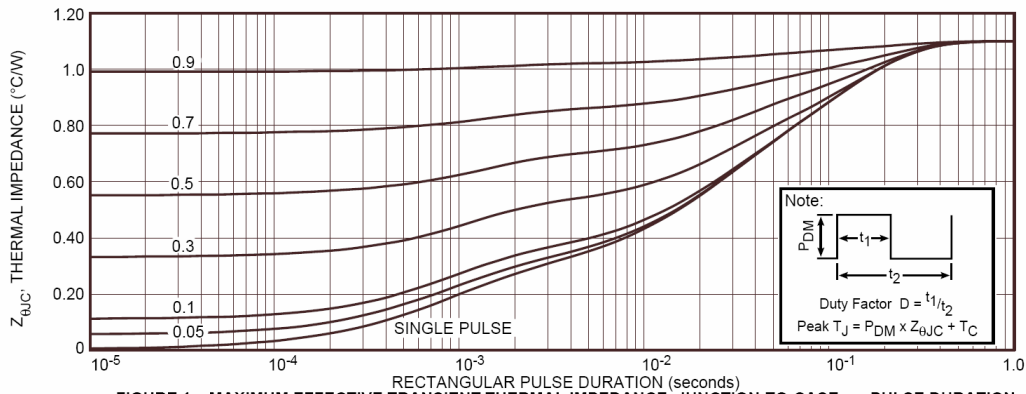

FIGURE 1a. MAXIMUM EFFECTIVE TRANSIENT THERMAL IMPEDANCE, JUNCTION-TO-CASE vs. PULSE DURATION

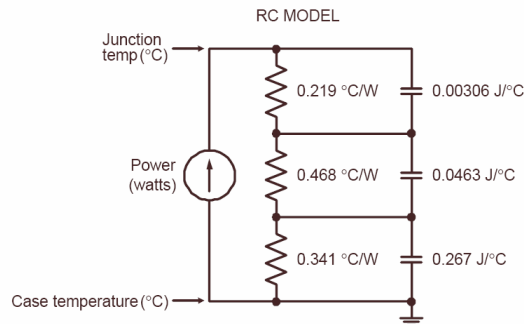

FIGURE 1b, TRANSIENT THERMAL IMPEDANCE MODEL

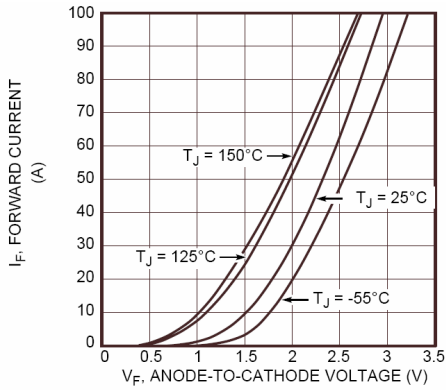

Figure 2. Forward Current vs. Forward Voltage

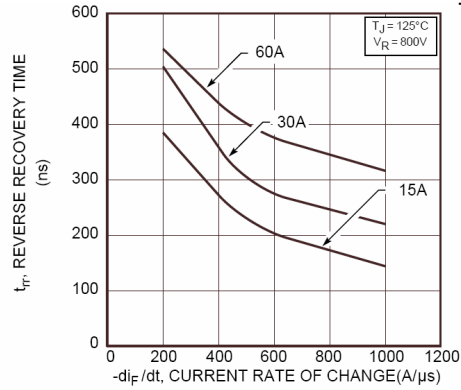

Figure 3. Reverse Recovery Time vs. Current Rate of Change

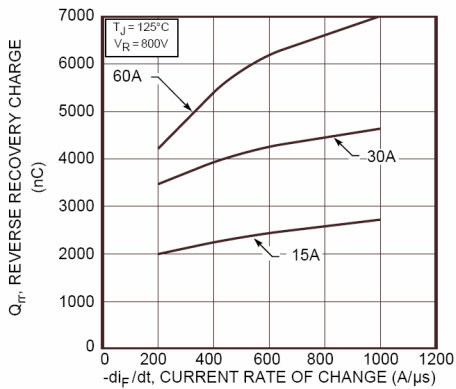

Figure 4. Reverse Recovery Charge vs. Current Rate of Change

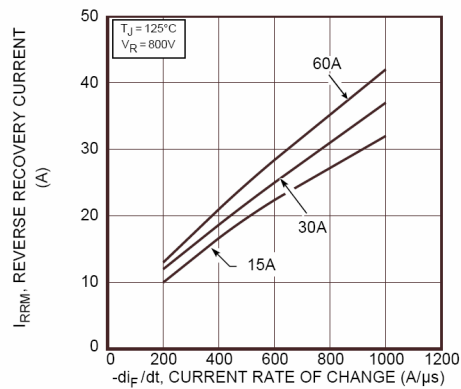

Figure 5. Reverse Recovery Current vs. Current Rate of Change

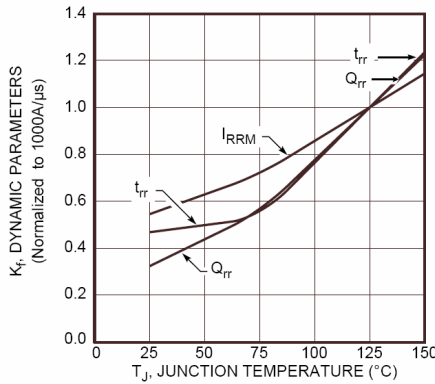

Figure 6. Dynamic Parameters vs. Junction Temperature

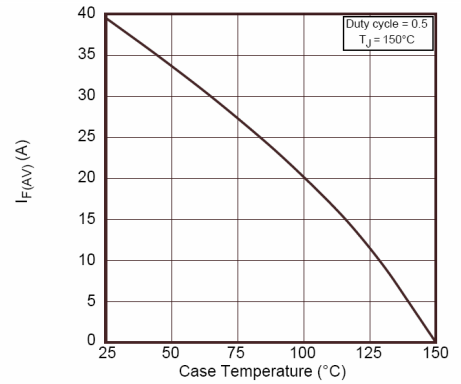

Figure 7. Maximum Average Forward Current vs. Case Temperature

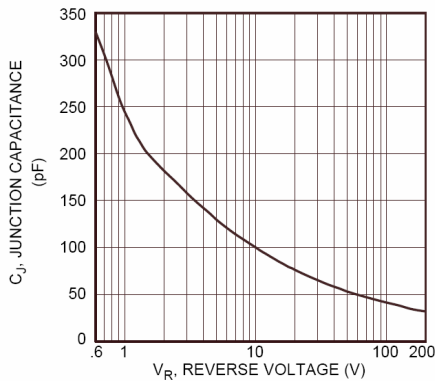

Figure 8. Junction Capacitance vs. Reverse Voltage

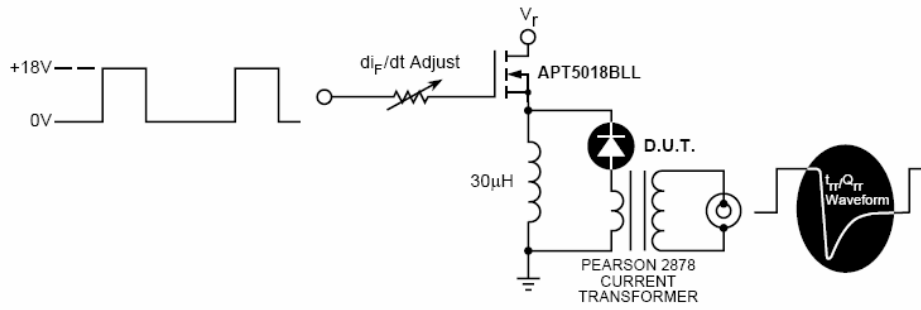

Figure 9. Diode Test Circuit

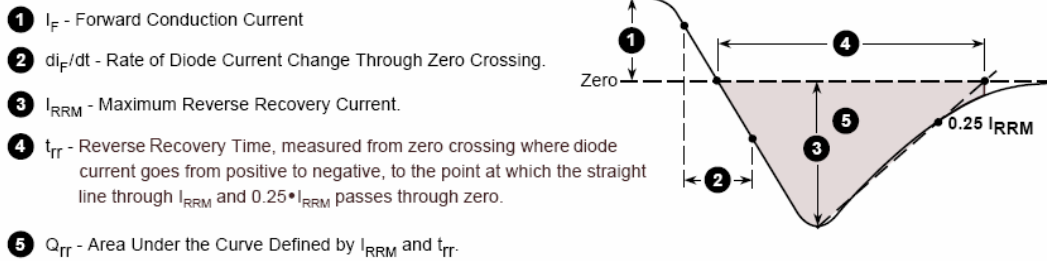
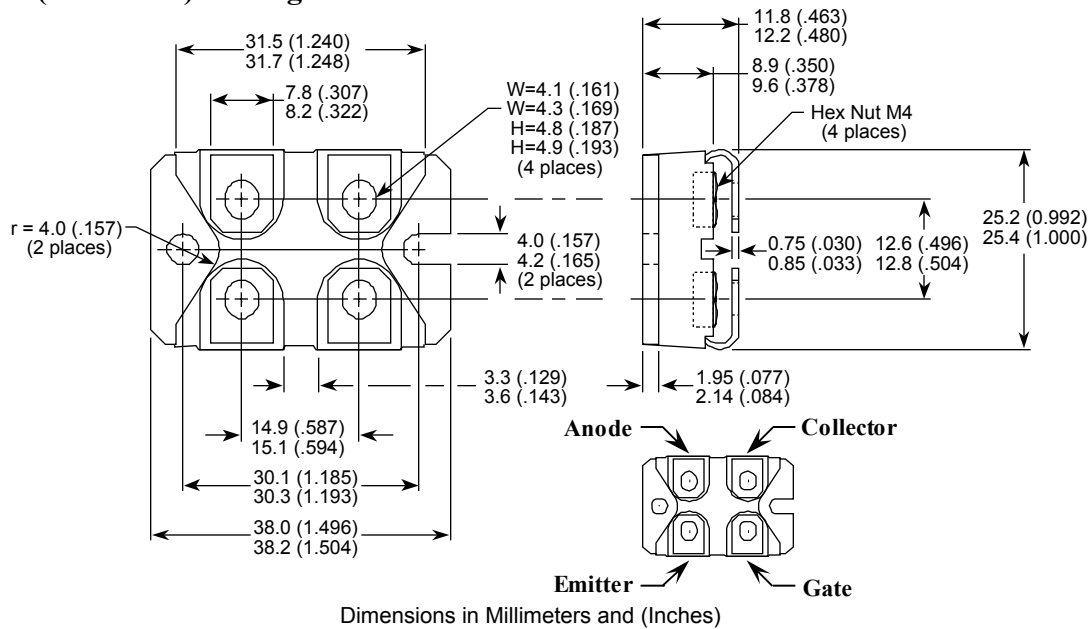

Figure 10. Diode Reverse Recovery Waveform and Definitions

SOT-227 (ISOTOP[®]) Package Outline



ISOTOP[®] is a registered trademark of ST Microelectronics NV

Microsemi reserves the right to change, without notice, the specifications and information contained herein

Microsemi's products are covered by one or more of U.S. patents 4,895,810 5,045,903 5,089,434 5,182,234 5,019,522 5,262,336 6,503,786 5,256,583 4,748,103 5,283,202 5,231,474 5,434,095 5,528,058 and foreign patents. U.S. and Foreign patents pending. All Rights Reserved.

Компания «Life Electronics» занимается поставками электронных компонентов импортного и отечественного производства от производителей и со складов крупных дистрибьюторов Европы, Америки и Азии.

С конца 2013 года компания активно расширяет линейку поставок компонентов по направлению коаксиальный кабель, кварцевые генераторы и конденсаторы (керамические, пленочные, электролитические), за счёт заключения дистрибьюторских договоров

Мы предлагаем:

- Конкурентоспособные цены и скидки постоянным клиентам.
- Специальные условия для постоянных клиентов.
- Подбор аналогов.
- Поставку компонентов в любых объемах, удовлетворяющих вашим потребностям.
- Приемлемые сроки поставки, возможна ускоренная поставка.
- Доставку товара в любую точку России и стран СНГ.
- Комплексную поставку.
- Работу по проектам и поставку образцов.
- Формирование склада под заказчика.
- Сертификаты соответствия на поставляемую продукцию (по желанию клиента).
- Тестирование поставляемой продукции.
- Поставку компонентов, требующих военную и космическую приемку.
- Входной контроль качества.
- Наличие сертификата ISO.

В составе нашей компании организован Конструкторский отдел, призванный помогать разработчикам, и инженерам.

Конструкторский отдел помогает осуществить:

- Регистрацию проекта у производителя компонентов.
- Техническую поддержку проекта.
- Защиту от снятия компонента с производства.
- Оценку стоимости проекта по компонентам.
- Изготовление тестовой платы монтаж и пусконаладочные работы.



Тел: +7 (812) 336 43 04 (многоканальный)

Email: org@lifeelectronics.ru