

General information

**IGBT Stack for typical voltages of up to 400 V_{RMS}
Rated output current 770 A_{RMS}**

- Solar power
- Motor drives
- High power converter

- 62mm power module
- Trenchstop™ IGBT4

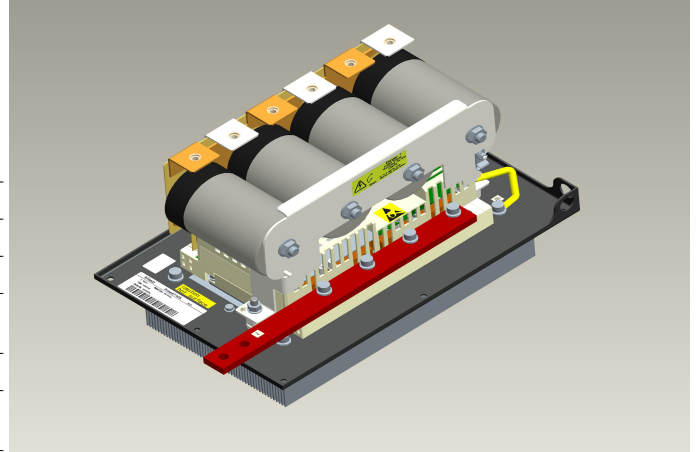

Topology	1/2 B2I
Application	Inverter
Load type	Resistive, inductive
Semiconductor (Inverter Section)	4x FF450R12KE4
DC Link	1.6 mF
Heatsink	Forced air cooled (fan not included)
Implemented sensors	Current, temperature
Driver signals IGBT	Electrical
Approvals	UL 508C
Sales - name	2PS18012E4FG38553
SP - No.	SP001062698

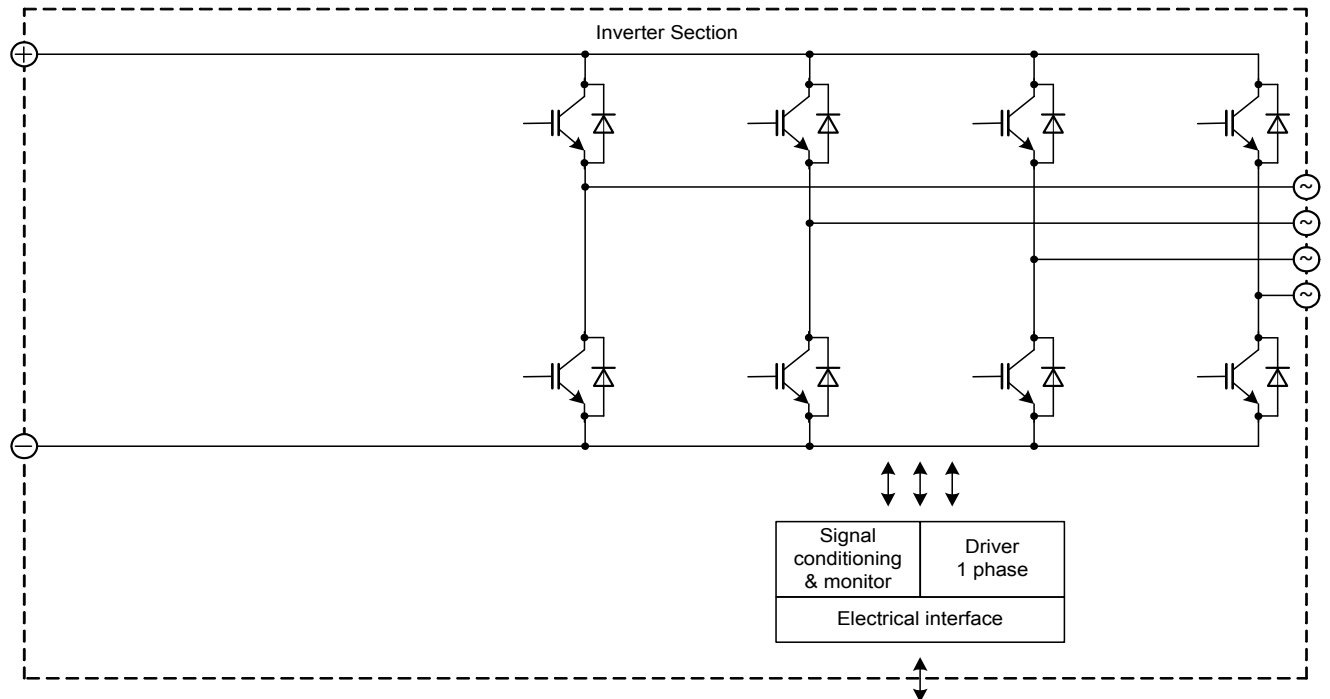

prepared by: OW	date of publication: 2014-11-18
approved by: YZ	revision: 2.0

Technical Information

PrimeSTACK™

2PS18012E44G38553



Preliminary data

Absolute maximum rated values

Collector-emitter voltage	IGBT; $T_{vj} = 25^{\circ}\text{C}$	V_{CES}	1200	V
Repetitive peak reverse voltage	Diode; $T_{vj} = 25^{\circ}\text{C}$	V_{RRM}	1200	V
DC link voltage		V_{DC}	1000	V
Insulation management	according to installation height of 2000 m	V_{line}	500	V_{RMS}
Insulation test voltage	according to EN 50178, $f = 50\text{ Hz}$, $t = 1\text{ s}$	V_{ISOL}	2.5	kV_{RMS}
Repetitive peak collector current inverter section (IGBT)	$t_p = 1\text{ ms}$	I_{CRM2}	2560	A
Repetitive peak forward current inverter section (Diode)	$t_p = 1\text{ ms}$	I_{FRM2}	2440	A
Continuous current inverter section		I_{AC2}	820	A_{RMS}
Junction temperature	under switching conditions	T_{vjop}	150	$^{\circ}\text{C}$
Switching frequency inverter section	limited due to snubber caps	f_{sw2}	3	kHz

Notes

Further maximum ratings are specified in the following dedicated sections

Characteristic values

DC Link

			min.	typ.	max.	
Rated voltage		V_{DC}		650	1000	V
Capacitor	1 s, 4 p, rated tol. 10 %	C_{DC}		1.6		mF
Maximum ripple current	per device, $T_{amb} = 55^{\circ}\text{C}$	I_{ripple}			49	A_{RMS}

Notes

Activ clamping diodes not implemented, max. DC link voltage for short circuit protection 500V
Max. DC link voltage under switching conditions 1000V up to 300A. ($T_{junction} > 25^{\circ}\text{C}$)

Inverter Section

			min.	typ.	max.	
Rated continuous current	$V_{DC} = 650\text{ V}$, $V_{AC} = 400\text{ V}_{RMS}$, $\cos(\varphi) = 0.85$, $f_{AC\ sine} = 50\text{ Hz}$, $f_{sw} = 3000\text{ Hz}$, $T_{inlet} = 50^{\circ}\text{C}$, $T_j \leq 125^{\circ}\text{C}$	I_{AC}		770		A_{RMS}
Rated continuous current for 150% overload capability	$I_{AC\ 150\%} = 820\text{ A}_{RMS}$, $t_{on\ over} = 60\text{ s}$, $T_j \leq 125^{\circ}\text{C}$	$I_{AC\ over1}$			550	A_{RMS}
Rated continuous current for 150% overload capability	$I_{AC\ 150\%} = 820\text{ A}_{RMS}$, $t_{on\ over} = 3\text{ s}$, $T_j \leq 125^{\circ}\text{C}$	$I_{AC\ over2}$			630	A_{RMS}
Over current shutdown	within 15 μs	$I_{AC\ OC}$		1280		A_{peak}
Power losses	$I_{AC} = 400\text{ A}$, $V_{DC} = 650\text{ V}$, $\cos(\varphi) = 0.85$, $f_{AC\ sine} = 50\text{ Hz}$, $f_{sw} = 3000\text{ Hz}$, $T_{inlet} = 50^{\circ}\text{C}$, $T_j \leq 125^{\circ}\text{C}$	P_{loss}		5600		W

Notes

Maximum junction temperature limited to 125°C under all operating conditions

prepared by: OW	date of publication: 2014-11-18
approved by: YZ	revision: 2.0

Technical Information

PrimeSTACK™

2PS18012E44G38553



Preliminary data

Controller interface

Driver and interface board	ref. to separate Application Note		DR240			
			min.	typ.	max.	
Auxiliary voltage		V_{aux}	18	24	30	V
Auxiliary power requirement	$V_{aux} = 24\text{ V}$	P_{aux}			40	W
Digital input level	resistor to GND 10 k Ω , capacitor to GND 1 nF	$V_{in\ low}$	0		4	V
		$V_{in\ high}$	11		15	V
Digital output level	open collector, logic low = no fault, max. 15 mA	$V_{out\ low}$	0		1.5	V
		$V_{out\ high}$		15		V
Analog current sensor output inverter section	load max 5 mA, @ 770 A _{RMS}	$V_{IU\ ana2}$ $V_{IV\ ana2}$ $V_{IW\ ana2}$	6	6.1	6.2	V
Over temperature shutdown inverter section	load max 5 mA, @ T _{NTC} = 86 °C	$V_{Error\ OT2}$	10.8	11	11.2	V

System data

			min.	typ.	max.	
EMC robustness	according to IEC 61800-3 at named interfaces	power	V_{Burst}	2		kV
		control	V_{Burst}	1		kV
		aux (24V)	V_{surge}	1		kV
Storage temperature		T_{stor}	-40		80	°C
Operational ambient temperature	PCB, DC link capacitor, bus bar, excluding cooling medium	$T_{op\ amb}$	-25		60	°C
Cooling air velocity	PCB, DC link capacitor, bus bar, standard atmosphere	V_{air}	2			m/s
Humidity	no condensation	Rel. F	0		85	%
Vibration	according to IEC 60721				5	m/s ²
Shock	according to IEC 60721				50	m/s ²
Protection degree			IP00			
Pollution degree			2			
Dimensions	width x depth x height		284	472	287	mm
Weight				19		kg

Notes

System data valid for continuous operation

Heatsink air cooled

			min.	typ.	max.	
Air flow	$T_{air} = 20\text{ °C}$, $P_{air} = 1013\text{ hPa}$, dry and dust free, measured at the side of the heat sink according to DIN 41882	$\Delta V/\Delta t$	500			m ³ /h
Air pressure drop	at min. air flow	Δp		200		Pa
Air inlet temperature		T_{inlet}	-30		55	°C

Notes

Conditions are standard Infineon characterization for heatsinks.

prepared by: OW	date of publication: 2014-11-18
approved by: YZ	revision: 2.0

Technical Information

PrimeSTACK™

2PS18012E44G38553



Preliminary data

Overview of optional components

	Unit 1	Inverter Section	Unit 3
Parallel interface board			
Optical interface board			
Voltage sensor			
Current sensor		x	
Temperature sensor		x	
Temperature simulation			
DC link capacitors		x	
Data cable for control signals			
Fan			
Collector-emitter Active Clamping			
Snubber capacitors		x	

prepared by: OW	date of publication: 2014-11-18
approved by: YZ	revision: 2.0



Preliminary data

$f_{AC\ sine}$ - derating curve IGBT (motor), Diode (generator)
 $V_{DC} = 650\ V$, $V_{AC} = 400\ V_{RMS}$, $f_{sw} = 3\ kHz$, $\cos\phi = \pm 0.85$,
 $T_{inlet} = 50\ ^\circ C$ and nom. cooling conditions

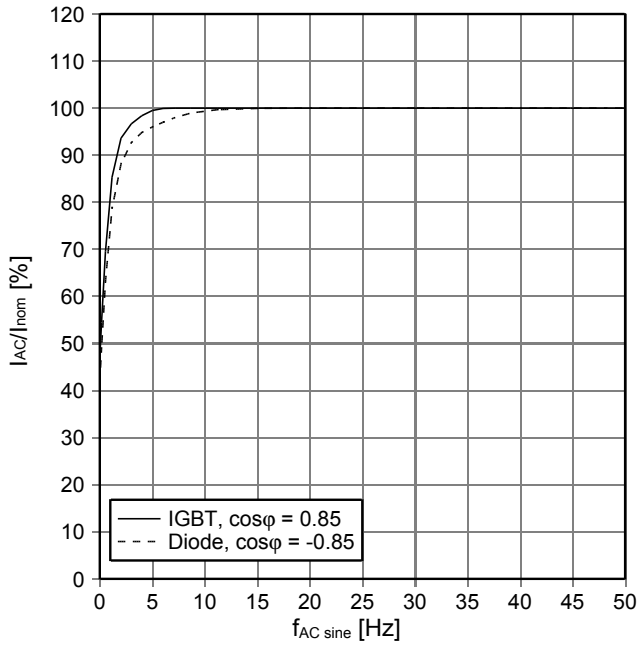

T_{inlet} - derating curve IGBT (motor), Diode (generator)
 $V_{DC} = 650\ V$, $V_{AC} = 400\ V_{RMS}$, $f_{AC\ sine} = 50\ Hz$, $\cos\phi = \pm 0.85$,
 $T_{inlet} = 50\ ^\circ C$ and nom. cooling conditions

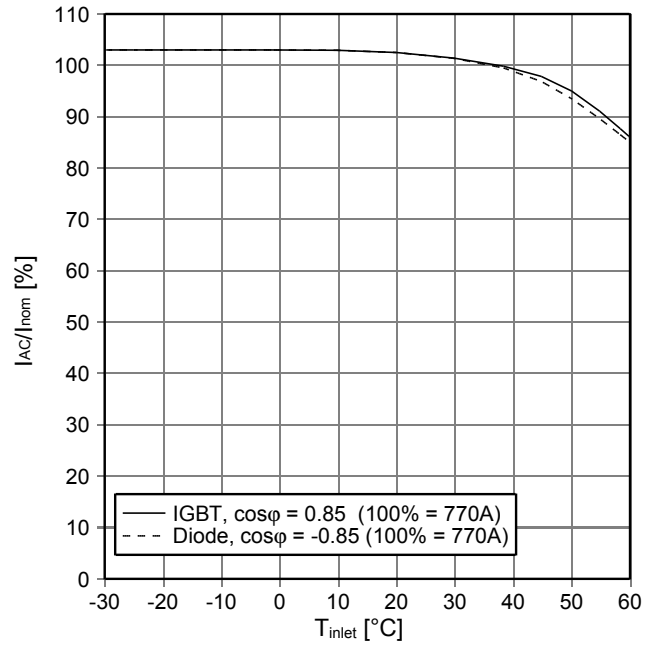

Analog temperature sensor output $V_{Theta\ NTC}$
 Sensing NTC of heatsink

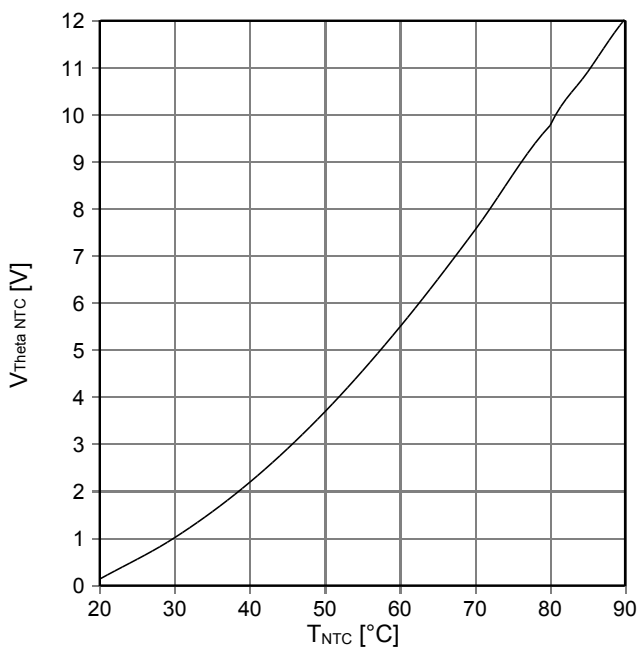

$Z_{th,ha}$ - thermal impedance heatsink to ambient per switch
 nom. cooling conditions

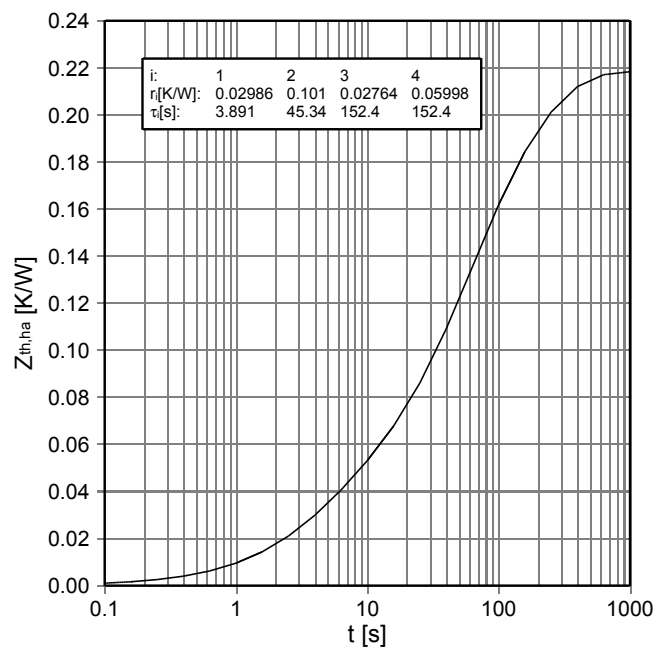

prepared by: OW	date of publication: 2014-11-18
approved by: YZ	revision: 2.0

Mechanical drawing

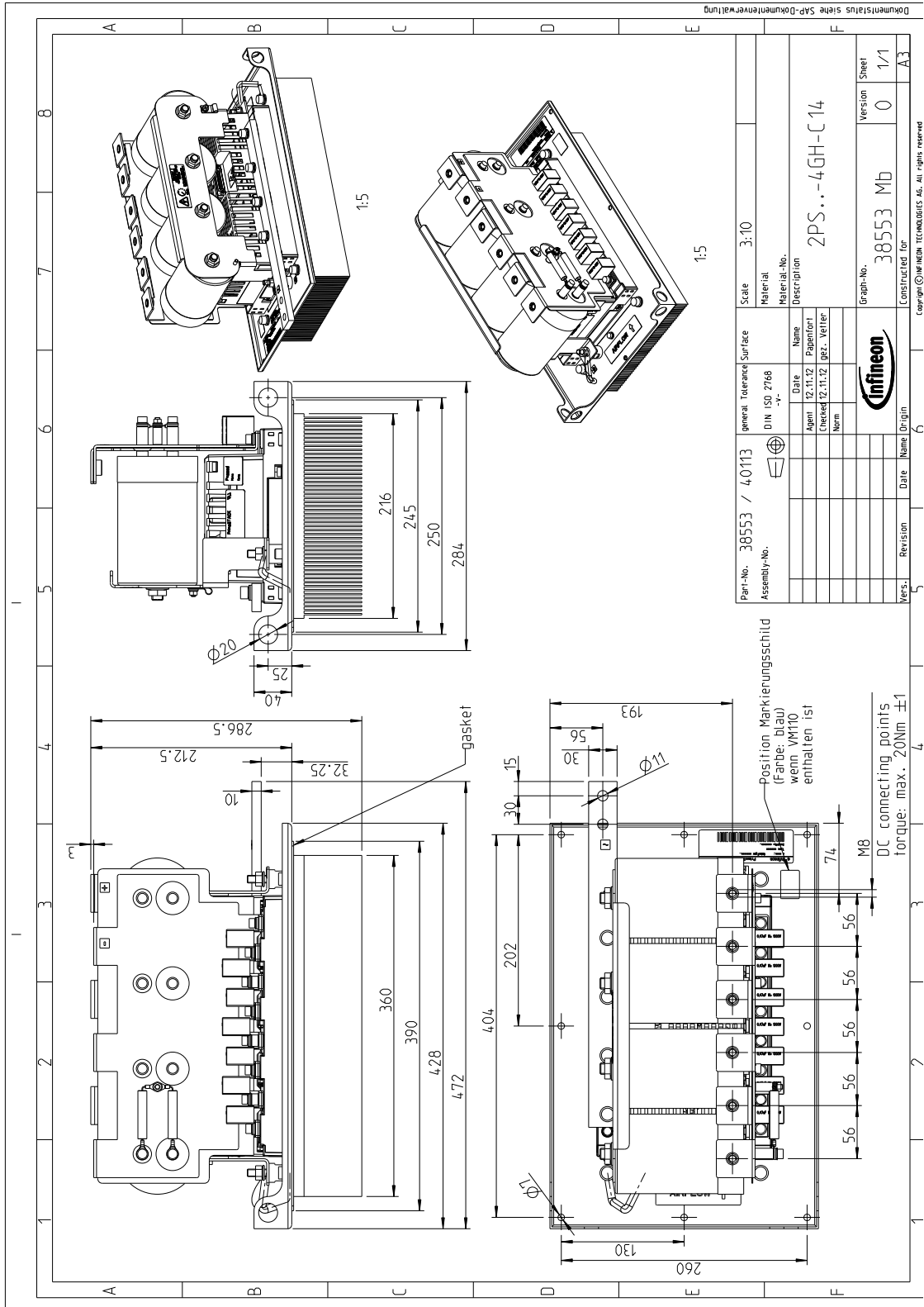

prepared by: OW	date of publication: 2014-11-18
approved by: YZ	revision: 2.0

Circuit diagram

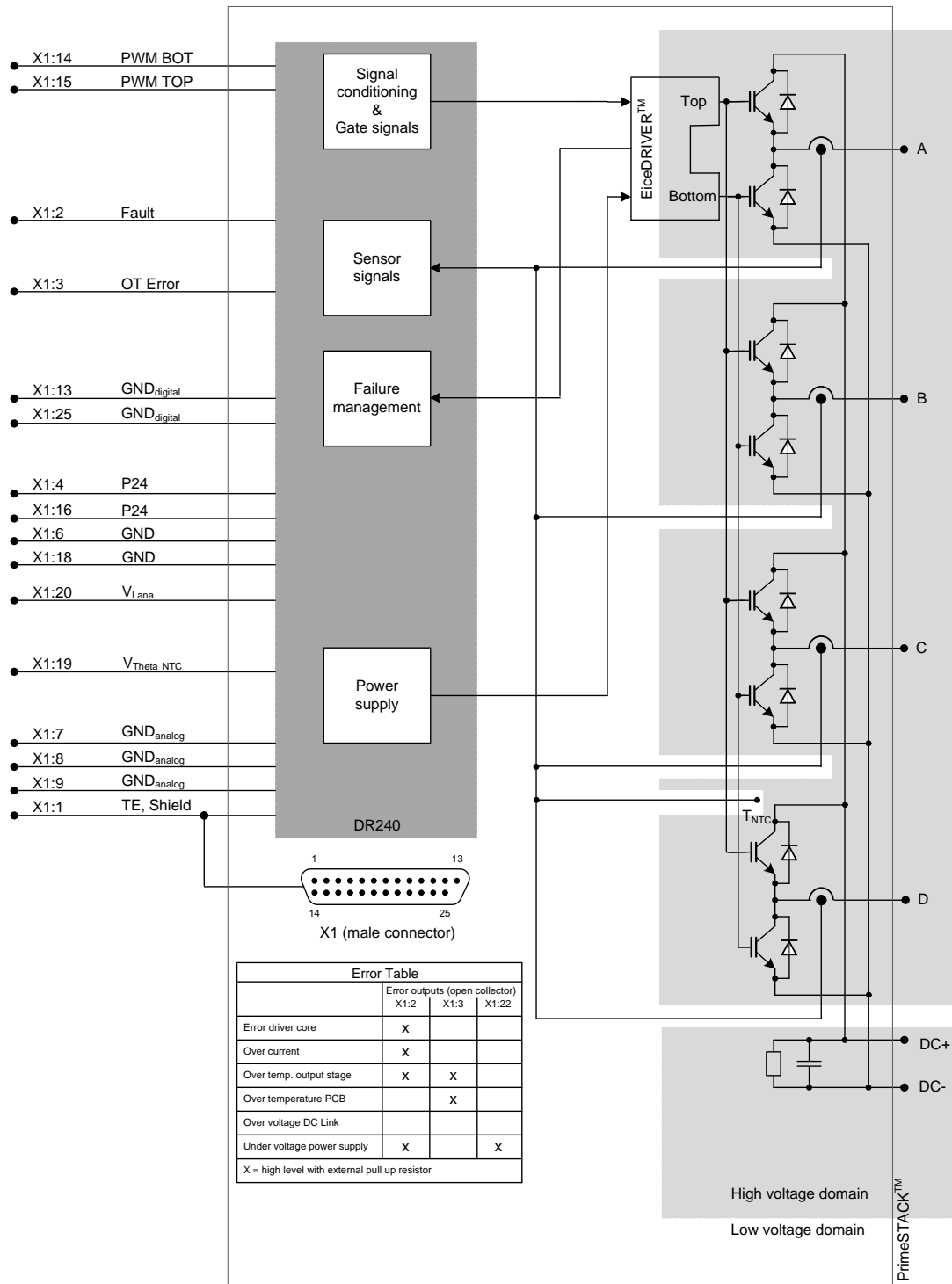

Technical Information

PrimeSTACK™

2PS18012E44G38553



Preliminary data

Terms & Conditions of usage

The data contained in this product data sheet is exclusively intended for technically trained staff. You and your technical departments will have to evaluate the suitability of the product for the intended application and the completeness of the product data with respect to such application.

This product data sheet is describing the characteristics of this product for which a warranty is granted. Any such warranty is granted exclusively pursuant the terms and conditions of the supply agreement. There will be no guarantee of any kind for the product and its characteristics.

Should you require product information in excess of the data given in this product data sheet or which concerns the specific application of our product, please contact the sales office, which is responsible for you (see www.infineon.com, sales&contact). For those that are specifically interested we may provide application notes.

Due to technical requirements our product may contain dangerous substances. For information on the types in question please contact the sales office, which is responsible for you.

Should you intend to use the Product in aviation applications, in health or live endangering or life support applications, please notify.

Please note, that for any such applications we urgently recommend

- to perform joint Risk and Quality Assessments;
- the conclusion of Quality Agreements;
- to establish joint measures of an ongoing product survey,
and that we may make delivery depended on the realization
of any such measures.

If and to the extent necessary, please forward equivalent notices to your customers.

Changes of this product data sheet are reserved.

Safety Instructions

Prior to installation and operation, all safety notices and warnings and all warning signs attached to the equipment have to be carefully read. Make sure that all warning signs remain in a legible condition and that missing or damaged signs are replaced. To installation and operation, all safety notices and warnings and all warning signs attached to the equipment have to be carefully read. Make sure that all warning signs remain in a legible condition and that missing or damaged signs are replaced.

prepared by: OW	date of publication: 2014-11-18
approved by: YZ	revision: 2.0

Компания «Life Electronics» занимается поставками электронных компонентов импортного и отечественного производства от производителей и со складов крупных дистрибьюторов Европы, Америки и Азии.

С конца 2013 года компания активно расширяет линейку поставок компонентов по направлению коаксиальный кабель, кварцевые генераторы и конденсаторы (керамические, пленочные, электролитические), за счёт заключения дистрибьюторских договоров

Мы предлагаем:

- Конкурентоспособные цены и скидки постоянным клиентам.
- Специальные условия для постоянных клиентов.
- Подбор аналогов.
- Поставку компонентов в любых объемах, удовлетворяющих вашим потребностям.
- Приемлемые сроки поставки, возможна ускоренная поставка.
- Доставку товара в любую точку России и стран СНГ.
- Комплексную поставку.
- Работу по проектам и поставку образцов.
- Формирование склада под заказчика.
- Сертификаты соответствия на поставляемую продукцию (по желанию клиента).
- Тестирование поставляемой продукции.
- Поставку компонентов, требующих военную и космическую приемку.
- Входной контроль качества.
- Наличие сертификата ISO.

В составе нашей компании организован Конструкторский отдел, призванный помогать разработчикам, и инженерам.

Конструкторский отдел помогает осуществить:

- Регистрацию проекта у производителя компонентов.
- Техническую поддержку проекта.
- Защиту от снятия компонента с производства.
- Оценку стоимости проекта по компонентам.
- Изготовление тестовой платы монтаж и пусконаладочные работы.



Тел: +7 (812) 336 43 04 (многоканальный)

Email: org@lifeelectronics.ru