



**SERIES:** VLD25-DIP | **DESCRIPTION:** LED DRIVER

**FEATURES**

- power LED driver
- wide input and output voltage range
- DIP package
- constant current output
- PWM dimming and analog dimming
- short circuit protection
- high efficiency up to 95%

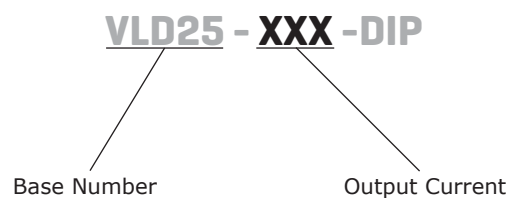

MODEL	input voltage range (Vdc)	output voltage range (Vdc)	output current range (mA)	ripple and noise max (mVp-p)	dimming control	efficiency typ (%)
	VLD25-300-DIP	5.5 ~ 46	3.3 ~ 36	0 ~ 300	120	PWM+analog
VLD25-350-DIP	5.5 ~ 46	3.3 ~ 36	0 ~ 350	120	PWM+analog	95
VLD25-500-DIP	5.5 ~ 46	3.3 ~ 36	0 ~ 500	120	PWM+analog	95
VLD25-600-DIP	5.5 ~ 46	3.3 ~ 36	0 ~ 600	120	PWM+analog	95
VLD25-700-DIP	5.5 ~ 46	3.3 ~ 36	0 ~ 700	120	PWM+analog	95

**PART NUMBER KEY**

## INPUT

parameter	conditions/description	min	typ	max	units
operating input voltage	absolute max before device failure	5		55	Vdc
	operating input range	5.5	24	46	Vdc
quiescent input current in off mode	Vin = 24 V, Vc < 0.6 V		400		µA
filter	capacitor		1		µF
remote on/off	dc-dc ON dc-dc OFF		open or 2.8 V < Vc < 6V Vc < 0.6 V		
remote pin current	Vc = 5V			1	mA
PWM frequency				0.2	kHz
input voltage - analog dimming	Vin = 5.5 ~ 4.6 V	0		15	V
control voltage - analog dimming	full on	0.15	0.20	0.25	V
	full off	4.3	4.5	4.7	V
driving current - analog dimming	Vc = 5 V			0.2	A

## OUTPUT

parameter	conditions/description	min	typ	max	units
voltage range	Vin = 46 V, Vo = 3.3 V ~ 36 V	3.3		36	Vdc
voltage drop	Vin = 5.5 ~ 46 V, 1 ~ 10 LED	2	3	4	Vdc
current accuracy	300~600 mA		±3	±5	%
	700 mA		±5	±7	%
output current range - analog dimming	Vin = 5.5 ~ 46 V, 1 ~ 10 LED	0		100	%
current stability	Vin = 46 V, Vo = 3.3 V ~ 36 V			±1	%
temperature coefficient	-40 ~ 71°C ambient			±0.015	%/°C
capacitive load				1,000	µF

## PROTECTIONS

parameter	conditions/description	min	typ	max	units
short circuit protection	continuous automatic recovery				

## SAFETY AND COMPLIANCE

parameter	conditions/description	min	typ	max	units
EMI/EMC	EN 55015 power port, CISPR22 Class B, IEC/EN 61000-4-(2, 3, 4, 5, 6)				
RoHS compliant	yes				

## ENVIRONMENTAL

parameter	conditions/description	min	typ	max	units
operating temperature	300/350 mA	-40		85	°C
	500/600/700 mA	-40		71	°C
storage temperature		-55		125	°C
maximum case temperature				100	°C

## DERATING CURVE

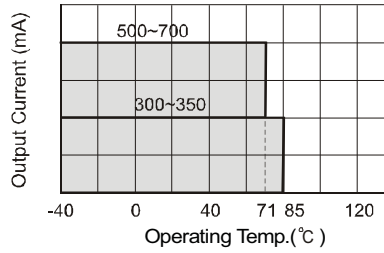

## MECHANICAL

parameter	conditions/description	min	typ	max	units
dimensions	0.898 x 0.402 x 0.535 inch (22.80 x 10.20 x 13.60 mm)				
case material	epoxy resin (UL94-V0)				
weight			4.3		g

## MECHANICAL DRAWING

unit: mm(inch)

Pin tolerances:  $\pm 0.10\text{mm}(\pm 0.039\text{inch})$

General tolerances:  $\pm 0.25\text{mm}(\pm 0.010\text{inch})$

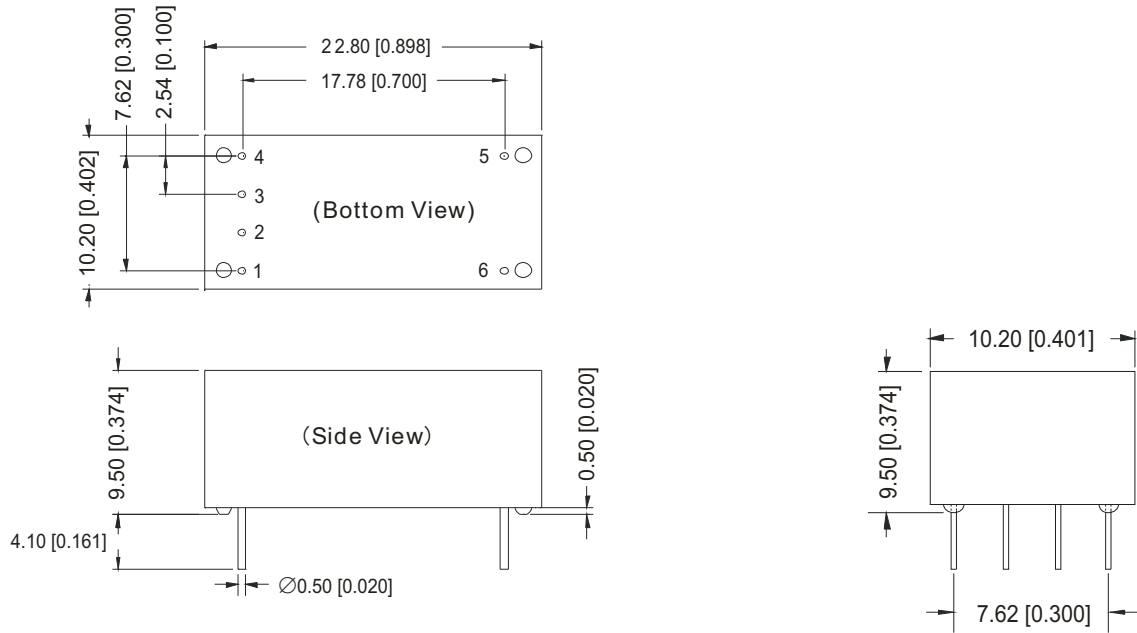

PIN CONNECTIONS	
Pin	Function
1	Vin
2	analog dimming
3	ON/OFF/PWM
4	GND
5	-Vout
6	+Vout

## RECOMMENDED FOOTPRINT (TOP VIEW)

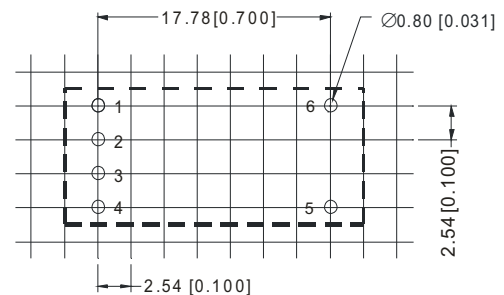

## APPLICATION NOTES

### 1. Typical Application Circuits

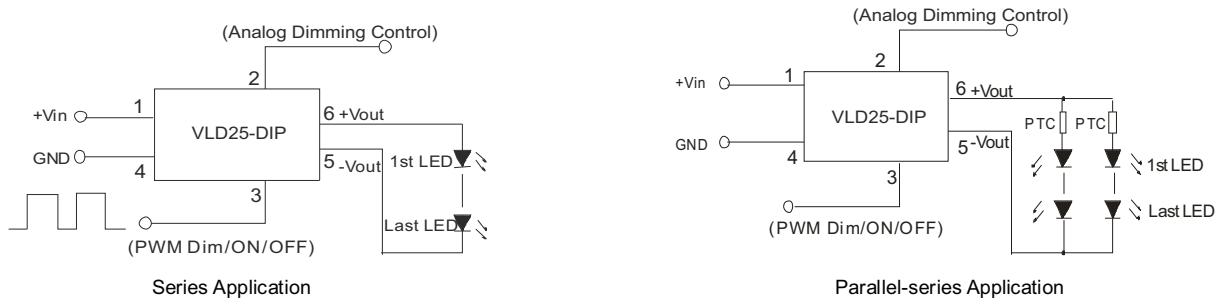

To protect the LED(s), you could connect a PTC to input of all channels as shown in application circuit.  
 Note: Negative output terminal should not connected to GND. Module may be damaged.

### 2. Digital Dimming Control

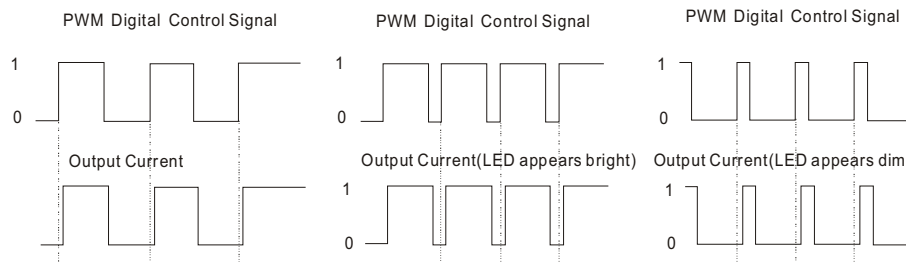

Formula for output current:

$$I_{o,set} = \frac{(DT-0.8)}{T} I_{o,norm}$$

$I_{o,set}$  refers to the expected output current value.  
 $I_{o,norm}$  refers to the rated output current  
 D refers to the pulse width of the PWM signal  
 T refers to the cycle of the PWM signal

Note: This formula is only supplied as a reference and the output current may be deviated from for different load conditions. The Ton(min) of PWM signal must be greater than 0.8ms, otherwise the driver cannot be operated normally. It is natural for the driver to generate audible noise during dimming process because the frequency of the control circuit is within human audible range (20Hz~20kHz). In order to make the LED flashes not visible to human eye, the PWM dimming frequency is recommended to be set above 100Hz. PWM curve (Vin=24 V, 5 LEDs)

### 3. Analog Dimming Control and Application Example

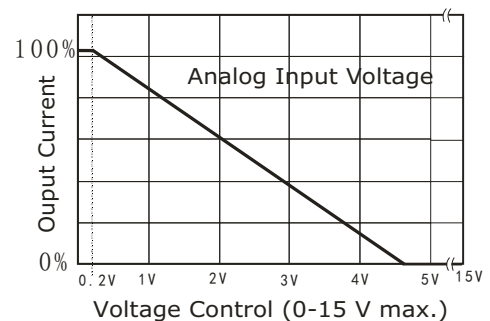
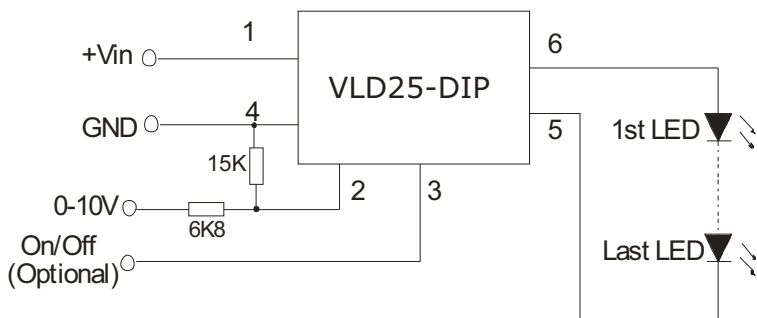

**4. EMC Recommended Circuit**

EMI/EMC recommended circuit

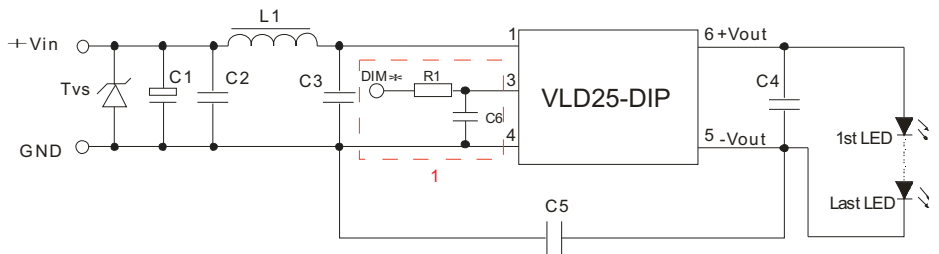

RECOMMENDED PARAMETERS	
COMPONENTS	SPECIFICATIONS
Tvs	SMC51A, 1500 W (ON)
L1	CD53-82μH (CEAIYA)
C1	470μF/100V (NCC)
C2	225K/50V 1210 X7R (TORCH)
C3	104K/50V 0805 X7R (TORCH)
C4	105K/50V 0805 X7R (TORCH)
C5	102K/2000V 1210 (TDK)
C6	470pF/100V 0805 (TORCH)
R1	680Ω 0805 (can be replaced by inductance or magnetic bead)

## REVISION HISTORY

---

rev.	description	date
1.0	initial release	10/15/2012
1.01	misc. updates	11/02/2012
1.02	added product photo	11/28/2012

The revision history provided is for informational purposes only and is believed to be accurate.

**CUI INC<sup>®</sup>**

**Headquarters**  
20050 SW 112th Ave.  
Tualatin, OR 97062  
**800.275.4899**

Fax 503.612.2383  
**cui.com**  
techsupport@cui.com

CUI offers a two (2) year limited warranty. Complete warranty information is listed on our website.

CUI reserves the right to make changes to the product at any time without notice. Information provided by CUI is believed to be accurate and reliable. However, no responsibility is assumed by CUI for its use, nor for any infringements of patents or other rights of third parties which may result from its use.

CUI products are not authorized or warranted for use as critical components in equipment that requires an extremely high level of reliability. A critical component is any component of a life support device or system whose failure to perform can be reasonably expected to cause the failure of the life support device or system, or to affect its safety or effectiveness.

Компания «Life Electronics» занимается поставками электронных компонентов импортного и отечественного производства от производителей и со складов крупных дистрибьюторов Европы, Америки и Азии.

С конца 2013 года компания активно расширяет линейку поставок компонентов по направлению коаксиальный кабель, кварцевые генераторы и конденсаторы (керамические, пленочные, электролитические), за счёт заключения дистрибьюторских договоров

Мы предлагаем:

- Конкурентоспособные цены и скидки постоянным клиентам.
- Специальные условия для постоянных клиентов.
- Подбор аналогов.
- Поставку компонентов в любых объемах, удовлетворяющих вашим потребностям.
- Приемлемые сроки поставки, возможна ускоренная поставка.
- Доставку товара в любую точку России и стран СНГ.
- Комплексную поставку.
- Работу по проектам и поставку образцов.
- Формирование склада под заказчика.
- Сертификаты соответствия на поставляемую продукцию (по желанию клиента).
- Тестирование поставляемой продукции.
- Поставку компонентов, требующих военную и космическую приемку.
- Входной контроль качества.
- Наличие сертификата ISO.

В составе нашей компании организован Конструкторский отдел, призванный помогать разработчикам, и инженерам.

Конструкторский отдел помогает осуществить:

- Регистрацию проекта у производителя компонентов.
- Техническую поддержку проекта.
- Защиту от снятия компонента с производства.
- Оценку стоимости проекта по компонентам.
- Изготовление тестовой платы монтаж и пусконаладочные работы.



Тел: +7 (812) 336 43 04 (многоканальный)  
Email: [org@lifeelectronics.ru](mailto:org@lifeelectronics.ru)