

Low-Power Single/Dual-Supply Quad Comparator with Reference

FEATURES

- Single or Dual Power Supplies:
Single: +2.5V to +11V
Dual: $\pm 1.25V$ to $\pm 5.5V$
- Internal $1.182V \pm 0.75\%$ Reference
- Fully Assembled and Tested
- Push-pull TTL/CMOS-Compatible Outputs
- 2in x 3in 2-layer circuit board

DESIGNATION	QTY	DESCRIPTION
C2	1	0.1 μ F $\pm 10\%$ capacitors (0805)
R1, R4	1	40.2k $\Omega \pm 1\%$ resistor (0805)
R2, R3	1	26.1k $\Omega \pm 1\%$ resistor (0805)
R5, R6	1	2M $\Omega \pm 1\%$ resistor (0805)
U1	1	TS9004 Comparator
INA-, INB+, OUTA, OUTB, VDD, REF, GND (6)	12	Test points

Table 1. Component List

DESCRIPTION

The demo board for the TS9004 is a completely assembled and tested circuit board that can be used for evaluating the TS9004. The TS9004 joins Touchstone's TS9002 and TS9001-1/2 analog comparators in the "NanoWatt Analog™" high performance analog integrated circuits portfolio. The TS9004 can operate from single +2.5V to +11V supplies or from $\pm 1.25V$ to $\pm 5.5V$ dual supplies.

The TS9004 is fully specified over the $-40^{\circ}C$ to $+85^{\circ}C$ temperature range and is available in a 16-pin narrow SOIC package.

Product data sheets and additional documentation can be found on factory web site at www.touchstonesemi.com.

ORDERING INFORMATION

Order Number	Description
TS9004DB	Demo Board

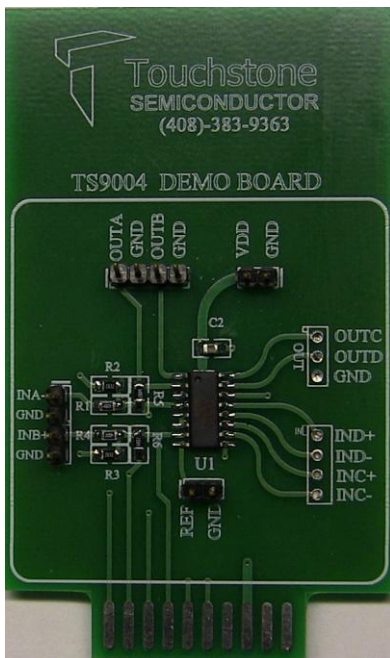

Figure 1. TS9004 Evaluation Board (Top View)

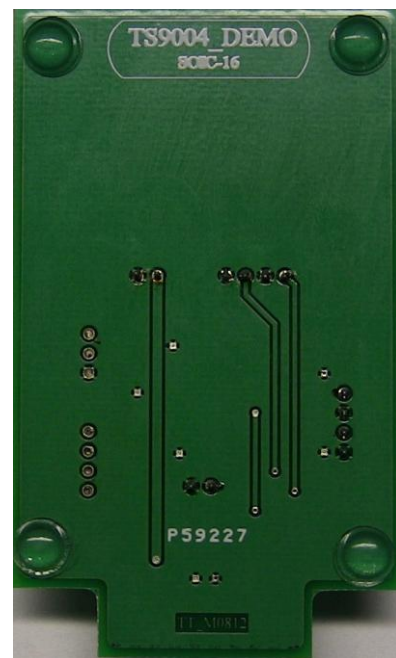

Figure 2. TS9004 Evaluation Board (Bottom View)

DESCRIPTION

The demo board provides a configuration where only three resistors are required to set the hysteresis band, V_{HB} , as shown in Figure 3. Adding comparator hysteresis creates two trip points: V_{THR} (for the rising input voltage) and V_{THF} (for the falling input voltage). The hysteresis band (V_{HB}) is defined as the voltage difference between the two trip points.

To design the circuit for a desired hysteresis band, refer to page 10 of the TS9004 product datasheet. To verify the trip voltages and hysteresis band using the standard resistance values, use the following equations:

$$V_{THR} = V_{REF} \times R1 \times \left(\frac{1}{R4} + \frac{1}{R3} + \frac{1}{R6} \right)$$

$$V_{THF} = V_{THR} - \frac{(R4 \times VDD)}{R6}$$

$$V_{HB} = V_{THR} - V_{THF}$$

The TS9004 demo board provides $R1 = R4 = 40.2k\Omega$, $R2 = R3 = 26.1k\Omega$, and $R5 = R6 = 2M\Omega$. This sets the hysteresis band to approximately $V_{HB} = 100mV$ with V_{THR} and V_{THF} set to approximately 3.026V and 2.903V, respectively.

QUICK START PROCEDURES

Required Equipment

- TS9004DB demo board
- A DC Power Supply, an HP Model HP6624A or equivalent
- A Precision DC Source/Calibrator, a Krohn-Hite Model 526 or equivalent
- A Digital Voltmeter
- A Digital Ammeter
- Oscilloscope Model Agilent DSO1014A or equivalent (AC input only)
- 1M Ω oscilloscope probe (AC input only)
- Function Generator (AC input only)

To evaluate the TS9004 comparators, the following steps are to be performed:

- 1) Before connecting the DC power supply to the demo board power test points, turn on the power supply and set the DC voltage to 5V and then turn it off.
- 2) Set the DC source/calibrator voltage to 2.8V and turn it off.
- 3) Connect the positive terminal of the DC power supply to the V_{DD} jumper on the demo board and the negative terminal to the positive terminal of the ammeter. Then, connect the negative terminal of the ammeter to a GND jumper on the demo board.
- 4) Connect the positive terminal of the DC source/calibrator to the INB+ jumper on the demo board and the negative terminal to a GND jumper on the demo board.
- 5) Connect the positive terminal of the DC voltmeter to the OUTB jumper on the demo board and the negative terminal to a GND jumper on the demo board.
- 6) Turn on the power supply and the DC source/calibrator and check that the power supply current is approximately 6 μ A, including any currents through external resistors.
- 7) Slowly increase the DC source/calibrator voltage until the output of the comparator switches to approximately 5V. Refer to the voltmeter. The output should switch from a low state to a high state at approximately 3.026V. The power supply current is now approximately 8 μ A.
- 8) Now, slowly decrease the DC source/calibrator voltage until the output of the comparator drops to approximately 0V. Refer to the voltmeter. The output should switch from a high state to a low state at approximately 2.903V. The power supply current is approximately 6 μ A.
- 9) To measure the reference voltage, connect the positive terminal of a voltmeter to the REF jumper on the demo board and the negative terminal to a GND jumper on the demo board.

- 10) If testing with an AC input signal is desired, use a function generator and set the offset voltage, amplitude, and frequency to 3V, 400mV, and 1kHz, respectively. Connect the positive terminal of the function generator to the INB+ jumper and the negative terminal to the GND jumper on the board. Then, use the oscilloscope and the oscilloscope probe to monitor the output OUTB.
- 11) If the evaluation of comparator A is desired,

follow the previous steps. However, note that the output signal OUTA is configured to be the inverted version of comparator B's output OUTB.

- 12) Evaluation of comparator C and D can be performed on the TS9004 demo board. Access to the input and output of comparator C and D is available as shown in Figure 3.

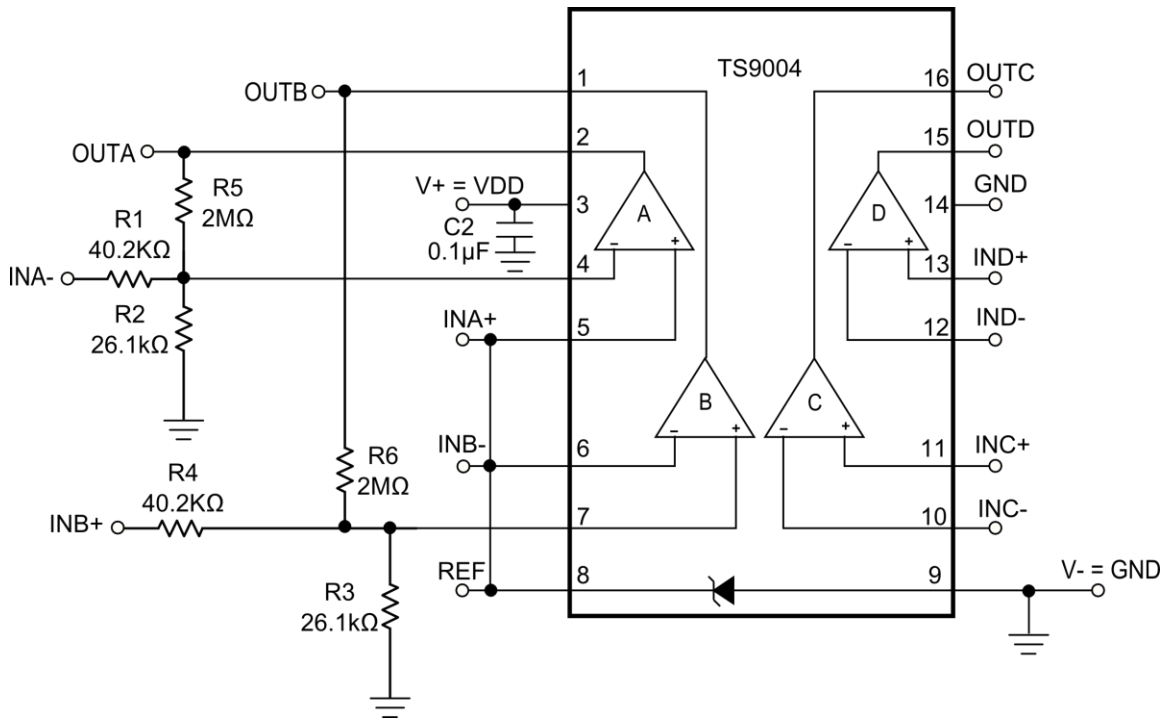

Figure 3. TS9004 Demo Board Circuit

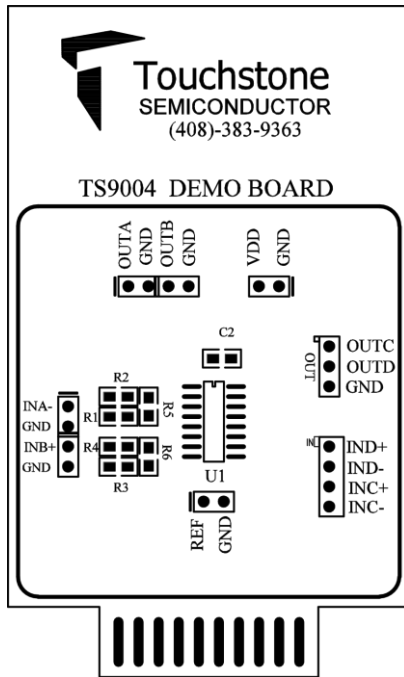

Figure 4. Top Layer Component View

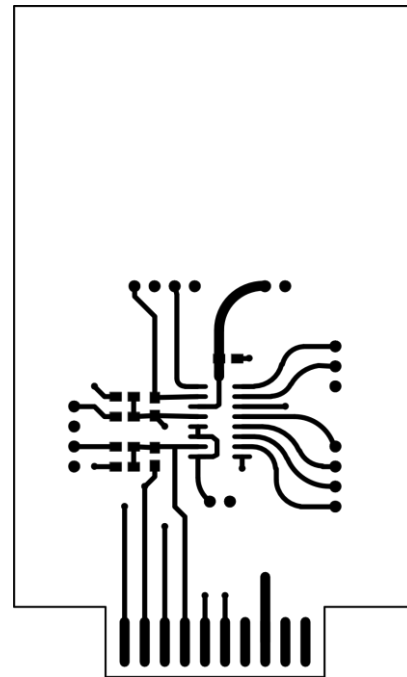

Figure 5. Top Layer Trace View

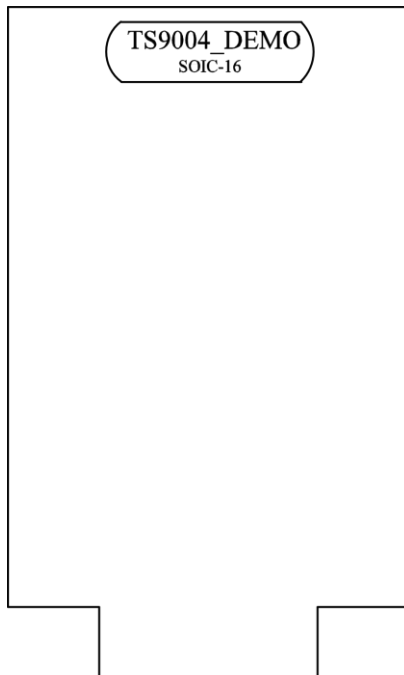

Figure 6. Bottom Layer #1

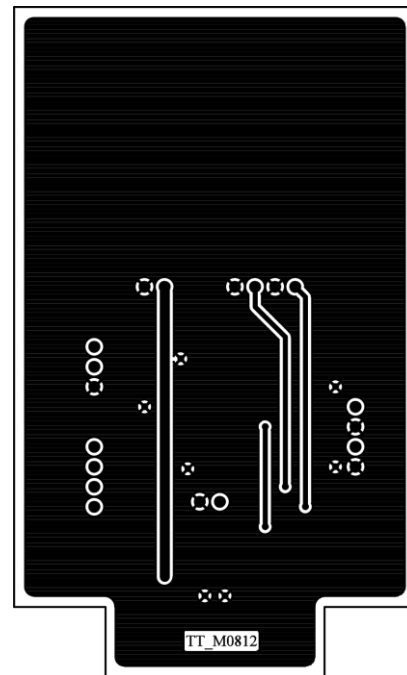

Figure 7. Bottom Layer #2

Компания «Life Electronics» занимается поставками электронных компонентов импортного и отечественного производства от производителей и со складов крупных дистрибьюторов Европы, Америки и Азии.

С конца 2013 года компания активно расширяет линейку поставок компонентов по направлению коаксиальный кабель, кварцевые генераторы и конденсаторы (керамические, пленочные, электролитические), за счёт заключения дистрибьюторских договоров

Мы предлагаем:

- Конкурентоспособные цены и скидки постоянным клиентам.
- Специальные условия для постоянных клиентов.
- Подбор аналогов.
- Поставку компонентов в любых объемах, удовлетворяющих вашим потребностям.
- Приемлемые сроки поставки, возможна ускоренная поставка.
- Доставку товара в любую точку России и стран СНГ.
- Комплексную поставку.
- Работу по проектам и поставку образцов.
- Формирование склада под заказчика.
- Сертификаты соответствия на поставляемую продукцию (по желанию клиента).
- Тестирование поставляемой продукции.
- Поставку компонентов, требующих военную и космическую приемку.
- Входной контроль качества.
- Наличие сертификата ISO.

В составе нашей компании организован Конструкторский отдел, призванный помогать разработчикам, и инженерам.

Конструкторский отдел помогает осуществить:

- Регистрацию проекта у производителя компонентов.
- Техническую поддержку проекта.
- Защиту от снятия компонента с производства.
- Оценку стоимости проекта по компонентам.
- Изготовление тестовой платы монтаж и пусконаладочные работы.



Тел: +7 (812) 336 43 04 (многоканальный)

Email: org@lifeelectronics.ru