

FEATURES

ANALOG I/O

- 8-channel, 247 kSPS, 12-Bit ADC
- DC performance: ± 1 LSB INL
- AC performance: 71 dB SNR
- DMA controller for high speed ADC-to-RAM capture
- 2 12-bit (monotonic) voltage output DACs
- Dual output PWM/ Σ - Δ DACs
- On-chip temperature sensor function: $\pm 3^\circ\text{C}$
- On-chip voltage reference

Memory

- 62 kB on-chip Flash/EE program memory
- 4 kB on-chip Flash/EE data memory
- Flash/EE, 100 Yr retention, 100,000 cycles of endurance
- 2304 bytes on-chip data RAM

8051-based core

- 8051-compatible instruction set (16 MHz maximum)
- 32 kHz external crystal, on-chip programmable PLL
- 12 interrupt sources, 2 priority levels
- Dual data pointer
- Extended 11-bit stack pointer

On-chip peripherals

- Time interval counter (TIC)
- UART, I²C, and SPI Serial I/O
- Watchdog timer (WDT), power supply monitor (PSM)

Power

- Specified for 3 V and 5 V operation
- Normal, idle, and power-down modes
- Power-down: 25 μA @ 3 V with wake-up timer running

APPLICATIONS

Optical networking—laser power control

Base station systems

Precision instrumentation, smart sensors

Transient capture systems

DAS and communications systems

Upgrade to **ADuC812** systems; runs from 32 kHz

External crystal with on-chip PLL.

Also available: **ADuC831** pin-compatible upgrade to existing **ADuC812** systems that require additional code or data memory; runs from 1 MHz to 16 MHz

External crystal

FUNCTIONAL BLOCK DIAGRAM

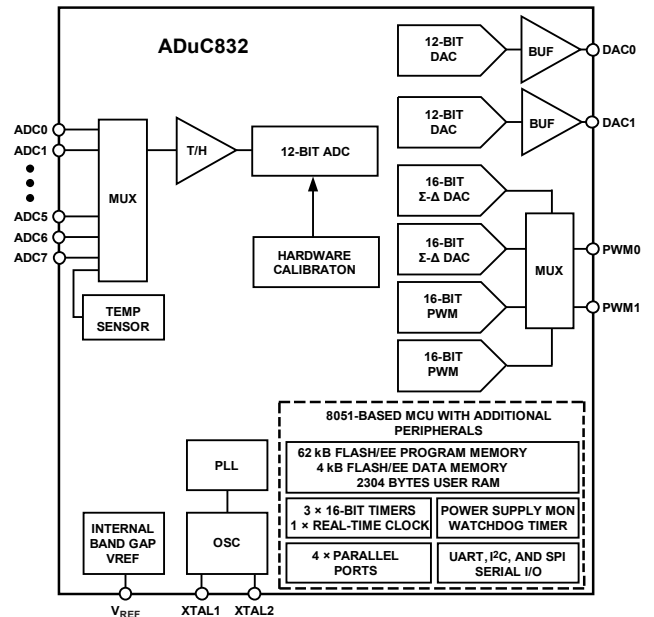

Figure 1.

GENERAL DESCRIPTION

The **ADuC832** is a complete, smart transducer front end, integrating a high performance self-calibrating multichannel 12-bit ADC, dual 12-bit DACs, and programmable 8-bit MCU on a single chip.

The device operates from a 32 kHz crystal with an on-chip PLL, generating a high frequency clock of 16.78 MHz. This clock is, in turn, routed through a programmable clock divider from which the MCU core clock operating frequency is generated. The microcontroller core is an 8052 and is therefore 8051 instruction set compatible with 12 core clock periods per machine cycle. 62 kB of nonvolatile Flash/EE program memory are provided on chip. There are also 4 kB of nonvolatile Flash/EE data memory, 256 bytes of RAM, and 2 kB of extended RAM integrated on chip.

The **ADuC832** also incorporates additional analog functionality with two 12-bit DACs, a power supply monitor, and a band gap reference. On-chip digital peripherals include two 16-bit Σ - Δ DACs, a dual-output 16-bit PWM, a watchdog timer, time interval counter, three timers/counters, Timer 3 for baud rate generation, and serial I/O ports (SPI, I²C®, and UART).

TABLE OF CONTENTS

Features	1	Initiating Calibration in Code	44
Applications	1	Nonvolatile Flash/EE Memory	45
Functional Block Diagram	1	Flash/EE Memory Overview	45
General Description	1	Flash/EE Memory and the ADuC832	45
Revision History	4	ADuC832 Flash/EE Memory Reliability	45
Specifications	6	Using the Flash/EE Program Memory	46
Timing Specifications	10	Flash/EE Program Memory Security	47
Absolute Maximum Ratings	20	Using the Flash/EE Data Memory	48
ESD Caution	20	ECON—Flash/EE Memory Control SFR	48
Pin Configurations and Function Descriptions	21	Example: Programming the Flash/EE Data Memory	49
Typical Performance Characteristics	26	Flash/EE Memory Timing	49
Terminology	29	ADuC832 Configuration SFR (CFG832)	50
ADC Specifications	29	User Interface to Other On-Chip ADuC832 Peripherals	51
DAC Specifications	29	DAC	51
Explanation of Typical Performance Plots	30	Using the DAC	52
Memory Organization	31	On-Chip PLL	54
Flash/EE Program Memory	31	PLLCON (PLL Control Register)	54
Flash/EE Data Memory	31	Pulse-Width Modulator (PWM)	55
General-Purpose RAM	31	PWMCON (PWM Control SFR)	55
External Data Memory (External XRAM)	32	PWM Modes of Operation	56
Internal XRAM	32	Mode 0: PWM Disabled	56
Special Function Registers (SFRs)	33	Mode 1: Single Variable Resolution PWM	56
Accumulator SFR (ACC)	33	Mode 2: Twin 8-Bit PWM	56
B SFR (B)	33	Mode 3: Twin 16-Bit PWM	56
Stack Pointer (SP and SPH)	33	Mode 4: Dual NRZ 16-Bit Σ - Δ DAC	57
Data Pointer (DPTR)	33	Mode 5: Dual 8-Bit PWM	57
Program Status Word (PSW)	33	Mode 6: Dual RZ 16-Bit Σ - Δ DAC	57
Power Control SFR (PCON)	33	Serial Peripheral Interface	58
Special Function Registers	34	MISO (Master Input, Slave Output Data Pin)	58
ADC Circuit Information	35	MOSI (Master Output, Slave Input Pin)	58
General Overview	35	SCLOCK (Serial Clock I/O Pin)	58
ADC Transfer Function	35	\overline{SS} (Slave Select Input Pin)	58
Typical Operation	35	Using the SPI Interface	59
Driving the Analog-to-Digital Converter	39	SPI Interface—Master Mode	59
Voltage Reference Connections	40	SPI Interface—Slave Mode	59
Configuring the ADC	41	I ² C-Compatible Interface	60
ADC DMA Mode	41	I ² C Interface SFRs	60
Micro-Operation During ADC DMA Mode	42	Overview	61
ADC Offset and Gain Calibration Coefficients	42	Software Master Mode	61
Calibrating the ADC	43	Hardware Slave Mode	61

Dual Data Pointers	62	SCON (UART Serial Port Control Register)	75
DPCON (Data Pointer Control SFR)	62	Mode 0: 8-Bit Shift Register Mode	76
Power Supply Monitor	63	Mode 1: 8-Bit UART, Variable Baud Rate.....	76
PSMCON (Power Supply Monitor Control Register)	63	Mode 2: 9-Bit UART with Fixed Baud Rate	76
Watchdog Timer.....	64	Mode 3: 9-Bit UART with Variable Baud Rate.....	76
Time Interval Counter (TIC).....	65	UART Serial Port Baud Rate Generation.....	77
TIMECON (TIC Control Register)	65	Timer 1 Generated Baud Rates	77
INTVAL (User Time Interval Select Register)	66	Timer 2 Generated Baud Rates	77
HTHSEC (Hundredths Seconds Time Register)	66	Timer 3 Generated Baud Rates	78
SEC (Seconds Time Register)	66	Interrupt System.....	80
MIN (Minutes Time Register).....	66	IE (Interrupt Enable Register).....	80
HOUR (Hours Time Register)	66	IP (Interrupt Priority Register)	80
8052-Compatible On-Chip Peripherals	67	IEIP2 (Secondary Interrupt Enable Register)	80
Parallel I/O	67	Interrupt Priority	81
Port 0.....	67	Interrupt Vectors.....	81
Port 1.....	67	ADuC832 Hardware Design Considerations	82
Port 2.....	67	Clock Oscillator.....	82
Port 3.....	68	External Memory Interface.....	82
Additional Digital I/O	68	Power Supplies.....	83
Read-Modify-Write Instructions	69	Power Consumption.....	84
Timers/Counters	70	Power Saving Modes.....	84
Timer/Counter 0 and Timer/Counter 1 Data Registers	71	Power-On Reset.....	84
Timer/Counter 0 And Timer/Counter 1 Operating Modes.....	72	Grounding and Board Layout Recommendations	85
Mode 0 (13-Bit Timer/Counter)	72	Other Hardware Considerations.....	87
Mode 1 (16-Bit Timer/Counter)	72	In-Circuit Serial Download Access	87
Mode 2 (8-Bit Timer/Counter with Autoreload).....	72	Embedded Serial Port Debugger	87
Mode 3 (Two 8-Bit Timer/Counters).....	72	Single-Pin Emulation Mode	87
Timer/Counter 2	73	Typical System Configuration.....	87
T2CON (Timer/Counter 2 Control Register).....	73	Development Tools	88
Timer/Counter 2 Data Registers.....	73	QuickStart Development System.....	88
Timer/Counter Operation Modes	74	QuickStart Plus Development System.....	88
UART Serial Interface.....	75	Outline Dimensions.....	89
SBUF	75	Ordering Guide	89

REVISION HISTORY**5/2016—Rev. B to Rev. C**

Changes to EPAD, Description Column, Table 13.....	21
Updated Outline Dimensions.....	89
Changes to Ordering Guide.....	89

4/2013—Rev. A to Rev. B

Updated Outline Dimensions.....	89
Changes to Ordering Guide.....	89

9/2009—Rev. 0 to Rev. A

Changes to Figure 1.....	1
Changed 16.77 MHz to 16.78 MHz Throughout.....	1
Changes to Reference Input/Output, Output Voltage Parameter, Endnote 19, and Endnote 20, Table 1.....	9
Moved Timing Specifications Section.....	10
Changes to Figure 3.....	10
Changes to Table 3.....	11
Changes to Table 4.....	12
Changes to Table 5.....	13
Changes to Table 11.....	19
Changes to Figure 15 and Table 13.....	21
Changes to Figure 16, Figure 17, Figure 20, and Figure 21.....	26
Added Explanation of Typical Performance Plots Section.....	30
Changes to Flash/EE Program Memory, Flash/EE Data Memory, and General-Purpose RAM Sections.....	31
Changes to Figure 36.....	34
Changes to Figure 39 and Figure 40.....	39
Changes to Table 20.....	40

Changes to A Typical DMA Mode Configuration Example

Section.....	41
Changed 16.777216 MHz to 16.78 MHz Throughout.....	41
Changes to Table 21.....	48
Changes to Using the DAC Section and Figure 52.....	52
Changes to Figure 54 Caption.....	53
Changes to Figure 56.....	55
Changed 16.77 MHz to 16.78 MHz.....	56
Changes to Figure 60.....	57
Changes to Table 31.....	63
Deleted Figure 65 and Figure 66; Renumbered Sequentially ...	66
Deleted ASPIRE—IDE Section.....	66
Deleted Figure 67.....	67
Changes to Table 34.....	67
Changes to Figure 68, Figure 69, Figure 70, and Table 35.....	68
Changes to Figure 84.....	78
Changes to External Memory Interface Section.....	82
Changes to Power Supplies Section.....	83
Changes to Table 50.....	84
Changes to Figure 94.....	86
Changes to Single-Pin Emulation Mode Section.....	87
Changes to QuickStart Development System Section and QuickStart Plus Development System Section.....	88
Updated Outline Dimensions.....	89
Changes to Ordering Guide.....	89

11/2002—Revision 0: Initial Version

On-chip factory firmware supports in-circuit serial download and debug modes (via UART) as well as single-pin emulation mode via the EA pin. The ADuC832 is supported by QuickStart™ and QuickStart Plus development systems featuring low cost software and hardware development tools. A functional block

diagram of the ADuC832 is shown in Figure 1 with a more detailed block diagram shown in Figure 2.

The part is specified for 3 V and 5 V operation over the extended industrial temperature range and is available in a 52-lead metric quad flat package (MQFP) and a 56-lead lead frame chip scale package (LFCSP).



Figure 2. ADuC832 Block Diagram (Shaded Areas are Features Not Present on the ADuC812)

023887-004

SPECIFICATIONS

$AV_{DD} = DV_{DD} = 2.7\text{ V to }3.3\text{ V or }4.5\text{ V to }5.5\text{ V}$; $V_{REF} = 2.5\text{ V}$ internal reference, $f_{CORE} = 16.78\text{ MHz}$; all specifications $T_A = T_{MIN}$ to T_{MAX} , unless otherwise noted.

Table 1.

Parameter ¹	$V_{DD} = 5\text{ V}$	$V_{DD} = 3\text{ V}$	Unit	Test Conditions/Comments
ADC CHANNEL SPECIFICATIONS				
DC Accuracy ^{2,3}				$f_s = 147\text{ kHz}$, see Figure 16 to Figure 21 at other f_s
Resolution	12	12	Bits	
Integral Nonlinearity	± 1	± 1	LSB max	For 2.5 V internal reference
	± 0.3	± 0.3	LSB typ	
Differential Nonlinearity	± 0.9	± 0.9	LSB max	2.5 V internal reference
	± 0.25	± 0.25	LSB typ	
Integral Nonlinearity ⁴	± 1.5	± 1.5	LSB max	1 V external reference
Differential Nonlinearity ⁴	$+1.5/-0.9$	$+1.5/-0.9$	LSB max	1 V external reference
Code Distribution	1	1	LSB typ	ADC input is a dc voltage
Calibrated Endpoint Errors^{5,6}				
Offset Error	± 4	± 4	LSB max	
Offset Error Match	± 1	± 1	LSB typ	
Gain Error	± 2	± 3	LSB max	
Gain Error Match	-85	-85	dB typ	
Dynamic Performance				
Signal-to-Noise Ratio (SNR) ⁷	71	71	dB typ	$f_{IN} = 10\text{ kHz sine wave}$, $f_s = 147\text{ kHz}$
Total Harmonic Distortion (THD)	-85	-85	dB typ	
Peak Harmonic or Spurious Noise	-85	-85	dB typ	
Channel-to-Channel Crosstalk ⁸	-80	-80	dB typ	
Analog Input				
Input Voltage Ranges	0 to V_{REF}	0 to V_{REF}	V	
Leakage Current	± 1	± 1	$\mu\text{A max}$	
Input Capacitance	32	32	pF typ	
Temperature Sensor⁹				
Voltage Output at 25°C	650	650	mV typ	
Voltage TC	-2.0	-2.0	mV/°C typ	
Accuracy	± 3	± 3	°C typ	Internal 2.5 V V_{REF}
	± 1.5	± 1.5	°C typ	External 2.5 V V_{REF}
DAC CHANNEL SPECIFICATIONS, INTERNAL BUFFER ENABLED				
DC Accuracy ¹⁰				DAC load to AGND, $R_L = 10\text{ k}\Omega$, $C_L = 100\text{ pF}$
Resolution	12	12	Bits	
Relative Accuracy	± 3	± 3	LSB typ	
Differential Nonlinearity ¹¹	-1	-1	LSB max	Guaranteed 12-bit monotonic
	$\pm 1/2$	$\pm 1/2$	LSB typ	
Offset Error	± 50	± 50	mV max	V_{REF} range
Gain Error	± 1	± 1	% max	AV_{DD} range
	± 1	± 1	% typ	V_{REF} range
Gain Error Mismatch	0.5	0.5	% typ	% of full scale on DAC1
Analog Outputs				
Voltage Range 0	0 to V_{REF}	0 to V_{REF}	V typ	DAC $V_{REF} = 2.5\text{ V}$
Voltage Range 1	0 to V_{DD}	0 to V_{DD}	V typ	DAC $V_{REF} = V_{DD}$
Output Impedance	0.5	0.5	Ω typ	
DAC AC Characteristics				
Voltage Output Settling Time	15	15	$\mu\text{s typ}$	Full-scale settling time to within $1/2$ LSB of final value
Digital-to-Analog Glitch Energy	10	10	nV sec typ	1 LSB change at major carry

Parameter ¹	V _{DD} = 5 V	V _{DD} = 3 V	Unit	Test Conditions/Comments
DAC CHANNEL SPECIFICATIONS^{12,13}, INTERNAL BUFFER DISABLED				
DC Accuracy ¹⁰				
Resolution	12	12	Bits	
Relative Accuracy	±3	±3	LSB typ	
Differential Nonlinearity ¹¹	-1	-1	LSB max	Guaranteed 12-bit monotonic
	±1/2	±1/2	LSB typ	
Offset Error	±5	±5	mV max	V _{REF} range
Gain Error	-0.3	-0.3	% typ	V _{REF} range
Gain Error Mismatch ⁴	0.5	0.5	% max	% of full scale on DAC1
Analog outputs				
Voltage Range 0	0 to V _{REF}	0 to V _{REF}	V typ	DAC V _{REF} = 2.5 V
REFERENCE INPUT/OUTPUT				
Reference Output ¹⁴				
Output Voltage (V _{REF})	2.5	2.5	V typ	
Accuracy	±2.5	±2.5	% max	Of V _{REF} measured at the C _{REF} pin
Power Supply Rejection	47	47	dB typ	
Reference Temperature Coefficient	±100	±100	ppm/°C typ	
Internal V _{REF} Power-On Time	80	80	ms typ	
External Reference Input ¹⁵				V _{REF} and C _{REF} pins shorted
Voltage Range (V _{REF}) ⁴	0.1	0.1	V min	
	V _{DD}	V _{DD}	V max	
Input Impedance	20	20	kΩ typ	
Input Leakage	1	1	μA max	Internal band gap deselected via ADCCON1[6]
POWER SUPPLY MONITOR (PSM)				
DV _{DD} Trip Point Selection Range	2.63		V min	
	4.37		V max	Four trip points selectable in this range programmed via TPD1 and TPD0 in PSMCON
DV _{DD} Power Supply Trip Point Accuracy	±3.5		% max	
WATCHDOG TIMER (WDT)⁴				
Timeout Period	0	0	ms min	Nine timeout periods
	2000	2000	ms max	Selectable in this range
FLASH/EE MEMORY RELIABILITY CHARACTERISTICS¹⁶				
Endurance ¹⁷	100,000	100,000	Cycles min	
Data Retention ¹⁸	100	100	Years min	
DIGITAL INPUTS				
Input High Voltage (V _{INH}) ⁴	2.4	2	V min	
Input Low Voltage (V _{INL}) ⁴	0.8	0.4	V max	
Input Leakage Current (Port 0, \overline{EA})	±10	±10	μA max	V _{IN} = 0 V or V _{DD}
	±1	±1	μA typ	V _{IN} = 0 V or V _{DD}
Logic 1 Input Current (All Digital Inputs)	±10	±10	μA max	V _{IN} = V _{DD}
	±1	±1	μA typ	V _{IN} = V _{DD}
Logic 0 Input Current (Port 1, Port 2, and Port 3)	-75	-25	μA max	
	-40	-15	μA typ	V _{IL} = 450 mV
Logic 1-to-Logic 0 Transition Current (Port 2, Port 3)	-660	-250	μA max	V _{IL} = 2 V
	-400	-140	μA typ	V _{IL} = 2 V

Parameter ¹	V _{DD} = 5 V	V _{DD} = 3 V	Unit	Test Conditions/Comments
SCLOCK and RESET ONLY⁴ (Schmitt-Triggered Inputs)				
V _{T+}	1.3	0.95	V min	
	3.0	2.5	V max	
V _{T-}	0.8	0.4	V min	
	1.4	1.1	V max	
V _{T+} – V _{T-}	0.3	0.3	V min	
	0.85	0.85	V max	
CRYSTAL OSCILLATOR				
Logic Inputs, XTAL1 Only				
V _{INL} , Input Low Voltage	0.8	0.4	V typ	
V _{INH} , Input High Voltage	3.5	2.5	V typ	
XTAL1 Input Capacitance	18	18	pF typ	
XTAL2 Output Capacitance	18	18	pF typ	
MCU CLOCK RATE	16.78	16.78	MHz max	Programmable via PLLCON[2:0]
DIGITAL OUTPUTS				
Output High Voltage (V _{OH})				
	2.4		V min	V _{DD} = 4.5 V to 5.5 V
	4.0		V typ	I _{SOURCE} = 80 μA
		2.4	V min	V _{DD} = 2.7 V to 3.3 V
		2.6	V typ	I _{SOURCE} = 20 μA
Output Low Voltage (V _{OL})				
ALE, Port 0 and Port 2				
	0.4	0.4	V max	I _{SINK} = 1.6 mA
	0.2	0.2	V typ	I _{SINK} = 1.6 mA
Port 3				
	0.4	0.4	V max	I _{SINK} = 4 mA
SCLOCK/SDATA				
	0.4	0.4	V max	I _{SINK} = 8 mA, I ² C enabled
Floating State Leakage Current ⁴				
	±10	±10	μA max	
	±1	±1	μA typ	
Floating State Output Capacitance				
	10	10	pF typ	
START-UP TIME				
At Power-On				
	500	500	ms typ	At any Core_CLK
From Idle Mode				
	100	100	μs typ	
From Power-Down Mode				
Wakeup with INT0 Interrupt				
	150	400	μs typ	
Wakeup with SPI/I ² C Interrupt				
	150	400	μs typ	
Wakeup with External Reset				
	150	400	μs typ	
After External Reset in Normal Mode				
	30	30	ms typ	
After WDT Reset in Normal Mode				
	3	3	ms typ	Controlled via WDCON SFR
POWER REQUIREMENTS^{19, 20}				
Power Supply Voltages				
AV _{DD} /DV _{DD} – AGND				
		2.7	V min	AV _{DD} /DV _{DD} = 3 V nom
		3.3	V max	
	4.5		V min	AV _{DD} /DV _{DD} = 5 V nom
	5.5		V max	
Power Supply Currents Normal Mode				
DV _{DD} Current ⁴				
	6	3	mA max	Core_CLK = 2.097 MHz
AV _{DD} Current				
	1.7	1.7	mA max	Core_CLK = 2.097 MHz
DV _{DD} Current				
	23	12	mA max	Core_CLK = 16.78 MHz
	20	10	mA typ	Core_CLK = 16.78 MHz
AV _{DD} Current				
	1.7	1.7	mA max	Core_CLK = 16.78 MHz
Power Supply Currents Idle Mode				
DV _{DD} Current				
	4	2	mA typ	Core_CLK = 2.097 MHz
AV _{DD} Current				
	0.14	0.14	mA typ	Core_CLK = 2.097 MHz
DV _{DD} Current ⁴				
	10	5	mA max	Core_CLK = 16.78 MHz
	9	4	mA typ	Core_CLK = 16.78 MHz
AV _{DD} Current				
	0.14	0.14	mA typ	Core_CLK = 16.78 MHz

Parameter ¹	V _{DD} = 5 V	V _{DD} = 3 V	Unit	Test Conditions/Comments
Power Supply Currents Power-Down Mode				Core_CLK = 2.097 MHz or 16.78 MHz
DV _{DD} Current ⁴	80	25	μA max	Oscillator on
	38	14	μA typ	
AV _{DD} Current	2	1	μA typ	
DV _{DD} Current	35	20	μA max	Oscillator off
	25	12	μA typ	
Typical Additional Power Supply Currents				AV _{DD} = DV _{DD} = 5 V
PSM Peripheral	50		μA typ	
ADC	1.5		mA typ	
DAC	150		μA typ	

¹ Temperature range: -40°C to +125°C.

² ADC linearity is guaranteed during normal MicroConverter core operation.

³ ADC LSB size = $V_{REF}/2^{12}$, that is, for internal $V_{REF} = 2.5$ V, 1 LSB = 610 μV and for external $V_{REF} = 1$ V, 1 LSB = 244 μV.

⁴ Not production tested, but are guaranteed by design and/or characterization data on production release.

⁵ Offset error, gain error, offset error match, and gain error match are measured after factory calibration.

⁶ Based on external ADC system components, the user may need to execute a system calibration to remove additional external channel errors and achieve these specifications.

⁷ SNR calculation includes distortion and noise components.

⁸ Channel-to-channel crosstalk is measured on adjacent channels.

⁹ The temperature sensor gives a measure of the die temperature directly; air temperature can be inferred from this result.

¹⁰ DAC linearity is calculated using:

Reduced code range of 100 to 4095, 0 V to V_{REF} range.

Reduced code range of 100 to 3945, 0 V to V_{DD} range.

DAC output load = 10 kΩ and 100 pF.

¹¹ DAC differential nonlinearity specified on 0 V to V_{REF} and 0 V to V_{DD} ranges.

¹² DAC specification for output impedance in the unbuffered case depends on DAC code.

¹³ DAC specifications for I_{SINK} , voltage output settling time, and digital-to-analog glitch energy depend on external buffer implementation in unbuffered mode. DAC in unbuffered mode tested with OP270 external buffer, which has a low input leakage current.

¹⁴ Measured with V_{REF} and C_{REF} pins decoupled with 0.1 μF capacitors to ground. Power-up time for the internal reference is determined by the value of the decoupling capacitor chosen for both the V_{REF} and C_{REF} pins.

¹⁵ When using an external reference device, the internal band gap reference input can be bypassed by setting the ADCCON1[6] bit. In this mode, the V_{REF} and C_{REF} pins need to be shorted together for correct operation.

¹⁶ Flash/EE Memory reliability characteristics apply to both the Flash/EE program memory and the Flash/EE data memory.

¹⁷ Endurance is qualified to 100,000 cycles as per JEDEC Std. 22 method A117 and measured at -40°C, +25°C, and +125°C. Typical endurance at 25°C is 700,000 cycles.

¹⁸ Retention lifetime equivalent at junction temperature (T_j) = 55°C as per JEDEC Std. 22 Method A117. Retention lifetime based on an activation energy of 0.6 eV derates with junction temperature as shown in Figure 48 in the ADuC832 Flash/EE Memory Reliability section.

¹⁹ Power supply current consumption is measured in normal, idle, and power-down modes under the following conditions:

Normal mode: RESET = 0.4 V, digital I/O pins = open circuit, Core_CLK changed via the CD bits in PLLCON[2:0], core executing internal software loop.

Idle mode: RESET = 0.4 V, digital I/O pins = open circuit, Core_CLK changed via the CD bits in PLLCON, PCON[0] = 1, core execution suspended in idle mode.

Power-down mode: RESET = 0.4 V, all Port 0 pins = 0.4 V, all other digital I/O and Port 1 pins are open circuit, Core_CLK changed via the CD bits in PLLCON, PCON[1] = 1, core execution suspended in power-down mode, oscillator turned on or off via OSC_PD bit (PLLCON[7]).

²⁰ DV_{DD} power supply current increases typically by 3 mA (3 V operation) and 10 mA (5 V operation) during a Flash/EE memory program or erase cycle.

TIMING SPECIFICATIONS

$AV_{DD} = 2.7\text{ V to }3.6\text{ V or }4.75\text{ V to }5.25\text{ V}$, $DV_{DD} = 2.7\text{ V to }3.6\text{ V or }4.75\text{ V to }5.25\text{ V}$; all specifications T_{MIN} to T_{MAX} , unless otherwise noted.

Table 2. Clock Input (External Clock Applied on XTAL1)

Parameter ^{1, 2, 3}	Description	32.768 kHz External Crystal			Unit
		Min	Typ	Max	
t_{CK}	XTAL1 period (see Figure 3)		30.52		μs
t_{CKL}	XTAL1 width low (see Figure 3)		15.16		μs
t_{CKH}	XTAL1 width high (see Figure 3)		15.16		μs
t_{CKR}	XTAL1 rise time (see Figure 3)		20		ns
t_{CKF}	XTAL1 fall time (see Figure 3)		20		ns
$1/t_{CORE}$	ADuC832 core clock frequency ⁴	0.131		16.78	MHz
t_{CORE}	ADuC832 core clock period ⁵		0.476		μs
t_{CYC}	ADuC832 machine cycle time ⁶	0.72	5.7	91.55	μs

¹ AC inputs during testing are driven at $DV_{DD} - 0.5\text{ V}$ for a Logic 1 and 0.45 V for a Logic 0. Timing measurements are made at V_{IH} minimum for a Logic 1 and V_{IL} maximum for a Logic 0, as shown in Figure 4.

² For timing purposes, a port pin is no longer floating when a 100 mV change from load voltage occurs. A port pin begins to float when a 100 mV change from the loaded V_{OH}/V_{OL} level occurs, as shown in Figure 4.

³ C_{LOAD} for all outputs = 80 pF, unless otherwise noted.

⁴ The ADuC832 internal PLL locks onto a multiple (512 times) the external crystal frequency of 32.768 kHz to provide a stable 16.78 MHz internal clock for the system. The core can operate at this frequency or at a binary submultiple called Core_CLK, selected via the PLLCON SFR.

⁵ This number is measured at the default Core_CLK operating frequency of 2.09 MHz.

⁶ ADuC832 machine cycle time is nominally defined as $12/\text{Core_CLK}$.

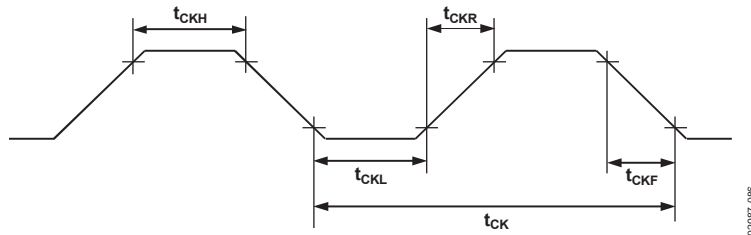

Figure 3. XTAL1 Input



Figure 4. Timing Waveform Characteristics

Table 3. External Program Memory Read Cycle

Parameter ¹	Description	16.78 MHz Core_CLK		Variable Clock		Unit
		Min	Max	Min	Max	
t _{LHLL}	ALE pulse width	79		2t _{CK} - 40		ns
t _{AVLL}	Address valid to ALE low	19		t _{CK} - 40		ns
t _{LLAX}	Address hold after ALE low	29		t _{CK} - 30		ns
t _{LLIV}	ALE low to valid instruction in		138		4t _{CK} - 100	ns
t _{LLPL}	ALE low to PSEN low	29		t _{CK} - 30		ns
t _{PLPH}	PSEN pulse width	133		3t _{CK} - 45		ns
t _{PLIV}	PSEN low to valid instruction in		73		3t _{CK} - 105	ns
t _{PXIX}	Instruction in, hold after PSEN	0		0		ns
t _{PXIZ}	Instruction in, float after PSEN		34		t _{CK} - 25	ns
t _{AVIV}	Address to valid instruction in		193		5t _{CK} - 105	ns
t _{PLAZ}	PSEN low to address float		25		25	ns
t _{PHAX}	Address hold after PSEN high	0		0		ns

¹ See Figure 5.

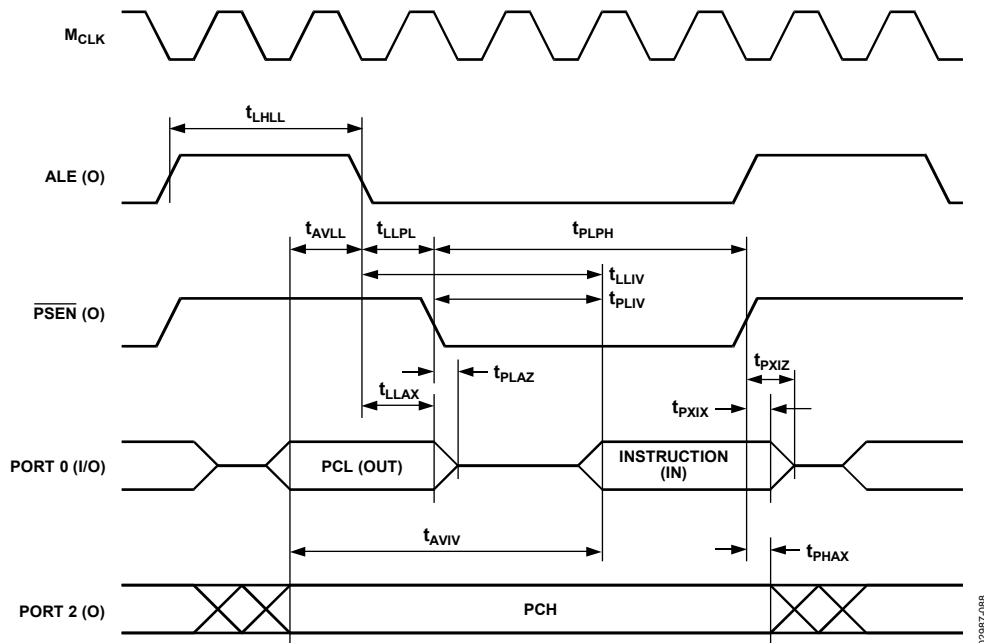

Figure 5. External Program Memory Read Cycle

Table 4. External Data Memory Read Cycle

Parameter ¹	Description	16.78 MHz Core_CLK		Variable Clock		Unit
		Min	Max	Min	Max	
t_{RLRH}	\overline{RD} pulse width	257		$6t_{CK} - 100$		ns
t_{AVLL}	Address valid before ALE low	19		$t_{CK} - 40$		ns
t_{LLAX}	Address hold after ALE low	24		$t_{CK} - 35$		ns
t_{RLDV}	\overline{RD} low to valid data in		133		$5t_{CK} - 165$	ns
t_{RHDX}	Data and address hold after \overline{RD}	0		0		ns
t_{RHDZ}	Data float after \overline{RD}		49		$2t_{CK} - 70$	ns
t_{LLDV}	ALE low to valid data in		326		$8t_{CK} - 150$	ns
t_{AVDV}	Address to valid data in		371		$9t_{CK} - 165$	ns
t_{LLWL}	ALE low to \overline{RD} low	128	228	$3t_{CK} - 50$	$3t_{CK} + 50$	ns
t_{AVWL}	Address valid to \overline{RD} low	108		$4t_{CK} - 130$		ns
t_{RLAZ}	\overline{RD} low to address float	0		0		ns
t_{WHLH}	\overline{RD} high to ALE high	19	257	$t_{CK} - 40$	$6t_{CK} - 100$	ns

¹ See Figure 6.



Figure 6. External Data Memory Read Cycle

Table 5. External Data Memory Write Cycle

Parameter ¹	Description	16.78 MHz Core_CLK		Variable Clock		Unit
		Min	Max	Min	Max	
t _{WLWH}	WR pulse width	257		6t _{CK} - 100		ns
t _{AVLL}	Address valid before ALE low	19		t _{CK} - 40		ns
t _{LLAX}	Address hold after ALE low	24		t _{CK} - 35		ns
t _{LLWL}	ALE low to \overline{WR} low	128	228	3t _{CK} - 50	3t _{CK} + 50	ns
t _{AVWL}	Address valid to \overline{WR} Low	108		4t _{CK} - 130		ns
t _{QVWX}	Data valid to \overline{WR} transition	9		t _{CK} - 50		ns
t _{QVWH}	Data setup before \overline{WR}	267		7t _{CK} - 150		ns
t _{WHQX}	Data and address hold after \overline{WR}	9		t _{CK} - 50		ns
t _{WHLH}	\overline{WR} high to ALE high	19	257	t _{CK} - 40	6t _{CK} - 100	ns

¹ See Figure 7.



Figure 7. External Data Memory Write Cycle

Table 6. UART Timing (Shift Register Mode)

Parameter ¹	Description	16.78 MHz Core_CLK			Variable Clock			Unit
		Min	Typ	Max	Min	Typ	Max	
t_{XLXL}	Serial port clock cycle time		715			$12t_{CK}$		μs
t_{QVXH}	Output data setup to clock	463			$10t_{CK} - 133$			ns
t_{DVXH}	Input data setup to clock	252			$2t_{CK} + 133$			ns
t_{XHDX}	Input data hold after clock	0			0			ns
t_{XHGX}	Output data hold after clock	22			$2t_{CK} - 117$			ns

¹ See Figure 8.



Figure 8. UART Timing in Shift Register Mode

02387-091

Table 7. I²C-Compatible Interface Timing

Parameter ¹	Description	Min	Max	Unit
t _L	SCLOCK low pulse width	4.7		μs
t _H	SCLOCK high pulse width	4.0		μs
t _{SHD}	Start condition hold time	0.6		μs
t _{DSU}	Data setup time	100		μs
t _{DHD}	Data hold time		0.9	μs
t _{RSU}	Setup time for repeated start	0.6		μs
t _{PSU}	Stop condition setup time	0.6		μs
t _{BUF}	Bus free time between a stop condition and a start condition	1.3		μs
t _R	Rise time of both SCLOCK and SDATA		300	ns
t _F	Fall time of both SCLOCK and SDATA		300	ns
t _{SUP} ²	Pulse width of spike suppressed		50	ns

¹ See Figure 9.

² Input filtering on both the SCLOCK and SDATA inputs suppresses noise spikes less than 50 ns.



Figure 9. I²C Compatible Interface Timing

Table 8. SPI Master Mode Timing (CPHA = 1)

Parameter ¹	Description	Min	Typ	Max	Unit
t_{SL}	SCLOCK low pulse width ²		476		ns
t_{SH}	SCLOCK high pulse width ²		476		ns
t_{DAV}	Data output valid after SCLOCK edge			50	ns
t_{DSU}	Data input setup time before SCLOCK edge	100			ns
t_{DHD}	Data input hold time after SCLOCK edge	100			ns
t_{DF}	Data output fall time		10	25	ns
t_{DR}	Data output rise time		10	25	ns
t_{SR}	SCLOCK rise time		10	25	ns
t_{SF}	SCLOCK fall time		10	25	ns

¹ See Figure 10.

² Characterized under the following conditions:

- a. Core clock divider bits (CD2, CD1, and CD0 bits in PLLCON SFR) set to 0, 1, and 1, respectively, that is, core clock frequency = 2.09 MHz
- b. SPI bit rate selection bits (SPR1 and SPR0 bits in SPICON SFR) set to 0 and 0, respectively.



Figure 10. SPI Master Mode Timing (CPHA = 1)

02987-093

Table 9. SPI Master Mode Timing (CPHA = 0)

Parameter ¹	Description	Min	Typ	Max	Unit
t _{SL}	SCLOCK low pulse width ²		476		ns
t _{SH}	SCLOCK high pulse width ²		476		ns
t _{DAV}	Data output valid after SCLOCK edge			50	ns
t _{DOSU}	Data output setup before SCLOCK edge			150	ns
t _{DSU}	Data input setup time before SCLOCK edge	100			ns
t _{DHD}	Data input hold time after SCLOCK edge	100			ns
t _{DF}	Data output fall time		10	25	ns
t _{DR}	Data output rise time		10	25	ns
t _{SR}	SCLOCK rise time		10	25	ns
t _{SF}	SCLOCK fall time		10	25	ns

¹ See Figure 11.

² Characterized under the following conditions:

- a. Core clock divider bits (CD2, CD1, and CD0 bits in PLLCON SFR) set to 0, 1, and 1, respectively, that is, core clock frequency = 2.09 MHz
- b. SPI bit rate selection bits (SPR1 and SPR0 bits in SPICON SFR) set to 0 and 0, respectively.

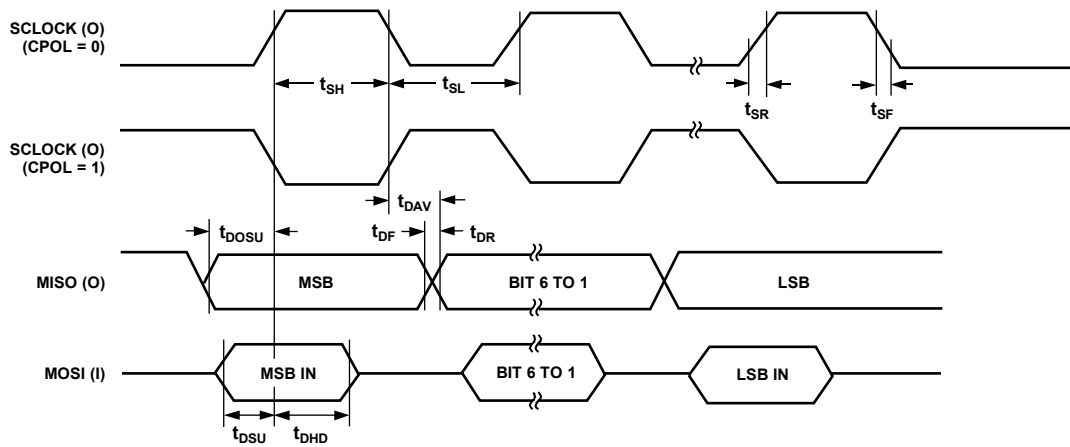

Figure 11. SPI Master Mode Timing (CPHA = 0)

02987-094

Table 10. SPI Slave Mode Timing (CPHA = 1)

Parameter ¹	Description	Min	Typ	Max	Unit
t_{SS}	\overline{SS} to SCLOCK edge	0			ns
t_{SL}	SCLOCK low pulse width		330		ns
t_{SH}	SCLOCK high pulse width		330		ns
t_{DAV}	Data output valid after SCLOCK edge			50	ns
t_{DSU}	Data input setup time before SCLOCK edge	100			ns
t_{DHD}	Data input hold time after SCLOCK edge	100			ns
t_{DF}	Data output fall time		10	25	ns
t_{DR}	Data output rise time		10	25	ns
t_{SR}	SCLOCK rise time		10	25	ns
t_{SF}	SCLOCK fall time		10	25	ns
t_{SFS}	\overline{SS} high after SCLOCK edge	0			ns

¹ See Figure 12.



Figure 12. SPI Slave Mode Timing (CPHA = 1)

02987-095

Table 11. SPI Slave Mode Timing (CPHA = 0)

Parameter ¹	Description	Min	Typ	Max	Unit
t _{SS}	\overline{SS} to SCLOCK edge	0			ns
t _{SL}	SCLOCK low pulse width		330		ns
t _{SH}	SCLOCK high pulse width		330		ns
t _{DAV}	Data output valid after SCLOCK edge			50	ns
t _{DSU}	Data input setup time before SCLOCK edge	100			ns
t _{DHD}	Data input hold time after SCLOCK edge	100			ns
t _{DF}	Data output fall time		10	25	ns
t _{DR}	Data output rise time		10	25	ns
t _{SR}	SCLOCK rise time		10	25	ns
t _{SF}	SCLOCK fall time		10	25	ns
t _{DOSS}	Data output valid after \overline{SS} edge			20	ns
t _{SFS}	\overline{SS} high after SCLOCK edge	0			ns

¹ See Figure 13.



Figure 13. SPI Slave Mode Timing (CPHA = 0)

02987-096

ABSOLUTE MAXIMUM RATINGS

$T_A = 25^\circ\text{C}$, unless otherwise noted.

Table 12.

Parameter	Rating
AV_{DD} to DV_{DD}	-0.3 V to +0.3 V
AGND to DGND	-0.3 V to +0.3 V
DV_{DD} to DGND, AV_{DD} to AGND	-0.3 V to +7 V
Digital Input Voltage to DGND	-0.3 V to $DV_{DD} + 0.3$ V
Digital Output Voltage to DGND	-0.3 V to $DV_{DD} + 0.3$ V
V_{REF} to AGND	-0.3 V to $AV_{DD} + 0.3$ V
Analog Inputs to AGND	-0.3 V to $AV_{DD} + 0.3$ V
Operating Temperature Range Industrial ADuC832BSZ	-40°C to +125°C
Operating Temperature Range Industrial ADuC832BCPZ	-40°C to +85°C
Storage Temperature Range	-65°C to +150°C
Junction Temperature	150°C
θ_{JA} Thermal Impedance (ADuC832BSZ)	90°C/W
θ_{JA} Thermal Impedance (ADuC832BCPZ)	52°C/W
Lead Temperature, Soldering	
Vapor Phase (60 sec)	215°C
Infrared (15 sec)	220°C

Stresses at or above those listed under Absolute Maximum Ratings may cause permanent damage to the product. This is a stress rating only; functional operation of the product at these or any other conditions above those indicated in the operational section of this specification is not implied. Operation beyond the maximum operating conditions for extended periods may affect product reliability.

ESD CAUTION



ESD (electrostatic discharge) sensitive device.

Charged devices and circuit boards can discharge without detection. Although this product features patented or proprietary protection circuitry, damage may occur on devices subjected to high energy ESD. Therefore, proper ESD precautions should be taken to avoid performance degradation or loss of functionality.

PIN CONFIGURATIONS AND FUNCTION DESCRIPTIONS

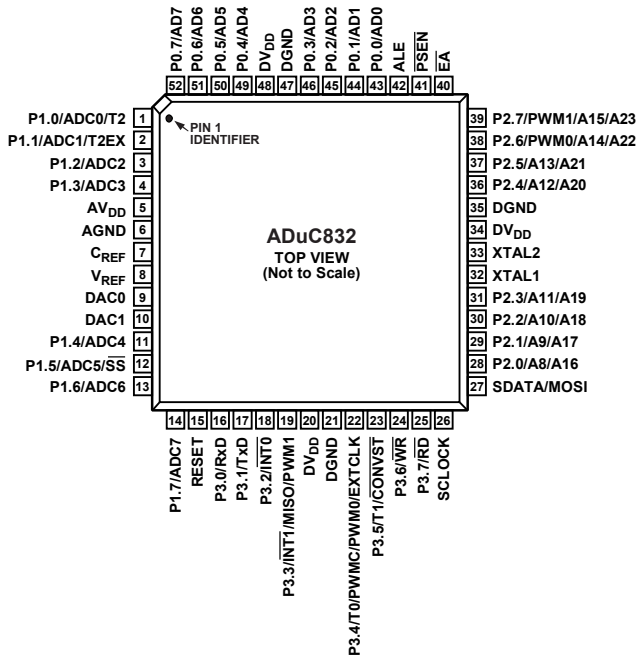

Figure 14. 52-Lead MQFP



Figure 15. 56-Lead LFCSP

NOTES
 1. THE LFCSP HAS AN EXPOSED PADDLE THAT MUST BE SOLDERED TO THE PCB BUT ELECTRICALLY LEFT UNCONNECTED.

Table 13. Pin Function Descriptions

Mnemonic	Pin No.		Type	Description
	MQFP	LFCSP		
EPAD	N/A ¹	0		Exposed Pad. The LFCSP has an exposed paddle that must be soldered to the PCB but electrically left unconnected.
P1.0/ADC0/T2	1	56	I	Input Port 1 (P1.0). Port 1 is an 8-bit input port only. Unlike other ports, Port 1 defaults to analog input mode. To configure any Port 1 pin as a digital input, write a 0 to the Port 1 bit. Port 1 pins are multifunctional and share the following functionality. I Single-Ended Analog Input (ADC0). Channel selection is via ADCCON2 SFR. I Timer/Counter 2 Digital Input (T2). When enabled, Counter 2 is incremented in response to a 1-to-0 transition of the T2 input.
P1.1/ADC1/T2EX	2	1	I	Input Port 1 (P1.1). Port 1 is an 8-bit input port only. Unlike other ports, Port 1 defaults to analog input mode. To configure any Port 1 pin as a digital input, write a 0 to the Port 1 bit. Port 1 pins are multifunctional and share the following functionality. I Single-Ended Analog Input (ADC1). Channel selection is via ADCCON2 SFR. I Digital Input (T2EX). Capture/Reload trigger for Counter 2; also functions as an up/down control input for Counter 2.
P1.2/ADC2	3	2	I	Input Port 1 (P1.2). Port 1 is an 8-bit input port only. Unlike other ports, Port 1 defaults to analog input mode. To configure any Port 1 pin as a digital input, write a 0 to the Port 1 bit. Port 1 pins are multifunctional and share the following functionality. I Single-Ended Analog Input (ADC2). Channel selection is via ADCCON2 SFR.
P1.3/ADC3	4	3	I	Input Port 1 (P1.3). Port 1 is an 8-bit input port only. Unlike other ports, Port 1 defaults to analog input mode. To configure any Port 1 pin as a digital input, write a 0 to the Port 1 bit. Port 1 pins are multifunctional and share the following functionality. I Single-Ended Analog Input (ADC3). Channel selection is via ADCCON2 SFR.
AV _{DD}	5	4, 5	P	Analog Positive Supply Voltage, 3 V or 5 V Nominal.
AGND	6	6, 7, 8	G	Analog Ground. Ground reference point for the analog circuitry.
C _{REF}	7	9	I/O	Decoupling Input for On-Chip Reference. Connect 0.1 μF between this pin and AGND.

Mnemonic	Pin No.		Type	Description
	MQFP	LFCSP		
V _{REF}	8	10	I/O	Reference Input/Output. This pin is connected to the internal reference through a series resistor and is the reference source for the analog-to-digital converter. The nominal internal reference voltage is 2.5 V, which appears at the pin. See the Voltage Reference Connections section on how to connect an external reference.
DAC0	9	11	O	Voltage Output from DAC0.
DAC1	10	12	O	Voltage Output from DAC1.
P1.4/ADC4	11	13	I	Input Port 1 (P1.4). Port 1 is an 8-bit input port only. Unlike other ports, Port 1 defaults to analog input mode. To configure any Port 1 pin as a digital input, write a 0 to the Port 1 bit. Port 1 pins are multifunctional and share the following functionality. Single-Ended Analog Input (ADC4). Channel selection is via ADCCON2 SFR.
P1.5/ADC5/ \overline{SS}	12	14	I	Input Port 1 (P1.5). Port 1 is an 8-bit input port only. Unlike other ports, Port 1 defaults to analog input mode. To configure any of these Port Pins as a digital input, write a 0 to the port bit. Port 1 pins are multifunction and share the following functionality. Single-Ended Analog Input (ADC5). Channel selection is via ADCCON2 SFR.
P1.6/ADC6	13	15	I	Input Port 1 (P1.6). Port 1 is an 8-bit input port only. Unlike other ports, Port 1 defaults to analog input mode. To configure any Port 1 pin as a digital input, write a 0 to the Port 1 bit. Port 1 pins are multifunctional and share the following functionality. Single-Ended Analog Input (ADC6). Channel selection is via ADCCON2 SFR.
P1.7/ADC7	14	16	I	Input Port 1 (P1.7). Port 1 is an 8-bit input port only. Unlike other ports, Port 1 defaults to Analog Input mode. To configure any Port 1 pin as a digital input, write a 0 to the Port 1 bit. Port 1 pins are multifunctional and share the following functionality. Single-Ended Analog Input (ADC7). Channel selection is via ADCCON2 SFR.
RESET	15	17	I	Digital Input. A high level on this pin for 24 master clock cycles while the oscillator is running resets the device.
P3.0/RxD	16	18	I/O	Input/Output Port 3 (P3.0). Port 3 is a bidirectional port with internal pull-up resistors. Port 3 pins that have 1s written to them are pulled high by the internal pull-up resistors, and in that state can be used as inputs. As inputs, Port 3 pins being pulled externally low sources current because of the internal pull-up resistors. Receiver Data Input (Asynchronous) or Data Input/Output (Synchronous) of Serial (UART) Port (RxD).
P3.1/TxD	17	19	I/O	Input/Output Port 3 (P3.1). Port 3 is a bidirectional port with internal pull-up resistors. Port 3 pins that have 1s written to them are pulled high by the internal pull-up resistors, and in that state can be used as inputs. As inputs, Port 3 pins being pulled externally low sources current because of the internal pull-up resistors. Transmitter Data Output (Asynchronous) or Clock Output (Synchronous) of Serial (UART) Port (TxD).
P3.2/ $\overline{INT0}$	18	20	I	Input/Output Port 3 (P3.2). Port 3 is a bidirectional port with internal pull-up resistors. Port 3 pins that have 1s written to them are pulled high by the internal pull-up resistors, and in that state can be used as inputs. As inputs, Port 3 pins being pulled externally low sources current because of the internal pull-up resistors. Interrupt 0 ($\overline{INT0}$). This programmable edge or level triggered interrupt input can be programmed to one of two priority levels. This pin can also be used as a gate control input to Timer 0.
P3.3/ $\overline{INT1}$ /MISO/PWM1	19	21	I	Input/Output Port 3 (P3.3). Port 3 is a bidirectional port with internal pull-up resistors. Port 3 pins that have 1s written to them are pulled high by the internal pull-up resistors, and in that state can be used as inputs. As inputs, Port 3 pins being pulled externally low sources current because of the internal pull-up resistors. Interrupt 1 ($\overline{INT1}$). This programmable edge or level triggered interrupt input can be programmed to one of two priority levels. This pin can also be used as a gate control input to Timer 1.
DV _{DD}	20, 34, 48	22, 36, 51	P	SPI Master Input/Slave Output Data I/O Pin for SPI Serial Interface (MISO). PWM1 Voltage Output (PWM1). See the ADuC832 Configuration SFR (CFG832) section for further information. Digital Positive Supply Voltage, 3 V or 5 V Nominal.
DGND	21, 35, 47	23, 37, 38, 50	G	Digital Ground. Ground reference point for the digital circuitry.

Mnemonic	Pin No.		Type	Description
	MQFP	LFCSP		
P3.4/T0/PWMC/PWM0/EXTCLK	22	24	I/O I I O I	Input/Output Port 3 (P3.4). Port 3 is a bidirectional port with internal pull-up resistors. Port 3 pins that have 1s written to them are pulled high by the internal pull-up resistors, and in that state can be used as inputs. As inputs, Port 3 pins being pulled externally low sources current because of the internal pull-up resistors. Timer/Counter 0 Input (T0). PWM Clock Input (PWMC). PWM0 Voltage Output (PWM0). PWM outputs can be configured to uses Port 2.6 and Port 2.7, or Port 3.4 and Port 3.3. Input for External Clock Signal (EXTCLK). This pin must be enabled via the CFG832 register.
P3.5/T1/ $\overline{\text{CONVST}}$	23	25	I/O I I	Input/Output Port 3 (P3.5). Port 3 is a bidirectional port with internal pull-up resistors. Port 3 pins that have 1s written to them are pulled high by the internal pull-up resistors, and in that state can be used as inputs. As inputs, Port 3 pins being pulled externally low sources current because of the internal pull-up resistors. Timer/Counter 1 Input (T1). Active Low Convert Start Logic Input for the ADC Block When the External Convert Start Function is Enabled ($\overline{\text{CONVST}}$). A low-to-high transition on this input puts the track-and-hold into its hold mode and starts conversion.
P3.6/ $\overline{\text{WR}}$	24	26	I/O O	Input/Output Port 3 (P3.6). Port 3 is a bidirectional port with internal pull-up resistors. Port 3 pins that have 1s written to them are pulled high by the internal pull-up resistors, and in that state can be used as inputs. As inputs, Port 3 pins being pulled externally low sources current because of the internal pull-up resistors. Write Control Signal, Logic Output ($\overline{\text{WR}}$). Latches the data byte from Port 0 into the external data memory.
P3.7/ $\overline{\text{RD}}$	25	27	O O	Input/Output Port 3 (P3.7). Port 3 is a bidirectional port with internal pull-up resistors. Port 3 pins that have 1s written to them are pulled high by the internal pull-up resistors, and in that state can be used as inputs. As inputs, Port 3 pins being pulled externally low sources current because of the internal pull-up resistors. Read Control Signal, Logic Output ($\overline{\text{RD}}$). Enables the external data memory to Port 0.
SCLOCK	26	28	I/O	Serial Clock Pin for I ² C-Compatible or SPI Serial Interface Clock.
SDATA/MOSI	27	29	I/O I/O	User Selectable, I ² C-Compatible or SPI Data Input/Output Pin (SDATA). SPI Master Output/Slave Input Data I/O Pin for SPI Interface (MOSI).
P2.0/A8/A16	28	30	I/O I/O	Input/Output Port 2 (P2.0). Port 2 is a bidirectional port with internal pull-up resistors. Port 2 pins that have 1s written to them are pulled high by the internal pull-up resistors, and in that state can be used as inputs. As inputs, Port 2 pins being pulled externally low sources current because of the internal pull-up resistors. External Memory Addresses (A8/A16). Port 2 emits the high order address bytes during fetches from external program memory and middle and high order address bytes during accesses to the external 24-bit external data memory space.
P2.1/A9/A17	29	31	I/O I/O	Input/Output Port 2 (P2.1). Port 2 is a bidirectional port with internal pull-up resistors. Port 2 pins that have 1s written to them are pulled high by the internal pull-up resistors, and in that state can be used as inputs. As inputs, Port 2 pins being pulled externally low sources current because of the internal pull-up resistors. External Memory Addresses (A9/A17). Port 2 emits the high order address bytes during fetches from external program memory and middle and high order address bytes during accesses to the external 24-bit external data memory space.
P2.2/A10/A18	30	32	I/O I/O	Input/Output Port 2 (P2.2). Port 2 is a bidirectional port with internal pull-up resistors. Port 2 pins that have 1s written to them are pulled high by the internal pull-up resistors, and in that state can be used as inputs. As inputs, Port 2 pins being pulled externally low sources current because of the internal pull-up resistors. External Memory Addresses (A10/A18). Port 2 emits the high order address bytes during fetches from external program memory and middle and high order address bytes during accesses to the external 24-bit external data memory space.
P2.3/A11/A19	31	33	I/O I/O	Input/Output Port 2 (P2.3). Port 2 is a bidirectional port with internal pull-up resistors. Port 2 pins that have 1s written to them are pulled high by the internal pull-up resistors, and in that state can be used as inputs. As inputs, Port 2 pins being pulled externally low sources current because of the internal pull-up resistors. External Memory Addresses (A11/A19). Port 2 emits the high order address bytes during fetches from external program memory and middle and high order address bytes during accesses to the external 24-bit external data memory space.
XTAL1	32	34	I	Input to the Inverting Oscillator Amplifier.

Mnemonic	Pin No.		Type	Description
	MQFP	LFCSP		
XTAL2	33	35	O	Output of the Inverting Oscillator Amplifier.
P2.4/A12/A20	36	39	I/O	Input/Output Port 2 (P2.4). Port 2 is a bidirectional port with internal pull-up resistors. Port 2 pins that have 1s written to them are pulled high by the internal pull-up resistors, and in that state can be used as inputs. As inputs, Port 2 pins being pulled externally low sources current because of the internal pull-up resistors.
			I/O	External Memory Addresses (A12/A20). Port 2 emits the high order address bytes during fetches from external program memory and middle and high order address bytes during accesses to the external 24-bit external data memory space.
P2.5/A13/A21	37	40	I/O	Input/Output Port 2 (P2.5). Port 2 is a bidirectional port with internal pull-up resistors. Port 2 pins that have 1s written to them are pulled high by the internal pull-up resistors, and in that state can be used as inputs. As inputs, Port 2 pins being pulled externally low sources current because of the internal pull-up resistors.
			I/O	External Memory Addresses (A13/A21). Port 2 emits the high order address bytes during fetches from external program memory and middle and high order address bytes during accesses to the external 24-bit external data memory space.
P2.6/PWM0/A14/A22	38	41	I/O	Input/Output Port 2 (P2.6). Port 2 is a bidirectional port with internal pull-up resistors. Port 2 pins that have 1s written to them are pulled high by the internal pull-up resistors, and in that state can be used as inputs. As inputs, Port 2 pins being pulled externally low sources current because of the internal pull-up resistors.
			O	PWM0 Voltage Output (PWM0). PWM outputs can be configured to use Port 2.6 and Port 2.7 or Port 3.4 and Port 3.3
			I/O	External Memory Addresses (A14/A22). Port 2 emits the high order address bytes during fetches from external program memory and middle and high order address bytes during accesses to the external 24-bit external data memory space.
P2.7/PWM1/A15/A23	39	42	I/O	Input/Output Port 2 (P2.7). Port 2 is a bidirectional port with internal pull-up resistors. Port 2 pins that have 1s written to them are pulled high by the internal pull-up resistors, and in that state can be used as inputs. As inputs, Port 2 pins being pulled externally low sources current because of the internal pull-up resistors.
			O	PWM1 Voltage Output (PWM1). See the ADuC832 Configuration SFR (CFG832) section for further information.
			I/O	External Memory Addresses (A15/A23). Port 2 emits the high order address bytes during fetches from external program memory and middle and high order address bytes during accesses to the external 24-bit external data memory space.
$\overline{\text{EA}}$	40	43	I	External Access Enable, Logic Input. When held high, this input enables the device to fetch code from internal program memory locations 0000H to 1FFFH. When held low, this input enables the device to fetch all instructions from external program memory. This pin should not be left floating.
$\overline{\text{PSEN}}$	41	44	O	Program Store Enable, Logic Output. This output is a control signal that enables the external program memory to the bus during external fetch operations. It is active every six oscillator periods except during external <u>data</u> memory accesses. This pin remains high during internal program execution. PSEN can also be used to enable serial download mode when pulled low through a resistor on power-up or reset.
ALE	42	45	O	Address Latch Enable, Logic Output. This output is used to latch the low byte (and page byte for 24-bit address space accesses) of the address into external memory during normal operation. It is activated every six oscillator periods except during an external data memory access.
P0.0/AD0	43	46	I/O	Input/Output Port 0 (P0.0). Port 0 is an 8-Bit Open-Drain Bidirectional I/O Port. Port 0 pins that have 1s written to them float and in that state can be used as high impedance inputs.
			I/O	External Memory Address and Data (AD0). Port 0 is also the multiplexed low order address and data bus during accesses to external program or data memory. In this application, it uses strong internal pull-ups when emitting 1s.
P0.1/AD1	44	47	I/O	Input/Output Port 0 (P0.1). Port 0 is an 8-Bit Open-Drain Bidirectional I/O Port. Port 0 pins that have 1s written to them float and in that state can be used as high impedance inputs.
			I/O	External Memory Address and Data (AD1). Port 0 is also the multiplexed low order address and data bus during accesses to external program or data memory. In this application, it uses strong internal pull-ups when emitting 1s.

Mnemonic	Pin No.		Type	Description
	MQFP	LFCSP		
P0.2/AD2	45	48	I/O	Input/Output Port 0 (P0.2). Port 0 is an 8-Bit Open-Drain Bidirectional I/O Port. Port 0 pins that have 1s written to them float and in that state can be used as high impedance inputs. External Memory Address and Data (AD2). Port 0 is also the multiplexed low order address and data bus during accesses to external program or data memory. In this application, it uses strong internal pull-ups when emitting 1s.
P0.3/AD3	46	49	I/O	Input/Output Port 0 (P0.3). Port 0 is an 8-Bit Open-Drain Bidirectional I/O Port. Port 0 pins that have 1s written to them float and in that state can be used as high impedance inputs.
			I/O	External Memory Address and Data (AD3). Port 0 is also the multiplexed low order address and data bus during accesses to external program or data memory. In this application, it uses strong internal pull-ups when emitting 1s.
P0.4/AD4	49	52	I/O	Input/Output Port 0 (P0.4). Port 0 is an 8-Bit Open-Drain Bidirectional I/O Port. Port 0 pins that have 1s written to them float and in that state can be used as high impedance inputs.
			I/O	External Memory Address and Data (AD4). Port 0 is also the multiplexed low order address and data bus during accesses to external program or data memory. In this application, it uses strong internal pull-ups when emitting 1s.
P0.5/AD5	50	53	I/O	Input/Output Port 0 (P0.5). Port 0 is an 8-Bit Open-Drain Bidirectional I/O Port. Port 0 pins that have 1s written to them float and in that state can be used as high impedance inputs.
			I/O	External Memory Address and Data (AD5). Port 0 is also the multiplexed low order address and data bus during accesses to external program or data memory. In this application, it uses strong internal pull-ups when emitting 1s.
P0.6/AD6	51	54	I/O	Input/Output Port 0 (P0.6). Port 0 is an 8-Bit Open-Drain Bidirectional I/O Port. Port 0 pins that have 1s written to them float and in that state can be used as high impedance inputs.
			I/O	External Memory Address and Data (AD6). Port 0 is also the multiplexed low order address and data bus during accesses to external program or data memory. In this application, it uses strong internal pull-ups when emitting 1s.
P0.7/AD7	52	56	I/O	Input/Output Port 0 (P0.7). Port 0 is an 8-Bit Open-Drain Bidirectional I/O Port. Port 0 pins that have 1s written to them float and in that state can be used as high impedance inputs. External Memory Address and Data (AD7). Port 0 is also the multiplexed low order address and data bus during accesses to external program or data memory. In this application, it uses strong internal pull-ups when emitting 1s.

¹ N/A means not applicable.

TYPICAL PERFORMANCE CHARACTERISTICS

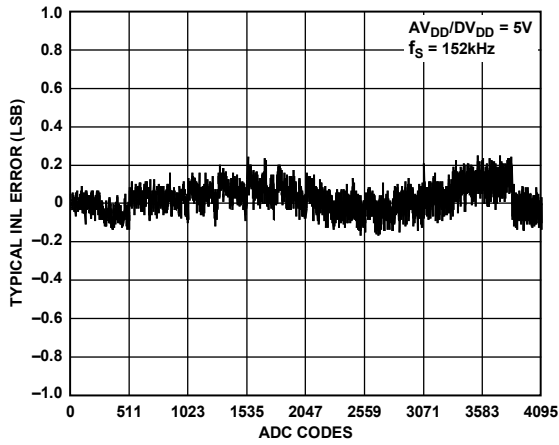

Figure 16. Typical INL Error, $V_{DD} = 5V$

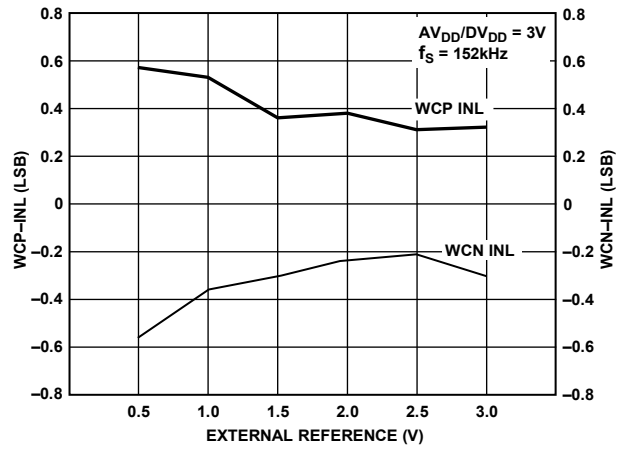

Figure 19. Typical Worst-Case INL Error vs. V_{REF} , $V_{DD} = 3V$

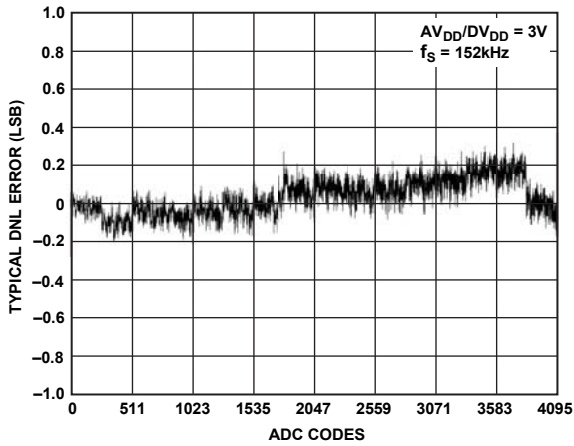

Figure 17. Typical DNL Error, $V_{DD} = 3V$

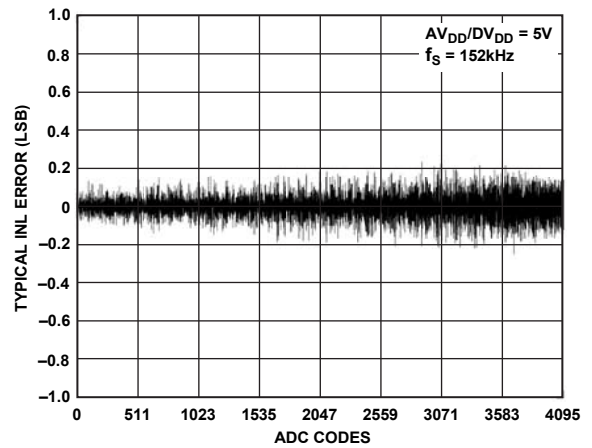

Figure 20. Typical DNL Error, $V_{DD} = 5V$

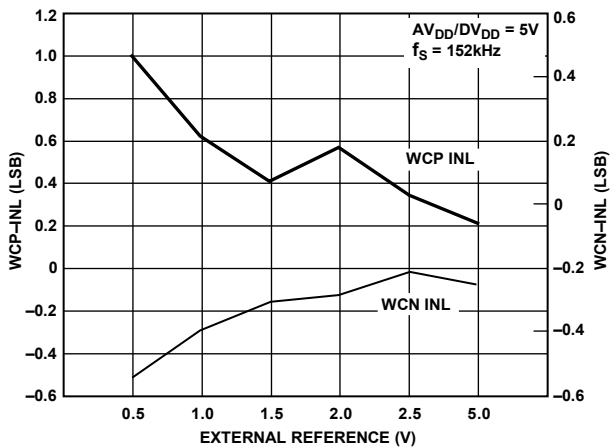

Figure 18. Typical Worst-Case INL Error vs. V_{REF} , $V_{DD} = 5V$

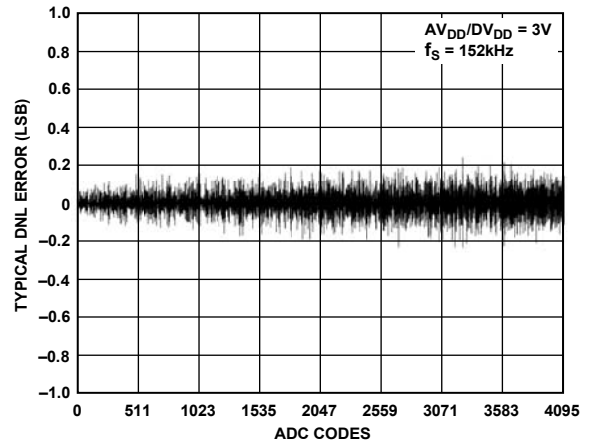

Figure 21. Typical DNL Error, $V_{DD} = 3V$



Figure 22. Typical Worst-Case DNL Error vs. V_{REF} , $V_{DD} = 5 V$

02987-011

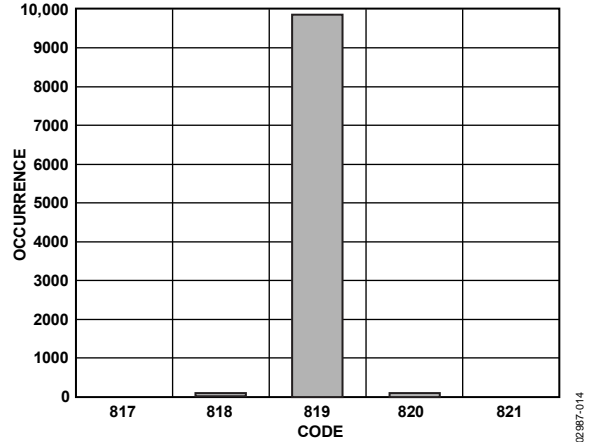

Figure 25. Code Histogram Plot, $V_{DD} = 3 V$

02987-014



Figure 23. Typical Worst-Case DNL Error vs. V_{REF} , $V_{DD} = 3 V$

02987-012

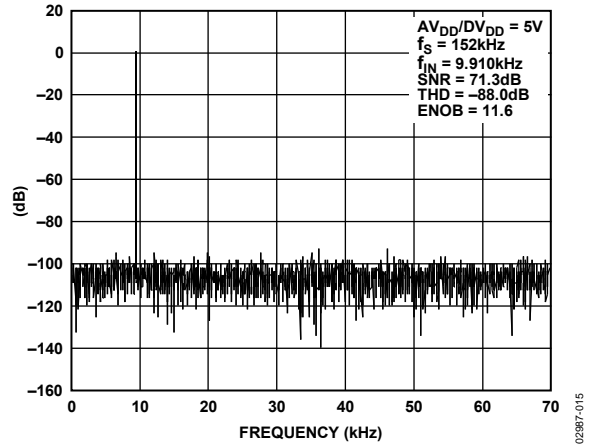

Figure 26. Dynamic Performance at $V_{DD} = 5 V$

02987-015



Figure 24. Code Histogram Plot, $V_{DD} = 5 V$

02987-013

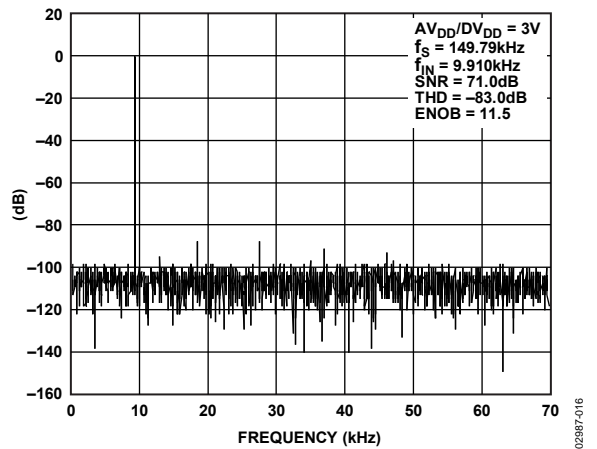

Figure 27. Dynamic Performance at $V_{DD} = 3 V$

02987-016



Figure 28. Typical Dynamic Performance vs. V_{REF} , $V_{DD} = 5 V$

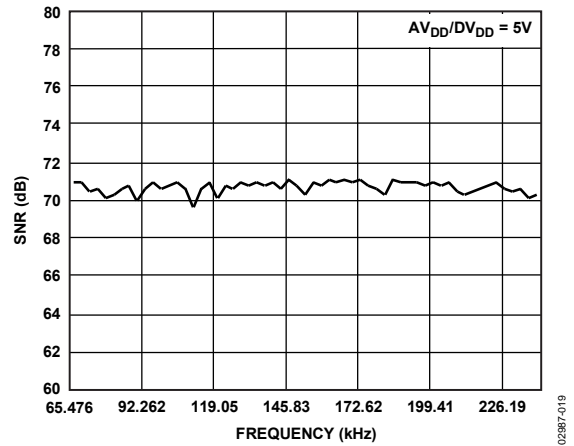

Figure 30. Typical Dynamic Performance vs. Sampling Frequency



Figure 29. Typical Dynamic Performance vs. V_{REF} , $V_{DD} = 3 V$

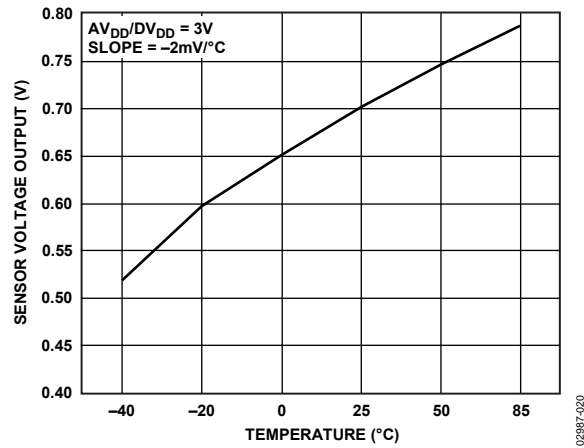

Figure 31. Typical Temperature Sensor Output vs. Temperature

TERMINOLOGY

ADC SPECIFICATIONS

Integral Nonlinearity

This is the maximum deviation of any code from a straight line passing through the endpoints of the ADC transfer function. The endpoints of the transfer function are zero scale, a point $\frac{1}{2}$ LSB below the first code transition, and full scale, a point $\frac{1}{2}$ LSB above the last code transition.

Differential Nonlinearity

This is the difference between the measured and the ideal 1 LSB change between any two adjacent codes in the ADC.

Offset Error

This is the deviation of the first code transition (0000 ... 000) to (0000 ... 001) from the ideal, that is, $+\frac{1}{2}$ LSB.

Gain Error

This is the deviation of the last code transition from the ideal analog input voltage (full scale – 1.5 LSB) after the offset error has been adjusted out.

Signal-to-Noise and Distortion (SINAD) Ratio

This is the measured ratio of signal-to-noise and distortion at the output of the ADC. The signal is the rms amplitude of the fundamental. Noise is the rms sum of all nonfundamental signals up to half the sampling frequency ($f_s/2$), excluding dc. The ratio is dependent upon the number of quantization levels in the digitization process; the more levels there are, the smaller the quantization noise. The theoretical signal to (noise + distortion) ratio for an ideal N-bit converter with a sine wave input is given by:

$$\text{Signal-to-Noise and Distortion} = (6.02N + 1.76) \text{ dB}$$

Thus for a 12-bit converter, this is 74 dB.

Total Harmonic Distortion

Total harmonic distortion is the ratio of the rms sum of the harmonics to the fundamental.

DAC SPECIFICATIONS

Relative Accuracy

Relative accuracy or endpoint linearity is a measure of the maximum deviation from a straight line passing through the endpoints of the DAC transfer function. It is measured after adjusting for zero error and full-scale error.

Voltage Output Settling Time

This is the amount of time it takes for the output to settle to a specified level for a full-scale input change.

Digital-to-Analog Glitch Energy

This is the amount of charge injected into the analog output when the inputs change state. It is specified as the area of the glitch in nV sec.

EXPLANATION OF TYPICAL PERFORMANCE PLOTS

The plots presented in the Typical Performance Characteristics section illustrate typical performance of the [ADuC832](#) under various operating conditions.

Figure 16 and Figure 17 show typical ADC integral nonlinearity (INL) errors from ADC Code 0 to Code 4095 at 5 V and 3 V supplies, respectively. The ADC is using its internal reference (2.5 V) and operating at a sampling rate of 152 kHz, and the typically worst-case errors in both plots are slightly less than 0.3 LSBs.

Figure 18 and Figure 19 show the variation in worst-case positive (WCP) INL and worst-case negative (WCN) INL vs. external reference input voltage.

Figure 20 and Figure 21 show typical ADC differential nonlinearity (DNL) errors from ADC Code 0 to Code 4095 at 5 V and 3 V supplies, respectively. The ADC is using its internal reference (2.5 V) and operating at a sampling rate of 152 kHz, and the typically worst-case errors in both plots is slightly less than 0.2 LSBs.

Figure 22 and Figure 23 show the variation in worst-case positive (WCP) DNL and worst-case negative (WCN) DNL vs. external reference input voltage.

Figure 24 shows a histogram plot of 10,000 ADC conversion results on a dc input with $V_{DD} = 5$ V. The plot illustrates an

excellent code distribution pointing to the low noise performance of the on-chip precision ADC.

Figure 25 shows a histogram plot of 10,000 ADC conversion results on a dc input for $V_{DD} = 3$ V. The plot again illustrates a very tight code distribution of 1 LSB with the majority of codes appearing in one output pin.

Figure 26 and Figure 27 show typical FFT plots for the [ADuC832](#). These plots were generated using an external clock input. The ADC is using its internal reference (2.5 V) sampling a full-scale, 10 kHz sine wave test tone input at a sampling rate of 149.79 kHz. The resultant FFTs shown at 5 V and 3 V supplies illustrate an excellent 100 dB noise floor, 71 dB or greater signal-to-noise ratio (SNR), and THD greater than -80 dB.

Figure 28 and Figure 29 show typical dynamic performance vs. external reference voltages. Again, excellent ac performance can be observed in both plots with some roll-off being observed as V_{REF} falls below 1 V.

Figure 30 shows typical dynamic performance vs. sampling frequency. SNR levels of 71 dB are obtained across the sampling range of the [ADuC832](#).

Figure 31 shows the voltage output of the on-chip temperature sensor vs. temperature. Although the initial voltage output at 25°C can vary from part to part, the resulting slope of -2 mV/°C is constant across all parts.

MEMORY ORGANIZATION

The ADuC832 contains four different memory blocks:

- 62 kB of on-chip Flash/EE program memory
- 4 kB of on-chip Flash/EE data memory
- 256 bytes of general-purpose RAM
- 2 kB of internal XRAM

FLASH/EE PROGRAM MEMORY

The ADuC832 provides 62 kB of Flash/EE program memory to run user code. The user can choose to run code from this internal memory or from an external program memory.

If the user applies power or resets the device while the \overline{EA} pin is pulled low, the part executes code from the external program space; otherwise, the part defaults to code execution from its internal 62 kB of Flash/EE program memory. Unlike the ADuC812, where code execution can overflow from the internal code space to external code space once the PC becomes greater than 1FFFH, the ADuC832 does not support the rollover from F7FFH in internal code space to F800H in external code space. Instead, the 2048 bytes between F800H and FFFFH appear as NOP instructions to user code.

This internal code space can be downloaded via the UART serial port while the device is in-circuit. During runtime, 56 kB of the program memory can be reprogrammed; thus the code space can be upgraded in the field using a user defined protocol, or it can be used as a data memory (for more details, see the Using the Flash/EE Program Memory section).

FLASH/EE DATA MEMORY

4 kB of Flash/EE data memory are available to the user and can be accessed indirectly via a group of control registers mapped into the Special Function Register (SFR) area. Access to the Flash/EE data memory is discussed in detail in the Using the Flash/EE Data Memory section.

GENERAL-PURPOSE RAM

The general-purpose RAM is divided into two separate memories, the upper and the lower 128 bytes of RAM. The lower 128 bytes of RAM can be accessed through direct or indirect addressing. The upper 128 bytes of RAM can only be accessed through indirect addressing because it shares the same address space as the SFR space, which can only be accessed through direct addressing.

The lower 128 bytes of internal data memory are mapped as shown in Figure 32. The lowest 32 bytes are grouped into four banks of eight registers addressed as R0 through R7. The next 16 bytes (128 bits), above the register banks, form a block of bit addressable memory space at Address 20H through Address 2FH. The stack can be located anywhere in the internal memory address space, and the stack depth can be expanded up to 2048 bytes.

A reset initializes the stack pointer to Location 07H and increments it once before loading the stack to start from Location 08H, which is also the first register (R0) of Register Bank 1. Thus, if using more than one register bank, the stack pointer should be initialized to an area of RAM not used for data storage.



Figure 32. Lower 128 Bytes of Internal Data Memory

The ADuC832 contains 2048 bytes of internal XRAM, 1792 bytes of which can be configured to be used as an extended 11-bit stack pointer.

By default, the stack operates exactly like an 8052 in that it rolls over from FFH to 00H in the general-purpose RAM. On the ADuC832, however, it is possible (by setting CFG832[7]) to enable the 11-bit extended stack pointer. In this case, the stack rolls over from 00FFH in RAM to 0100H in XRAM.

The 11-bit stack pointer is visible in the SP and SPH SFRs. The SP SFR is located at 81H as with a standard 8052. The SPH SFR is located at B7H. The three LSBs of this SFR contain the three extra bits necessary to extend the 8-bit stack pointer into an 11-bit stack pointer.

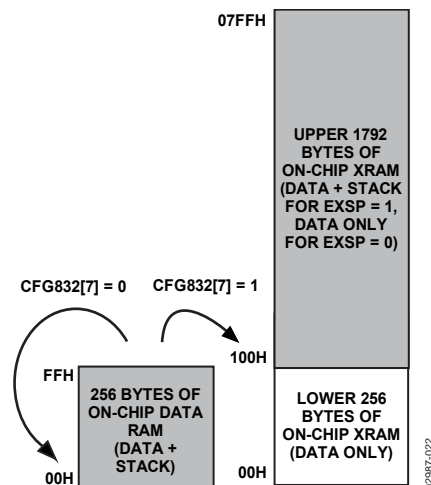

Figure 33. Extended Stack Pointer Operation

EXTERNAL DATA MEMORY (EXTERNAL XRAM)

Similar to a standard 8051-compatible core, the [ADuC832](#) can access external data memory using a MOVX instruction. The MOVX instruction automatically outputs the various control strobes required to access the data memory.

The [ADuC832](#), however, can access up to 16 MB of external data memory. This is an enhancement of the 64 kB external data memory space available on a standard 8051-compatible core.

The external data memory is discussed in more detail in the [ADuC832 Hardware Design Considerations](#) section.

INTERNAL XRAM

There are 2 kB of on-chip data memory on the [ADuC832](#). This memory, although on chip, is also accessed via the MOVX instruction. The 2 kB of internal XRAM are mapped into the bottom 2 kB of the external address space if CFG832[0] is set. Otherwise, access to the external data memory occurs similar to a standard 8051. When using the internal XRAM, Port 0 and Port 2 are free to be used as general-purpose I/Os.



Figure 34. Internal and External XRAM

SPECIAL FUNCTION REGISTERS (SFRS)

The SFR space is mapped into the upper 128 bytes of internal data memory space and accessed by direct addressing only. It provides an interface between the CPU and all on-chip peripherals. A block diagram showing the programming model of the ADuC832 via the SFR area is shown in Figure 35.

All registers, except the program counter (PC) and the four general-purpose register banks, reside in the SFR area. The SFR registers include control, configuration, and data registers that provide an interface between the CPU and all on-chip peripherals.



Figure 35. Programming Model

ACCUMULATOR SFR (ACC)

ACC is the accumulator register and is used for math operations including addition, subtraction, integer multiplication and division, and Boolean bit manipulations. The mnemonics for accumulator-specific instructions refer to the accumulator as A.

B SFR (B)

The B register is used with the ACC for multiplication and division operations. For other instructions, it can be treated as a general-purpose scratch pad register.

STACK POINTER (SP AND SPH)

The SP SFR is the stack pointer and is used to hold an internal RAM address that is called the top of the stack. The SP register is incremented before data is stored during push and call executions. While the stack may reside anywhere in on-chip RAM, the SP register is initialized to 07H after a reset. This causes the stack to begin at Location 08H.

As mentioned previously, the ADuC832 offers an extended 11-bit stack pointer. The three extra bits to make up the 11-bit stack pointer are the three LSBs of the SPH byte located at B7H.

DATA POINTER (DPTR)

The data pointer is made up of three 8-bit registers, named DPP (page byte), DPH (high byte), and DPL (low byte). These are

used to provide memory addresses for internal and external code access and external data access. It can be manipulated as a 16-bit register (DPTR = DPH, DPL), although INC DPTR instructions automatically carry over to DPP, or as three independent 8-bit registers (DPP, DPH, and DPL).

The ADuC832 supports dual data pointers. Refer to the Dual Data Pointers section.

PROGRAM STATUS WORD (PSW)

SFR Address: D0H

Power-On Default Value: 00H

Bit Addressable: Yes

The PSW SFR contains several bits reflecting the current status of the CPU, as detailed in Table 14.

Table 14. PSW SFR Bit Designations

Bit	Name	Description	
[7]	CY	Carry flag	
[6]	AC	Auxiliary carry flag	
[5]	F0	General-purpose flag	
[4:3]	RS[1:0]	Register bank select bits	
	RS1	RS0	Selected Bank
	0	0	0
	0	1	1
	1	0	2
	1	1	3
[2]	OV	Overflow flag	
[1]	F1	General-purpose flag	
[0]	P	Parity bit	

POWER CONTROL SFR (PCON)

SFR Address: 87H

Power-On Default Value: 00H

Bit Addressable: No

The PCON SFR contains bits for power-saving options and general-purpose status flags, as shown in Table 15.

Table 15. PCON SFR Bit Designations

Bit	Name	Description
[7]	SMOD	Double UART baud rate
[6]	SERIPD	I ² C/SPI power-down interrupt enable
[5]	INTOPD	INT0 power-down interrupt enable
[4]	ALEOFF	Disable ALE output
[3]	GF1	General-purpose flag bit
[2]	GF0	General-purpose flag bit
[1]	PD	Power-down mode enable
[0]	IDL	Idle mode enable

SPECIAL FUNCTION REGISTERS

All registers except the program counter and the four general-purpose register banks reside in the special function register (SFR) area. The SFR registers include control, configuration, and data registers that provide an interface between the CPU and other on-chip peripherals.

Figure 36 shows a full SFR memory map and SFR contents on reset. Unoccupied SFR locations are shown dark-shaded in Figure 36 (labeled reserved). Unoccupied locations in the SFR address space are not implemented, that is, no register exists at

that location. If an unoccupied location is read, an unspecified value is returned. SFR locations reserved for on-chip testing are shown lighter shaded in Figure 36 (labeled reserved) and should not be accessed by user software. Sixteen of the SFR locations are also bit addressable and denoted by Footnote 1 in Figure 36, that is, the bit addressable SFRs are those whose address ends in 0H or 8H.

ISPI FFH 0	WCOL FEH 0	SPE FDH 0	SPIM FCH 0	CPOL FBH 0	CPHA FAH 1	SPR1 F9H 0	SPR0 F8H 0	BITS	SPICON ¹ F8H 04H	DAC0L F9H 00H	DAC0H FAH 00H	DAC1L FBH 00H	DAC1H FCH 00H	DACCON FDH 04H	RESERVED	RESERVED
F7H 0	F6H 0	F5H 0	F4H 0	F3H 0	F2H 0	F1H 0	F0H 0	BITS	B ¹ F0H 00H	ADCOFSL ³ F1H 00H	ADCOFSH ³ F2H 20H	ADCGAINL ³ F3H 00H	ADCGAINH ³ F4H 00H	ADCCON3 F5H 00H	RESERVED	SPIDAT F7H 00H
MDO EFH 0	MDE EEH 0	MCO EDH 0	MDI ECH 0	I2CM EBH 0	I2CRS EAH 0	I2CTX E9H 0	I2CI E8H 0	BITS	I2CCON ¹ E8H 00H	RESERVED	RESERVED	RESERVED	RESERVED	RESERVED	RESERVED	ADCCON1 EFH 00H
E7H 0	E6H 0	E5H 0	E4H 0	E3H 0	E2H 0	E1H 0	E0H 0	BITS	ACC ¹ E0H 00H	RESERVED	RESERVED	RESERVED	RESERVED	RESERVED	RESERVED	RESERVED
ADC1 DFH 0	DMA DEH 0	CCONV DDH 0	SCONV DCH 0	CS3 DBH 0	CS2 DAH 0	CS1 D9H 0	CS0 D8H 0	BITS	ADCCON2 ¹ D8H 00H	ADCDATAL D9H 00H	ADCDATAH DAH 00H	RESERVED	RESERVED	RESERVED	RESERVED	PSMCON DFH DEH
CY D7H 0	AC D6H 0	F0 D5H 0	RS1 D4H 0	RS0 D3H 0	OV D2H 0	F1 D1H 0	P D0H 0	BITS	PSW ¹ D0H 00H	RESERVED	DMAL D2H 00H	DMAH D3H 00H	DMAP D4H 00H	RESERVED	RESERVED	PLLCON D7H 53H
TF2 CFH 0	EXF2 CEH 0	RCLK CDH 0	TCLK CCH 0	EXEN2 CBH 0	TR2 CAH 0	CNT2 C9H 0	CAP2 C8H 0	BITS	T2CON ¹ C8H 00H	RESERVED	RCAP2L CAH 00H	RCAP2H CBH 00H	TL2 CCH 00H	TH2 CDH 00H	RESERVED	RESERVED
PRE3 C7H 0	PRE2 C6H 0	PRE1 C5H 0	PRE0 C4H 1	WDIR C3H 0	WDS C2H 0	WDE C1H 0	WDWR C0H 0	BITS	WDCON ¹ C0H 10H	RESERVED	CHIPID C2H 2XH	RESERVED	RESERVED	RESERVED	EADR1 C6H 00H	EADRH C7H 00H
BFH 0	PADC BEH 0	PT2 BDH 0	PS BCH 0	PT1 BBH 0	PX1 BAH 0	PT0 B9H 0	PX0 B8H 0	BITS	IP ¹ B8H 00H	ECON B9H 00H	RESERVED	RESERVED	EDATA1 BCH 00H	EDATA2 BDH 00H	EDATA3 BEH 00H	EDATA4 BFH 00H
RD B7H 1	WR B6H 1	T1 B5H 1	T0 B4H 1	INT1 B3H 1	INT0 B2H 1	TxD B1H 1	RxD B0H 1	BITS	P3 ¹ B0H FFH	PWM0L B1H 00H	PWM0H B2H 00H	PWM1L B3H 00H	PWM1H B4H 00H	NOT USED	NOT USED	SPH B7H 00H
EA AFH 0	EADC AEH 0	ET2 ADH 0	ES ACH 0	ET1 ABH 0	EX1 AAH 0	ET0 A9H 0	EX0 A8H 0	BITS	IE ¹ A8H 00H	IEIP2 A9H A0H	RESERVED	RESERVED	RESERVED	RESERVED	PWMCON AEH 00H	CFG832 AFH 00H
A7H 1	A6H 1	A5H 1	A4H 1	A3H 1	A2H 1	A1H 1	A0H 1	BITS	P2 ¹ A0H FFH	TIMECON A1H 00H	HTHSEC A2H 00H	SEC A3H 00H	MIN A4H 00H	HOUR A5H 00H	INTVAL A6H 00H	DPCON A7H 00H
SM0 9FH 0	SM1 9EH 0	SM2 9DH 0	REN 9CH 0	TB8 9BH 0	RB8 9AH 0	TI 99H 0	RI 98H 0	BITS	SCON ¹ 98H 00H	SBUF 99H 00H	I2CDAT 9AH 00H	I2CADD 9BH 55H	NOT USED	T3FD 9DH 00H	T3CON 9EH 00H	NOT USED
97H 1	96H 1	95H 1	94H 1	93H 1	92H 1	T2EX 91H 1	T2 90H 1	BITS	P1 ^{1, 2} 90H FFH	NOT USED	NOT USED	NOT USED	NOT USED	NOT USED	NOT USED	NOT USED
TF1 8FH 0	TR1 8EH 0	TF0 8DH 0	TR0 8CH 0	IE1 8BH 0	IT1 8AH 0	IE0 89H 0	IT0 88H 0	BITS	TCON ¹ 88H 00H	TMOD 89H 00H	TL0 8AH 00H	TL1 8BH 00H	TH0 8CH 00H	TH1 8DH 00H	RESERVED	RESERVED
87H 1	86H 1	85H 1	84H 1	83H 1	82H 1	81H 1	80H 1	BITS	P0 ¹ 80H FFH	SP 81H 07H	DPL 82H 00H	DPH 83H 00H	DPP 84H 00H	RESERVED	RESERVED	PCON 87H 00H

SFR MAP KEY:

THESE BITS ARE CONTAINED IN THIS BYTE.



¹SFRs WHOSE ADDRESS ENDS IN 0H OR 8H ARE BIT ADDRESSABLE.
²THE PRIMARY FUNCTION OF PORT1 IS AS AN ANALOG INPUT PORT; THEREFORE, TO ENABLE THE DIGITAL SECONDARY FUNCTIONS ON THESE PORT PINS, WRITE A 0 TO THE CORRESPONDING PORT 1 SFR BIT.
³CALIBRATION COEFFICIENTS ARE PRECONFIGURED ON POWER-UP TO FACTORY CALIBRATED VALUES.

Figure 36. Special Function Register Locations and Reset Values

ADC CIRCUIT INFORMATION

GENERAL OVERVIEW

The ADC conversion block incorporates a fast, 8-channel, 12-bit, single-supply ADC. This block provides the user with multichannel mux, track/hold, on-chip reference, calibration features, and an ADC. All components in this block are easily configured via a three-register SFR interface.

The ADC consists of a conventional successive approximation converter based around a capacitor DAC. The converter accepts an analog input range of 0 V to V_{REF} . A high precision, low drift, and factory calibrated 2.5 V reference is provided on-chip. An external reference can be connected as described in the Voltage Reference Connections section. This external reference can be in the range of 1 V to AV_{DD} .

Single step or continuous conversion modes can be initiated in software or alternatively by applying a convert signal to an external pin. Timer 2 can also be configured to generate a repetitive trigger for ADC conversions. The ADC can be configured to operate in a DMA mode whereby the ADC block continuously converts and captures samples to an external RAM space without any interaction from the MCU core. This automatic capture facility can extend through a 16 MB external data memory space.

The ADuC832 is shipped with factory programmed calibration coefficients that are automatically downloaded to the ADC on power-up, ensuring optimum ADC performance. The ADC core contains internal offset and gain calibration registers that can be hardware calibrated to minimize system errors.

A voltage output from an on-chip band gap reference proportional to absolute temperature can also be routed through the front-end ADC multiplexer (effectively a ninth ADC channel input) facilitating a temperature sensor implementation.

ADC TRANSFER FUNCTION

The analog input range for the ADC is 0 V to V_{REF} . For this range, the designed code transitions occur midway between successive integer LSB values (that is, 1/2 LSB, 3/2 LSBs, 5/2 LSBs...FS - 3/2 LSBs). The output coding is straight binary with 1 LSB = $FS/4096$ or $2.5\text{ V}/4096 = 0.61\text{ mV}$ when $V_{REF} = 2.5\text{ V}$. The ideal input/output transfer characteristic for the 0 V to V_{REF} range is shown in Figure 37.

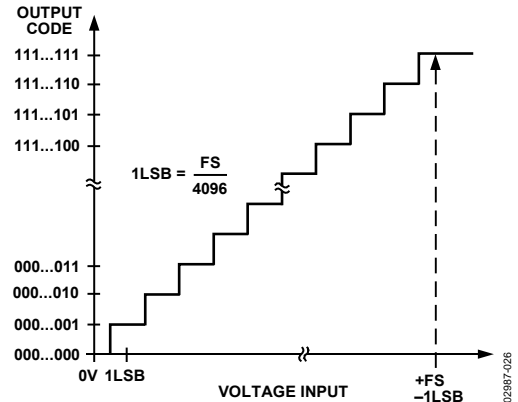

Figure 37. ADC Transfer Function

TYPICAL OPERATION

Once configured via the ADCCON1 to ADCCON3 SFRs, the ADC converts the analog input and provides an ADC 12-bit result word in the ADCDATAH/ADCDATAHL SFRs. The top four bits of the ADCDATAH SFR are written with the channel selection bits to identify the channel result. The format of the ADC 12-bit result word is shown in Figure 38.

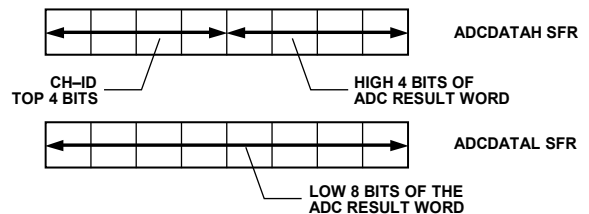

Figure 38. ADC Result Format

ADCCON1 (ADC Control SFR 1)

SFR Address: EFH
 SFR Power-On Default Value: 00H
 Bit Addressable: No

The ADCCON1 register controls conversion and acquisition times, hardware conversion modes, and power-down modes as detailed in Table 16.

Table 16. ADCCON1 SFR Bit Designations

Bit	Name	Description															
[7]	MD1	The mode bit selects the active operating mode of the ADC. Set by the user to power up the ADC. Cleared by the user to power down the ADC.															
[6]	EXT_REF	Set by the user to select an external reference. Cleared by the user to use the internal reference.															
[5]	CK1	The ADC clock divide bits (CK1, CK0) select the divide ratio for the PLL master clock used to generate the															
[4]	CK0	ADC clock. To ensure correct ADC operation, the divider ratio must be chosen to reduce the ADC clock to ≤ 4.5 MHz. A typical ADC conversion requires 17 ADC clocks. The divider ratio is selected as follows:															
		<table border="1"> <thead> <tr> <th>CK1</th> <th>CK0</th> <th>MCLK Divider</th> </tr> </thead> <tbody> <tr> <td>0</td> <td>0</td> <td>8</td> </tr> <tr> <td>0</td> <td>1</td> <td>4</td> </tr> <tr> <td>1</td> <td>0</td> <td>16</td> </tr> <tr> <td>1</td> <td>1</td> <td>32</td> </tr> </tbody> </table>	CK1	CK0	MCLK Divider	0	0	8	0	1	4	1	0	16	1	1	32
CK1	CK0	MCLK Divider															
0	0	8															
0	1	4															
1	0	16															
1	1	32															
[3:2]	AQ[1:0]	The ADC acquisition select bits (AQ1, AQ0) select the time provided for the input track-and-hold amplifier to acquire the input signal. An acquisition of three or more ADC clocks is recommended; clocks are selected as follows:															
		<table border="1"> <thead> <tr> <th>AQ1</th> <th>AQ0</th> <th>Number of ADC Clocks</th> </tr> </thead> <tbody> <tr> <td>0</td> <td>0</td> <td>1</td> </tr> <tr> <td>0</td> <td>1</td> <td>2</td> </tr> <tr> <td>1</td> <td>0</td> <td>3</td> </tr> <tr> <td>1</td> <td>1</td> <td>4</td> </tr> </tbody> </table>	AQ1	AQ0	Number of ADC Clocks	0	0	1	0	1	2	1	0	3	1	1	4
AQ1	AQ0	Number of ADC Clocks															
0	0	1															
0	1	2															
1	0	3															
1	1	4															
[1]	T2C	The Timer 2 conversion bit (T2C) is set by the user to enable the Timer 2 overflow bit to be used as the ADC convert start trigger input.															
[0]	EXC	The external trigger enable bit (EXC) is set by the user to allow the external Pin P3.5/T1/CONVST to be used as the active low convert start input. This input should be an active low pulse (minimum pulse width >100 ns) at the required sample rate.															

ADCCON2 (ADC Control SFR 2)

SFR Address: D8H

SFR Power-On Default Value: 00H

Bit Addressable: Yes

The ADCCON2 register controls ADC channel selection and conversion modes as detailed in Table 17.

Table 17. ADCCON2 SFR Bit Designations

Bit	Name	Description																																																																											
[7]	ADCI	The ADC interrupt bit (ADCI) is set by hardware at the end of a single ADC conversion cycle or at the end of a DMA block conversion. ADCI is cleared by hardware when the PC vectors to the ADC interrupt service routine. Otherwise, the ADCI bit should be cleared by user code.																																																																											
[6]	DMA	The DMA mode enable bit (DMA) is set by the user to enable a preconfigured ADC DMA mode of operation. A more detailed description of this mode is given in the ADC DMA Mode section. The DMA bit is automatically cleared to 0 at the end of a DMA cycle. Setting this bit causes the ALE output to cease, starting again when DMA is started, and operates correctly after DMA is complete.																																																																											
[5]	CCONV	The continuous conversion bit (CCONV) is set by the user to initiate the ADC into a continuous mode of conversion. In this mode, the ADC starts converting based on the timing and channel configuration already set up in the ADCCONx SFRs; the ADC automatically starts another conversion once a previous conversion has completed.																																																																											
[4]	SCONV	The single conversion bit (SCONV) is set to initiate a single conversion cycle. The SCONV bit is automatically reset to 0 on completion of the single conversion cycle.																																																																											
[3:0]	CS[3:0]	The channel selection bits (CS[3:0]) allow the user to program the ADC channel selection under software control. When a conversion is initiated, the channel converted is the one selected by these channel selection bits. In DMA mode, the channel selection is derived from the channel ID written to the external memory.																																																																											
		<table border="1"> <thead> <tr> <th>CS3</th> <th>CS2</th> <th>CS1</th> <th>CS0</th> <th>Channel Number</th> </tr> </thead> <tbody> <tr><td>0</td><td>0</td><td>0</td><td>0</td><td>0</td></tr> <tr><td>0</td><td>0</td><td>0</td><td>1</td><td>1</td></tr> <tr><td>0</td><td>0</td><td>1</td><td>0</td><td>2</td></tr> <tr><td>0</td><td>0</td><td>1</td><td>1</td><td>3</td></tr> <tr><td>0</td><td>1</td><td>0</td><td>0</td><td>4</td></tr> <tr><td>0</td><td>1</td><td>0</td><td>1</td><td>5</td></tr> <tr><td>0</td><td>1</td><td>1</td><td>0</td><td>6</td></tr> <tr><td>0</td><td>1</td><td>1</td><td>1</td><td>7</td></tr> <tr><td>1</td><td>0</td><td>0</td><td>0</td><td>Temperature sensor (requires minimum of 1 μs to acquire)</td></tr> <tr><td>1</td><td>0</td><td>0</td><td>1</td><td>DAC0 (only use with internal DAC output buffer on)</td></tr> <tr><td>1</td><td>0</td><td>1</td><td>0</td><td>DAC1 (only use with internal DAC output buffer on)</td></tr> <tr><td>1</td><td>0</td><td>1</td><td>1</td><td>AGND</td></tr> <tr><td>1</td><td>1</td><td>0</td><td>0</td><td>V_{REF}</td></tr> <tr><td>1</td><td>1</td><td>1</td><td>1</td><td>DMA stop (place in XRAM location to finish DMA sequence, see the ADC DMA Mode section)</td></tr> </tbody> </table>	CS3	CS2	CS1	CS0	Channel Number	0	0	0	0	0	0	0	0	1	1	0	0	1	0	2	0	0	1	1	3	0	1	0	0	4	0	1	0	1	5	0	1	1	0	6	0	1	1	1	7	1	0	0	0	Temperature sensor (requires minimum of 1 μ s to acquire)	1	0	0	1	DAC0 (only use with internal DAC output buffer on)	1	0	1	0	DAC1 (only use with internal DAC output buffer on)	1	0	1	1	AGND	1	1	0	0	V _{REF}	1	1	1	1	DMA stop (place in XRAM location to finish DMA sequence, see the ADC DMA Mode section)
CS3	CS2	CS1	CS0	Channel Number																																																																									
0	0	0	0	0																																																																									
0	0	0	1	1																																																																									
0	0	1	0	2																																																																									
0	0	1	1	3																																																																									
0	1	0	0	4																																																																									
0	1	0	1	5																																																																									
0	1	1	0	6																																																																									
0	1	1	1	7																																																																									
1	0	0	0	Temperature sensor (requires minimum of 1 μ s to acquire)																																																																									
1	0	0	1	DAC0 (only use with internal DAC output buffer on)																																																																									
1	0	1	0	DAC1 (only use with internal DAC output buffer on)																																																																									
1	0	1	1	AGND																																																																									
1	1	0	0	V _{REF}																																																																									
1	1	1	1	DMA stop (place in XRAM location to finish DMA sequence, see the ADC DMA Mode section)																																																																									
		All other combinations reserved																																																																											

ADCCON3 (ADC Control SFR 3)

SFR Address: F5H
 SFR Power-On Default Value: 00H
 Bit Addressable: No

The ADCCON3 register controls the operation of various calibration modes as well as giving an indication of ADC busy status.

Table 18. ADCCON3 SFR Bit Designations

Bit	Name	Description		
[7]	Busy	The ADC busy status bit is a read-only status bit that is set during a valid ADC conversion or calibration cycle. Busy is automatically cleared by the core at the end of conversion or calibration.		
[6]	GNCLD	Gain calibration disable bit. Set to 0 to enable gain calibration. Set to 1 to disable gain calibration.		
[5:4]	AVGS[1:0]	Number of averages selection bits. These bits select the number of ADC readings averaged during a calibration cycle.		
		AVGS1	AVGS0	Number of Averages
		0	0	15
		0	1	1
		1	0	31
	1	1	63	
[3]	RSVD	Reserved. This bit should always be written as 0.		
[2]	RSVD	This bit should always be written as 1 by the user when performing calibration.		
[1]	Typical	Calibration type select bit. This bit selects between offset (zero-scale) and gain (full-scale) calibration. Set to 0 for offset calibration. Set to 1 for gain calibration.		
[0]	SCAL	Start calibration cycle bit. When set, this bit starts the selected calibration cycle. It is automatically cleared when the calibration cycle is completed.		

DRIVING THE ANALOG-TO-DIGITAL CONVERTER

The ADC incorporates a successive approximation (SAR) architecture involving a charge-sampled input stage. Figure 39 shows the equivalent circuit of the analog input section. Each ADC conversion is divided into two distinct phases as defined by the position of the switches in Figure 39. During the sampling phase (with SW1 and SW2 in the track position), a charge proportional to the voltage on the analog input is developed across the input sampling capacitor. During the conversion phase (with both switches in the hold position) the capacitor DAC is adjusted via internal SAR logic until the voltage on Node A is 0, indicating that the sampled charge on the input capacitor is balanced out by the charge being output by the capacitor DAC. The digital value finally contained in the SAR is then latched out as the result of the ADC conversion. Control of the SAR, and timing of acquisition and sampling modes, is handled automatically by built-in ADC control logic. Acquisition and conversion times are also fully configurable under user control.

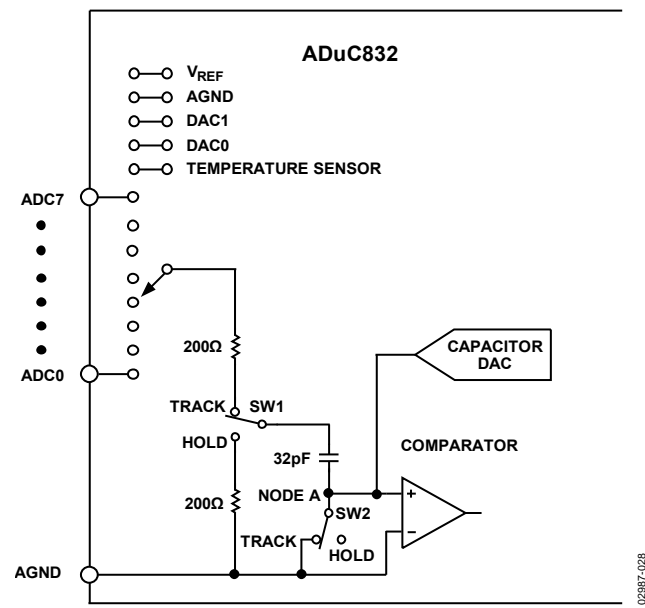

Figure 39. Internal ADC Structure

Note that whenever a new input channel is selected, a residual charge from the 32 pF sampling capacitor places a transient on the newly selected input. The signal source must be capable of recovering from this transient before the sampling switches are changed to hold mode. Delays can be inserted in software (between channel selection and conversion request) to account for input stage settling, but a hardware solution alleviates this burden from the software design task and ultimately results in a cleaner system implementation. One hardware solution would be to choose a very fast settling op amp to drive each analog input. Such an op amp would need to fully settle from a small signal transient in less than 300 ns to guarantee adequate settling under all software configurations. A better solution, recommended for use with any amplifier, is shown in Figure 40.

Though the circuit in Figure 40 may look like a simple antialiasing filter, it actually serves no such purpose because its corner frequency is well above the Nyquist frequency, even at a 200 kHz sample rate. Though the R/C does help to reject some incoming high frequency noise, its primary function is to ensure that the transient demands of the ADC input stage are met.



Figure 40. Buffering Analog Inputs

It does so by providing a capacitive bank from which the 32 pF sampling capacitor can draw its charge. Its voltage does not change by more than one count (1/4096) of the 12-bit transfer function when the 32 pF charge from a previous channel is dumped onto it. A larger capacitor can be used if desired, but not a larger resistor, for the following reasons.

The Schottky diodes in Figure 40 may be necessary to limit the voltage applied to the analog input pin as per the absolute maximum ratings (see Table 12). They are not necessary if the op amp is powered from the same supply as the ADuC832 because in that case the op amp is unable to generate voltages above V_{DD} or below ground. An op amp of some kind is necessary unless the signal source is very low impedance to begin with. DC leakage currents at the ADuC832 analog inputs can cause measurable dc errors with external source impedances as little as ~100 Ω. To ensure accurate ADC operation, keep the total source impedance at each analog input less than 61 Ω. Table 19 illustrates examples of how source impedance can affect dc accuracy.

Table 19. Source Impedance Examples

Source Impedance	Error from 1 μA Leakage Current	Error from 10 μA Leakage Current
61 Ω	61 μV = 0.1 LSB	610 μV = 1 LSB
610 Ω	610 μV = 1 LSB	6.1 mV = 10 LSB

Although Figure 40 shows the op amp operating at a gain of 1, it can be configured for any gain needed. Also, an instrumentation amplifier can be easily used in its place to condition differential signals. Use any modern amplifier that is capable of delivering the signal (0 V to V_{REF}) with minimal saturation. Some single-supply rail-to-rail op amps that are useful for this purpose include, but are not limited to, the ones given in Table 20. Visit www.analog.com for details on these and other op amps and instrumentation amps.

Table 20. Some Single-Supply Op Amps

Op Amp Model	Characteristics
OP281/OP481	Micropower
OP191/OP291/OP491	I/O Good up to V_{DD} , low cost
OP196/OP296/OP496	I/O to V_{DD} , micropower, low cost
ADA4610-1, OP249	High gain-bandwidth product (GBP)
OP162/OP262/OP462	High GBP, micro package
AD820/AD822/AD824	FET input, low cost
AD823	FET input, high GBP

Keep in mind that the ADC's transfer function is 0 V to V_{REF} , and any signal range lost to amplifier saturation near ground impacts dynamic range. Though the op amps in Table 20 are capable of delivering output signals very closely approaching ground, no amplifier can deliver signals all the way to ground when powered by a single supply. Therefore, if a negative supply is available, consider using it to power the front-end amplifiers. However, be sure to include the Schottky diodes shown in Figure 40 (or at least the lower of the two diodes) to protect the analog input from undervoltage conditions. In summary, use the circuit of Figure 40 to drive the analog input ADCx pins of the ADuC832.

VOLTAGE REFERENCE CONNECTIONS

The on-chip 2.5 V band gap voltage reference can be used as the reference source for the ADC and DACs. To ensure the accuracy of the voltage reference, the user must decouple the V_{REF} pin to ground with a 0.1 μ F capacitor, and the C_{REF} pin to ground with a 0.1 μ F capacitor, as shown in Figure 41.



Figure 41. Decoupling V_{REF} and C_{REF}

If the internal voltage reference is to be used as a reference for external circuitry, the C_{REF} output should be used. However, a buffer must be used in this case to ensure that no current is drawn from the C_{REF} pin itself. The voltage on the C_{REF} pin is that of an internal node within the buffer block, and its voltage is critical to ADC and DAC accuracy. On the ADuC812, V_{REF} is the recommended output for the external reference; this can be used but note that there is a gain error between this reference and that of the ADC.

The ADuC832 powers up with its internal voltage reference in the on state. This is available at the V_{REF} pin, but as noted previously, there is a gain error between this and that of the ADC. The C_{REF} output becomes available when the ADC is powered up.

If an external voltage reference is preferred, it should be connected to the V_{REF} and C_{REF} pins as shown in Figure 42. Bit 6 of the ADCCON1 SFR must be set to 1 to switch in the external reference voltage.

To ensure accurate ADC operation, the voltage applied to V_{REF} must be between 1 V and AV_{DD} . In situations where analog input signals are proportional to the power supply (such as some strain gage applications), it may be desirable to connect the C_{REF} and V_{REF} pins directly to AV_{DD} .

Operation of the ADC or DACs with a reference voltage below 1 V, however, may incur loss of accuracy, eventually resulting in missing codes or nonmonotonicity. For that reason, do not use a reference voltage less than 1 V.

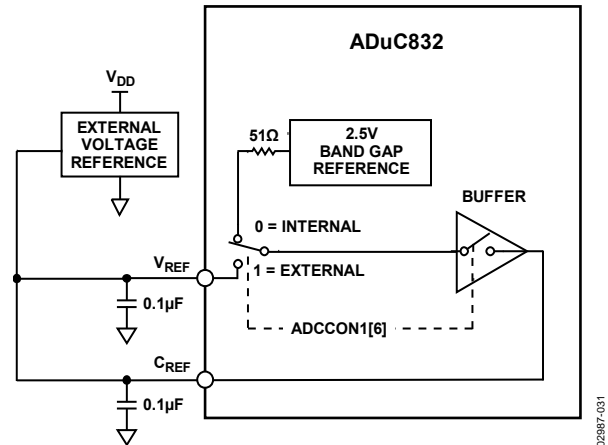

Figure 42. Using an External Voltage Reference

To maintain compatibility with the ADuC812, the external reference can also be connected to the V_{REF} pin, as shown in Figure 43, to overdrive the internal reference. Note that this introduces a gain error for the ADC that has to be calibrated out; thus the previous method is the recommended one for most users. For this method to work, ADCCON1[6] should be configured to use the internal reference. The external reference then overdrives this.

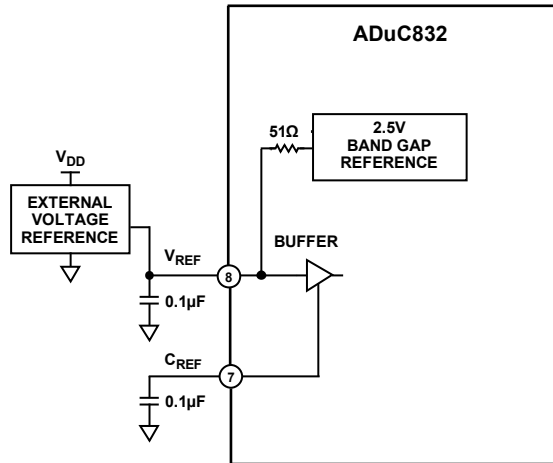

Figure 43. Using an External Voltage Reference

CONFIGURING THE ADC

The successive approximation ADC of the ADuC832 is driven by a divided down version of the master clock. To ensure adequate ADC operation, this ADC clock must be between 400 kHz and 6 MHz, and optimum performance is obtained with ADC clock between 400 kHz and 4.5 MHz. Frequencies within this range can easily be achieved with master clock frequencies from 400 kHz to well above 16 MHz with the four ADC clock divide ratios to choose from. For example, set the ADC clock divide ratio to 4 (that is, $ADCCLK = 16.78\text{ MHz}/8 = 2\text{ MHz}$) by setting the appropriate bits in ADCCON1 ($ADCCON1[5:4] = 00$).

The total ADC conversion time is 15 ADC clocks, plus 1 ADC clock for synchronization, plus the selected acquisition time (one, two, three, or four ADC clocks). For the preceding example, with a three-clock acquisition time, total conversion time is 19 ADC clocks (or 9.05 sec for a 2 MHz ADC clock).

In continuous conversion mode, a new conversion begins each time the previous one finishes. The sample rate is then simply the inverse of the total conversion time previously described. In the preceding example, the continuous conversion mode sample rate would be 110.3 kHz.

If using the temperature sensor as the ADC input, the ADC should be configured to use an ADCCLK of MCLK/32 and four acquisition clocks.

Increasing the conversion time on the temperature sensor channel improves the accuracy of the reading. To further improve the accuracy, an external reference with low temperature drift should also be used.

ADC DMA MODE

The on-chip ADC is designed to run at a maximum conversion speed of 4 µs (247 kSPS sampling rate). When converting at this rate, the ADuC832 MicroConverter® has 4 µs to read the ADC result and store the result in memory for further postprocessing; otherwise, the next ADC sample may be lost. In an interrupt driven routine, the MicroConverter also has to jump to the ADC

interrupt service routine, which also increases the time required to store the ADC results. In applications where the ADuC832 cannot sustain the interrupt rate, an ADC DMA mode is provided.

To enable DMA mode, Bit 6 in ADCCON2 (DMA) must be set. This allows the ADC results to be written directly to a 16 MB external static memory SRAM (mapped into data memory space) without any interaction from the ADuC832 core. This mode allows the ADuC832 to capture a contiguous sample stream at full ADC update rates (247 kSPS).

A Typical DMA Mode Configuration Example

To set the ADuC832 into DMA mode, a number of steps must be followed:

1. The ADC must be powered down. This is done by ensuring MD1 is set to 0 in ADCCON1.
2. The DMA address pointer must be set to the start address of where the ADC results are to be written. This is done by writing to the DMA mode address pointers DMAL, DMAH, and DMAP. DMAL must be written to first, followed by DMAH, and then by DMAP.
3. The external memory must be preconfigured. This consists of writing the required ADC channel IDs into the top four bits of every second memory location in the external SRAM, starting at the first address specified by the DMA address pointer. Because the ADC DMA mode operates independent from the ADuC832 core, it is necessary to provide it with a stop command. This is done by duplicating the last channel ID to be converted, followed by 1111 into the next channel selection field. A typical preconfiguration of external memory is as follows:

00000AH	1	1	1	1		STOP COMMAND
	0	0	1	1		REPEAT LAST CHANNEL FOR A VALID STOP CONDITION
	0	0	1	1		CONVERT ADC CH 3
	1	0	0	0		CONVERT TEMP SENSOR
	0	1	0	1		CONVERT ADC CH 5
000000H	0	0	1	0		CONVERT ADC CH 2

Figure 44. Typical DMA External Memory Preconfiguration

4. Initiate the DMA by writing to the ADC SFRs in the following sequence:
 - a. ADCCON2 is written to enable the DMA mode, that is, $MOV\ ADCCON2,\ #40H$; DMA mode enabled.
 - b. ADCCON1 is written to configure the conversion time and power-up of the ADC. It can also enable Timer 2 driven conversions or external triggered conversions if required.
 - c. ADC conversions are initiated. This is done by starting single conversions, starting Timer 2, running for Timer 2 conversions, or receiving an external trigger.

When the DMA conversions are completed, the ADC interrupt bit, ADCl, is set by hardware and the external SRAM contains the new ADC conversion results as shown in Figure 45. Note that no result is written to the last two memory locations.

When the DMA mode logic is active, it takes the responsibility of storing the ADC results away from both the user and ADuC832 core logic. As it writes the results of the ADC conversions to external memory, it takes over the external memory interface from the core. Thus, any core instructions that access the external memory while DMA mode is enabled do not gain access to it. The core executes the instructions, which take the same time to execute, but do not gain access to the external memory.

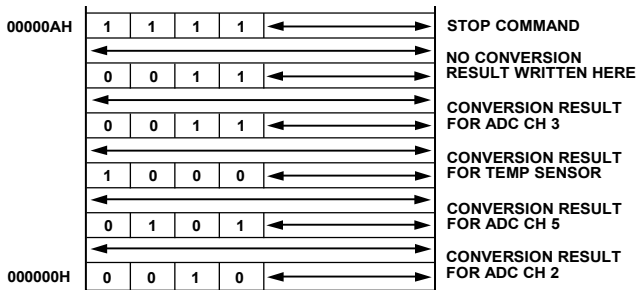

Figure 45. Typical External Memory Configuration Post-ADC DMA Operation

The DMA logic operates from the ADC clock and uses pipelining to perform the ADC conversions and to access the external memory at the same time. The time it takes to perform one ADC conversion is called a DMA cycle. The actions performed by the logic during a typical DMA cycle are shown in Figure 46.



Figure 46. DMA Cycle

From Figure 46, it can be seen that during one DMA cycle, the following actions are performed by the DMA logic:

- An ADC conversion is performed on the channel whose ID was read during the previous cycle.
- The 12-bit result and the channel ID of the conversion performed in the previous cycle is written to the external memory.
- The ID of the next channel to be converted is read from external memory.

For the previous example, the complete flow of events is shown in Figure 46. Because the DMA logic uses pipelining, it takes three cycles before the first correct result is written out.

MICRO-OPERATION DURING ADC DMA MODE

During ADC DMA mode, the MicroConverter core is free to continue code execution, including general housekeeping and communication tasks. However, note that MCU core accesses to Port 0 and Port 2 (which are being used by the DMA controller) are gated off during ADC DMA mode of operation. This means that even though the instruction that accesses the external Port 0 or Port 2 appears to execute, no data is seen at these external ports as a result. Note that during DMA to the internally contained XRAM, Port 0 and Port 2 are available for use.

The only case in which the MCU is able to access XRAM during DMA is when the internal XRAM is enabled and the section of RAM to which the DMA ADC results are being written to lies in an external XRAM. Then the MCU is able to access only the internal XRAM. This is also the case for use of the extended stack pointer.

The MicroConverter core can be configured with an interrupt to be triggered by the DMA controller when it has finished filling the requested block of RAM with ADC results, allowing the service routine for this interrupt to postprocess data without any real-time timing constraints.

ADC OFFSET AND GAIN CALIBRATION COEFFICIENTS

The ADuC832 has two ADC calibration coefficients, one for offset calibration and one for gain calibration. Both the offset and gain calibration coefficients are 14-bit words, and are each stored in two registers located in the special function register (SFR) area. The offset calibration coefficient is divided into ADCOFSH (six bits) and ADCOFSL (eight bits) and the gain calibration coefficient is divided into ADCGAINH (six bits) and ADCGAINL (eight bits).

The offset calibration coefficient compensates for dc offset errors in both the ADC and the input signal. Increasing the offset coefficient compensates for positive offset, and effectively pushes the ADC transfer function down. Decreasing the offset coefficient compensates for negative offset, and effectively pushes the ADC transfer function up. The maximum offset that can be compensated is typically $\pm 5\%$ of V_{REF} , which equates to typically ± 125 mV with a 2.5 V reference.

Similarly, the gain calibration coefficient compensates for dc gain errors in both the ADC and the input signal. Increasing the gain coefficient compensates for a smaller analog input signal range and scales the ADC transfer function up, effectively increasing the slope of the transfer function. Decreasing the gain coefficient compensates for a larger analog input signal range and scales the ADC transfer function down, effectively decreasing the slope of the transfer function. The maximum analog input signal range for which the gain coefficient can compensate is $1.025 \times V_{REF}$ and the minimum input range is $0.975 \times V_{REF}$, which equates to typically $\pm 2.5\%$ of the reference voltage.

CALIBRATING THE ADC

There are two hardware calibration modes provided that can be easily initiated by user software. The ADCCON3 SFR is used to calibrate the ADC. The typical bit (ADCCON3[1]) and the CS3 to CS0 bits (ADCCON2[3:0]) set up the calibration modes.

Device calibration can be initiated to compensate for significant changes in operating conditions frequency, analog input range, reference voltage, and supply voltages. In this calibration mode, offset calibration uses the internal AGND selected via ADCCON2 register bits CS[3:0] = 1011, and gain calibration uses the internal V_{REF} selected by CS[3:0] = 1100. Offset calibration should be executed first, followed by gain calibration.

System calibration can be initiated to compensate for both internal and external system errors. To perform system calibration using an external reference, tie system ground and reference to any two of the six selectable inputs. Enable external reference mode (ADCCON1[6]). Select the channel connected to AGND via CS[3:0] and perform system offset calibration. Select the channel connected to V_{REF} via CS[3:0] and perform system gain calibration.

The ADC should be configured to use settings for an ADCCLK of divide-by-16 and divide-by-4 acquisition clocks.

INITIATING CALIBRATION IN CODE

When calibrating the ADC using ADCCON1, the ADC should be set up into the configuration in which it will be used. The ADCCON3 register can then be used to set up the device and calibrate the ADC offset and gain.

```
MOV ADCCON1,#0ACH      ;ADC on; ADCCLK set
                        ;to divide by 16,4
                        ;acquisition clock
```

To calibrate device offset:

```
MOV ADCCON2,#0BH      ;select internal AGND
MOV ADCCON3,#25H      ;select offset calibration,
                        ;31 averages per bit,
                        ;offset calibration
```

To calibrate device gain:

```
MOV ADCCON2,#0CH      ;select internal VREF
MOV ADCCON3,#27H      ;select offset calibration,
                        ;31 averages per bit,
                        ;offset calibration
```

To calibrate system offset:

Connect system AGND to an ADC channel input (0).

```
MOV ADCCON2,#00H      ;select external AGND
MOV ADCCON3,#25H      ;select offset calibration,
                        ;31 averages per bit
```

To calibrate system gain:

Connect system V_{REF} to an ADC channel input (1).

```
MOV ADCCON2,#01H      ;select external VREF
MOV ADCCON3,#27H      ;select offset calibration
                        ;31 averages per bit,
                        ;offset calibration
```

The calibration cycle time, t_{CAL} , is calculated by the following equation:

$$t_{CAL} = 14 \times ADCCLK \times NUMAV \times (16 + t_{ACQ})$$

For an $ADCCLK/f_{CORE}$ divide ratio of 16, with $t_{ACQ} = 4 ADCCLK$, and $NUMAV = 15$, the calibration cycle time is:

$$t_{CAL} = 14 \times (1/1,048,576) \times 15 \times (16 + 4)$$

$$t_{CAL} = 4.2 \text{ ms}$$

In a calibration cycle, the ADC busy flag (ADCCON3[7]), instead of framing an individual ADC conversion as in normal mode, goes high at the start of calibration and only returns to 0 at the end of the calibration cycle. It can therefore be monitored in code to indicate when the calibration cycle is completed. The following code can be used to monitor the busy signal during a calibration cycle:

```
WAIT:
MOV A, ADCCON3          ;move ADCCON3 to A
JB ACC.7, WAIT          ;If Bit 7 is set, jump to
                        ;WAIT, else continue
```

NONVOLATILE FLASH/EE MEMORY

FLASH/EE MEMORY OVERVIEW

The ADuC832 incorporates Flash/EE memory technology on chip to provide the user with nonvolatile, in-circuit, reprogrammable code and data memory space. Flash/EE memory is a relatively recent type of nonvolatile memory technology and is based on a single transistor cell architecture.

This technology is basically an outgrowth of EPROM technology and was developed through the late 1980s. Flash/EE memory takes the flexible in-circuit reprogrammable features of EEPROM and combines them with the space efficient/density features of EPROM (see Figure 47).

Because Flash/EE technology is based on a single transistor cell architecture, a Flash memory array, like EPROM, can be implemented to achieve the space efficiencies or memory densities required by a given design. Like EEPROM, Flash memory can be programmed in-system at a byte level, although it must first be erased, the erase being performed in page blocks. Thus, Flash memory is often and more correctly referred to as Flash/EE memory.

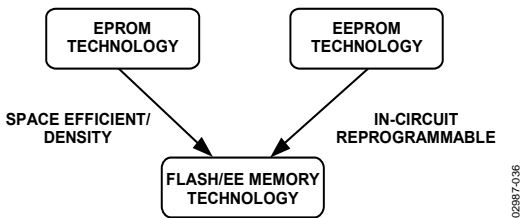

Figure 47. Flash/EE Memory Development

Overall, Flash/EE memory represents a step closer to the ideal memory device that includes nonvolatility, in-circuit programmability, high density, and low cost. Incorporated in the ADuC832, Flash/EE memory technology allows the user to update program code space in-circuit, without the need to replace one-time programmable (OTP) devices at remote operating nodes.

FLASH/EE MEMORY AND THE ADuC832

The ADuC832 provides two arrays of Flash/EE memory for user applications. There are 62 kB of Flash/EE program space provided on chip to facilitate code execution without any external discrete ROM device requirements. The program memory can be programmed in-circuit using the serial download mode provided, using conventional third party memory programmers, or via a user defined protocol that can configure it as data if required.

A 4 kB Flash/EE data memory space is also provided on chip. This can be used as a general-purpose nonvolatile scratchpad area. User access to this area is via a group of six SFRs. This space can be programmed at the byte level, although it must first be erased in 4-byte pages.

ADuC832 FLASH/EE MEMORY RELIABILITY

The Flash/EE program and data memory arrays on the ADuC832 are fully qualified for two key Flash/EE memory characteristics, namely Flash/EE memory cycling endurance and Flash/EE memory data retention.

Endurance quantifies the ability of the Flash/EE memory to be cycled through many program, read, and erase cycles. In real terms, a single Flash/EE memory endurance cycle is composed of the following four independent, sequential events:

- Initial page erase sequence
- Read/verify sequence
- Byte program sequence
- Second read/verify sequence

In reliability qualification, every byte in both the program and data Flash/EE memory is cycled from 00H to FFH until a first fail is recorded, signifying the endurance limit of the on-chip Flash/EE memory.

As indicated in the Specifications section, the ADuC832 Flash/EE memory endurance qualification has been carried out in accordance with JEDEC Specification A117 over the industrial temperature range of -40°C to $+25^{\circ}\text{C}$ and $+85^{\circ}\text{C}$ to $+125^{\circ}\text{C}$. The results allow the specification of a minimum endurance value over supply and temperature of 100,000 cycles, with an endurance value of 700,000 cycles being typical of operation at 25°C .

Retention quantifies the ability of the Flash/EE memory to retain its programmed data over time. Again, the ADuC832 has been qualified in accordance with the formal JEDEC retention lifetime specification (A117) at a specific junction temperature ($T_J = 55^{\circ}\text{C}$). As part of this qualification procedure, the Flash/EE memory is cycled to its specified endurance limit described previously, before data retention is characterized. This means that the Flash/EE memory is guaranteed to retain its data for its full specified retention lifetime every time the Flash/EE memory is reprogrammed. It should also be noted that retention lifetime, based on an activation energy of 0.6 eV, derates with T_J , as shown in Figure 48.

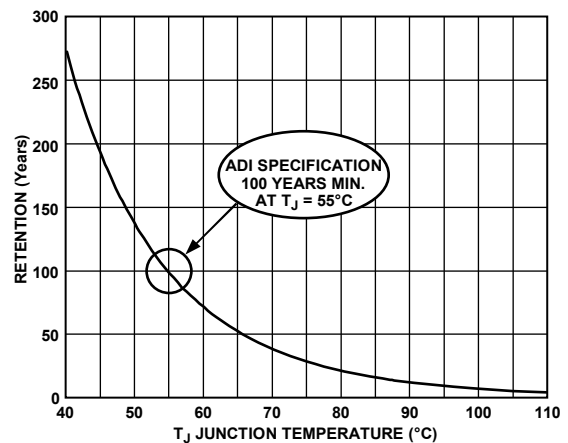

Figure 48. Flash/EE Memory Data Retention

USING THE FLASH/EE PROGRAM MEMORY

The 62 kB Flash/EE program memory array is mapped into the lower 62 kB of the 64 kB program space addressable by the ADuC832, and is used to hold user code in typical applications.

The program memory Flash/EE memory arrays can be programmed in three ways: serial downloading, parallel programming, and user download mode.

Serial Downloading (In-Circuit Programming)

The ADuC832 facilitates code download via the standard UART serial port. The ADuC832 enters serial download mode after a reset or power cycle if the PSEN pin is pulled low through an external 1 kΩ resistor. Once in serial download mode, the user can download code to the full 62 kB of Flash/EE program memory while the device is in-circuit in its target application hardware.

A PC serial download executable is provided as part of the ADuC832 QuickStart™ development system. The serial download protocol is detailed in Application Note AN-1074.

Parallel Programming

The parallel programming mode is fully compatible with conventional third-party Flash or EEPROM device programmers. In this mode, Port P0, Port P1, and Port P2 operate as the external data and address bus interface, ALE operates as the write enable strobe, and Port P3 is used as a general configuration port that configures the device for various program and erase operations during parallel programming. The high voltage (12 V) supply required for Flash programming is generated using on-chip charge pumps to supply the high voltage program lines.

The complete parallel programming specification is available at www.analog.com/microconverter, the MicroConverter home page.

User Download Mode (ULOAD)

As shown in Figure 49, it is possible to use the 62 kB of Flash/EE program memory available to the user as one single block of memory. In this mode, all of the Flash/EE memory is read only to user code.

However, the Flash/EE program memory can also be written to during run time simply by entering ULOAD mode. In ULOAD mode, the lower 56 kB of program memory can be erased and reprogrammed by user software as shown in Figure 49. ULOAD mode can be used to upgrade your code in the field via any user defined download protocol. Configuring the SPI port on the ADuC832 as a slave, it is possible to completely reprogram the 56 kB of Flash/EE program memory in only 5 seconds (see the uC007 Technical Note, *User Download (ULOAD) Mode*).

Alternatively, ULOAD mode can be used to save data to the 56 kB of Flash/EE memory. This can be extremely useful in data logging applications where the ADuC832 can provide up to 60 kB of NV data memory on chip (4 kB of dedicated Flash/EE data memory also exist).

The upper 6 kB of the 62 kB of Flash/EE program memory is only programmable via serial download or parallel programming. This means that this space appears as read only to user code. Therefore, it cannot be accidentally erased or reprogrammed by erroneous code execution. This makes it very suitable to use the 6 kB as a bootloader. A bootloader enable option exists in the serial downloader to always run from E000H after reset. If using a bootloader, this option is recommended to ensure that the bootloader always executes correct code after reset.

Programming the Flash/EE program memory via ULOAD mode is described in more detail in the ECON—Flash/EE Memory Control SFR section and in the uC007 Technical Note, *User Download (ULOAD) Mode*.



Figure 49. Flash/EE Program Memory Map in ULOAD Mode

FLASH/EE PROGRAM MEMORY SECURITY

The ADuC832 facilitates three modes of Flash/EE program memory security. These modes can be independently activated, restricting access to the internal code space. These security modes can be enabled as part of serial download protocol as described in Application Note AN-1074 or via parallel programming. The security modes available on the ADuC832 are described as follows.

Lock Mode

This mode locks the code memory, disabling parallel programming of the program memory. However, reading the memory in parallel mode and reading the memory via a MOVC command from external memory is still allowed. This mode is deactivated by initiating a code-erase command in serial download or parallel programming modes.

Secure Mode

This mode locks code in memory, disabling parallel programming (program and verify/read commands) as well as disabling the execution of a MOVC instruction from external memory, which attempts to read the op codes from internal memory. Read/write of internal data Flash/EE from external memory is also disabled. This mode is deactivated by initiating a code-erase command in serial download or parallel programming modes.

Serial Safe Mode

This mode disables serial download capability on the device. If serial safe mode is activated and an attempt is made to reset the part into serial download mode, that is, RESET asserted and deasserted with $\overline{\text{PSEN}}$ low, the part interprets the serial download reset as a normal reset only. It therefore does not enter serial download mode but only executes a normal reset sequence. Serial safe mode can only be disabled by initiating a code-erase command in parallel programming mode.

USING THE FLASH/EE DATA MEMORY

The 4 kB of Flash/EE data memory is configured as 1024 pages, each of four bytes. As with the other ADuC832 peripherals, the interface to this memory space is via a group of registers mapped in the SFR space. A group of four data registers (EDATA1 to EDATA4) are used to hold the four bytes of data at each page. The page is addressed via the EADRH and EADRL registers. Finally, ECON is an 8-bit control register that may be written with one of nine Flash/EE memory access commands to trigger various read, write, erase, and verify functions.

A block diagram of the SFR interface to the Flash/EE data memory array is shown in Figure 50.

ECON—FLASH/EE MEMORY CONTROL SFR

Programming of either the Flash/EE data memory or the Flash/EE program memory is done through the Flash/EE memory control SFR (ECON). This SFR allows the user to read, write, erase, or verify the 4 kB of Flash/EE data memory or the 56 kB of Flash/EE program memory.

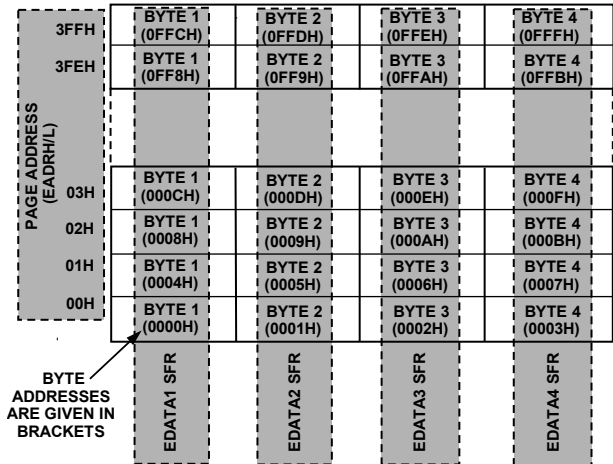

Figure 50. Flash/EE Data Memory Control and Configuration

Table 21. ECON—Flash/EE Memory Commands

ECON Value	Command Description (Normal Mode) (Power-On Default)	Command Description (ULOAD Mode)
01H READPAGE	Results in four bytes in the Flash/EE data memory, addressed by the page address EADRH/L, being read into EDATA1 to EDATA4.	Not implemented. Use the MOVC instruction.
02H WRITEPAGE	Results in four bytes in EDATA1 to EDATA4 being written to the Flash/EE data memory at the page address given by EADRH/L ¹ (0 ≤ EADRH/L < 0400H). Note that the four bytes in the page being addressed must be pre-erased.	Results in Byte 0 to Byte 255 of internal XRAM being written to the 256 bytes of Flash/EE program memory at the page address given by EADRH (0 ≤ EADRH < E0H). Note that the 256 bytes in the page being addressed must be pre-erased.
03H	Reserved command.	Reserved command.
04H VERIFYPAGE	Verifies if the data in EDATA[1:4] is contained in the page address given by EADRH/L. A subsequent read of the ECON SFR results in a 0 being read if the verification is valid, or a nonzero value being read to indicate an invalid verification.	Not implemented. Use the MOVC and MOVX instructions to verify the WRITE in software.
05H ERASEPAGE	Results in the erase of the 4-byte page of Flash/EE data memory addressed by the Page Address EADRH/L.	Results in the 64-byte page of Flash/EE program memory, addressed by the Byte Address EADRH/L being erased. EADRL can equal any of 64 locations within the page. A new page starts whenever EADRL is equal to 00H, 40H, 80H, or C0H.
06H ERASEALL	Results in the erase of entire 4 kB of Flash/EE data memory.	Results in the erase of the entire 56 kB of ULOAD Flash/EE program memory.
81H READBYTE	Results in the byte in the Flash/EE data memory, addressed by the Byte Address EADRH/L, being read into EDATA1 (0 ≤ EADRH/L ≤ 0FFFH).	Not implemented. Use the MOVC command.
82H WRITEBYTE	Results in the byte in EDATA1 being written into Flash/EE data memory, at the byte address EADRH/L.	Results in the byte in EDATA1 being written into Flash/EE program memory, at the Byte Address EADRH/L (0 ≤ EADRH/L ≤ DFFFH).
0FH EXULOAD	Leaves the ECON instructions to operate on the Flash/EE data memory.	Enters normal mode directing subsequent ECON instructions to operate on the Flash/EE data memory.
F0H ULOAD	Enters ULOAD mode, directing subsequent ECON instructions to operate on the Flash/EE program memory.	Leaves the ECON instructions to operate on the Flash/EE program memory.

¹ Register EADRH and EADRL form the full address, EADRH/L.

EXAMPLE: PROGRAMMING THE FLASH/EE DATA MEMORY

To program F3H into the second byte on Page 03H of the Flash/EE data memory space while preserving the other three bytes already in this page, a typical program of the Flash/EE data array includes the following steps:

1. Setting EADRH/L with the page address
2. Writing the data to be programmed to EDATA1 to EDATA4
3. Writing the ECON SFR with the appropriate command

Step 1: Set Up the Page Address

The two address registers, EADRH and EADRL, hold the high byte address and the low byte address of the page to be addressed.

The assembly language to set up the address may appear as:

```
MOV EADRH,#0      ; Set Page Address Pointer
MOV EADRL,#03H
```

Step 2: Set Up the EDATA Registers

Next, write the four values to be written into the page into the four SFRs, EDATA1 to EDATA4. Unfortunately, three of these are unknown. Thus, the current page must be read and the second byte overwritten.

```
MOV ECON,#1      ; Read Page into EDATA1 to
                  EDATA4
MOV EDATA2,#0F3H ; Overwrite Byte 2
```

Step 3: Program Page

A byte in the Flash/EE array can only be programmed if it has previously been erased; that is, a byte can only be programmed if it already holds the value FFH. Because of the Flash/EE architecture, this erase must happen at a page level; therefore, a minimum of four bytes (one page) is erased when an erase command is initiated. Once the page is erased, the four bytes can be programmed in-page and then a verification of the data performed.

```
MOV ECON,#5      ; ERASE Page
MOV ECON,#2      ; WRITE Page
MOV ECON,#4      ; VERIFY Page
MOV A,ECON       ; Check if ECON = 0 (OK!)
JNZ ERROR
```

Although the 4 kB of Flash/EE data memory are shipped from the factory pre-erased, that is, byte locations set to FFH, it is

nonetheless good programming practice to include an erase-all routine as part of any configuration/setup code running on the ADuC832. An erase all command consists of writing 06H to the ECON SFR, which initiates an erase of the 4 kB Flash/EE array. This command coded in 8051 assembly appears as:

```
MOV ECON,#06H    ; Erase all Command
                  ; 2 ms Duration
```

FLASH/EE MEMORY TIMING

Typical program and erase times for the ADuC832 are as detailed in Table 22 and Table 23.

Table 22. Normal Mode (Operating on Flash/EE Data Memory)

Instruction	Time
READPAGE (4 bytes)	–5 machine cycles
WRITEPAGE (4 bytes)	–380 μ s
VERIFYPAGE (4 bytes)	–5 machine cycles
ERASEPAGE (4 bytes)	–2 ms
ERASEALL (4 kB)	–2 ms
READBYTE (1 byte)	–3 machine cycle
WRITEBYTE (1 byte)	–200 μ s

Table 23. ULOAD Mode (Operating on Flash/EE Program Memory)

Instruction	Time
WRITEPAGE (256 bytes)	–15 ms
ERASEPAGE (64 bytes)	–2 ms
ERASEALL (56 kB)	–2 ms
WRITEBYTE (1 byte)	–200 μ s

Note that a given mode of operation is initiated as soon as the command word is written to the ECON SFR. The core microcontroller operation on the ADuC832 is idled until the requested program/read or erase mode is completed.

In practice, this means that even though the Flash/EE memory mode of operation is typically initiated with a two-machine cycle MOV instruction (to write to the ECON SFR), the next instruction is not executed until the Flash/EE operation is complete. This means that the core does not respond to interrupt requests until the Flash/EE operation is complete, although the core peripheral functions such as counter/timers continue to count and keep time as configured throughout this period.

ADUC832 CONFIGURATION SFR (CFG832)

The CFG832 SFR contains the necessary bits to configure the internal XRAM, external clock select, PWM output selection, DAC buffer, and the extended SP. By default, it configures the user into 8051 mode; that is, extended SP is disabled and the internal XRAM is disabled.

CFG832 (ADuC832 Configuration SFR)

SFR Address: AFH
 Power-On Default Value: 00H
 Bit Addressable: No

Table 24. CFG832 SFR Bit Designations

Bit	Name	Description
[7]	EXSP	Extended SP enable. When set to 1 by the user, the stack rolls over from SPH/SP = 00FFH to SPH/SP = 0100H. When set to 0 by the user, the stack rolls over from SP = FFH to SP = 00H.
[6]	PWPO	PWM pinout selection. When set to 1 by the user, the PWM output pins are selected as P3.4 and P3.3. When set to 0 by the user, the PWM output pins are selected as P2.6 and P2.7.
[5]	DBUF	DAC output buffer. When set to 1 by the user, the DAC output buffer is bypassed. When set to 0 by the user, the DAC output buffer is enabled.
[4]	EXTCLK	Set by the user to 1 to select an external clock input on P3.4. Set by the user to 0 to use the internal PLL clock.
[3]	RSVD	Reserved. This bit should always contain 0.
[2]	RSVD	Reserved. This bit should always contain 0.
[1]	RSVD	Reserved. This bit should always contain 0.
[0]	XRAMEN	XRAM enable bit. When set to 1 by the user, the internal XRAM is mapped into the lower 2 kB of the external address space. When set to 0 by the user, the internal XRAM is not accessible and the external data memory is mapped into the lower 2 kB of external data memory.

USER INTERFACE TO OTHER ON-CHIP ADuC832 PERIPHERALS

The following section gives a brief overview of the various peripherals also available on-chip. A summary of the SFRs used to control and configure these peripherals is also given.

DAC

The ADuC832 incorporates two 12-bit voltage output DACs on chip. Each DAC has a rail-to-rail voltage output buffer capable of driving 10 k Ω /100 pF. Each has two selectable ranges, 0 V to V_{REF} (the internal band gap 2.5 V reference) and 0 V to AV_{DD} .

Each can operate in 12-bit or 8-bit mode. Both DACs share a control register, DACCON, and four data registers, DAC1H, DAC1L, DAC0H, and DAC0L. Note that in 12-bit asynchronous mode, the DAC voltage output is updated as soon as the DACL data SFR has been written; therefore, the DAC data registers should be updated as DACH first, followed by DACL. Note that for correct DAC operation on the 0 V to V_{REF} range, the ADC must be switched on. This results in the DAC using the correct reference value.

DACCON (DAC Control Register)

SFR Address: FDH

Power-On Default Value: 04H

Bit Addressable: No

DACxH/DACxL (DAC Data Registers)

Function: DAC data registers, written by user to update the DAC output

SFR Address: DAC0L (DAC0 data low byte) = F9H;
DAC1L (DAC1 data low byte) = FBH

DAC0H (DAC0 data high byte) = FAH;
DAC1H (DAC1 data high byte) = FCH

Power-On Default Value: 00H (all four registers)

Bit Addressable: No (all four registers)

The 12-bit DAC data should be written into DACxH/DACxL right-justified such that DACxL contains the lower eight bits, and the lower nibble of DACxH contains the upper four bits.

Table 25. DACCON SFR Bit Designations

Bit	Name	Description
[7]	Mode	The DAC MODE bit sets the overriding operating mode for both DACs. Set to 1 = 8-bit mode (write eight bits to DACxL SFR). Set to 0 = 12-bit mode.
[6]	RNG1	DAC1 range select bit. Set to 1 = DAC1 range 0 V – V_{DD} . Set to 0 = DAC1 range 0 V – V_{REF} .
[5]	RNG0	DAC0 range select bit. Set to 1 = DAC0 range 0 V – V_{DD} . Set to 0 = DAC0 range 0 V – V_{REF} .
[4]	CLR1	DAC1 clear bit. Set to 0 = DAC1 output forced to 0 V. Set to 1 = DAC1 output normal.
[3]	CLR0	DAC0 clear bit. Set to 0 = DAC1 Output Forced to 0 V. Set to 1 = DAC1 output normal.
[2]	SYNC	DAC0/DAC1 update synchronization bit. When set to 1, the DAC outputs update as soon as DACxL SFRs are written. The user can simultaneously update both DACs by first updating the DACxL/DACxH SFRs while SYNC is 0. Both DACs then update simultaneously when the SYNC bit is set to 1.
[1]	$\overline{PD1}$	DAC1 Power-down bit. Set to 1 = power on DAC1. Set to 0 = power off DAC1.
[0]	PD0	DAC0 Power-Down Bit. Set to 1 = power on DAC0. Set to 0 = power off DAC0.

USING THE DAC

The on-chip DAC architecture consists of a resistor string DAC followed by an output buffer amplifier, the functional equivalent of which is illustrated in Figure 51. Details of the actual DAC architecture can be found in U.S. Patent Number 5,969,657. Features of this architecture include inherent guaranteed monotonicity and excellent differential linearity.

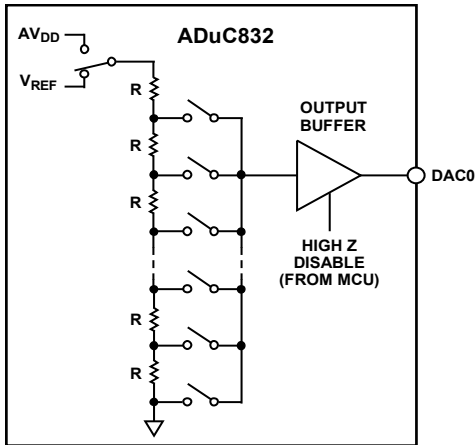

Figure 51. Resistor String DAC Functional Equivalent

As illustrated in Figure 51, the reference source for each DAC is user selectable in software. It can be either AV_{DD} or V_{REF} . In 0 V to AV_{DD} mode, the DAC output transfer function spans from 0 V to the voltage at the AV_{DD} pin. In 0 V to V_{REF} mode, the DAC output transfer function spans from 0 V to the internal V_{REF} or, if an external reference is applied, the voltage at the V_{REF} pin. The DAC output buffer amplifier features a true rail-to-rail output stage implementation. This means that, unloaded, each output is capable of swinging to within less than 100 mV of both AV_{DD} and ground. Moreover, the DAC's linearity specification (when driving a 10 k Ω resistive load to ground) is guaranteed through the full transfer function except Code 0 to Code 100, and, in 0 V to AV_{DD} mode only, Code 3995 to Code 4095. Linearity degradation near ground and AV_{DD} is caused by saturation of the output amplifier, and a general representation of its effects (neglecting offset and gain error) is illustrated in Figure 52. The dotted line in Figure 52 indicates the ideal transfer function, and the solid line represents what the transfer function may look like with endpoint nonlinearities due to saturation of the output amplifier. Note that Figure 52 represents a transfer function in 0 V to AV_{DD} mode only. In 0 V to V_{REF} mode (with $V_{REF} < AV_{DD}$), the lower nonlinearity is similar, but the upper portion of the transfer function follows the ideal line to the end (V_{REF} in this case, not AV_{DD}), showing no signs of endpoint linearity errors.



Figure 52. Endpoint Nonlinearities Due to Amplifier Saturation

The endpoint nonlinearities conceptually illustrated in Figure 52 become worse as a function of output loading. Most of the ADuC832 specifications assume a 10 k Ω resistive load to ground at the DAC output. As the output is forced to source or sink more current, the nonlinear regions at the top or bottom (respectively) of Figure 52 become larger. With larger current demands, this can significantly limit output voltage swing. Figure 53 and Figure 54 illustrate this behavior. It should be noted that the upper trace in each of these figures is only valid for an output range selection of 0 V to AV_{DD} . In 0 V to V_{REF} mode, DAC loading does not cause high-side voltage drops as long as the reference voltage remains below the upper trace in the corresponding figure. For example, if $AV_{DD} = 3$ V and $V_{REF} = 2.5$ V, the high-side voltage is not affected by loads less than 5 mA. However, around 7 mA, the upper curve in Figure 54 drops below 2.5 V (V_{REF}), indicating that, at these higher currents, the output is not capable of reaching V_{REF} .

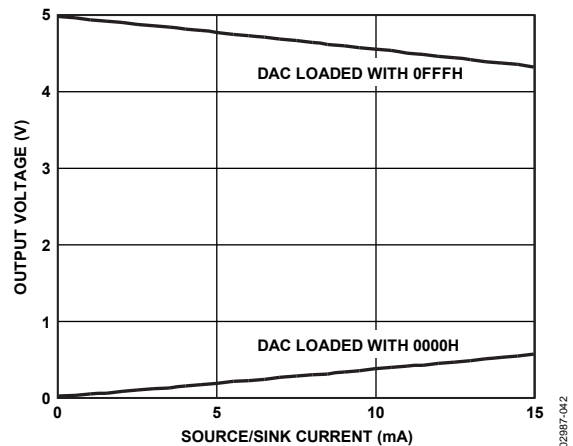

Figure 53. Source and Sink Current Capability with $V_{REF} = AV_{DD} = 5$ V

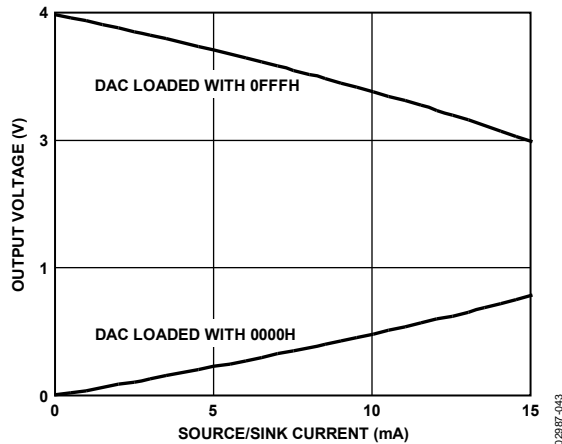

Figure 54. Source and Sink Current Capability with $V_{REF} = AV_{DD} = 3V$

To reduce the effects of the saturation of the output amplifier at values close to ground and to give reduced offset and gain errors, the internal buffer can be bypassed. This is done by setting the DBUF bit in the CFG832 register. This allows a full rail-to-rail output from the DAC, which should then be buffered externally using a dual-supply op amp to obtain a rail-to-rail output. This external buffer should be located as near as physically possible to the DAC output pin on the PCB. Note that the unbuffered mode only works in the 0 V to V_{REF} range.

To drive significant loads with the DAC outputs, external buffering may be required (even with the internal buffer enabled), as illustrated in Figure 55. A list of recommended op amps is shown in Table 20.

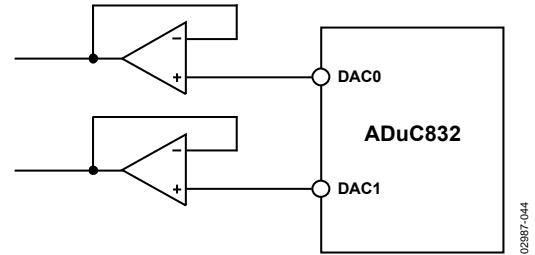

Figure 55. Buffering the DAC Outputs

The DAC output buffer also features a high impedance disable function. In the chip's default power-on state, both DACs are disabled, and their outputs are in a high impedance state (or three-state) where they remain inactive until enabled in software. This means that if a zero output is desired during power-up or power-down transient conditions, then a pull-down resistor must be added to each DAC output. Assuming this resistor is in place, the DAC outputs remain at ground potential whenever the DAC is disabled.

ON-CHIP PLL

The ADuC832 is intended for use with a 32.768 kHz watch crystal. A PLL locks onto a multiple (512) of this to provide a stable 16.78 MHz clock for the system. The core can operate at this frequency or at binary submultiples of it to allow power saving in cases where maximum core performance is not required. The default core clock is the PLL clock divided by 8 or 2.097152 MHz. The ADC clocks are also derived from the PLL clock, with the modulator rate being the same as the crystal oscillator frequency. The choice of frequencies ensures that the

modulators and the core are synchronous, regardless of the core clock rate. The PLL control register is PLLCON.

PLLCON (PLL CONTROL REGISTER)

SFR Address:	D7H
Power-On Default Value:	53H
Bit Addressable:	No

Table 26. PLLCON SFR Bit Designations

Bit	Name	Description																																				
[7]	OSC_PD	Oscillator power-down bit. Set by user to halt the 32 kHz oscillator in power-down mode. Cleared by user to enable the 32 kHz oscillator in power-down mode. This feature allows the TIC to continue counting even in power-down mode.																																				
[6]	LOCK	PLL lock bit. This is a read-only bit. Set automatically at power-on to indicate the PLL loop is correctly tracking the crystal clock. If the external crystal becomes subsequently disconnected, the PLL rails and the core halt. Cleared automatically at power-on to indicate the PLL is not correctly tracking the crystal clock. This may be due to the absence of a crystal clock or an external crystal at power-on. In this mode, the PLL output can be 16.78 MHz \pm 20%.																																				
[5]	Reserved	Reserved for future use; should be written with 0.																																				
[4]	Reserved	Reserved for future use; should be written with 0.																																				
[3]	FINT	Fast interrupt response bit. Set by user, enabling the response to any interrupt to be executed at the fastest core clock frequency, regardless of the configuration of the CD[2:0] bits. Once user code has returned from an interrupt, the core resumes code execution at the core clock selected by the CD[2:0] bits. Cleared by user to disable the fast interrupt response feature.																																				
[2:0]	CD[2:0]	CPU (core clock) divider bits. These bits determine the frequency at which the microcontroller core operates.																																				
		<table border="1"> <thead> <tr> <th>CD2</th> <th>CD1</th> <th>CD0</th> <th>Core Clock Frequency, f_{CORE} (MHz)</th> </tr> </thead> <tbody> <tr> <td>0</td> <td>0</td> <td>0</td> <td>16.78</td> </tr> <tr> <td>0</td> <td>0</td> <td>1</td> <td>8.388608</td> </tr> <tr> <td>0</td> <td>1</td> <td>0</td> <td>4.194304</td> </tr> <tr> <td>0</td> <td>1</td> <td>1</td> <td>2.097152 (default core clock frequency)</td> </tr> <tr> <td>1</td> <td>0</td> <td>0</td> <td>1.048576</td> </tr> <tr> <td>1</td> <td>0</td> <td>1</td> <td>0.524288</td> </tr> <tr> <td>1</td> <td>1</td> <td>0</td> <td>0.262144</td> </tr> <tr> <td>1</td> <td>1</td> <td>1</td> <td>0.131072</td> </tr> </tbody> </table>	CD2	CD1	CD0	Core Clock Frequency, f_{CORE} (MHz)	0	0	0	16.78	0	0	1	8.388608	0	1	0	4.194304	0	1	1	2.097152 (default core clock frequency)	1	0	0	1.048576	1	0	1	0.524288	1	1	0	0.262144	1	1	1	0.131072
CD2	CD1	CD0	Core Clock Frequency, f_{CORE} (MHz)																																			
0	0	0	16.78																																			
0	0	1	8.388608																																			
0	1	0	4.194304																																			
0	1	1	2.097152 (default core clock frequency)																																			
1	0	0	1.048576																																			
1	0	1	0.524288																																			
1	1	0	0.262144																																			
1	1	1	0.131072																																			

PULSE-WIDTH MODULATOR (PWM)

The PWM on the ADuC832 is a highly flexible PWM offering programmable resolution and an input clock, and can be configured for any one of six different modes of operation. Two of these modes allow the PWM to be configured as a Σ - Δ DAC with up to 16 bits of resolution. A block diagram of the PWM is shown in Figure 56.



Figure 56. PWM Block Diagram

The PWM uses five SFRs: the control SFR (PWMCON) and four data SFRs (PWM0H, PWM0L, PWM1H, and PWM1L).

PWMCON (as described in Table 27) controls the different modes of operation of the PWM as well as the PWM clock frequency. PWM0H/PWM0L and PWM1H/PWM1L are the data

registers that determine the duty cycles of the PWM outputs. The output pins that the PWM uses are determined by the CFG832 register, and can be either P2.6 and P2.7 or P3.4 and P3.3. In this section of the data sheet, it is assumed that P2.6 and P2.7 are selected as the PWM outputs.

To use the PWM user software, first write to PWMCON to select the PWM mode of operation and the PWM input clock. Writing to PWMCON also resets the PWM counter. In any of the 16-bit modes of operation (Mode 1, Mode 3, Mode 4, and Mode 6), user software should write to the PWM0L or PWM1L SFR first. This value is written to a hidden SFR. Writing to the PWM0H or PWM1H SFRs updates both the PWMxH and the PWMxL SFRs but does not change the outputs until the end of the PWM cycle in progress. The values written to these 16-bit registers are then used in the next PWM cycle.

PWMCON (PWM CONTROL SFR)

SFR Address: AEH
 Power-On Default Value: 00H
 Bit Addressable: No

Table 27. PWMCON SFR Bit Designations

Bit	Name	Description																																				
[7]	SNGL	Turns off PWM output at P2.6 or P3.4, leaving port pin free for digital I/O.																																				
[6:4]	MD[2:0]	PWM mode bits. The MD[2:0] bits choose the PWM mode as follows:																																				
		<table border="1"> <thead> <tr> <th>MD2</th> <th>MD1</th> <th>MD0</th> <th>Mode</th> </tr> </thead> <tbody> <tr> <td>0</td> <td>0</td> <td>0</td> <td>Mode 0: PWM disabled</td> </tr> <tr> <td>0</td> <td>0</td> <td>1</td> <td>Mode 1: single variable resolution PWM on P2.7 or P3.3</td> </tr> <tr> <td>0</td> <td>1</td> <td>0</td> <td>Mode 2: twin 8-bit PWM</td> </tr> <tr> <td>0</td> <td>1</td> <td>1</td> <td>Mode 3: twin 16-bit PWM</td> </tr> <tr> <td>1</td> <td>0</td> <td>0</td> <td>Mode 4: dual NRZ 16-bit Σ-Δ DAC</td> </tr> <tr> <td>1</td> <td>0</td> <td>1</td> <td>Mode 5: dual 8-bit PWM</td> </tr> <tr> <td>1</td> <td>1</td> <td>0</td> <td>Mode 6: dual RZ 16-bit Σ-Δ DAC</td> </tr> <tr> <td>1</td> <td>1</td> <td>1</td> <td>Reserved for future use</td> </tr> </tbody> </table>	MD2	MD1	MD0	Mode	0	0	0	Mode 0: PWM disabled	0	0	1	Mode 1: single variable resolution PWM on P2.7 or P3.3	0	1	0	Mode 2: twin 8-bit PWM	0	1	1	Mode 3: twin 16-bit PWM	1	0	0	Mode 4: dual NRZ 16-bit Σ - Δ DAC	1	0	1	Mode 5: dual 8-bit PWM	1	1	0	Mode 6: dual RZ 16-bit Σ - Δ DAC	1	1	1	Reserved for future use
MD2	MD1	MD0	Mode																																			
0	0	0	Mode 0: PWM disabled																																			
0	0	1	Mode 1: single variable resolution PWM on P2.7 or P3.3																																			
0	1	0	Mode 2: twin 8-bit PWM																																			
0	1	1	Mode 3: twin 16-bit PWM																																			
1	0	0	Mode 4: dual NRZ 16-bit Σ - Δ DAC																																			
1	0	1	Mode 5: dual 8-bit PWM																																			
1	1	0	Mode 6: dual RZ 16-bit Σ - Δ DAC																																			
1	1	1	Reserved for future use																																			
[3:2]	CDIV[1:0]	PWM clock divider. These bits scale the clock source for the PWM counter as follows:																																				
		<table border="1"> <thead> <tr> <th>CDIV1</th> <th>CDIV0</th> <th>PWM Counter</th> </tr> </thead> <tbody> <tr> <td>0</td> <td>0</td> <td>Selected clock/1</td> </tr> <tr> <td>0</td> <td>1</td> <td>Selected clock/4</td> </tr> <tr> <td>1</td> <td>0</td> <td>Selected clock/16</td> </tr> <tr> <td>1</td> <td>1</td> <td>Selected clock/64</td> </tr> </tbody> </table>	CDIV1	CDIV0	PWM Counter	0	0	Selected clock/1	0	1	Selected clock/4	1	0	Selected clock/16	1	1	Selected clock/64																					
CDIV1	CDIV0	PWM Counter																																				
0	0	Selected clock/1																																				
0	1	Selected clock/4																																				
1	0	Selected clock/16																																				
1	1	Selected clock/64																																				
[1:0]	CSEL[1:0]	PWM clock divider. These bits select the clock source for the PWM as follows:																																				
		<table border="1"> <thead> <tr> <th>CSEL1</th> <th>CSEL0</th> <th>PWM Clock</th> </tr> </thead> <tbody> <tr> <td>0</td> <td>0</td> <td>$f_{XTAL}/15$</td> </tr> <tr> <td>0</td> <td>1</td> <td>f_{XTAL}</td> </tr> <tr> <td>1</td> <td>0</td> <td>External input at P3.4/T0</td> </tr> <tr> <td>1</td> <td>1</td> <td>$f_{VCO} = 16.78 \text{ MHz}$</td> </tr> </tbody> </table>	CSEL1	CSEL0	PWM Clock	0	0	$f_{XTAL}/15$	0	1	f_{XTAL}	1	0	External input at P3.4/T0	1	1	$f_{VCO} = 16.78 \text{ MHz}$																					
CSEL1	CSEL0	PWM Clock																																				
0	0	$f_{XTAL}/15$																																				
0	1	f_{XTAL}																																				
1	0	External input at P3.4/T0																																				
1	1	$f_{VCO} = 16.78 \text{ MHz}$																																				

PWM MODES OF OPERATION

MODE 0: PWM DISABLED

The PWM is disabled, allowing P2.6 and P2.7 to be used as normal.

MODE 1: SINGLE VARIABLE RESOLUTION PWM

In Mode 1, both the pulse length and the cycle time (period) are programmable in user code, allowing the resolution of the PWM to be variable.

PWM1H/PWM1L sets the period of the output waveform. Reducing PWM1H/PWM1L reduces the resolution of the PWM output but increases the maximum output rate of the PWM. (for example, setting PWM1H/PWM1L to 65,536 gives a 16-bit PWM with a maximum output rate of 266 Hz (16.78 MHz/65,536). Setting PWM1H/PWM1L to 4096 gives a 12-bit PWM with a maximum output rate of 4096 Hz (16.78 MHz/4096).

PWM0H/PWM0L sets the duty cycle of the PWM output waveform, as shown in Figure 57.

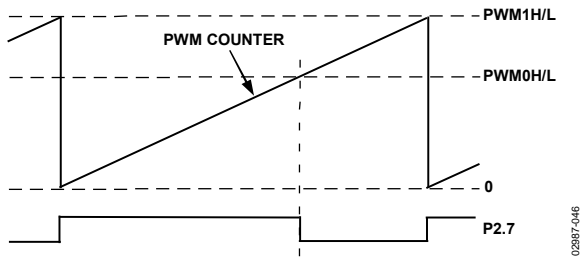

Figure 57. PWM Mode 1

MODE 2: TWIN 8-BIT PWM

In Mode 2, the duty cycle of the PWM outputs and the resolution of the PWM outputs are both programmable. The maximum resolution of the PWM output is eight bits.

PWM1L sets the period for both PWM outputs. Typically, this is set to 255 (FFH) to give an 8-bit PWM although it is possible to reduce this as necessary. A value of 100 can be loaded here to give a percentage PWM (that is, the PWM is accurate to 1%).

The outputs of the PWM at P2.6 and P2.7 are shown in Figure 58.

As can be seen, the output of PWM0 (P2.6) goes low when the PWM counter equals PWM0L. The output of PWM1 (P2.7) goes high when the PWM counter equals PWM1H and goes low again when the PWM counter equals PWM0H. Setting PWM1H to 0 ensures that both PWM outputs start simultaneously.



Figure 58. PWM Mode 2

MODE 3: TWIN 16-BIT PWM

In Mode 3, the PWM counter is fixed to count from 0 to 65,536, giving a fixed 16-bit PWM. Operating from the 16.78 MHz core clock results in a PWM output rate of 256 Hz. The duty cycle of the PWM outputs at P2.6 and P2.7 is independently programmable.

As shown in Figure 59, while the PWM counter is less than PWM0H/PWM0L, the output of PWM0 (P2.6) is high. Once the PWM counter equals PWM0H/PWM0L, PWM0 (P2.6) goes low and remains low until the PWM counter rolls over.

Similarly, while the PWM counter is less than PWM1H/PWM1L, the output of PWM1 (P2.7) is high. Once the PWM counter equals PWM1H/PWM1L, PWM1 (P2.7) goes low and remains low until the PWM counter rolls over.

In this mode, both PWM outputs are synchronized, that is, once the PWM counter rolls over to 0, both PWM0 (P2.6) and PWM1 (P2.7) go high.

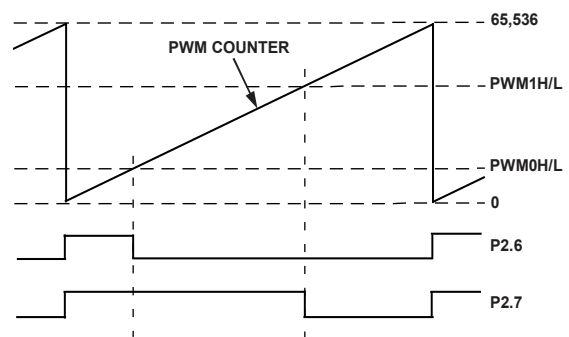

Figure 59. PWM Mode 3

MODE 4: DUAL NRZ 16-BIT Σ - Δ DAC

Mode 4 provides a high speed PWM output similar to that of a Σ - Δ DAC. Typically, this mode is used with the PWM clock equal to 16.777216 MHz.

In this mode, P2.6 and P2.7 are updated every PWM clock (60 ns in the case of 16 MHz). Over every 65,536 cycles (16-bit PWM) PWM0 (P2.6) is high for PWM0H/PWM0L cycles and low for (65,536 – PWM0H/L) cycles. Similarly PWM1 (P2.7) is high for PWM1H/PWM1L cycles and low for (65,536 – PWM1H/PWM1L) cycles.

For example, if PWM1H/L was set to 4010H (slightly above one quarter of FS), then typically P2.7 is low for three clocks and high for one clock (each clock is approximately 60 ns). Over every 65,536 clocks, the PWM compensates for the fact that the output should be slightly above one quarter of full scale by having a high cycle followed by only two low cycles.



Figure 60. PWM Mode 4

For faster DAC outputs (at lower resolution) write 0s to the LSBs that are not required. If, for example, only 12-bit performance is required, then write 0s to the four LSBs. This means that a 12-bit accurate Σ - Δ DAC output can occur at 4.096 kHz. Similarly, writing 0s to the eight LSBs gives an 8-bit accurate Σ - Δ DAC output at 65 kHz.

MODE 5: DUAL 8-BIT PWM

In Mode 5, the duty cycle of the PWM outputs and the resolution of the PWM outputs are individually programmable. The maximum resolution of the PWM output is eight bits. The output resolution is set by the PWM1L and PWM1H SFRs for the P2.6 and P2.7 outputs, respectively. PWM0L and PWM0H set the duty cycles of the PWM outputs at P2.6 and P2.7, respectively. Both PWMs have same clock source and clock divider.



Figure 61. PWM Mode 5

MODE 6: DUAL RZ 16-BIT Σ - Δ DAC

Mode 6 provides a high speed PWM output similar to that of a Σ - Δ DAC. Mode 6 operates very similarly to Mode 4. However, the key difference is that Mode 6 provides return-to-zero (RZ) Σ - Δ DAC output. Mode 4 provides nonreturn-to-zero Σ - Δ DAC outputs. The RZ mode ensures that any difference in the rise and fall times does not affect the Σ - Δ DAC INL. However, the RZ mode halves the dynamic range of the Σ - Δ DAC outputs from 0 V – AV_{DD} down to 0 V – AV_{DD}/2. For best results, this mode should be used with a PWM clock divider of four.

If PWM1H is set to 4010H (slightly above one quarter of FS) then typically P2.7 is low for three full clocks (3 × 60 ns), high for half a clock (30 ns), and then low again for half a clock (30 ns) before repeating itself. Over every 65,536 clocks, the PWM compensates for the fact that the output should be slightly above one quarter of full scale by occasionally leaving the output high for two half clocks in four.

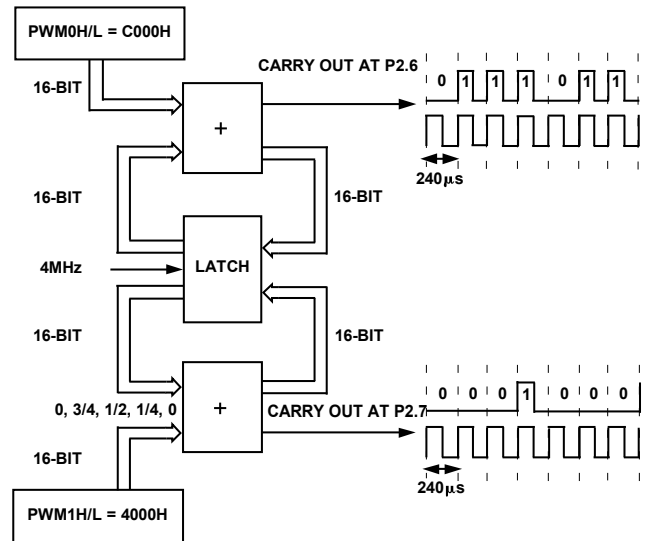

Figure 62. PWM Mode 6

SERIAL PERIPHERAL INTERFACE

The ADuC832 integrates a complete hardware serial peripheral interface (SPI) on chip. SPI is an industry standard synchronous serial interface that allows eight bits of data to be synchronously transmitted and received simultaneously, that is, full duplex. It should be noted that the SPI pins are shared with the I²C pins. Therefore, the user can only enable one or the other interface at any given time (see SPE in Table 28). The SPI port can be configured for master or slave operation and typically consists of four pins: MISO, MOSI, SCLOCK, and SS.

MISO (MASTER INPUT, SLAVE OUTPUT DATA PIN)

The MISO (master input, slave output) pin is configured as an input line in master mode and an output line in slave mode. The MISO line on the master (data in) should be connected to the MISO line in the slave device (data out). The data is transferred as byte-wide (8-bit) serial data, MSB first.

MOSI (MASTER OUTPUT, SLAVE INPUT PIN)

The MOSI (master output, slave input) pin is configured as an output line in master mode and an input line in slave mode. The MOSI line on the master (data out) should be connected to the MOSI line in the slave device (data in). The data is transferred as byte-wide (8-bit) serial data, MSB first.

SCLOCK (SERIAL CLOCK I/O PIN)

The master serial clock (SCLOCK) is used to synchronize the data being transmitted and received through the MOSI and MISO data lines. A single data bit is transmitted and received in each SCLOCK period. Therefore, a byte is transmitted/received after eight SCLOCK periods. The SCLOCK pin is configured as an output in master mode and as an input in slave mode. In master mode, the bit rate, polarity, and phase of the clock are controlled by the CPOL, CPHA, SPR0, and SPR1 bits in the

SPICON SFR (see Table 28). In slave mode, the SPICON register must be configured with the phase and polarity (CPHA and CPOL) of the expected input clock. In both master and slave modes, the data is transmitted on one edge of the SCLOCK signal and sampled on the other. It is important therefore that the CPHA and CPOL are configured the same for the master and slave devices.

SS (SLAVE SELECT INPUT PIN)

The slave select (\overline{SS}) input pin is shared with the ADC5 input. To configure this pin as a digital input, the bit must be cleared, for example, CLR P1.5.

This line is active low. Data is only received or transmitted in slave mode when the \overline{SS} pin is low, allowing the ADuC832 to be used in single master, multislave SPI configurations. If CPHA = 1, then the \overline{SS} input may be permanently pulled low. With CPHA = 0, the \overline{SS} input must be driven low before the first bit in a byte-wide transmission or reception, and return high again after the last bit in that byte-wide transmission or reception. In SPI slave mode, the logic level on the external \overline{SS} pin can be read via the SPR0 bit in the SPICON SFR.

The following SFR registers (SPICON and SPIDAT) are used to control the SPI interface.

SPICON (SPI Control Register)

SFR Address:	F8H
Power-On Default Value:	04H
Bit Addressable:	Yes

Table 28. SPICON SFR Bit Designations

Bit	Name	Description															
[7]	ISPI	SPI interrupt bit. Set by MicroConverter at the end of each SPI transfer. Cleared directly by user code or indirectly by reading the SPIDAT SFR.															
[6]	WCOL	Write collision error bit. Set by MicroConverter if SPIDAT is written to while an SPI transfer is in progress. Cleared by user code.															
[5]	SPE	SPI interface enable bit. Set by user to enable the SPI interface. Cleared by user to enable the I ² C pins.															
[4]	SPIM	SPI master/slave mode select bit. Set by user to enable Master Mode operation (SCLOCK is an output). Cleared by user to enable slave mode operation (SCLOCK is an input).															
[3]	CPOL ¹	Clock polarity select bit. Set by user if SCLOCK idles high. Cleared by user if SCLOCK idles low.															
[2]	CPHA ¹	Clock phase select bit. Set by user if leading SCLOCK edge is to transmit data. Cleared by user if trailing SCLOCK edge is to transmit data.															
[1:0]	SPR[1:0]	SPI bit rate select bits. These bits select the SCLOCK rate (bit rate) in master mode as follows:															
		<table border="1"> <thead> <tr> <th>SPR1</th> <th>SPR0</th> <th>Selected Bit Rate</th> </tr> </thead> <tbody> <tr> <td>0</td> <td>0</td> <td>$f_{osc}/2$</td> </tr> <tr> <td>0</td> <td>1</td> <td>$f_{osc}/4$</td> </tr> <tr> <td>1</td> <td>0</td> <td>$f_{osc}/8$</td> </tr> <tr> <td>1</td> <td>1</td> <td>$f_{osc}/16$</td> </tr> </tbody> </table>	SPR1	SPR0	Selected Bit Rate	0	0	$f_{osc}/2$	0	1	$f_{osc}/4$	1	0	$f_{osc}/8$	1	1	$f_{osc}/16$
SPR1	SPR0	Selected Bit Rate															
0	0	$f_{osc}/2$															
0	1	$f_{osc}/4$															
1	0	$f_{osc}/8$															
1	1	$f_{osc}/16$															
		In SPI slave mode, that is, SPIM = 0, the logic level on the external \overline{SS} pin can be read via the SPR0 bit.															

¹ The CPOL and CPHA bits should both contain the same values for master and slave devices.

SPIDAT (SPI Data Register)

SFR Address: F7H
 Power-On Default Value: 00H
 Bit Addressable: No

The SPIDAT SFR is written by the user to transmit data over the SPI interface, or read by the user read data just received by the SPI interface.

USING THE SPI INTERFACE

Depending on the configuration of the bits in the SPICON SFR shown in Table 28, the ADuC832 SPI interface transmits or receives data in a number of possible modes. Figure 63 shows all possible ADuC832 SPI configurations and the timing relationships and synchronization between the signals involved. Also shown is the SPI interrupt bit (ISPI) and how it is triggered at the end of each byte-wide communication.

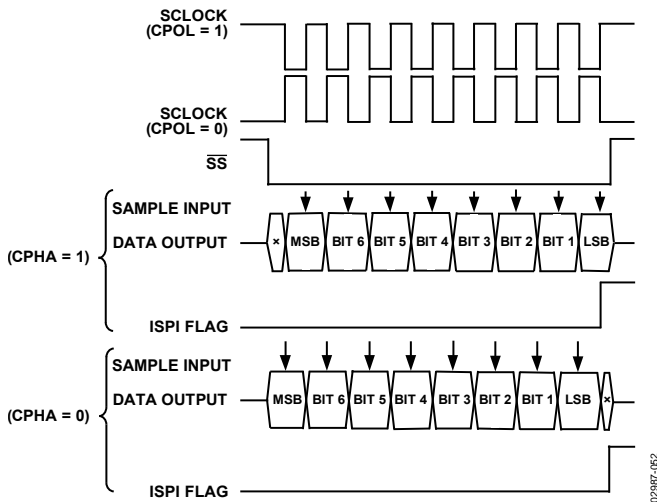

Figure 63. SPI Timing, All Modes

SPI INTERFACE—MASTER MODE

In master mode, the SCLOCK pin is always an output and generates a burst of eight clocks whenever user code writes to the SPIDAT register. The SCLOCK bit rate is determined by $\overline{SPR0}$ and $\overline{SPR1}$ in SPICON. It should also be noted that the \overline{SS} pin is not used in master mode. If the ADuC832 needs to assert the \overline{SS} pin on an external slave device, a port digital output pin should be used.

In master mode, a byte transmission or reception is initiated by a write to SPIDAT. Eight clock periods are generated via the SCLOCK pin and the SPIDAT byte being transmitted via MOSI. With each SCLOCK period, a data bit is also sampled via MISO. After eight clocks, the transmitted byte is completely transmitted and the input byte waits in the input shift register. The ISPI flag is set automatically and an interrupt occurs if enabled. The value in the shift register is latched into SPIDAT.

SPI INTERFACE—SLAVE MODE

In slave mode, the SCLOCK is an input. The \overline{SS} pin must also be driven low externally during the byte communication.

Transmission is also initiated by a write to SPIDAT. In slave mode, a data bit is transmitted via MISO and a data bit is received via MOSI through each input SCLOCK period. After eight clocks, the transmitted byte is completely transmitted and the input byte waits in the input shift register. The ISPI flag is set automatically and an interrupt occurs if enabled. The value in the shift register is latched into SPIDAT only when the transmission/reception of a byte has been completed. The end of transmission occurs after the eighth clock has been received if CPHA = 1, or when \overline{SS} returns high if CPHA = 0.

I²C-COMPATIBLE INTERFACE

The ADuC832 supports a fully licensed I²C serial interface. The I²C interface is implemented as a full hardware slave and software master. SDATA is the data I/O pin and SCLOCK is the serial clock. These two pins are shared with the MOSI and SCLOCK pins of the on-chip SPI interface. Therefore, the user can only enable one interface or the other at any given time (see SPE in SPICON in Table 28). The uC001 Technical Note, *MicroConverter® I²C® Compatible Interface*, describes the operation of this interface as implemented.

I²C INTERFACE SFRs

Three SFRs are used to control the I²C interface. These are described in the following sections.

I2CCON (I²C Control Register)

SFR Address: E8H
 Power-On Default Value: 00H
 Bit Addressable: Yes

I2CADD (I²C Address Register)

SFR Address: 9BH
 Power-On Default Value: 55H
 Bit Addressable: No

The I2CADD SFR holds the I²C peripheral address for the part. It can be overwritten by user code. Technical Note uC001 describes the format of the I²C standard 7-bit address in detail.

I2CDAT (I²C Data Register)

SFR Address: 9AH
 Power-On Default Value: 00H
 Bit Addressable: No

The I2CDAT SFR is written by the user to transmit data over the I²C interface or read by user code to read data just received by the I²C interface. Accessing I2CDAT automatically clears any pending I²C interrupt and the I2CI bit in the I2CCON SFR. User software should only access I2CDAT once per interrupt cycle.

Table 29. I2CCON SFR Bit Designations

Bit	Name	Description
[7]	MDO	I ² C software master data output bit (master mode only). This data bit is used to implement a master I ² C transmitter interface in software. Data written to this bit is output on the SDATA pin if the data output enable (MDE) bit is set.
[6]	MDE	I ² C software master data output enable bit (master mode only). Set by user to enable the SDATA pin as an output (Tx). Cleared by the user to enable SDATA pin as an input (Rx).
[5]	MCO	I ² C software master clock output bit (master mode only). This data bit is used to implement a master I ² C transmitter interface in software. Data written to this bit is output on the SCLOCK pin.
[4]	MDI	I ² C software master data input bit (master mode only). This data bit is used to implement a master I ² C receiver interface in software. Data on the SDATA pin is latched into this bit on SCLOCK if the data output enable (MDE) bit is 0.
[3]	I2CM	I ² C master/slave mode bit set by user to enable I ² C software master mode. Cleared by user to enable I ² C hardware slave mode.
[2]	I2CRS	I ² C reset bit (slave mode only). Set by user to reset the I ² C interface. Cleared by user code for normal I ² C operation.
[1]	I2CTX	I ² C direction transfer bit (slave mode only). Set by the MicroConverter if the interface is transmitting. Cleared by the MicroConverter if the interface is receiving.
[0]	I2CI	I ² C interrupt bit (slave mode only). Set by the MicroConverter after a byte has been transmitted or received. Cleared automatically when user code reads the I2CDAT SFR (see the I2CADD (I ² C Address Register) section).

OVERVIEW

The main features of the MicroConverter I²C interface are:

- Only two bus lines are required; a serial data line (SDATA) and a serial clock line (SCLOCK).
- An I²C master can communicate with multiple slave devices. Because each slave device has a unique 7-bit address, single master/slave relationships can exist at all times even in a multislave environment (Figure 64).
- On-chip filtering rejects <50 ns spikes on the SDATA and the SCLOCK lines to preserve data integrity.



Figure 64. Typical I²C System

SOFTWARE MASTER MODE

The ADuC832 can be used as an I²C master device by configuring the I²C peripheral in master mode and writing software to output the data bit by bit. This is referred to as a software master. Master mode is enabled by setting the I2CM bit in the I2CCON register.

To transmit data on the SDATA line, MDE must be set to enable the output driver on the SDATA pin. If MDE is set, then the SDATA pin is pulled high or low depending on whether the MDO bit is set or cleared. MCO controls the SCLOCK pin and is always configured as an output in master mode. In master mode, the SCLOCK pin is pulled high or low depending on the whether MCO is set or cleared.

To receive data, MDE must be cleared to disable the output driver on SDATA. Software must provide the clocks by toggling the MCO bit and reading the SDATA pin via the MDI bit. If MDE is cleared, MDI can be used to read the SDATA pin. The value of the SDATA pin is latched into MDI on a rising edge of SCLOCK. MDI is set if the SDATA pin was high on the last rising edge of SCLOCK. MDI is cleared if the SDATA pin was low on the last rising edge of SCLOCK.

Software must control MDO, MCO, and MDE appropriately to generate the start condition, slave address, acknowledge bits, data bytes, and stop conditions appropriately. These functions are provided in Technical Note uC001.

HARDWARE SLAVE MODE

After reset, the ADuC832 defaults to hardware slave mode. The I²C interface is enabled by clearing the SPE bit in SPICON. Slave mode is enabled by clearing the I2CM bit in I2CCON. The ADuC832 has a full hardware slave. In slave mode, the I²C address is stored in the I2CADD register. Data received or to be transmitted is stored in the I2CDAT register.

Once enabled in I²C slave mode, the slave controller waits for a start condition. If the ADuC832 detects a valid start condition, followed by a valid address, followed by the R/W bit, the I2CI interrupt bit is automatically set by hardware.

The I²C peripheral only generates a core interrupt if the user has preconfigured the I²C interrupt enable bit (ESI) in the IEIP2 SFR, as well as the global interrupt bit (EA) in the IE SFR.

```
; Enabling I2C Interrupts for the ADuC832
MOV IEIP2,#01H      ; enable I2C interrupt
SETB EA
```

On the ADuC832, an autoclear of the I2CI bit is implemented so this bit is cleared automatically on a read or write access to the I2CDAT SFR.

```
MOV I2CDAT, A      ; I2CI autocleared
MOV A, I2CDAT      ; I2CI autocleared
```

If for any reason the user tries to clear the interrupt more than once, that is, access the data SFR more than once per interrupt, then the I²C controller stops. The interface then must be reset using the I2CRS bit.

The user can choose to poll the I2CI bit or enable the interrupt. In the case of the interrupt, the PC counter vectors to 003BH at the end of each complete byte. For the first byte, when the user reaches the I2CI interrupt service routine (ISR), the 7-bit address and the R/W bit appear in the I2CDAT SFR.

The I2CTX bit contains the R/W bit sent from the master. If I2CTX is set, then the master waits to receive a byte. Thus the slave transmits data by writing to the I2CDAT register. If I2CTX is cleared, the master transmits a byte. Therefore, the slave receives a serial byte. The software can check the state of I2CTX to determine whether it should write to or read from I2CDAT.

Once the ADuC832 has received a valid address, the hardware hold SCLOCK low until the I2CI bit is cleared by software. This allows the master to wait for the slave to be ready before transmitting the clocks for the next byte.

The I2CI interrupt bit is set every time a complete data byte is received or transmitted, provided it is followed by a valid ACK. If the byte is followed by a NACK, an interrupt is not generated. The ADuC832 continues to issue interrupts for each complete data byte transferred until a stop condition is received or the interface is reset.

When a stop condition is received, the interface resets to a state where it is waiting to be addressed (idle). Similarly, if the interface receives a NACK at the end of a sequence, it also returns to the default idle state. The I2CRS bit can be used to reset the I²C interface. This bit can be used to force the interface back to the default idle state.

It should be noted that there is no way (in hardware) to distinguish between an interrupt generated by a received start plus valid address and an interrupt generated by a received data byte. User software must be used to distinguish between these interrupts.

DUAL DATA POINTERS

The ADuC832 incorporates two data pointers. The second data pointer is a shadow data pointer and is selected via the data pointer control SFR (DPCON). DPCON also includes features such as automatic hardware postincrement and postdecrement, as well as automatic data pointer toggle. DPCON is described in Table 30.

DPCON (DATA POINTER CONTROL SFR)

SFR Address: A7H
 Power-On Default Value: 00H
 Bit Addressable: No

Table 30. DPCON SFR Bit Designations

Bit	Name	Description															
[7]	Reserved	Reserved for future use.															
[6]	DPT	Data pointer automatic toggle enable. Cleared by user to disable auto swapping of the DPTR. Set in user software to enable automatic toggling of the DPTR after each MOVX or MOVC instruction.															
[5:4]	DP1m[1:0]	Shadow data pointer mode. These two bits enable extra modes of the shadow data pointer operation, allowing for more compact and more efficient code size and execution.															
		<table border="1"> <thead> <tr> <th>DP1m1</th> <th>DP1m0</th> <th>Behavior of Shadow Data Pointer</th> </tr> </thead> <tbody> <tr> <td>0</td> <td>0</td> <td>8052 behavior</td> </tr> <tr> <td>0</td> <td>1</td> <td>DPTR is postincremented after a MOVX or a MOVC instruction.</td> </tr> <tr> <td>1</td> <td>0</td> <td>DPTR is postdecremented after a MOVX or MOVC instruction.</td> </tr> <tr> <td>1</td> <td>1</td> <td>DPTR LSB is toggled after a MOVX or MOVC instruction. (This instruction can be useful for moving 8-bit blocks to/from 16-bit devices.)</td> </tr> </tbody> </table>	DP1m1	DP1m0	Behavior of Shadow Data Pointer	0	0	8052 behavior	0	1	DPTR is postincremented after a MOVX or a MOVC instruction.	1	0	DPTR is postdecremented after a MOVX or MOVC instruction.	1	1	DPTR LSB is toggled after a MOVX or MOVC instruction. (This instruction can be useful for moving 8-bit blocks to/from 16-bit devices.)
DP1m1	DP1m0	Behavior of Shadow Data Pointer															
0	0	8052 behavior															
0	1	DPTR is postincremented after a MOVX or a MOVC instruction.															
1	0	DPTR is postdecremented after a MOVX or MOVC instruction.															
1	1	DPTR LSB is toggled after a MOVX or MOVC instruction. (This instruction can be useful for moving 8-bit blocks to/from 16-bit devices.)															
[3:2]	DP0m[1:0]	Main data pointer mode. These two bits enable extra modes of the main data pointer operation, allowing for more compact and more efficient code size and execution.															
		<table border="1"> <thead> <tr> <th>DP0m1</th> <th>DP0m0</th> <th>Behavior of the Main Data Pointer</th> </tr> </thead> <tbody> <tr> <td>0</td> <td>0</td> <td>8052 behavior</td> </tr> <tr> <td>0</td> <td>1</td> <td>1 DPTR is postincremented after a MOVX or a MOVC instruction.</td> </tr> <tr> <td>1</td> <td>0</td> <td>DPTR is postdecremented after a MOVX or MOVC instruction.</td> </tr> <tr> <td>1</td> <td>1</td> <td>DPTR LSB is toggled after a MOVX or MOVC instruction. (This instruction can be useful for moving 8-bit blocks to/from 16-bit devices.)</td> </tr> </tbody> </table>	DP0m1	DP0m0	Behavior of the Main Data Pointer	0	0	8052 behavior	0	1	1 DPTR is postincremented after a MOVX or a MOVC instruction.	1	0	DPTR is postdecremented after a MOVX or MOVC instruction.	1	1	DPTR LSB is toggled after a MOVX or MOVC instruction. (This instruction can be useful for moving 8-bit blocks to/from 16-bit devices.)
DP0m1	DP0m0	Behavior of the Main Data Pointer															
0	0	8052 behavior															
0	1	1 DPTR is postincremented after a MOVX or a MOVC instruction.															
1	0	DPTR is postdecremented after a MOVX or MOVC instruction.															
1	1	DPTR LSB is toggled after a MOVX or MOVC instruction. (This instruction can be useful for moving 8-bit blocks to/from 16-bit devices.)															
[1]	Reserved	This bit is not implemented to allow the INC DPCON instruction to toggle the data pointer without incrementing the rest of the SFR.															
[0]	DPSEL	Data pointer select. Cleared by user to select the main data pointer. This means that the contents of this 24-bit register are placed into the DPL, DPH, and DPP SFRs. Set by the user to select the shadow data pointer. This means that the contents of a separate 24-bit register appears in the DPL, DPH, and DPP SFRs.															

Notes

This is the only section where the main and shadow data pointers are distinguished. Everywhere else in this data sheet wherever the DPTR is mentioned, operation on the active DPTR is implied.

Only MOVX/MOVC @DPTR instructions are relevant in Table 30. MOVX/MOVC PC/@Ri instructions do not cause the DPTR to automatically postincrement or postdecrement.

To illustrate the operation of DPCON, the following code copies 256 bytes of code memory at Address D000H into XRAM starting from Address 0000H.

The following code uses 16 bytes and 2054 cycles. To perform this on a standard 8051 requires approximately 33 bytes and 7172 cycles (depending on how it is implemented).

```

MOV DPTR,#0 ; Main DPTR = 0
MOV DPCON,#55H ; Select shadow DPTR
; DPTR1 increment mode,
; DPTR0 increment mode
; DPTR auto toggling on
MOV DPTR,#0D000H ; Shadow DPTR = D000H
MOVELOOP:
CLR A
MOVC A,@A+DPTR ; Get data
; Post Inc DPTR
; Swap to Main DPTR (Data)
MOVX @DPTR,A ; Put ACC in XRAM
; Increment main DPTR
; Swap Shadow DPTR (Code)

MOV A, DPL
JNZ MOVELOOP

```

POWER SUPPLY MONITOR

As its name suggests, the power supply monitor, once enabled, monitors the DV_{DD} supply on the ADuC832. It indicates when any of the supply pins drop below one of four user-selectable voltage trip points from 2.63 V to 4.37 V. For correct operation of the power supply monitor function, AV_{DD} must be equal to or greater than 2.7 V. The monitor function is controlled via the PSMCON SFR. If enabled via the IEIP2 SFR, the monitor interrupts the core using the PSMI bit in the PSMCON SFR. This bit is not cleared until the failing power supply has returned above the trip point for at least 250 ms. This monitor function allows the user to save working registers to avoid possible data loss due to the low supply condition, and ensures that normal

code execution does not resume until a safe supply level has been well established. The supply monitor is also protected against spurious glitches triggering the interrupt circuit.

PSMCON (POWER SUPPLY MONITOR CONTROL REGISTER)

SFR Address: DFH

Power-On Default Value: DEH

Bit Addressable : No

Table 31. PSMCON SFR Bit Designations

Bit	Name	Description															
[7]	Reserved	Reserved.															
[6]	CMPD	DV _{DD} comparator bit. This is a read-only bit and directly reflects the state of the DV _{DD} comparator. Read 1 indicates the DV _{DD} supply is above its selected trip point. Read 0 indicates the DV _{DD} supply is below its selected trip point.															
[5]	PSMI	Power supply monitor interrupt bit. This bit is set high by the MicroConverter if CMPD is low, indicating low analog or digital supply. The PSMI bit can be used to interrupt the processor. Once CMPD returns (and remains) high, a 250 ms counter is started. When this counter times out, the PSMI interrupt is cleared. PSMI can also be written by the user. However, if either comparator output is low, it is not possible for the user to clear PSMI.															
[4:3]	TPD[1:0]	DV _{DD} trip point selection bits. These bits select the DV _{DD} trip point voltage as follows:															
		<table border="1"> <thead> <tr> <th>TPD1</th> <th>TPD0</th> <th>Selected DV_{DD} Trip Point (V)</th> </tr> </thead> <tbody> <tr> <td>0</td> <td>0</td> <td>4.37</td> </tr> <tr> <td>0</td> <td>1</td> <td>3.08</td> </tr> <tr> <td>1</td> <td>0</td> <td>2.93</td> </tr> <tr> <td>1</td> <td>1</td> <td>2.63</td> </tr> </tbody> </table>	TPD1	TPD0	Selected DV _{DD} Trip Point (V)	0	0	4.37	0	1	3.08	1	0	2.93	1	1	2.63
TPD1	TPD0	Selected DV _{DD} Trip Point (V)															
0	0	4.37															
0	1	3.08															
1	0	2.93															
1	1	2.63															
[2]	Reserved	Reserved.															
[1]	Reserved	Reserved.															
[0]	PSMEN	Power supply monitor enable bit. Set to 1 by the user to enable the power supply monitor circuit. Cleared to 0 by the user to disable the power supply monitor circuit.															

WATCHDOG TIMER

The purpose of the watchdog timer is to generate a device reset or interrupt within a reasonable amount of time if the ADuC832 enters an erroneous state, possibly due to a programming error or electrical noise. The watchdog function can be disabled by clearing the watchdog enable (WDE) bit in the watchdog control (WDCON) SFR. When enabled, the watchdog circuit generates a system reset or interrupt (WDS) if the user program fails to set the watchdog (WDE) bit within a predetermined amount of time (see the PRE[3:0] bits in WDCON). The watchdog timer itself is a 16-bit counter that is clocked directly from the 32.768 kHz external crystal. The watchdog timeout interval can be adjusted via the PRE[3:0] bits in WDCON. Full control and status of the watchdog timer function can be con-

trolled via the watchdog timer control SFR (WDCON). The WDCON SFR can only be written by user software if the double write sequence described in the WDWR description (see Table 32) is initiated on every write access to the WDCON SFR.

WDCON (Watchdog Timer Control Register)

SFR Address:	C0H
Power-On Default Value:	10H
Bit Addressable:	Yes

Table 32. WDCON SFR Bit Designations

Bit	Name	Description																																																												
[7:4]	PRE[3:0]	Watchdog timer prescale bits. The watchdog timeout period is given by the following equation: $t_{WD} = (2^{PRE} \times (2^9 / f_{XTAL})).$ where $0 \leq PRE \leq 7$ and $f_{XTAL} = 32.768$ kHz.																																																												
		<table border="1"> <thead> <tr> <th>PRE3</th> <th>PRE2</th> <th>PRE1</th> <th>PRE0</th> <th>Timeout Period (ms)</th> <th>Action</th> </tr> </thead> <tbody> <tr> <td>0</td> <td>0</td> <td>0</td> <td>0</td> <td>15.6</td> <td>Reset or Interrupt</td> </tr> <tr> <td>0</td> <td>0</td> <td>0</td> <td>1</td> <td>31.2</td> <td>Reset or Interrupt</td> </tr> <tr> <td>0</td> <td>0</td> <td>1</td> <td>0</td> <td>62.5</td> <td>Reset or Interrupt</td> </tr> <tr> <td>0</td> <td>0</td> <td>1</td> <td>1</td> <td>125</td> <td>Reset or Interrupt</td> </tr> <tr> <td>0</td> <td>1</td> <td>0</td> <td>0</td> <td>250</td> <td>Reset or Interrupt</td> </tr> <tr> <td>0</td> <td>1</td> <td>0</td> <td>1</td> <td>500</td> <td>Reset or Interrupt</td> </tr> <tr> <td>0</td> <td>1</td> <td>1</td> <td>0</td> <td>1000</td> <td>Reset or Interrupt</td> </tr> <tr> <td>0</td> <td>1</td> <td>1</td> <td>1</td> <td>2000</td> <td>Reset or Interrupt</td> </tr> <tr> <td>1</td> <td>0</td> <td>0</td> <td>0</td> <td>0.0</td> <td>Immediate Reset</td> </tr> </tbody> </table> PRE[3:0] > 1000 = reserved.	PRE3	PRE2	PRE1	PRE0	Timeout Period (ms)	Action	0	0	0	0	15.6	Reset or Interrupt	0	0	0	1	31.2	Reset or Interrupt	0	0	1	0	62.5	Reset or Interrupt	0	0	1	1	125	Reset or Interrupt	0	1	0	0	250	Reset or Interrupt	0	1	0	1	500	Reset or Interrupt	0	1	1	0	1000	Reset or Interrupt	0	1	1	1	2000	Reset or Interrupt	1	0	0	0	0.0	Immediate Reset
PRE3	PRE2	PRE1	PRE0	Timeout Period (ms)	Action																																																									
0	0	0	0	15.6	Reset or Interrupt																																																									
0	0	0	1	31.2	Reset or Interrupt																																																									
0	0	1	0	62.5	Reset or Interrupt																																																									
0	0	1	1	125	Reset or Interrupt																																																									
0	1	0	0	250	Reset or Interrupt																																																									
0	1	0	1	500	Reset or Interrupt																																																									
0	1	1	0	1000	Reset or Interrupt																																																									
0	1	1	1	2000	Reset or Interrupt																																																									
1	0	0	0	0.0	Immediate Reset																																																									
[3]	WDIR	Watchdog interrupt response enable bit. If this bit is set by the user, the watchdog generates an interrupt response instead of a system reset when the watchdog timeout period has expired. This interrupt is not disabled by the CLR EA instruction and it is also a fixed, high priority interrupt. If the watchdog is not being used to monitor the system, it can alternatively be used as a timer. The prescaler is used to set the timeout period in which an interrupt is generated.																																																												
[2]	WDS	Watchdog status bit. Set by the watchdog controller to indicate that a watchdog timeout has occurred. Cleared by writing a 0 or by an external hardware reset. It is not cleared by a watchdog reset.																																																												
[1]	WDE	Watchdog enable bit. Set by user to enable the watchdog and clear its counters. If this bit is not set by the user within the watchdog timeout period, the watchdog generates a reset or interrupt, depending on WDIR. Cleared under the following conditions: user writes 0, watchdog reset (WDIR = 0), hardware reset, or PSM interrupt.																																																												
[0]	WDWR	Watchdog write enable bit. To write data into the WDCON SFR involves a double instruction sequence. The WDWR bit must be set and the very next instruction must be a write instruction to the WDCON SFR. See the Example Write Instruction section.																																																												

Example Write Instruction

```

CLR      EA                ;disable interrupts while writing
                          ;to WDT
SETB    WDWR              ;allow write to WDCON
MOV     WDCON,            #72H    ;enable WDT for 2.0 sec timeout
SETB    EA                ;enable interrupts again (if reqd)
  
```

TIME INTERVAL COUNTER (TIC)

A time interval counter is provided on chip for counting longer intervals than the standard 8051-compatible timers are capable of. The TIC is capable of timeout intervals ranging from 1/128 second to 255 hours. Furthermore, this counter is clocked by the external 32.768 kHz crystal rather than the core clock, and has the ability to remain active in power-down mode and time long power-down intervals. This has obvious applications for remote battery-powered sensors where regular widely spaced readings are required. Note that instructions to the TIC SFRs are also clocked at 32.768 kHz, and sufficient time must be allowed in user code for these instructions to execute.

Six SFRs are associated with the time interval counter, TIMECON being its control register. Depending on the configuration of the ITS0 and ITS1 bits in TIMECON, the selected time counter register overflow clocks the interval counter. When this counter is equal to the time interval value loaded in the INTVAL SFR, the TII bit (TIMECON[2]) is set and generates an interrupt if enabled. If the ADuC832 is in power-down mode, again with the TIC interrupt enabled, the TII bit wakes up the device and resumes code execution by vectoring directly to the TIC interrupt service vector address at 0053H. The TIC-related SFRs are described in the following sections. Note also that the timebase SFRs can be written initially with the current time; the TIC can then be controlled and accessed by user software. In effect, this facilitates the implementation of a real-time clock. A block diagram of the TIC is shown in Figure 65.



Figure 65. TIC, Simplified Block Diagram

TIMECON (TIC CONTROL REGISTER)

SFR Address: A1H
 Power-On Default Value: 00H
 Bit Addressable: No

Table 33. TIMECON SFR Bit Designations

Bit	Name	Description															
[7]	Reserved	Reserved for future use.															
[6]	TFH	Twenty-four hour select bit. Set by the user to enable the hour counter to count from 0 to 23. Cleared by the user to enable the hour counter to count from 0 to 255.															
[5:4]	ITS[1:0]	Interval timebase selection bits. Written by user to determine the interval counter update rate. <table border="1" style="width: 100%; margin-top: 5px;"> <thead> <tr> <th>ITS1</th> <th>ITS0</th> <th>Interval Timebase</th> </tr> </thead> <tbody> <tr> <td>0</td> <td>0</td> <td>1/128 second</td> </tr> <tr> <td>0</td> <td>1</td> <td>Seconds</td> </tr> <tr> <td>1</td> <td>0</td> <td>Minutes</td> </tr> <tr> <td>1</td> <td>1</td> <td>Hours</td> </tr> </tbody> </table>	ITS1	ITS0	Interval Timebase	0	0	1/128 second	0	1	Seconds	1	0	Minutes	1	1	Hours
ITS1	ITS0	Interval Timebase															
0	0	1/128 second															
0	1	Seconds															
1	0	Minutes															
1	1	Hours															
[3]	STI	Single-time interval bit. Set by the user to generate a single interval timeout. If set, a timeout clears the TIEN bit. Cleared by the user to allow the interval counter to be automatically reloaded and starts counting again at each interval timeout.															
[2]	TII	TIC interrupt bit. Set when the 8-bit interval counter matches the value in the INTVAL SFR. Cleared by user software.															
[1]	TIEN	Time interval enable bit. Set by the user to enable the 8-bit time interval counter. Cleared by the user to disable the interval counter.															
[0]	TCEN	Time clock enable bit. Set by the user to enable the time clock to the time interval counters. Cleared by the user to disable the clock to the time interval counters and to reset the time interval SFRs to the last value written to them by the user. The time registers (HTHSEC, SEC, MIN, and hour) can be written while TCEN is low.															

INTVAL (USER TIME INTERVAL SELECT REGISTER)

SFR Address: A6H
 Power-On Default Value: 00H
 Bit Addressable: No
 Valid Value: 0 to 255 decimal

User code writes the required time interval to this register. When the 8-bit interval counter is equal to the time interval value loaded in the INTVAL SFR, the TII bit (TIMECON[2]) is set and generates an interrupt if enabled.

HTHSEC (HUNDREDTHS SECONDS TIME REGISTER)

SFR Address: A2H
 Power-On Default Value: 00H
 Bit Addressable: No
 Valid Value: 0 to 127 decimal

This register is incremented in 1/128 second intervals when TCEN in TIMECON is active. The HTHSEC SFR counts from 0 to 127 before rolling over to increment the SEC time register.

SEC (SECONDS TIME REGISTER)

SFR Address: A3H
 Power-On Default Value: 00H
 Bit Addressable: No
 Valid Value: 0 to 59 decimal

This register is incremented in 1 second intervals when TCEN in TIMECON is active. The SEC SFR counts from 0 to 59 before rolling over to increment the MIN time register.

MIN (MINUTES TIME REGISTER)

SFR Address: A4H
 Power-On Default Value: 00H
 Bit Addressable: No
 Valid Value: 0 to 59 decimal

This register is incremented in 1 minute intervals when TCEN in TIMECON is active. The MIN counts from 0 to 59 before rolling over to increment the hour time register.

HOUR (HOURS TIME REGISTER)

SFR Address: A5H
 Power-On Default Value: 00H
 Bit Addressable: No
 Valid Value: 0 to 23 decimal

This register is incremented in 1 hour intervals when TCEN in TIMECON is active. The hour SFR counts from 0 to 23 before rolling over to 0.

8052-COMPATIBLE ON-CHIP PERIPHERALS

This section gives a brief overview of the various secondary peripheral circuits that are also available to the user on chip. These remaining functions are mostly 8052 compatible (with a few additional features) and are controlled via standard 8052 SFR bit definitions.

PARALLEL I/O

The ADuC832 uses four input/output ports to exchange data with external devices. In addition to performing general-purpose I/O, some ports are capable of external memory operations whereas others are multiplexed with alternate functions for the peripheral features on the device. In general, when a peripheral is enabled, that pin cannot be used as a general-purpose I/O pin.

PORT 0

Port 0 is an 8-bit, open-drain, bidirectional I/O port that is directly controlled via the Port 0 SFR. Port 0 is also the multiplexed low order address and data bus during accesses to external program or data memory.

Figure 66 shows a typical bit latch and I/O buffer for a Port 0 port pin. The bit latch (one bit in the port's SFR) is represented as a Type D flip-flop, which clocks in a value from the internal bus in response to a write-to-latch signal from the CPU. The Q output of the flip-flop is placed on the internal bus in response to a read latch signal from the CPU. The level of the port pin itself is placed on the internal bus in response to a read pin signal from the CPU. Some instructions that read a port activate the read latch signal, and others activate the read pin signal. See the Read-Modify-Write Instructions section for more details.

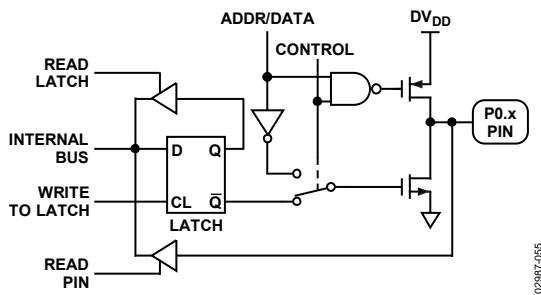

Figure 66. Port 0 Bit Latch and I/O Buffer

As shown in Figure 66, the output drivers of Port 0 pins are switchable to an internal ADDR and ADDR/data bus by an internal control signal for use in external memory accesses. During external memory accesses, 1s are written to the P0 SFR (that is, all of its bit latches become 1). When accessing external memory, the control signal in Figure 66 goes high, enabling push-pull operation of the output pin from the internal address or data bus (ADDR/data line). Therefore, no external pull-ups are required on Port 0 for it to access external memory.

In general-purpose I/O port mode, Port 0 pins that have 1s written to them via the Port 0 SFR are configured as open drain and therefore float. In this state, Port 0 pins can be used as high impedance inputs. This is represented in Figure 66 by the

NAND gate whose output remains high as long as the control signal is low, thereby disabling the top FET. External pull-up resistors are therefore required when Port 0 pins are used as general-purpose outputs. Port 0 pins with 0s written to them drive a logic low output voltage (V_{OL}) and are capable of sinking 1.6 mA.

PORT 1

Port 1 is also an 8-bit port directly controlled via the P1 SFR.

Port 1 digital output capability is not supported on this device.

Port 1 pins can be configured as digital inputs or analog inputs.

By (power-on) default, these pins are configured as analog inputs, that is, 1 written in the corresponding Port 1 register bit. To configure any of these pins as digital inputs, write a 0 to these port bits to configure the corresponding pin as a high impedance digital input.

These pins also have various secondary functions described in Table 34.

Table 34. Port 1, Alternate Pin Functions

Pin	Alternate Function
P1.0	T2 (Timer/Counter 2 external input) or ADC0 (single-ended analog input)
P1.1	T2EX (Timer/Counter 2 capture/reload trigger) or ADC1
P1.5	\overline{SS} (slave select for the SPI interface) or ADC5

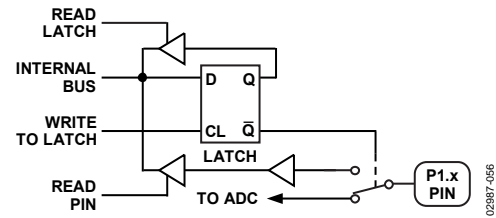

Figure 67. Port 1 Bit Latch and I/O Buffer

PORT 2

Port 2 is a bidirectional port with internal pull-up resistors directly controlled via the P2 SFR. Port 2 also emits the high order address bytes during fetches from external program memory and middle and high order address bytes during accesses to the 24-bit external data memory space.

As shown in Figure 68, the output drivers of Port 2 are switchable to an internal ADDR and ADDR/data bus by an internal control signal for use in external memory accesses (as for Port 0). In external memory addressing mode (control = 1), the port pins feature push-pull operation controlled by the internal address bus (ADDR line). However, unlike the P0 SFR during external memory accesses, the P2 SFR remains unchanged.

In general-purpose I/O port mode, Port 2 pins that have 1s written to them are pulled high by the internal pull-ups (see Figure 69) and, in that state, can be used as inputs. As inputs, Port 2 pins pulled externally low source current because of the internal pull-up resistors. Port 2 pins with 0s written to

them drive a logic low output voltage (V_{OL}) and are capable of sinking 1.6 mA.

P2.6 and P2.7 can also be used as PWM outputs. If they are selected as the PWM outputs via the CFG832 SFR, the PWM outputs overwrite anything written to P2.6 or P2.7.



Figure 68. Port 2 Bit Latch and I/O Buffer

02987-057



Figure 69. Internal Pull-Up Configuration

02987-058

PORT 3

Port 3 is a bidirectional port with internal pull-ups directly controlled via the P3 SFR. Port 3 pins that have 1s written to them are pulled high by the internal pull-ups and, in that state, can be used as inputs. As inputs, Port 3 pins pulled externally low source current because of the internal pull-ups. Port 3 pins with 0s written to them drive a logic low output voltage (V_{OL}) and are capable of sinking 4 mA.

Port 3 pins also have various secondary functions described in Table 35. The alternate functions of Port 3 pins can only be activated if the corresponding bit latch in the P3 SFR contains a 1. Otherwise, the port pin is stuck at 0.

Table 35. Port 3, Alternate Pin Functions

Pin	Alternate Function
P3.0	RxD (UART input pin or serial data I/O in Mode 0)
P3.1	TxD (UART output pin or serial clock output in Mode 0)
P3.2	$\overline{INT0}$ (External Interrupt 0)
P3.3	$\overline{INT1}$ (External Interrupt 1) or PWM1/MISO
P3.4	T0 (Timer/Counter 0 external input), PWMC, PWM0, or EXTCLK
P3.5	T1 (Timer/Counter 1 external input) or \overline{CONVST}
P3.6	\overline{WR} (external data memory write strobe)
P3.7	\overline{RD} (external data memory read strobe)

P3.3 and P3.4 can also be used as PWM outputs. If they are selected as the PWM outputs via the CFG832 SFR, the PWM outputs overwrite anything written to P3.4 or P3.3.



Figure 70. Port 3 Bit Latch and I/O Buffer

02987-059

ADDITIONAL DIGITAL I/O

In addition to the port pins, the dedicated SPI/I²C pins (SCLOCK and SDATA/MOSI) also feature both input and output functions. Their equivalent I/O architectures are illustrated in Figure 71 and Figure 73, respectively, for SPI operation and in Figure 72 and Figure 74 for I²C operation.

Notice that in I²C mode (SPE, SPICON[5] = 0), the strong pull-up FET (Q1) is disabled, leaving only a weak pull-up (Q2) present. By contrast, in SPI mode (SPE = 1) the strong pull-up FET (Q1) is controlled directly by SPI hardware, giving the pin push-pull capability.

In I²C mode (SPE = 0), two pull-down FETs (Q3 and Q4) operate in parallel to provide an extra 60% or 70% of current sinking capability. In SPI mode, however, (SPE = 1) only one of the pull-down FETs (Q3) operates on each pin, resulting in sink capabilities identical to that of Port 0 and Port 2 pins. On the input path of SCLOCK, notice that a Schmitt trigger conditions the signal going to the SPI hardware to prevent false triggers (double triggers) on slow incoming edges. For incoming signals from the SCLOCK and SDATA pins going to I²C hardware, a filter conditions the signals in order to reject glitches of up to 50 ns in duration.

Notice also that direct access to the SCLOCK and SDATA/MOSI pins is afforded through the SFR interface in I²C master mode. Therefore, if the SPI or I²C functions are not used, these two pins can be used to give additional high current digital outputs.

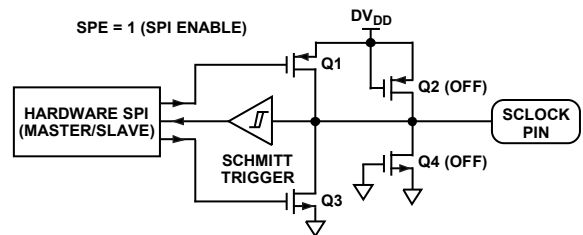

Figure 71. SCLOCK Pin I/O Functional Equivalent in SPI Mode

02987-060



Figure 72. SCLOCK Pin I/O Functional Equivalent in I²C Mode



Figure 73. SDATA/MOSI Pin I/O Functional Equivalent in SPI Mode

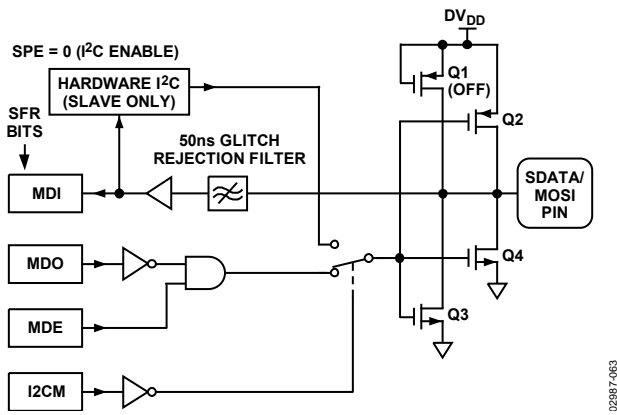

Figure 74. SDATA/MOSI Pin I/O Functional Equivalent in I²C Mode

MISO is shared with P3.3 and as such has the same configuration as that shown in Figure 70.

READ-MODIFY-WRITE INSTRUCTIONS

Some 8051 instructions that read a port read the latch while others read the pin. The instructions that read the latch rather than the pins are the ones that read a value, possibly change it, and then rewrite it to the latch. These are called read-modify-write instructions. Listed below are the read-modify-write instructions. When the destination operand is a port, or a port bit, these instructions read the latch rather than the pin.

Instruction	Description
ANL	Logical AND, for example, ANL P1, A
ORL	Logical OR, for example, ORL P2, A
XRL	Logical EX-OR, for example, XRL P3, A
JBC	Jump if bit = 1 and clear bit, for example, JBC P1.1, LABEL
CPL	Complement bit, for example, CPL P3.0
INC	Increment, for example, INC P2
DEC	Decrement, for example, DEC P2
DJNZ	Decrement and jump if not zero, for example, DJNZ P3, LABEL
MOV PX.Y, C ¹	Move carry to Bit Y of Port X
CLR PX.Y ¹	Clear Bit Y of Port X
SETB PX.Y ¹	Set Bit Y of Port X

¹ These instructions read the port byte (all 8 bits), modify the addressed bit and then write the new byte back to the latch.

The reason that read-modify-write instructions are directed to the latch rather than the pin is to avoid a possible misinterpretation of the voltage level of a pin. For example, a port pin might be used to drive the base of a transistor. When a 1 is written to the bit, the transistor is turned on. If the CPU then reads the same port bit at the pin rather than the latch, it will read the base voltage of the transistor and interpret it as a logic 0. Reading the latch rather than the pin will return the correct value of 1.

TIMERS/COUNTERS

The ADuC832 has three 16-bit timer/counters: Timer 0, Timer 1, and Timer 2. The timer/counter hardware has been included on chip to relieve the processor core of the overhead inherent in implementing timer/counter functionality in software. Each timer/counter consists of two 8-bit registers TH_x and TL_x (x = 0, 1, and 2). All three can be configured to operate either as timers or event counters.

In the timer function, the TL_x register is incremented every machine cycle. Thus, it can be thought of as counting machine cycles. Because a machine cycle consists of 12 core clock periods, the maximum count rate is 1/12 the core clock frequency.

In a counter function, the TL_x register is incremented by a 1-to-0 transition at its corresponding external input pin, T0, T1, or T2. In this function, the external input is sampled during S5P2 of every machine cycle. When the samples show a high in one cycle and a low in the next cycle, the count is incremented. The new count value appears in the register during S3P1 of the cycle following the one in which the transition was detected. Because two machine cycles (24 core clock periods) are needed to

recognize a 1-to-0 transition, the maximum count rate is 1/24 the core clock frequency. There are no restrictions on the duty cycle of the external input signal, but to ensure that a given level is sampled at least once before it changes, it must be held for a minimum of one full machine cycle.

User configuration and control of all timer operating modes is achieved via three SFRs: TMOD and TCON, which control and configure Timer 0 and Timer 1, and T2CON, which controls and configures Timer 2.

TMOD (Timer/Counter 0 and Timer/Counter 1 Mode Register)

SFR Address:	89H
Power-On Default Value:	00H
Bit Addressable:	No

Table 36. TMOD SFR Bit Designations

Bit	Name	Description															
[7]	Gate	Timer 1 gating control. Set by software to enable Timer/Counter 1 only while $\overline{\text{INT1}}$ pin is high and TR1 control bit is set. Cleared by software to enable Timer 1 whenever TR1 control bit is set.															
[6]	C/T	Timer 1 timer or counter select bit. Set by software to select counter operation (input from T1 pin). Cleared by software to select timer operation (input from internal system clock).															
[5:4]	M[1:0]	Timer 1 Mode Select Bit 1 and Bit 0. <table border="1"> <thead> <tr> <th>M1</th> <th>M0</th> <th>Description</th> </tr> </thead> <tbody> <tr> <td>0</td> <td>0</td> <td>TH1 operates as an 8-bit timer/counter. TL1 serves as a 5-bit prescaler.</td> </tr> <tr> <td>0</td> <td>1</td> <td>16-bit timer/counter. TH1 and TL1 are cascaded; there is no prescaler.</td> </tr> <tr> <td>1</td> <td>0</td> <td>8-bit autoreload timer/counter. TH1 holds a value that is to be reloaded into TL1 each time it overflows.</td> </tr> <tr> <td>1</td> <td>1</td> <td>Timer/Counter 1 stopped.</td> </tr> </tbody> </table>	M1	M0	Description	0	0	TH1 operates as an 8-bit timer/counter. TL1 serves as a 5-bit prescaler.	0	1	16-bit timer/counter. TH1 and TL1 are cascaded; there is no prescaler.	1	0	8-bit autoreload timer/counter. TH1 holds a value that is to be reloaded into TL1 each time it overflows.	1	1	Timer/Counter 1 stopped.
M1	M0	Description															
0	0	TH1 operates as an 8-bit timer/counter. TL1 serves as a 5-bit prescaler.															
0	1	16-bit timer/counter. TH1 and TL1 are cascaded; there is no prescaler.															
1	0	8-bit autoreload timer/counter. TH1 holds a value that is to be reloaded into TL1 each time it overflows.															
1	1	Timer/Counter 1 stopped.															
[3]	Gate	Timer 0 gating control. Set by software to enable Timer/Counter 0 only while $\overline{\text{INT0}}$ pin is high and TR0 control bit is set. Cleared by software to enable Timer 0 whenever TR0 control bit is set.															
[2]	C/T	Timer 0 timer or counter select bit. Set by software to select counter operation (input from T0 pin). Cleared by software to select timer operation (input from internal system clock).															
[1:0]	M[1:0]	Timer 0 Mode Select Bit 1 and Bit 0. <table border="1"> <thead> <tr> <th>M1</th> <th>M0</th> <th>Description</th> </tr> </thead> <tbody> <tr> <td>0</td> <td>0</td> <td>TH0 operates as an 8-bit timer/counter. TL0 serves as a 5-bit prescaler.</td> </tr> <tr> <td>0</td> <td>1</td> <td>16-bit timer/counter. TH0 and TL0 are cascaded; there is no prescaler.</td> </tr> <tr> <td>1</td> <td>0</td> <td>8-Bit autoreload timer/counter. TH0 holds a value that is to be reloaded into TL0 each time it overflows.</td> </tr> <tr> <td>1</td> <td>1</td> <td>TL0 is an 8-bit timer/counter controlled by the standard timer 0 control bits. TH0 is an 8-bit timer only, controlled by Timer 1 control bits.</td> </tr> </tbody> </table>	M1	M0	Description	0	0	TH0 operates as an 8-bit timer/counter. TL0 serves as a 5-bit prescaler.	0	1	16-bit timer/counter. TH0 and TL0 are cascaded; there is no prescaler.	1	0	8-Bit autoreload timer/counter. TH0 holds a value that is to be reloaded into TL0 each time it overflows.	1	1	TL0 is an 8-bit timer/counter controlled by the standard timer 0 control bits. TH0 is an 8-bit timer only, controlled by Timer 1 control bits.
M1	M0	Description															
0	0	TH0 operates as an 8-bit timer/counter. TL0 serves as a 5-bit prescaler.															
0	1	16-bit timer/counter. TH0 and TL0 are cascaded; there is no prescaler.															
1	0	8-Bit autoreload timer/counter. TH0 holds a value that is to be reloaded into TL0 each time it overflows.															
1	1	TL0 is an 8-bit timer/counter controlled by the standard timer 0 control bits. TH0 is an 8-bit timer only, controlled by Timer 1 control bits.															

TCON (Timer/Counter 0 and Timer/Counter 1 Control Register)

SFR Address:	88H
Power-On Default Value:	00H
Bit Addressable:	Yes

TIMER/COUNTER 0 AND TIMER/COUNTER 1 DATA REGISTERS

Each timer consists of two 8-bit registers. These can be used as independent registers or combined to be a single 16-bit register, depending on the timer mode configuration.

TH0 and TL0

TH0 is the Timer 0 high byte and TL0 is the low byte. The SFR addresses for TH0 and TL0 are 8CH and 8AH, respectively.

TH1 and TL1

TH1 is the Timer 1 high byte and TL1 is the low byte. The SFR addresses for TH1 and TL1 are 8DH and 8BH, respectively.

Table 37. TCON SFR Bit Designations

Bit	Name	Description
[7]	TF1	Timer 1 overflow flag. Set by hardware on a Timer/Counter 1 overflow. Cleared by hardware when the program counter (PC) vectors to the interrupt service routine.
[6]	TR1	Timer 1 run control bit. Set by the user to turn on Timer/Counter 1. Cleared by the user to turn off Timer/Counter 1.
[5]	TF0	Timer 0 overflow flag. Set by hardware on a Timer/Counter 0 overflow. Cleared by hardware when the PC vectors to the interrupt service routine.
[4]	TR0	Timer 0 run control bit. Set by the user to turn on Timer/Counter 0. Cleared by the user to turn off Timer/Counter 0.
[3]	IE1 ¹	External Interrupt 1 ($\overline{\text{INT1}}$) flag. Set by hardware by a falling edge or zero level being applied to external interrupt Pin $\overline{\text{INT1}}$, depending on the state of Bit IT1. Cleared by hardware when the PC vectors to the interrupt service routine only if the interrupt was transition-activated. If level-activated, the external requesting source controls the request flag, rather than the on-chip hardware.
[2]	IT1 ¹	External Interrupt 1 (IE1) trigger type. Set by software to specify edge-sensitive detection (that is, a 1-to-0 transition). Cleared by software to specify level-sensitive detection (that is, zero level).
[1]	IE0 ¹	External Interrupt 0 ($\overline{\text{INT0}}$) flag. Set by hardware by a falling edge or zero level being applied to external interrupt Pin $\overline{\text{INT0}}$, depending on the state of Bit IT0. Cleared by hardware when the PC vectors to the interrupt service routine only if the interrupt was transition-activated. If level-activated, the external requesting source controls the request flag, rather than the on-chip hardware.
[0]	IT0 ¹	External Interrupt 0 (IE0) trigger type. Set by software to specify edge-sensitive detection (that is, 1-to-0 transition). Cleared by software to specify level-sensitive detection (that is, zero level).

¹ These bits are not used in the control of Timer/Counter 0 and Timer/Counter 1, but are used instead in the control and monitoring of the external INT0 and INT1 interrupt pins.

TIMER/COUNTER 0 AND TIMER/COUNTER 1 OPERATING MODES

The following sections describe the operating modes for Timer/Counter 0 and Timer/Counter 1. Unless otherwise noted, it should be assumed that these modes of operation are the same for Timer 0 as for Timer 1.

MODE 0 (13-BIT TIMER/COUNTER)

Mode 0 configures an 8-bit timer/counter with a divide-by-32 prescaler. Figure 75 shows Mode 0 operation.



*CORE CLK IS DEFINED BY THE CD BITS IN PLLCON.

Figure 75. Timer/Counter 0, Mode 0

In this mode, the timer register is configured as a 13-bit register. As the count rolls over from all 1s to all 0s, it sets the timer overflow flag, TF0. The overflow flag, TF0, can then be used to request an interrupt. The counted input is enabled to the timer when TR0 = 1 and either gate = 0 or INT0 = 1. Setting gate = 1 allows the timer to be controlled by external Input INT0 to facilitate pulse width measurements. TR0 is a control bit in the TCON SFR; gate is in TMOD. The 13-bit register consists of all eight bits of TH0 and the lower five bits of TL0. The upper three bits of TL0 are indeterminate and should be ignored. Setting the run flag (TR0) does not clear the registers.

MODE 1 (16-BIT TIMER/COUNTER)

Mode 1 is the same as Mode 0, except that the timer register is running with all 16 bits. Mode 1 is shown in Figure 76.

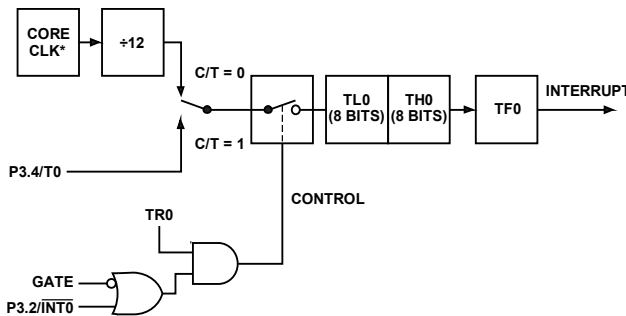

*CORE CLK IS DEFINED BY THE CD BITS IN PLLCON.

Figure 76. Timer/Counter 0, Mode 1

MODE 2 (8-BIT TIMER/COUNTER WITH AUTORELOAD)

Mode 2 configures the timer register as an 8-bit counter (TL0) with automatic reload, as shown in Figure 77. Overflow from TL0 not only sets TF0, but also reloads TL0 with the contents of TH0, which is preset by software. The reload leaves TH0 unchanged.

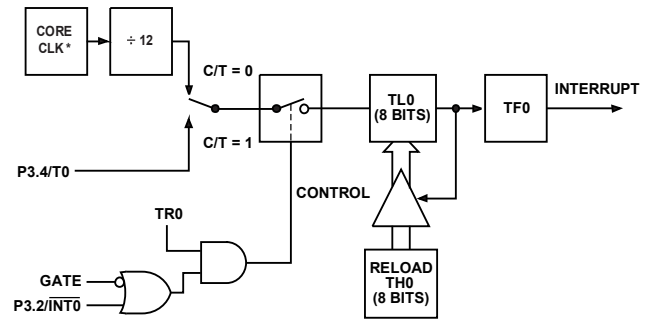

*CORE CLK IS DEFINED BY THE CD BITS IN PLLCON.

Figure 77. Timer/Counter 0, Mode 2

MODE 3 (TWO 8-BIT TIMER/COUNTERS)

Mode 3 has different effects on Timer 0 and Timer 1. Timer 1 in Mode 3 simply holds its count. The effect is the same as setting TR1 = 0. Timer 0 in Mode 3 establishes TL0 and TH0 as two separate counters. This configuration is shown in Figure 78. TL0 uses the Timer 0 control bits: C/T, gate, TR0, INT0, and TF0. TH0 is locked into a timer function (counting machine cycles) and takes over the use of TR1 and TF1 from Timer 1. Thus, TH0 now controls the Timer 1 interrupt. Mode 3 is provided for applications requiring an extra 8-bit timer or counter.

When Timer 0 is in Mode 3, Timer 1 can be turned on and off by switching it out of and into its own Mode 3, or it can still be used by the serial interface as a baud rate generator. It can be used in any application not requiring an interrupt from Timer 1 itself.

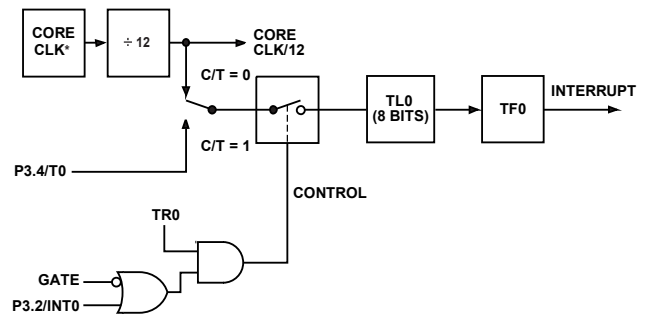

*CORE CLK IS DEFINED BY THE CD BITS IN PLLCON.

Figure 78. Timer/Counter 0, Mode 3

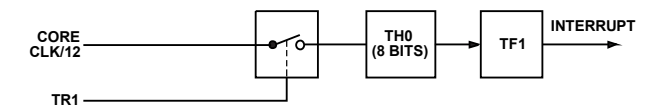

*CORE CLK IS DEFINED BY THE CD BITS IN PLLCON.

Figure 78. Timer/Counter 0, Mode 3

TIMER/COUNTER 2

T2CON (TIMER/COUNTER 2 CONTROL REGISTER)

SFR Address:	C8H
Power-On Default Value:	00H
Bit Addressable:	Yes

TIMER/COUNTER 2 DATA REGISTERS

Timer/Counter 2 also has two pairs of 8-bit data registers associated with it. These are used as both timer data registers and timer capture/reload registers.

TH2 and TL2

TH2 is the Timer 2 data high byte and TL2 is the low byte. The SFR addresses for TH2 and TL2 are CDH and CCH, respectively.

RCAP2H and RCAP2L

RCAP2H is the Timer 2 capture/reload high byte and RCAP2L is the low byte. The SFR addresses for RCAP2H and RCAP2L are CBH and CAH, respectively.

Table 38. T2CON SFR Bit Designations

Bit	Name	Description
[7]	TF2	Timer 2 overflow flag. Set by hardware on a Timer 2 overflow. TF2 is not set when either RCLK = 1 or TCLK = 1. Cleared by user software.
[6]	EXF2	Timer 2 external flag. Set by hardware when either a capture or reload is caused by a negative transition on T2EX and EXEN2 = 1. Cleared by user software.
[5]	RCLK	Receive clock enable bit. Set by the user to enable the serial port to use Timer 2 overflow pulses for its receive clock in serial port Mode 1 and Mode 3. Cleared by the user to enable Timer 1 overflow to be used for the receive clock.
[4]	TCLK	Transmit clock enable bit. Set by the user to enable the serial port to use Timer 2 overflow pulses for its transmit clock in serial port Mode 1 and Mode 3. Cleared by the user to enable Timer 1 overflow to be used for the transmit clock.
[3]	EXEN2	Timer 2 external enable flag. Set by the user to enable a capture or reload to occur as a result of a negative transition on T2EX if Timer 2 is not being used to clock the serial port. Cleared by the user for Timer 2 to ignore events at T2EX.
[2]	TR2	Timer 2 start/stop control bit. Set by the user to start Timer 2. Cleared by the user to stop Timer 2.
[1]	CNT2	Timer 2 timer or counter function select bit. Set by the user to select counter function (input from external T2 pin). Cleared by the user to select timer function (input from on-chip core clock).
[0]	CAP2	Timer 2 capture/reload select bit. Set by the user to enable captures on negative transitions at T2EX if EXEN2 = 1. Cleared by the user to enable autoreloads with Timer 2 overflows or negative transitions at T2EX when EXEN2 = 1. When either RCLK = 1 or TCLK = 1, this bit is ignored and the timer is forced to autoreload on Timer 2 overflow.

TIMER/COUNTER OPERATION MODES

The following sections describe the operating modes for Timer/Counter 2. The operating modes are selected by bits in the T2CON SFR as shown in Table 39.

Table 39. T2CON Operating Modes

RCLK (or) TCLK	CAP2	TR2	Mode
0	0	1	16-bit autoreload
0	1	1	16-bit capture
1	X	1	Baud rate
X	X	0	Off

16-Bit Autoreload Mode

In autoreload mode, there are two options, which are selected by Bit EXEN2 in T2CON. If EXEN2 = 0, then when Timer 2 rolls over, it not only sets TF2 but also causes the Timer 2 registers to be reloaded with the 16-bit value in Register RCAP2L and Register RCAP2H, which are preset by software. If EXEN2 = 1, then Timer 2 still performs the same function as EXEN2 = 0, but with the added feature that a 1-to-0 transition at External Input T2EX also triggers the 16-bit reload and sets EXF2. The autoreload mode is illustrated in Figure 79.

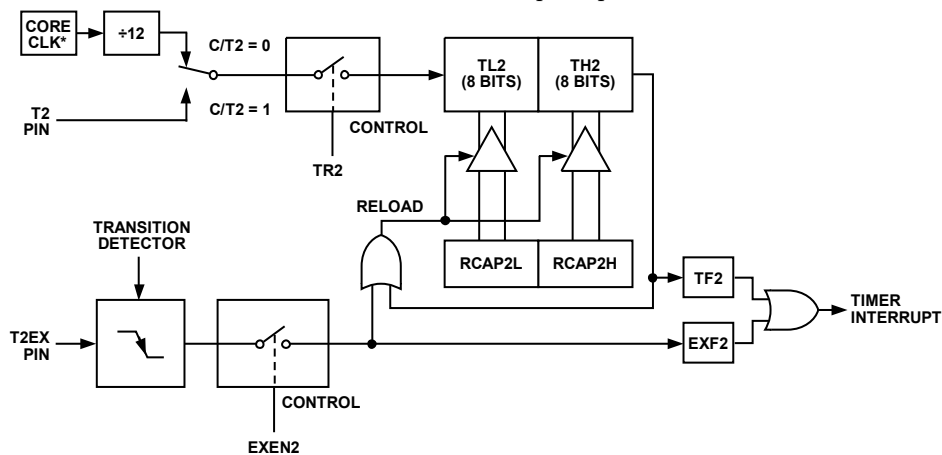

*CORE CLK IS DEFINED BY THE CD BITS IN PLLCON.

Figure 79. Timer/Counter 2, 16-Bit Autoreload Mode

02.987-068

16-Bit Capture Mode

In the capture mode, there are again two options, which are selected by Bit EXEN2 in T2CON. If EXEN2 = 0, then Timer 2 is a 16-bit timer or counter that, upon overflowing, sets Bit TF2, the Timer 2 overflow bit, which can be used to generate an interrupt. If EXEN2 = 1, then Timer 2 still performs the same function as EXEN2 = 0, but a 1-to-0 transition on External Input T2EX causes the current value in the Timer 2 registers, TL2 and TH2, to be captured into Register RCAP2L and Register RCAP2H, respectively. In addition, the transition at T2EX causes Bit EXF2 in T2CON to be set, and EXF2, like TF2, can generate an interrupt. The capture mode is illustrated in Figure 80.

The baud rate generator mode is selected by RCLK = 1 and/or TCLK = 1.

In either case, if Timer 2 is being used to generate the baud rate, the TF2 interrupt flag does not occur. Therefore, Timer 2 interrupts do not occur, so they do not have to be disabled. In this mode, the EXF2 flag, however, can still cause interrupts, and this can be used as a third external interrupt.

Baud rate generation is described as part of the UART serial port operation in the UART Serial Interface section.



*CORE CLK IS DEFINED BY THE CD BITS IN PLLCON.

Figure 80. Timer/Counter 2, 16-Bit Capture Mode

02.987-069

UART SERIAL INTERFACE

The serial port is full duplex, meaning it can transmit and receive simultaneously. It is also receive-buffered, meaning it can commence reception of a second byte before a previously received byte has been read from the receive register. However, if the first byte still has not been read by the time reception of the second byte is complete, the first byte is lost. The physical interface to the serial data network is via the RXD and TXD pins, and the SFR interface to the UART is comprised of SBUF and SCON.

SBUF

The serial port receive and transmit registers are both accessed through the SBUF SFR (SFR address = 99H). Writing to SBUF loads the transmit register and reading SBUF accesses a physically separate receive register.

SCON (UART SERIAL PORT CONTROL REGISTER)

SFR Address: 98H

Power-On Default Value: 00H

Bit Addressable: Yes

Table 40. SCON SFR Bit Designations

Bit	Name	Description															
[7:6]	SM[0:1]	UART serial mode select bits. These bits select the serial port operating mode as follows: <table border="1" data-bbox="305 793 1539 972"> <thead> <tr> <th>SM0</th> <th>SM1</th> <th>Selected Operating Mode</th> </tr> </thead> <tbody> <tr> <td>0</td> <td>0</td> <td>Mode 0: shift register, fixed baud rate (Core_CLK/2)</td> </tr> <tr> <td>0</td> <td>1</td> <td>Mode 1: 8-bit UART, variable baud rate</td> </tr> <tr> <td>1</td> <td>0</td> <td>Mode 2: 9-bit UART, fixed baud rate (Core_CLK/64) or (Core_CLK/32)</td> </tr> <tr> <td>1</td> <td>1</td> <td>Mode 3: 9-bit UART, variable baud rate</td> </tr> </tbody> </table>	SM0	SM1	Selected Operating Mode	0	0	Mode 0: shift register, fixed baud rate (Core_CLK/2)	0	1	Mode 1: 8-bit UART, variable baud rate	1	0	Mode 2: 9-bit UART, fixed baud rate (Core_CLK/64) or (Core_CLK/32)	1	1	Mode 3: 9-bit UART, variable baud rate
SM0	SM1	Selected Operating Mode															
0	0	Mode 0: shift register, fixed baud rate (Core_CLK/2)															
0	1	Mode 1: 8-bit UART, variable baud rate															
1	0	Mode 2: 9-bit UART, fixed baud rate (Core_CLK/64) or (Core_CLK/32)															
1	1	Mode 3: 9-bit UART, variable baud rate															
[5]	SM2	Multiprocessor communication enable bit. Enables multiprocessor communication in Mode 2 and Mode 3. In Mode 0, SM2 should be cleared. In Mode 1, if SM2 is set, RI is not activated if a valid stop bit was not received. If SM2 is cleared, RI is set as soon as the byte of data has been received. In Mode 2 or Mode 3, if SM2 is set, RI is not activated if the received ninth data bit in RB8 is 0. If SM2 is cleared, RI is set as soon as the byte of data has been received.															
[4]	REN	Serial port receive enable bit. Set by user software to enable serial port reception. Cleared by user software to disable serial port reception.															
[3]	TB8	Serial Port Transmit Bit 9. The data loaded into TB8 is the ninth data bit that is transmitted in Mode 2 and Mode 3.															
[2]	RB8	Serial Port Receiver Bit 9. The ninth data bit received in Mode 2 and Mode 3 is latched into RB8. For Mode 1, the stop bit is latched into RB8.															
[1]	TI	Serial port transmit interrupt flag. Set by hardware at the end of the eighth bit in Mode 0, or at the beginning of the stop bit in Mode 1, Mode 2, and Mode 3. TI must be cleared by user software.															
[0]	RI	Serial port receive interrupt flag. Set by hardware at the end of the eighth bit in Mode 0, or halfway through the stop bit in Mode 1, Mode 2, and Mode 3. RI must be cleared by software.															

MODE 0: 8-BIT SHIFT REGISTER MODE

Mode 0 is selected by clearing both the SM0 and SM1 bits in the SCON SFR. Serial data enter and exit through RxD. TxD outputs the shift clock. Eight data bits are transmitted or received. Transmission is initiated by any instruction that writes to SBUF. The data is shifted out of the RxD line. The eight bits are transmitted with the least significant bit (LSB) first, as shown in Figure 81.

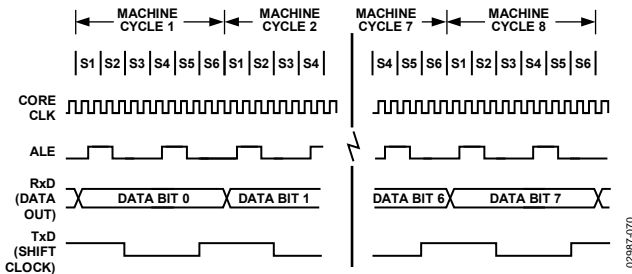

Figure 81. UART Serial Port Transmission, Mode 0

Reception is initiated when the receive enable bit (REN) is 1 and the receive interrupt bit (RI) is 0. When RI is cleared, the data is clocked into the RxD line and the clock pulses are output from the TxD line.

MODE 1: 8-BIT UART, VARIABLE BAUD RATE

Mode 1 is selected by clearing SM0 and setting SM1. Each data byte (LSB first) is preceded by a start bit (0), followed by a stop bit (1). Therefore, 10 bits are transmitted on TxD or received on RxD. The baud rate is set by the Timer 1 or Timer 2 overflow rate, or a combination of the two (one for transmission and the other for reception).

Transmission is initiated by writing to SBUF. The write to SBUF signal also loads a 1 (stop bit) into the ninth bit position of the transmit shift register. The data is output bit by bit until the stop bit appears on TxD and the transmit interrupt flag (TI) is automatically set, as shown in Figure 82.



Figure 82. UART Serial Port Transmission, Mode 0

Reception is initiated when a 1-to-0 transition is detected on RxD. Assuming a valid start bit was detected, character reception continues. The start bit is skipped and the eight data bits are clocked into the serial port shift register. When all eight bits have been clocked in, the following events occur:

- The eight bits in the receive shift register are latched into SBUF.
- The ninth bit (stop bit) is clocked into RB8 in SCON.
- The receiver interrupt flag (RI) is set.

These events occur only if the following conditions are met at the time the final shift pulse is generated:

- RI = 0 and either SM2 = 0 or SM2 = 1
- The received stop bit = 1

If either of these conditions is not met, the received frame is irretrievably lost, and RI is not set.

MODE 2: 9-BIT UART WITH FIXED BAUD RATE

Mode 2 is selected by setting SM0 and clearing SM1. In this mode, the UART operates in 9-bit mode with a fixed baud rate. The baud rate is fixed at Core_CLK/64 by default, although by setting the SMOD bit in PCON, the frequency can be doubled to Core_CLK/32. Eleven bits are transmitted or received, a start bit (0), eight data bits, a programmable ninth bit, and a stop bit (1). The ninth bit is most often used as a parity bit, although it can be used for anything, including a ninth data bit if required.

To transmit, the eight data bits must be written into SBUF. The ninth bit must be written to TB8 in SCON. When transmission is initiated, the eight data bits (from SBUF) are loaded onto the transmit shift register (LSB first). The contents of TB8 are loaded into the ninth bit position of the transmit shift register. The transmission starts at the next valid baud rate clock. The TI flag is set as soon as the stop bit appears on TxD.

Reception for Mode 2 is similar to that of Mode 1. The eight data bytes are input at RxD (LSB first) and loaded onto the receive shift register. When all eight bits have been clocked in, the following events occur:

- The eight bits in the receive shift register are latched into SBUF.
- The ninth data bit is latched into RB8 in SCON.
- The receiver interrupt flag (RI) is set.

These events occur only if the following conditions are met at the time the final shift pulse is generated:

- RI = 0 and either SM2 = 0 or SM2 = 1
- The received stop bit = 1

If either of these conditions is not met, the received frame is irretrievably lost, and RI is not set.

MODE 3: 9-BIT UART WITH VARIABLE BAUD RATE

Mode 3 is selected by setting both SM0 and SM1. In this mode, the 8051 UART serial port operates in 9-bit mode with a variable baud rate determined by either Timer 1 or Timer 2. The operation of the 9-bit UART is the same as for Mode 2 but the baud rate can be varied as for Mode 1.

In all four modes, transmission is initiated by any instruction that uses SBUF as a destination register. Reception is initiated in Mode 0 by the condition RI = 0 and REN = 1. Reception is initiated in the other modes by the incoming start bit if REN = 1.

UART SERIAL PORT BAUD RATE GENERATION

Mode 0 Baud Rate Generation

The baud rate in Mode 0 is fixed.

$$\text{Mode 0 Baud Rate} = (\text{Core_CLK Frequency}/12)$$

Mode 2 Baud Rate Generation

The baud rate in Mode 2 depends on the value of the SMOD bit in the PCON SFR. If SMOD = 0, the baud rate is 1/64 of the core clock. If SMOD = 1, the baud rate is 1/32 of the core clock:

$$\text{Mode 2 Baud Rate} = (2^{\text{SMOD}}/64) \times (\text{Core_CLK Frequency})$$

Mode 1 and Mode 3 Baud Rate Generation

The baud rates in Mode 1 and Mode 3 are determined by the overflow rate in Timer 1 or Timer 2, or both (one for transmit and the other for receive).

TIMER 1 GENERATED BAUD RATES

When Timer 1 is used as the baud rate generator, the baud rates in Mode 1 and Mode 3 are determined by the Timer 1 overflow rate and the value of SMOD as follows:

$$\text{Mode 1 and Mode 3 Baud Rate} = (2^{\text{SMOD}}/32) \times (\text{Timer 1 Overflow Rate})$$

The Timer 1 interrupt should be disabled in this application. The timer itself can be configured for either timer or counter operation, and in any of its three running modes. In the most typical application, it is configured for timer operation in the autoreload mode (high nibble of TMOD = 0010 binary). In that case, the baud rate is given by the formula:

$$\text{Modes 1 and 3 Baud Rate} = (2^{\text{SMOD}}/32) \times (\text{Core_CLK}/(12 \times [256 - \text{TH1}]))$$

Table 41 shows some commonly used baud rates and how they can be calculated from a core clock frequency of 16.78 MHz and 2.0971 MHz. A 5% error is tolerable using asynchronous (start/stop) communications.

Table 41. Commonly Used Baud Rates, Timer 1

Ideal Baud	Core_CLK (MHz)	SMOD Value	TH1 Reload Value	Actual Baud	% Error
9600	16.78	1	-9 (F9H)	9709	1.14
2400	16.78	1	-36 (DCH)	2427	1.14
1200	16.78	1	-73 (B7H)	1197	0.25
1200	2.10	0	-9 (F4H)	1213	1.14

TIMER 2 GENERATED BAUD RATES

Baud rates can also be generated using Timer 2. Using Timer 2 is similar to using Timer 1 in that the timer must overflow 16 times before a bit is transmitted/received. Because Timer 2 has a 16-bit autoreload mode, a wider range of baud rates is possible using Timer 2.

$$\text{Mode 1 and Mode 3 Baud Rate} = (1/16) \times (\text{Timer 2 Overflow Rate})$$

Therefore, when Timer 2 is used to generate baud rates, the timer increments every two clock cycles and not every core machine cycle. Thus, it increments six times faster than Timer 1, and therefore baud rates six times faster are possible. Because Timer 2 has 16-bit autoreload capability, very low baud rates are still possible.

Timer 2 is selected as the baud rate generator by setting the TCLK and/or RCLK bit in T2CON. The baud rates for transmit and receive can be simultaneously different. Setting RCLK and/or TCLK puts Timer 2 into its baud rate generator mode, as shown in Figure 83.

In this case, the baud rate is given by the following formula:

$$\text{Modes 1 and 3 Baud Rate} = (\text{Core_CLK})/(32 \times [6556 - (\text{RCAP2H}, \text{RCAP2L})])$$

Table 42 shows some commonly used baud rates and how they can be calculated from a core clock frequency of 16.78 MHz and 2.10 MHz.

Table 42. Commonly Used Baud Rates, Timer 2

Ideal Baud	Core_CLK (MHz)	RCAP2H Value	RCAP2L Value	Actual Baud	% Error
19,200	16.78	-1 (FFH)	-27 (E5H)	19418	1.14
9600	16.78	-1 (FFH)	-55 (C9H)	9532	0.7
2400	16.78	-1 (FFH)	-218 (26H)	2405	0.21
1200	16.78	-2 (FEH)	-181 (4BH)	1199	0.02
9600	2.10	-1 (FFH)	-7 (FBH)	9362	2.4
2400	2.10	-1 (FFH)	-27 (ECH)	2427	1.14
1200	2.10	-1 (FFH)	-55 (C9H)	1191	0.7

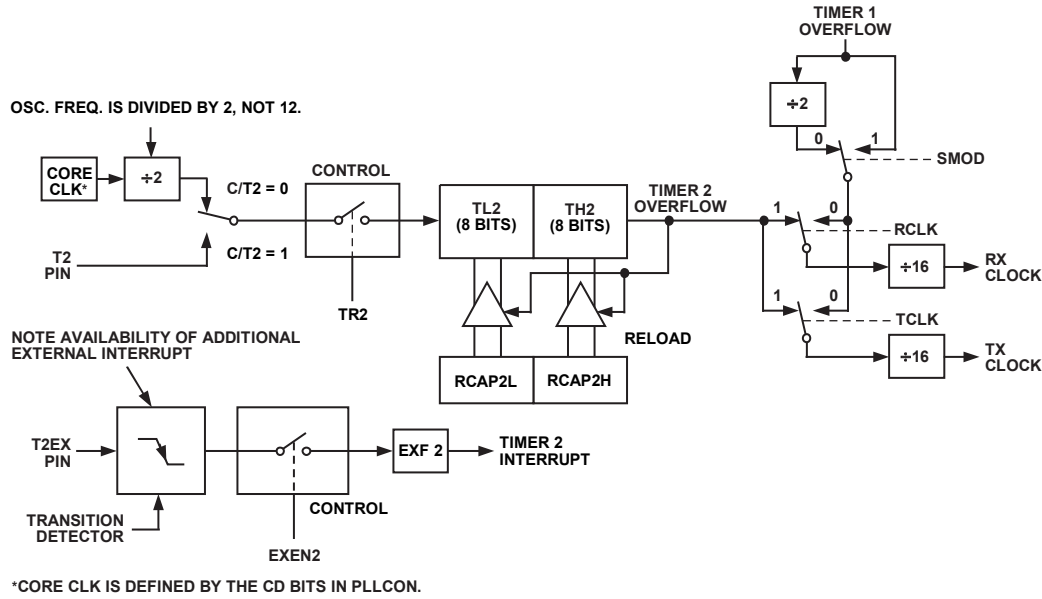

Figure 83. Timer 2, UART Baud Rates

TIMER 3 GENERATED BAUD RATES

The high integer dividers in a UART block mean that high speed baud rates are not always possible using some particular crystals. For example, using a 12 MHz crystal, a baud rate of 115,200 is not possible. To address this problem, the ADuC832 has a dedicated baud rate timer (Timer 3) specifically for generating highly accurate baud rates.

Timer 3 can be used instead of Timer 1 or Timer 2 for generating very accurate high speed UART baud rates including 115,200 and 230,400. Timer 3 also allows a much wider range of baud rates to be obtained. Every desired bit rate from 12 bits/sec to 393,216 bits/sec can be generated to within an error of ±0.8%. Timer 3 also frees up the other three timers, allowing them to be used for different applications. A block diagram of Timer 3 is shown in Figure 84.

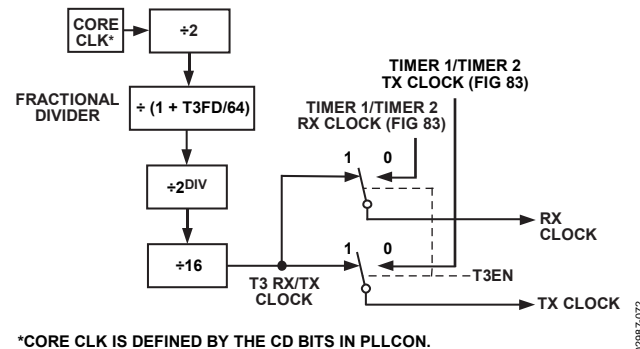

Figure 84. Timer 3, UART Baud Rates

Two SFRs (T3CON and T3FD) are used to control Timer 3. T3CON is the baud rate control SFR, allowing Timer 3 to be used to set up the UART baud rate, and setting up the binary divider (DIV).

Table 43. T3CON SFR Bit Designations

Bit	Name	Description																																				
[7]	T3BAUDEN	T3 UART baud rate enable. Set to enable Timer 3 to generate the baud rate. When set, PCON[7], T2CON[4], and T2CON[5] are ignored. Cleared to let the baud rate be generated as per a standard 8052.																																				
[6:4]	Reserved																																					
[2:0]	DIV[2:0]	Binary divider factor																																				
		<table border="1"> <thead> <tr> <th>DIV2</th> <th>DIV1</th> <th>DIV0</th> <th>Binary Divider</th> </tr> </thead> <tbody> <tr><td>0</td><td>0</td><td>0</td><td>1</td></tr> <tr><td>0</td><td>0</td><td>1</td><td>1</td></tr> <tr><td>0</td><td>1</td><td>0</td><td>1</td></tr> <tr><td>0</td><td>1</td><td>1</td><td>1</td></tr> <tr><td>1</td><td>0</td><td>0</td><td>1</td></tr> <tr><td>1</td><td>0</td><td>1</td><td>1</td></tr> <tr><td>1</td><td>1</td><td>0</td><td>1</td></tr> <tr><td>1</td><td>1</td><td>1</td><td>1</td></tr> </tbody> </table>	DIV2	DIV1	DIV0	Binary Divider	0	0	0	1	0	0	1	1	0	1	0	1	0	1	1	1	1	0	0	1	1	0	1	1	1	1	0	1	1	1	1	1
DIV2	DIV1	DIV0	Binary Divider																																			
0	0	0	1																																			
0	0	1	1																																			
0	1	0	1																																			
0	1	1	1																																			
1	0	0	1																																			
1	0	1	1																																			
1	1	0	1																																			
1	1	1	1																																			

The appropriate value to write to the DIV[2:0] bits can be calculated using the following formula

$$DIV = \frac{\log\left(\frac{f_{CORE}}{32 \times \text{Baud Rate}}\right)}{\log(2)}$$

where f_{CORE} is defined in the PLLCON SFR, PLLCON[2:0].

Note that the DIV value must be rounded down.

T3FD is the fractional divider ratio required to achieve the required baud rate. The appropriate value for T3FD can be calculated using the following formula:

$$T3FD = \frac{2 \times f_{CORE}}{2^{DIV} \times \text{Baud Rate}}$$

Note that T3FD should be rounded to the nearest integer.

After the values for DIV and T3FD are calculated, the actual baud rate can be calculated using the following formula:

$$Actual\ Baud\ Rate = \frac{2 \times f_{CORE}}{2^{DIV} \times (T3FD + 64)}$$

For example, to obtain a baud rate of 115,200 while operating at 16.78 MHz,

$$DIV = \log(11,059,200 / (32 \times 115,200)) / \log(2) = 1.58 = 1$$

$$T3FD = (2 \times 11,059,200) / (2^1 \times 115,200) - 64 = 32 = 20H$$

Therefore, the actual baud rate is 114,912 bits/sec.

Table 44. Commonly Used Baud Rates Using Timer 3

Ideal Baud	CD	DIV	T3CON	T3FD	% Error
230,400	0	1	81H	09H	0.25
115,200	0	2	82H	09H	0.25
115,200	1	1	81H	09H	0.25
115,200	2	0	80H	09H	0.25
57,600	0	3	83H	09H	0.25
57,600	1	2	82H	09H	0.25
57,600	2	1	81H	09H	0.25
57,600	3	0	80H	09H	0.25
38,400	0	3	83H	2DH	0.2
38,400	1	2	82H	2DH	0.2
38,400	2	1	81H	2DH	0.2
38,400	3	0	80H	2DH	0.2
19,200	0	4	84H	2DH	0.2
19,200	1	3	83H	2DH	0.2
19,200	2	2	82H	2DH	0.2
19,200	3	1	81H	2DH	0.2
19,200	4	0	80H	2DH	0.2
9600	0	5	85H	2DH	0.2
9600	1	4	84H	2DH	0.2
9600	2	3	83H	2DH	0.2
9600	3	2	82H	2DH	0.2
9600	4	1	81H	2DH	0.2
9600	5	0	80H	2DH	0.2

INTERRUPT SYSTEM

The ADuC832 provides a total of nine interrupt sources with two priority levels. The control and configuration of the interrupt system is carried out through three interrupt-related SFRs:

- IE—interrupt enable register
- IP—interrupt priority register
- IEIP2—secondary interrupt enable register

IE (INTERRUPT ENABLE REGISTER)

SFR Address: A8H
 Power-On Default Value: 00H
 Bit Addressable: Yes

Table 45. IE SFR Bit Designations

Bit	Name	Description
[7]	EA	Written by user to enable or disable all interrupt sources (1 = enable; 0 = disable)
[6]	EADC	Written by user to enable or disable ADC interrupt (1 = enable; 0 = disable)
[5]	ET2	Written by user to enable or disable Timer 2 interrupt (1 = enable; 0 = disable)
[4]	ES	Written by user to enable or disable UART serial port interrupt (1 = enable; 0 = disable)
[3]	ET1	Written by user to enable or disable Timer 1 interrupt (1 = enable; 0 = disable)
[2]	EX1	Written by user to enable or disable External Interrupt 1 (1 = enable; 0 = disable)
[1]	ET0	Written by user to enable or disable Timer 0 interrupt (1 = enable; 0 = disable)
[0]	EX0	Written by user to enable or disable External Interrupt 0 (1 = enable; 0 = disable)

IP (INTERRUPT PRIORITY REGISTER)

SFR Address: B8H
 Power-On Default Value: 00H
 Bit Addressable: Yes

Table 46. IP SFR Bit Designations

Bit	Name	Description
[7]	Reserved	Reserved for future use.
[6]	PADC	Written by user to select ADC interrupt priority (1 = high; 0 = low)
[5]	PT2	Written by user to select Timer 2 interrupt priority (1 = high; 0 = low)
[4]	PS	Written by user to select UART serial port interrupt priority (1 = high; 0 = low)
[3]	PT1	Written by user to select Timer 1 interrupt priority (1 = high; 0 = low)
[2]	PX1	Written by user to select External Interrupt 1 priority (1 = high; 0 = low)
[1]	PT0	Written by user to select Timer 0 interrupt priority (1 = high; 0 = low)
[0]	PX0	Written by user to select External Interrupt 0 priority (1 = high; 0 = low)

IEIP2 (SECONDARY INTERRUPT ENABLE REGISTER)

SFR Address: A9H
 Power-On Default Value: A0H
 Bit Addressable: No

Table 47. IEIP2 SFR Bit Designations

Bit	Name	Description
[7]	Reserved	Reserved for future use
[6]	PTI	Priority for time interval interrupt
[5]	PPSM	Priority for power supply monitor interrupt
[4]	PSI	Priority for SPI/I ² C interrupt
[3]	Reserved	This bit must contain 0.
[2]	ETI	Written by user to enable or disable time interval counter interrupt. (1 = enable; 0 = disable)
[1]	EPSMI	Written by user to enable or disable power supply monitor interrupt. (1 = enable; 0 = disable)
[0]	ESI	Written by user to enable or disable SPI or I ² C serial port interrupt. (1 = enable; 0 = disable)

INTERRUPT PRIORITY

The interrupt enable registers are written by the user to enable individual interrupt sources, whereas the interrupt priority registers allow the user to select one of two priority levels for each interrupt. An interrupt of a high priority may interrupt the service routine of a low priority interrupt, and if two interrupts of different priority occur at the same time, the higher level interrupt is serviced first. An interrupt cannot be interrupted by another interrupt of the same priority level. If two interrupts of the same priority level occur simultaneously, a polling sequence is observed, as shown in Table 48.

Table 48. Priority Within an Interrupt Level

Source	Priority	Description
PSMI	1 (highest)	Power supply monitor interrupt
WDS	2	Watchdog timer interrupt
IE0	2	External Interrupt 0
ADCI	3	ADC interrupt
TF0	4	Timer/Counter 0 interrupt
IE1	5	External Interrupt 1
TF1	6	Timer/Counter 1 interrupt
ISPI/I2CI	7	SPI Interrupt/I ² C interrupt
RI + TI	8	Serial interrupt
TF2 + EXF2	9 (lowest)	Timer/Counter 2 interrupt
TII	11 (lowest)	Time interval counter interrupt

INTERRUPT VECTORS

When an interrupt occurs, the program counter is pushed onto the stack and the corresponding interrupt vector address is loaded into the program counter. The interrupt vector addresses are shown in Table 49.

Table 49. Interrupt Vector Addresses

Source	Vector Address
IE0	0003H
TF0	000BH
IE1	0013H
TF1	001BH
RI + TI	0023H
TF2 + EXF2	002BH
ADCI	0033H
ISPI/I2CI	003BH
PSMI	0043H
TII	0053H
WDS	005BH

ADuC832 HARDWARE DESIGN CONSIDERATIONS

This section outlines some of the key hardware design considerations that must be addressed when integrating the ADuC832 into any hardware system.

CLOCK OSCILLATOR

The clock source for the ADuC832 can be generated by the internal PLL or by an external clock input. To use the internal PLL, connect a 32.768 kHz parallel resonant crystal between XTAL1 and XTAL2, and connect a capacitor from each pin to ground as shown in Figure 85. This crystal allows the PLL to lock correctly to give a f_{VCO} of 16.78 MHz. If no crystal is present, the PLL free runs, giving a f_{VCO} of 16.7 MHz \pm 20%. This is useful if an external clock input is required. The part powers up and the PLL free runs; the user can then write to the CFG832 SFR in the software to enable the external clock input on P3.4.

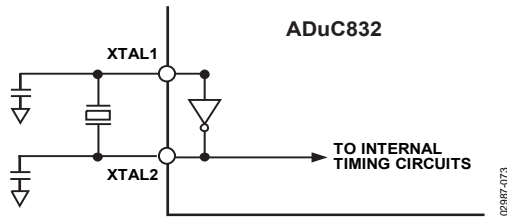

Figure 85. External Parallel Resonant Crystal Connections

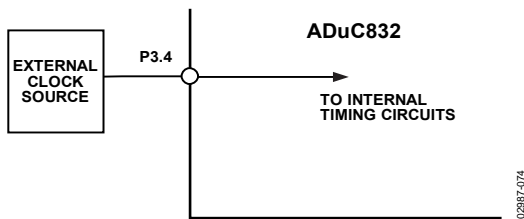

Figure 86. Connecting an External Clock Source

Whether using the internal PLL or an external clock source, the ADuC832 specified operational clock speed range is 400 kHz to 16.78 MHz. The core itself is static, and functions all the way down to dc. However, at clock speeds slower than 400 kHz, the ADC no longer functions correctly. Therefore, to ensure specified operation, use a clock frequency of at least 400 kHz and no more than 16.78 MHz.

EXTERNAL MEMORY INTERFACE

In addition to its internal program and data memories, the ADuC832 can access up to 64 kB of external program memory (such as ROM and PROM) and up to 16 MB of external data memory (SRAM).

To select from which code space (internal or external program memory) to begin executing instructions, tie the \overline{EA} (external access) pin high or low, respectively. When \overline{EA} is high (pulled up to DV_{DD}), the user program execution starts at Address 0 of the internal 62 kB of Flash/EE code space. When \overline{EA} is low (tied to ground), the user program execution starts at Address 0 of the external code space.

A second very important function of the \overline{EA} pin is described in the Single Pin Emulation Mode section.

External program memory (if used) must be connected to the ADuC832 as illustrated in Figure 87. Note that 16 I/O lines (Port 0 and Port 2) are dedicated to bus functions during external program memory fetches. Port 0 (P0) serves as a multiplexed address/data bus. It emits the low byte of the program counter as an address, and then goes into a float state awaiting the arrival of the code byte from the program memory. During the time that the low byte of the program counter is valid on P0, the signal address latch enable (ALE) clocks this byte into an address latch. Meanwhile, Port 2 (P2) emits the high byte of the program counter, then \overline{PSEN} strobes the EPROM and the code byte is read into the ADuC832.

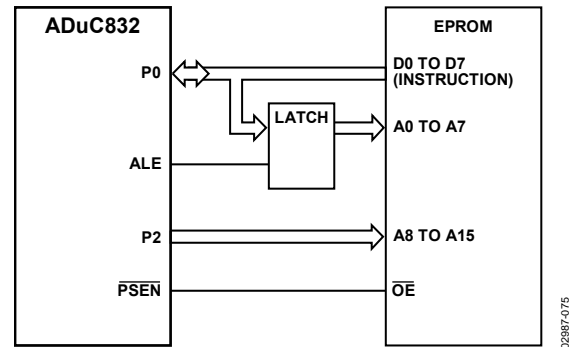

Figure 87. External Program Memory Interface

Note that program memory addresses are always 16 bits wide, even in cases where the actual amount of program memory used is less than 64 kB. External program execution sacrifices two of the 8-bit ports (P0 and P2) to the function of addressing the program memory. While executing from external program memory, Port 0 and Port 2 can be used simultaneously for read/write access to external data memory, but not for general-purpose I/O.

Though both external program memory and external data memory are accessed by some of the same pins, the two are completely independent of each other from a software point of view. For example, the chip can read/write external data memory while executing from external program memory.

Figure 88 shows a hardware configuration for accessing up to 64 kB of external RAM. This interface is standard to any 8051-compatible MCU.



Figure 88. External Data Memory Interface (64 kB Address Space)

If access to more than 64 kB of RAM is desired, a feature unique to the ADuC832 allows addressing up to 16 MB of external RAM simply by adding an additional latch, as illustrated in Figure 89.



Figure 89. External Data Memory Interface (16 MB Address Space)

In either implementation, Port 0 (P0) serves as a multiplexed address/data bus. It emits the low byte of the data pointer (DPL) as an address, which is latched by a pulse of ALE prior to data being placed on the bus by the ADuC832 (write operation) or the SRAM (read operation). Port 2 (P2) provides the data pointer page byte (DPP) to be latched by ALE, followed by the data pointer high byte (DPH). If no latch is connected to P2, DPP is ignored by the SRAM, and the 8051 standard of 64 kB external data memory access is maintained.

POWER SUPPLIES

The ADuC832 operational power supply voltage range is 2.7 V to 5.25 V. Although the guaranteed data sheet specifications are given only for power supplies within 2.7 V to 3.6 V or 10% of the nominal 5 V level, the chip functions equally well at any power supply level between 2.7 V and 5.5 V.

Note that Figure 90 and Figure 91 refer to the MQFP package. For the LFCSP package, connect the extra DV_{DD}, DGND, AV_{DD}, and AGND in the same manner.

Separate analog and digital power supply pins (AV_{DD} and DV_{DD}, respectively) allow AV_{DD} to be relatively free of noisy digital signals often present on the system DV_{DD} line. However, though AV_{DD} and DV_{DD} can be powered from two separate supplies if desired, they must remain within 0.3 V of one another at all times to

avoid damaging the chip (as per the Absolute Maximum Ratings section). Therefore, it is recommended that, unless AV_{DD} and DV_{DD} are connected directly together, back-to-back Schottky diodes be connected between them as shown in Figure 90.

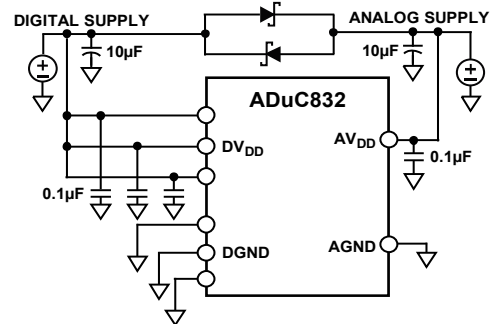

Figure 90. External Dual-Supply Connections

As an alternative to providing two separate power supplies, the user can keep AV_{DD} quiet by placing a small series resistor and/or ferrite bead between it and DV_{DD}, and then decoupling AV_{DD} separately to ground. An example of this configuration is shown in Figure 91. With this configuration, other analog circuitry (such as op amps and voltage reference) can be powered from the AV_{DD} supply line as well. The user should still include back-to-back Schottky diodes between AV_{DD} and DV_{DD} to protect from power-up and power-down transient conditions that may separate the two supply voltages momentarily.



Figure 91. External Single-Supply Connections

Note that, in both Figure 90 and Figure 91, a large value (10 µF) reservoir capacitor is connected to DV_{DD} and a separate 10 µF capacitor is connected to AV_{DD}. Also, local small-value (0.1 µF) capacitors are located at each AV_{DD} pin of the chip. As per standard design practice, be sure to include all of these capacitors, and ensure that the smaller capacitors are close to each AV_{DD} pin with trace lengths as short as possible. Connect the ground terminal of each of these capacitors directly to the underlying ground plane. Finally, it should also be noted that, at all times, the analog and digital ground pins on the ADuC832 must be referenced to the same system ground reference point.

POWER CONSUMPTION

The currents consumed by the various sections of the ADuC832 are shown in Table 50. The core values given represent the current drawn by DV_{DD}, and the rest (ADC, DAC, voltage reference) are pulled by the AV_{DD} pin and can be disabled in software when not in use. The other on-chip peripherals (for example, watchdog timer and power supply monitor) consume negligible current and are therefore included with the core operating current. The user must add any currents sourced by the parallel and serial I/O pins and by the DAC to determine the total current needed at the ADuC832 supply pins. Also, current drawn from the DV_{DD} supply increases by approximately 10 mA during Flash/EE erase and program cycles.

Table 50. Typical I_{DD} of Core and Peripherals

Core/Peripherals	V _{DD} = 5 V	V _{DD} = 3 V
Core, Normal Mode	(1.6 nA × M _{CLK}) + 6 mA	(0.8 nA × M _{CLK}) + 3 mA
Core, Idle Mode	(0.75 nA × M _{CLK}) + 5 mA	(0.25 nA × M _{CLK}) + 3 mA
ADC	1.3 mA	1.0 mA
DAC (Each)	250 μA	200 μA
Voltage Reference	200 μA	150 μA

Because the operating DV_{DD} current is primarily a function of clock speed, the expressions for core supply current in Table 50 are given as functions of M_{CLK}, the core clock frequency. Use a value for M_{CLK} in hertz to determine the current consumed by the core at that oscillator frequency. Because the ADC and DACs can be enabled or disabled in software, add only the currents from the peripherals that are expected to be used. Do not forget to include current sourced by I/O pins, serial port pins, and DAC outputs, plus the additional current drawn during Flash/EE erase and program cycles. A software switch allows the chip to be switched from normal mode into idle mode, and into full power-down mode. The following sections provide brief descriptions of power-down and idle modes.

POWER SAVING MODES

In idle mode, the oscillator continues to run but the core clock generated from the PLL is halted. The on-chip peripherals continue to receive the clock, and remain functional. The CPU status is preserved with the stack pointer and program counter, and all other internal registers maintain their data during idle mode. Port pins and DAC output pins retain their states in this mode. The chip recovers from idle mode upon receiving any enabled interrupt, or upon receiving a hardware reset.

In full power-down mode, both the PLL and the clock to the core are stopped. The on-chip oscillator can be halted or can continue to oscillate depending on the state of the oscillator power-down bit (OSC_PD) in the PLLCON SFR. The TIC, being driven directly from the oscillator, can also be enabled during power-down. All other on-chip peripherals, however, are shut down. Port pins retain their logic levels in this mode, but the DAC output goes to a high impedance state (three-state).

During full power-down mode, the ADuC832 consumes a total of approximately 20 μA. There are five ways of terminating power-down mode.

Asserting the RESET Pin

Asserting the RESET pin returns the part to normal mode. All registers are set to their default state and program execution starts at the reset vector when the RESET pin is deasserted.

Cycling Power

All registers are set to their default state and program execution starts at the reset vector approximately 128 ms later.

Time Interval Counter (TIC) Interrupt

Power-down mode is terminated and the CPU services the TIC interrupt. The RETI at the end of the TIC ISR returns the core to the instruction following the one that enabled power-down.

I²C or SPI Interrupt

Power-down mode is terminated and the CPU services the I²C/SPI interrupt. The RETI at the end of the ISR returns the core to the instruction following the one that enabled power-down. It should be noted that the I²C/SPI power-down interrupt enable bit (SERIPD) in the PCON SFR must first be set to allow this mode of operation.

INT0 Interrupt

Power-down mode is terminated and the CPU services the INT0 interrupt. The RETI at the end of the ISR returns the core to the instruction following the one that enabled power-down. The INT0 pin must not be driven low during or within two machine cycles of the instruction that initiates power-down mode. It should be noted that the INT0 power-down interrupt enable bit (INT0PD) in the PCON SFR must first be set to allow this mode of operation.

POWER-ON RESET

An internal power-on reset (POR) is implemented on the ADuC832. For DV_{DD} below 2.45 V, the internal POR holds the ADuC832 in reset. As DV_{DD} rises above 2.45 V, an internal timer times out for approximately 128 ms before the part is released from reset. The user must ensure that the power supply has reached a stable 2.7 V minimum level by this time. Likewise upon power-down, the internal POR holds the ADuC832 in reset until the power supply drops below 1 V. Figure 92 illustrates the operation of the internal POR in detail.

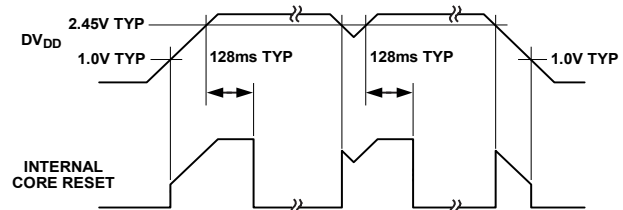

Figure 92. Internal POR Operation

GROUNDING AND BOARD LAYOUT RECOMMENDATIONS

As with all high resolution data converters, special attention must be paid to grounding and PCB layout of ADuC832- based designs to achieve optimum performance from the ADC and DACs. Although the ADuC832 has separate pins for analog and digital ground (AGND and DGND), the user must not tie these to two separate ground planes unless the two ground planes are connected together very close to the ADuC832, as illustrated in the simplified example of Figure 93a. In systems where digital and analog ground planes are connected together at some other location (at the system's power supply, for example), they cannot be connected again near the ADuC832 because a ground loop then results. In these cases, tie all the ADuC832 AGND and DGND pins to the analog ground plane, as illustrated in Figure 93b. In systems with only one ground plane, ensure that the digital and analog components are physically separated onto separate halves

of the board such that digital return currents do not flow near analog circuitry and vice versa. The ADuC832 can then be placed between the digital and analog sections, as illustrated in Figure 93c.

In all of these scenarios, and in more complicated real-life applications, keep in mind the flow of current from the supplies and back to ground. Make sure the return paths for all currents are as close as possible to the paths the currents traveled to reach their destinations. For example, do not power components on the analog side of Figure 93b with DV_{DD} because that forces return currents from DV_{DD} to flow through AGND. Also, try to avoid digital currents flowing under analog circuitry, which may happen if the user places a noisy digital chip on the left half of the board in Figure 93c. Whenever possible, avoid large discontinuities in the ground plane(s) (such as are formed by a

long trace on the same layer), because they force return signals to travel a longer path. Also, make all connections to the ground plane directly, with little or no trace separating the pin from its via to ground.

To connect fast logic signals (rise/fall time < 5 ns) to any of the ADuC832 digital inputs, add a series resistor to each relevant line to keep rise and fall times longer than 5 ns at the ADuC832 input pins. A value of $100\ \Omega$ or $200\ \Omega$ is usually sufficient to prevent high speed signals from coupling capacitively into the ADuC832 and affecting the accuracy of ADC conversions.



Figure 93. System Grounding Schemes

02987-081



Figure 94. Example ADuC832 System (MQFP Package)

02987-082

OTHER HARDWARE CONSIDERATIONS

To facilitate in-circuit programming, plus in-circuit debug and emulation options, implement some simple connection points in the hardware that allow easy access to download, debug, and emulation modes.

IN-CIRCUIT SERIAL DOWNLOAD ACCESS

Nearly all ADuC832 designs can take advantage of the in-circuit reprogrammability of the chip. This is accomplished by a connection to the ADuC832 UART, which requires an external RS-232 chip for level translation if downloading code from a PC. Basic configuration of an RS-232 connection is illustrated in Figure 94 with a simple ADM202-based circuit. To avoid designing an RS-232 chip onto a board, refer to the uC006 Technical Note, *A 4-Wire UART-to-PC Interface*, for a simple (and zero-cost-per-board) method of gaining in-circuit serial download access to the ADuC832.

In addition to the basic UART connections, users also need a way to trigger the chip into download mode. This is accomplished via a 1 k Ω pull-down resistor that can be jumpered onto the PSEN pin, as shown in Figure 94. To put the ADuC832 into download mode, connect this jumper and power-cycle the device (or manually reset the device, if a manual reset button is available) so that it can receive a new program serially. With the jumper removed, the device comes up in normal mode (and runs the program) whenever power is cycled or RESET is toggled.

Note that PSEN is normally an output (as described in the External Memory Interface section) and is sampled as an input only on the falling edge of RESET (that is, at power-up or upon an external manual reset). Note also that if any external circuitry unintentionally pulls PSEN low during power-up or reset events, it may cause the chip to enter download mode and therefore fail to begin user code execution as it should. To prevent this, ensure that no external signals are capable of pulling the PSEN pin low, except for the external PSEN jumper itself.

EMBEDDED SERIAL PORT DEBUGGER

From a hardware perspective, entry into serial port debug mode is identical to the serial download entry sequence described in the In-Circuit Serial Download Access section. In fact, both serial download and serial port debug modes can be thought of as essentially one mode of operation used in two different ways.

Note that the serial port debugger is fully contained on the ADuC832 device (unlike ROM monitor type debuggers) and therefore no external memory is needed to enable in-system debug sessions.

SINGLE-PIN EMULATION MODE

Also built into the ADuC832 is a dedicated controller for single-pin in-circuit emulation (ICE) using standard production ADuC832 devices. In this mode, emulation access is gained by connection to a single pin, the EA pin. Normally, this pin is hardwired either high or low to select execution from internal or external program memory space. To enable single-pin emulation mode, however, users need to pull the EA pin high through a 1 k Ω resistor, as shown in Figure 94. The emulator then connects to the 2-pin header, also shown in Figure 94. To be compatible with the standard connector that comes with the single-pin emulator, use a 2-pin 0.1 inch pitch friction lock header from Molex such as Part Number 22-27-2021. Be sure to observe the polarity of this header. As represented in Figure 94, when the friction lock tab is located on the right, the ground pin should be the lower of the two pins (when viewed from the top).

TYPICAL SYSTEM CONFIGURATION

A typical ADuC832 configuration is shown in Figure 94. It summarizes some of the hardware considerations discussed in the Single-Pin Emulation Mode section.

DEVELOPMENT TOOLS

There are two models of development tools available for the [ADuC832](#).

- QuickStart—entry-level development system
- QuickStart Plus—comprehensive development system

QUICKSTART DEVELOPMENT SYSTEM

The QuickStart development system is an entry-level, low cost development tool suite supporting the [ADuC832](#). The system consists of the following PC-based (Windows® compatible) hardware and software development tools.

Table 51. QuickStart Components

Component	Description
Hardware	ADuC832 evaluation board and serial port programming cable
Software	Serial download software; incorporates 8051 assembler and serial port debugger
Miscellaneous	CD-ROM documentation and prototype device

Hardware contents include:

- Evaluation board
- Serial download/debug cable
- International power supply

Software contents include:

- Serial downloader
- Analog performance analysis package
- Example code, function libraries, data sheets, and application notes

Visit www.analog.com/microcontroller for details on a typical debug session.

Download—In-Circuit Serial Downloader

The serial downloader is a Windows application that allows the user to serially download an assembled program (Intel Hex format file) to the on-chip program FLASH memory via the serial COM1 port on a standard PC. See the Application Note [AN-1074](#), which details this serial download protocol.

QUICKSTART PLUS DEVELOPMENT SYSTEM

The QuickStart Plus Development system offers users enhanced nonintrusive debug and emulation tools. The system consists of the following PC-based (Windows compatible) hardware and software development tools.

Table 52. QuickStart Plus Components

Component	Description
Hardware	ADuC832 prototype board
Software	Features full C code
Miscellaneous	CD-ROM documentation

OUTLINE DIMENSIONS



COMPLIANT TO JEDEC STANDARDS MO-112-AC-2

Figure 95. 52-Lead Metric Quad Flat Package [MQFP] (S-52-2)

Dimensions shown in millimeters

06-10-20014-B

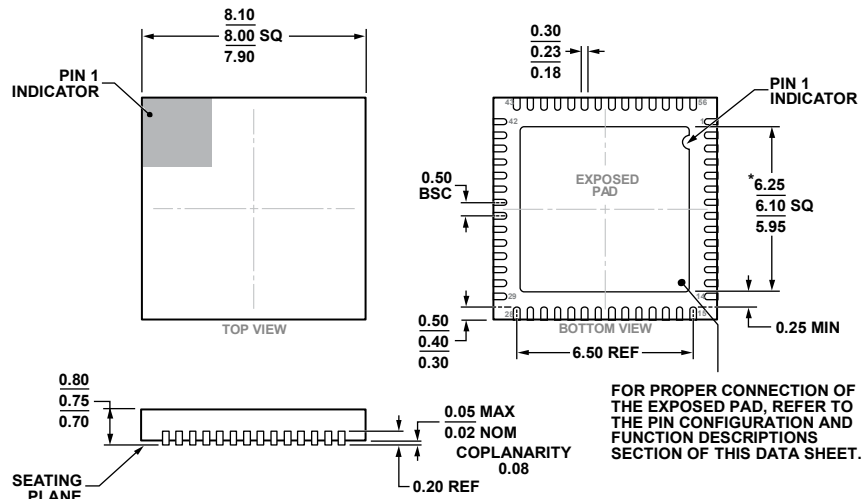

*COMPLIANT TO JEDEC STANDARDS MO-220-WLLD-2 WITH EXCEPTION TO EXPOSED PAD DIMENSION.

Figure 96. 56-Lead Lead Frame Chip Scale Package [LFCSP] 8 mm x 8 mm Body and 0.75 mm Package Height (CP-56-11)

Dimensions shown in millimeters

08-23-2013-A

ORDERING GUIDE

Model ¹	Temperature Range	Package Description	Package Option
ADuC832BCPZ	-40°C to +85°C	56-Lead Lead Frame Chip Scale Package [LFCSP]	CP-56-11
ADuC832BCPZ-REEL	-40°C to +85°C	56-Lead Lead Frame Chip Scale Package [LFCSP]	CP-56-11
ADuC832BSZ	-40°C to +125°C	52-Lead Metric Quad Flat Pack age [MQFP]	S-52-2
ADuC832BSZ-REEL	-40°C to +125°C	52-Lead Metric Quad Flat Pack age [MQFP]	S-52-2
EVAL-ADuC832QSZ		QuickStart Development System	

¹ Z = RoHS Compliant Part.

NOTES

NOTES

NOTES

I²C refers to a communications protocol originally developed by Philips Semiconductors (now NXP Semiconductors).

Компания «Life Electronics» занимается поставками электронных компонентов импортного и отечественного производства от производителей и со складов крупных дистрибьюторов Европы, Америки и Азии.

С конца 2013 года компания активно расширяет линейку поставок компонентов по направлению коаксиальный кабель, кварцевые генераторы и конденсаторы (керамические, пленочные, электролитические), за счёт заключения дистрибьюторских договоров

Мы предлагаем:

- Конкуренспособные цены и скидки постоянным клиентам.
- Специальные условия для постоянных клиентов.
- Подбор аналогов.
- Поставку компонентов в любых объемах, удовлетворяющих вашим потребностям.
- Приемлемые сроки поставки, возможна ускоренная поставка.
- Доставку товара в любую точку России и стран СНГ.
- Комплексную поставку.
- Работу по проектам и поставку образцов.
- Формирование склада под заказчика.
- Сертификаты соответствия на поставляемую продукцию (по желанию клиента).
- Тестирование поставляемой продукции.
- Поставку компонентов, требующих военную и космическую приемку.
- Входной контроль качества.
- Наличие сертификата ISO.

В составе нашей компании организован Конструкторский отдел, призванный помогать разработчикам, и инженерам.

Конструкторский отдел помогает осуществить:

- Регистрацию проекта у производителя компонентов.
- Техническую поддержку проекта.
- Защиту от снятия компонента с производства.
- Оценку стоимости проекта по компонентам.
- Изготовление тестовой платы монтаж и пусконаладочные работы.



Тел: +7 (812) 336 43 04 (многоканальный)
Email: org@lifeelectronics.ru