



MCP6S2X Evaluation Board (Rev. 4) User's Guide

Note the following details of the code protection feature on Microchip devices:

- Microchip products meet the specification contained in their particular Microchip Data Sheet.
- Microchip believes that its family of products is one of the most secure families of its kind on the market today, when used in the intended manner and under normal conditions.
- There are dishonest and possibly illegal methods used to breach the code protection feature. All of these methods, to our knowledge, require using the Microchip products in a manner outside the operating specifications contained in Microchip's Data Sheets. Most likely, the person doing so is engaged in theft of intellectual property.
- Microchip is willing to work with the customer who is concerned about the integrity of their code.
- Neither Microchip nor any other semiconductor manufacturer can guarantee the security of their code. Code protection does not mean that we are guaranteeing the product as "unbreakable."

Code protection is constantly evolving. We at Microchip are committed to continuously improving the code protection features of our products. Attempts to break Microchip's code protection feature may be a violation of the Digital Millennium Copyright Act. If such acts allow unauthorized access to your software or other copyrighted work, you may have a right to sue for relief under that Act.

Information contained in this publication regarding device applications and the like is intended through suggestion only and may be superseded by updates. It is your responsibility to ensure that your application meets with your specifications. No representation or warranty is given and no liability is assumed by Microchip Technology Incorporated with respect to the accuracy or use of such information, or infringement of patents or other intellectual property rights arising from such use or otherwise. Use of Microchip's products as critical components in life support systems is not authorized except with express written approval by Microchip. No licenses are conveyed, implicitly or otherwise, under any intellectual property rights.

Trademarks

The Microchip name and logo, the Microchip logo, Accuron, dsPIC, KEELOQ, microID, MPLAB, PIC, PICmicro, PICSTART, PRO MATE, PowerSmart, rfPIC, and SmartShunt are registered trademarks of Microchip Technology Incorporated in the U.S.A. and other countries.

AmpLab, FilterLab, MXDEV, MXLAB, PICMASTER, SEEVAL, SmartSensor and The Embedded Control Solutions Company are registered trademarks of Microchip Technology Incorporated in the U.S.A.

Analog-for-the-Digital Age, Application Maestro, dsPICDEM, dsPICDEM.net, dsPICworks, ECAN, ECONOMONITOR, FanSense, FlexROM, fuzzyLAB, In-Circuit Serial Programming, ICSP, ICEPIC, Migratable Memory, MPASM, MPLIB, MPLINK, MPSIM, PICKit, PICDEM, PICDEM.net, PICLAB, PICtail, PowerCal, PowerInfo, PowerMate, PowerTool, rLAB, rfPICDEM, Select Mode, Smart Serial, SmartTel and Total Endurance are trademarks of Microchip Technology Incorporated in the U.S.A. and other countries.

SQTP is a service mark of Microchip Technology Incorporated in the U.S.A.

All other trademarks mentioned herein are property of their respective companies.

© 2004, Microchip Technology Incorporated, Printed in the U.S.A., All Rights Reserved.

 Printed on recycled paper.

QUALITY MANAGEMENT SYSTEM
CERTIFIED BY DNV
== ISO/TS 16949:2002 ==

Microchip received ISO/TS-16949:2002 quality system certification for its worldwide headquarters, design and wafer fabrication facilities in Chandler and Tempe, Arizona and Mountain View, California in October 2003. The Company's quality system processes and procedures are for its PICmicro® 8-bit MCUs, KEELOQ® code hopping devices, Serial EEPROMs, microperipherals, nonvolatile memory and analog products. In addition, Microchip's quality system for the design and manufacture of development systems is ISO 9001:2000 certified.



MCP6S2X Evaluation Board (Rev.4) User's Guide

Table of Contents

Preface	1
Introduction.....	1
About This Guide.....	2
Recommended Reading.....	4
The Microchip Internet Web Site	4
Customer Support	5
Chapter 1. MCP6S2X Evaluation Board (Rev. 4)	7
1.1 Introduction	7
1.2 Evaluation Board Description	8
1.3 How it is used	9
1.4 How it works	10
Appendix A. Schematic and Board Layouts	15
A.1 Introduction	12
A.2 Schematic	16
A.3 Top Silk Screen	17
A.4 Top Metal Layer	18
A.5 Ground Plane Layer	19
A.6 Power Plane Layer	20
A.7 Bottom Metal Layer	21
A.8 Bottom Silk Screen Layer (Top View)	22
Appendix B. Bill of Materials (BOM)	23
B.1 Introduction	23
Appendix C. Evaluation Board Firmware	25

MCP6S2X Evaluation Board (Rev.4) User's Guide

Appendix D. Setup Conditions.....	29
D.1 DIP Switch Configurations (Stand-Alone Mode)	29
D.2 Momentary Push Button Switch	30
D.3 SMA Connectors	30
D.4 Test Points	31
D.5 Reference Voltage Jumper positions	31
Worldwide Sales and Service	32



MCP6S2X Evaluation Board (Rev. 4) User's Guide

Preface

NOTICE TO CUSTOMERS

All documentation becomes dated, and this manual is no exception. Microchip tools and documentation are constantly evolving to meet customer needs, so some actual dialogs and/or tool descriptions may differ from those in this document. Please refer to our web site (www.microchip.com) to obtain the latest documentation available.

Documents are identified with a "DS" number. This number is located on the bottom of each page, in front of the page number. The numbering convention for the DS number is "DSXXXXA", where "XXXX" is the document number and "A" is the revision level of the document.

For the most up-to-date information on development tools, see the MPLAB IDE on-line help. Select the Help menu, and then Topics to open a list of available on-line help files.

INTRODUCTION

This chapter contains general information that will be useful to know before using the MCP6S2X Evaluation Board (Rev. 4). Items discussed in this chapter include:

- About This Guide
- Warranty Registration
- Recommended Reading
- Troubleshooting
- The Microchip Web Site
- Development Systems Customer Change Notification Service
- Customer Support

MCP6S2X Evaluation Board (Rev. 4) User's Guide

ABOUT THIS GUIDE

Document Layout

This document describes how to use MCP6S2X Evaluation Board (Rev. 4) as a development tool to emulate and debug firmware on a target board. The manual layout is as follows:

- **Chapter 1: MCP6S2X Evaluation Board (Rev. 4)** - this section describes how to use the various features of the MCP6S2X Evaluation Board (Rev. 4).
- **Appendix A: Schematic** – shows the schematic and printed circuit board (PCB) layout diagrams for the MCP6S2X Evaluation Board (Rev. 4).
- **Appendix B: Bill of Materials (BOM)** – shows the parts used to build the MCP6S2X Evaluation Board (Rev. 4).
- **Appendix C: Evaluation Board Firmware** – shows the firmware for the PIC16C505 source code used on the MCP6S2X Evaluation Board (Rev. 4).
- **Appendix D: Setup Conditions** – shows configuration tables for the DIP switch settings and connections used for the MCP6S2X Evaluation Board (Rev. 4).

Conventions Used in this Guide

This manual uses the following documentation conventions:

DOCUMENTATION CONVENTIONS

Description	Represents	Examples
Arial font:		
Italic characters	Referenced books	<i>MPLAB IDE User's Guide</i>
	Emphasized text	...is the <i>only</i> compiler...
Initial caps	A window	the Output window
	A dialog	the Settings dialog
	A menu selection	select Enable Programmer
Quotes	A field name in a window or dialog	"Save project before build"
Underlined, italic text with right angle bracket	A menu path	<u><i>File>Save</i></u>
Bold characters	A dialog button	Click OK
	A tab	Click the Power tab
'bnnnn	A binary number where <i>n</i> is a digit	'b00100, 'b10
Text in angle brackets < >	A key on the keyboard	Press <Enter>, <F1>
Courier font:		
Plain Courier	Sample source code	#define START
	Filenames	autoexec.bat
	File paths	c:\mcc18\h
	Keywords	_asm, _endasm, static
	Command-line options	-Opa+, -Opa-
	Bit values	0, 1
Italic Courier	A variable argument	<i>file.o</i> , where <i>file</i> can be any valid filename
0xn timer	A hexadecimal number where <i>n</i> is a hexadecimal digit	0xFFFF, 0x007A
Square brackets []	Optional arguments	mcc18 [options] <i>file</i> [options]
Curly brackets and pipe character: { }	Choice of mutually exclusive arguments; an OR selection	errorlevel {0 1}
Ellipses...	Replaces repeated text	var_name [, var_name...]
	Represents code supplied by user	void main (void) { ... }

MCP6S2X Evaluation Board (Rev. 4) User's Guide

RECOMMENDED READING

This user's guide describes how to use MCP6S2X Evaluation Board (Rev. 4). Other useful documents are listed below. The following Microchip documents are available and recommended as supplemental reference resources.

MCP6S2X PGA Data Sheet (DS21117)

This data sheet provides detailed information regarding the MCP6S21/2/6/8 family of PGAs.

THE MICROCHIP WEB SITE

Microchip provides online support via our WWW site at www.microchip.com. This web site is used as a means to make files and information easily available to customers. Accessible by using your favorite Internet browser, the web site contains the following information:

- **Product Support** – Data sheets and errata, application notes and sample programs, design resources, user's guides and hardware support documents, latest software releases and archived software
- **General Technical Support** – Frequently Asked Questions (FAQ), technical support requests, online discussion groups, Microchip consultant program member listing
- **Business of Microchip** – Product selector and ordering guides, latest Microchip press releases, listing of seminars and events, listings of Microchip sales offices, distributors and factory representatives

DEVELOPMENT SYSTEMS CUSTOMER CHANGE NOTIFICATION SERVICE

Microchip's customer notification service helps keep customers current on Microchip products. Subscribers will receive e-mail notification whenever there are changes, updates, revisions or errata related to a specified product family or development tool of interest.

To register, access the Microchip web site at www.microchip.com, click on Customer Change Notification and follow the registration instructions.

The Development Systems product group categories are:

- **Compilers** – The latest information on Microchip C compilers and other language tools. These include the MPLAB C17, MPLAB C18 and MPLAB C30 C compilers; MPASM™ and MPLAB ASM30 assemblers; MPLINK™ and MPLAB LINK30 object linkers; and MPLIB™ and MPLAB LIB30 object librarians.
- **Emulators** – The latest information on Microchip in-circuit emulators. This includes the MPLAB ICE 2000 and MPLAB ICE 4000.
- **In-Circuit Debuggers** – The latest information on the Microchip in-circuit debugger, MPLAB ICD 2.
- **MPLAB IDE** – The latest information on Microchip MPLAB IDE, the Windows® Integrated Development Environment for development systems tools. This list is focused on the MPLAB IDE, MPLAB SIM and MPLAB SIM30 simulators, MPLAB IDE Project Manager and general editing and debugging features.
- **Programmers** – The latest information on Microchip programmers. These include the MPLAB PM3 and PRO MATE® II device programmers and the PICSTART® Plus development programmer.

CUSTOMER SUPPORT

Users of Microchip products can receive assistance through several channels:

- Distributor or Representative
- Local Sales Office
- Field Application Engineer (FAE)
- Technical Support
- Development Systems Information Line

Customers should contact their distributor, representative or field application engineer (FAE) for support. Local sales offices are also available to help customers. A listing of sales offices and locations is included in the back of this document.

Technical support is available through the web site at: <http://support.microchip.com>

In addition, there is a Development Systems Information Line which lists the latest versions of Microchip's development systems software products. This line also provides information on how customers can receive currently available upgrade kits.

The Development Systems Information Line numbers are:

1-800-755-2345 – United States and most of Canada

1-480-792-7302 – Other International Locations

MCP6S2X Evaluation Board (Rev. 4) User's Guide

NOTES:

Chapter 1. MCP6S2X Evaluation Board (Rev. 4)

1.1 INTRODUCTION

The MCP6S21/2/6/8 family of Programmable Gain Amplifiers (PGA) is available with one, two, six or eight signal input channels, respectively. The user can digitally select a specific input channel and set the gain. This family of PGAs can be evaluated using the MCP6S2X Evaluation Board (Rev. 4). The evaluation board schematic is shown in Figure 1-1. This board uses the MCP6S21 and MCP6S26 to allow the user to connect two signal sources to evaluate the PGAs. The 10 kΩ pull-up resistors provide noise immunity for the PGA digital input pins.

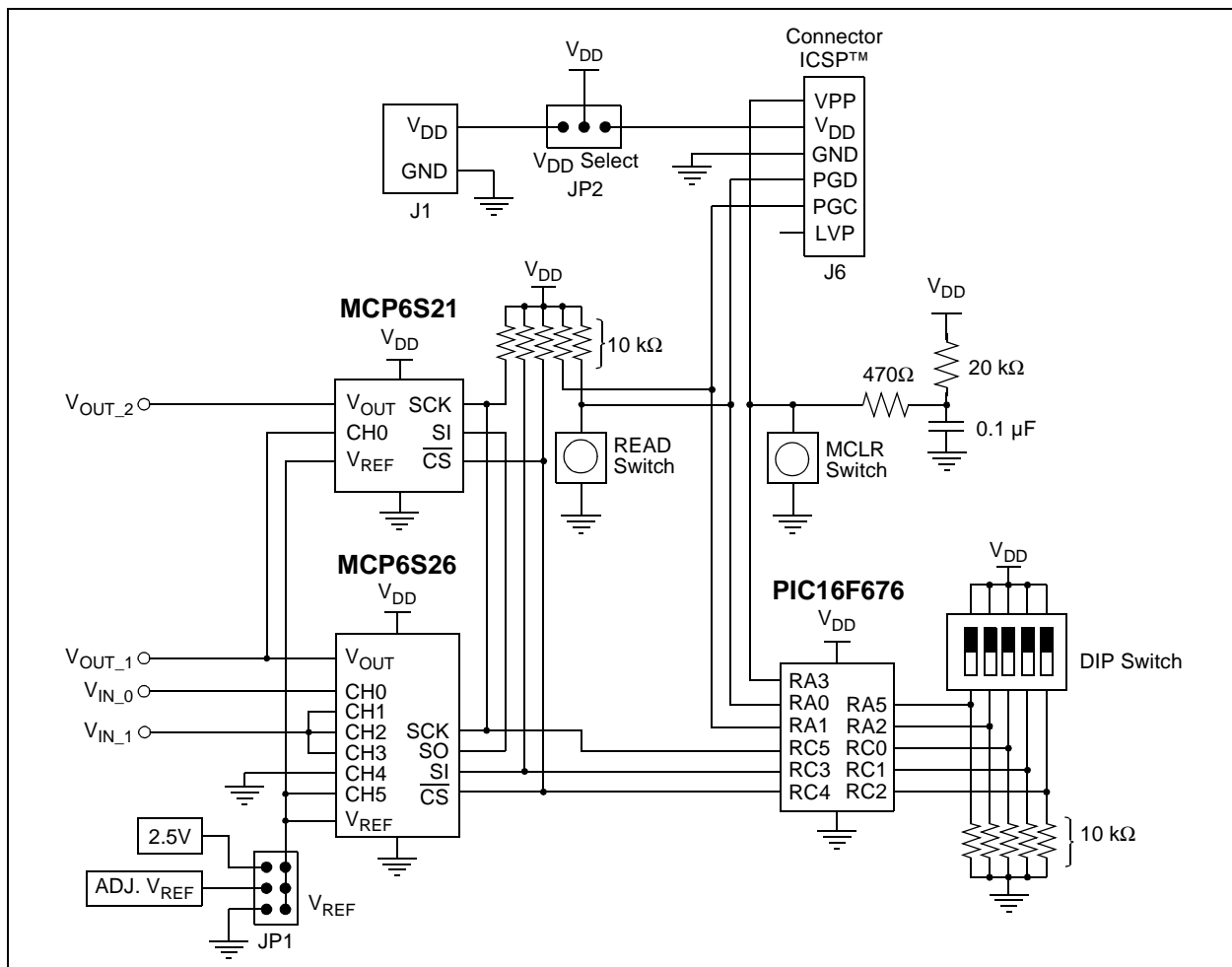

FIGURE 1-1: MCP6S2X Evaluation Board (Rev. 4) simplified schematic.

MCP6S2X Evaluation Board (Rev. 4) User's Guide

1.2 EVALUATION BOARD DESCRIPTION

The single-channel MCP6S21 and six-channel MCP6S26 have been selected for this evaluation board. The PIC16F676 microcontroller is used to program the PGAs according to the user inputs. User inputs are selected using the on-board DIP switch settings that are configured according to the table printed on the evaluation board. This allows the user to program the channel, gain and shutdown of each PGA. Either PGA or both PGAs can be shut down. The six channels of the MCP6S26 and the PGA gains of 1, 2, 4, 5, 8, 10, 16 and 32 V/V can be configured. Refer to **Appendix D."Setup Conditions"**, for additional information.

When the momentary **READ** push button switch is pressed, the microcontroller reads the DIP switch configuration through the I/O ports. The controller determines the proper command and data bytes to be transmitted to the PGAs and the transmits a 16 or 32-bit word through the Serial Peripheral Interface (SPI™) port.

When the momentary **MCLR** push button switch is pressed, the microcontroller Master Clear is activated. This resets the microcontroller to a known initial state.

The ICSP connector provides the capability of programming the PIC16F676 from a PC. This requires additional hardware, such as MPLAB® ICD 2.

The two PGAs are cascaded, while the signal output of the MCP6S26 is directly connected to the analog input of the MCP6S21. This configuration outputs a maximum signal gain of 1024 V/V.

The digital lines of the PGA are daisy chained. The MCP6S26 has a Serial-Out (SO) line that can be used to serially program another device. Therefore, the SO line is connected to the Serial-In (SI) line of the MCP6S21. If the MCP6S26 is removed from the socket, the MCP6S21 cannot be programmed.

The MCP6S2X family of PGAs has a reference voltage input pin to offset the output signal. There are three reference voltage options on the board: 2.5V, adjustable reference voltage (0V to 5V) and ground. These options can be selected using the on-board jumper (JP1).

A prototype area is available for user circuit interface. The inputs, outputs and reference voltage traces of the PGAs conveniently pass near the prototype area for ease of connection. Test point connectors are available to interface with external circuits. The signals V_{IN_0} , V_{IN_1} , V_{OUT_1} and V_{OUT_2} can use SMA connectors that slide horizontally onto the board. 50Ω termination resistors can be added to V_{IN_0} and V_{IN_1} . Refer to **Appendix A."Schematic and Board Layouts"** and **Appendix D."Setup Conditions"**, for additional information.

1.3 HOW IT IS USED

1.3.1 Application Procedure - Stand-Alone Mode

1. Apply a 2.5V to 5.5V supply voltage to the V_{DD} and ground (GND) terminals of J1. Place the V_{DD} SELECT jumper (JP2) at the bottom (nearest J1).

Note: If jumper JP2 is incorrectly placed, there may be a conflict between power supplies.

For additional information on powering-up the MCP6S2X Evaluation Board (Rev. 4), refer to **Section 1.4.2 “Applying Power”**. During power-up, the MCP6S2X PGA's default settings are Channel 0 (CH0) and gain = 1 V/V.

Note: Do **NOT** use the ICSP connector while in this mode (disconnect the cable). The results may be unpredictable and damage might occur due to conflicting voltage sources.

2. Connect a voltage-measuring device (such as an oscilloscope) to V_{OUT_1} for the MCP6S26 and/or V_{OUT_2} for the MCP6S21.
3. Select the desired reference voltage using JP1. If the adjustable reference voltage is selected, adjust this voltage using the potentiometer (ADJ_VREF). A test point is available to measure the reference voltage. Refer to **Section 1.4.5 “Reference Voltage”** for additional information.

Note: There are soldering pads available across each input terminal for termination resistors (R_4 and R_5). If these resistors (e.g., 50 Ω) are needed for your application, solder them across the pads.

4. Apply the input signal source at V_{IN_0} and/or V_{IN_1} . V_{IN_0} is connected to Channel 0 and V_{IN_1} is connected to Channel 1 of the MCP6S26 (refer to **Section 1.4.4 “Analog Interface”**). Make sure that the input signal range is at the proper level to avoid railing the amplifier output when the signal is gained. Refer to **Section 1.4.5 “Reference Voltage”** for additional information.
5. Refer to the Table 1-1 and select the desired gain, channel or shutdown using the on-board DIP switch. Press and release the **READ** push button switch to program the PGA and notice the change in the output voltage. Refer to **Section 1.4.6 “Programming The PGA”** for further explanation.

TABLE 1-1: DIP SWITCH CONFIGURATION TABLE

Register	MCP6S26 MSB → LSB	MCP6S21 MSB → LSB
Gain 1	00000	01000
Gain 2	00001	01001
Gain 4	00010	01010
Gain 5	00011	01011
Gain 8	00100	01100
Gain 10	00101	01101
Gain 16	00110	01110
Gain 32	00111	01111
Channel 0	10000	—
Channel 1	10001	—
Channel 2	10010	—
Channel 3	10011	—
Channel 4	10100	—
Channel 5	10101	—
SHDN	11000	—
SHDN	—	11001
SHDN	11010	11010

MCP6S2X Evaluation Board (Rev. 4) User's Guide

1.3.2 Application Procedure - Program Mode

1. Place the V_{DD} SELECT jumper (JP2) at the top (away from J1). The MPLAB ICD 2 will provide 5V to the PGAs and to the microcontroller. Disconnect any external power supply from J1.

Note: The ICSP™ connector can only be used to program the PIC16F676. In order to debug the firmware, use the MPLAB ICD 2 header. Refer to the MPLAB ICD 2 Header Installation Information (DS51292) for more information.

2. Configure the MPLAB ICD 2 to provide power to the evaluation board through the ICSP connector. This is accomplished by changing the MPLAB ICD 2 configuration in MPLAB IDE. The MPLAB ICD 2 needs to be powered by an external power source.
3. Connect the MPLAB ICD 2 to the ICSP connector and update the PIC16F676 firmware from a PC using MPLAB ICD 2.

Note: Do not change either of the manual push button switches (**MCLR** and **READ**) while debugging the firmware. The results of this action would be unpredictable, and may cause damage due to conflicting voltage sources.

4. Follow steps 3 thru 5 in 1.3.1 “Application Procedure - Stand-Alone Mode”.

1.4 HOW IT WORKS

1.4.1 PGA Functions

The PGA has an internal precision operational amplifier in a non-inverting configuration. The gain of this operational amplifier is set using resistive ladders in the feedback loop. The resistor ratio is set using analog switches that are configured according to the instructions stored in the memory registers.

The MCP6S21/2/6/8 family of PGAs provide various input channel options: one, two, six or eight channel inputs, respectively. The non-inverting input of the internal precision operational amplifier is directly connected to the input channels through a multiplexer. The multiplexer is also configured according to the command stored in the memory registers. Figure 1-2 shows a block diagram of the MCP6S26 with six input channels. For the single-channel MCP6S21, the non-inverting input is directly connected to the input pin without a multiplexer.

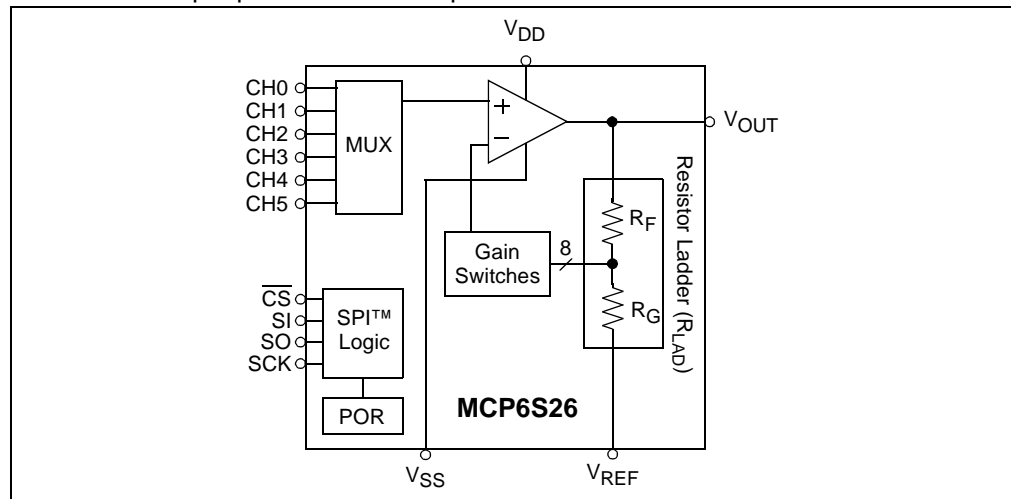

FIGURE 1-2: The six-channel MCP6S26 PGA Block Diagram. The single-channel MCP6S21 does not have an input multiplexer.

1.4.2 Applying Power

The V_{DD} SELECT jumper (JP2) connects the power plane (V_{DD}) to either an external power supply (through J1) or to MPLAB ICD 2 (via the ICSP connector (J6)). It selects between two modes of operation:

1. **Stand-Alone Mode** - The MCP6S2X Evaluation Board (Rev. 4) is configured using the on-board switches. Power is brought in to connector J1 from an external supply and the V_{DD} SELECT jumper selects J1. The external supply can be between 2.5V and 5.5V. When the PIC16F676 is in a valid operating voltage, the device will run the program stored in the device's program memory (the firmware).
2. **Program Mode** - The MCP6S2X Evaluation Board (Rev. 4) is connected to the MPLAB ICD 2, which is connected to a PC. Power is brought in via the ICSP connector and the V_{DD} SELECT jumper selects the ICSP source. V_{DD} is 5.0V. The PIC16F676 firmware is reprogrammed by MPLAB IDE (application on PC).

1.4.3 Digital Interface

The memory registers are programmed using the SPI™ interface from a PIC16F676 microcontroller. The digital interface uses a standard 3-wire SPI protocol with Chip Select (\overline{CS}), Serial Clock (SCK) and Serial In (SI) lines. These lines are directly connected to the MCP6S26 and have pull-up resistors. These pull-up resistors provide noise immunity for the PGA from the PICmicro® microcontroller's I/O pins. The two PGAs are daisy chained with the SO pin from the MCP6S26 and connected to the SI pin of the MCP6S21. The SCK and \overline{CS} lines are also connected to the MCP6S21.

In order to program the MCP6S21 through the daisy chain, the microcontroller pulls \overline{CS} low and sends the 32-bit word through the SPI line. The first 16-bit word contains the command and data bytes for the MCP6S21, while the next 16-bit word contains the command and data bytes for the MCP6S26. The second 16-bit word can be zeros or a NOP command. At the end of the 32nd clock cycle, the first 16-bit word is pushed out of the MCP6S26 (through the SO line) and into the MCP6S21 (through the SI line). When \overline{CS} toggles high, the bytes are latched in the registers. Instructions in the registers are then executed.

1.4.4 Analog Interface

The input channel 0 of the MCP6S26 is connected to V_{IN_0} . The input channels 1, 2 and 3 are connected to V_{IN_1} . Input channel 4 is connected to ground and input channel 5 is connected to the reference voltage. The user can connect two signal sources to channel 0 and channel 1 at V_{IN_0} and V_{IN_1} .

Note: There are soldering pads available across each input terminal for termination resistors (R_4 and R_5). If these resistors (e.g., 50 Ω) are needed for your application, solder them across the pads.

The output pin of the MCP6S26 is connected to V_{OUT_1} . This pin is also connected to Channel 0 of the MCP6S21. The MCP6S21 can be used to gain the signal from the MCP6S26 by gains of 1, 2, 4, 5, 8, 10, 16 and 32 V/V. If both PGAs are configured for a gain of 32 V/V, the total signal gain is 1024 V/V. This illustrates the fact that the user can cascade several PGAs to get higher gains. The output pin of the MCP6S21 is connected to V_{OUT_2} . The outputs of both PGAs are loaded with 10 k Ω resistors and 56 pF capacitors in parallel. These loads can be changed by the user.

Note: The signals V_{IN_0} , V_{IN_1} , V_{OUT_1} and V_{OUT_2} can be setup for test points (surface-mount on top) or for SMA connectors (slide onto board horizontally). Refer to **Appendix D, D.3 "SMA Connectors"** for more information.

MCP6S2X Evaluation Board (Rev. 4) User's Guide

1.4.5 Reference Voltage

The MCP6S2X Evaluation Board (Rev. 4) has three reference-voltage settings, as shown in Figure 1-3. The MCP1525, a precision reference voltage device, is used to provide a 2.5V reference. The minimum supply voltage for this device is 2.7V. Therefore, this device will not operate when the evaluation board supply voltage (V_{DD}) is below 2.7V. An adjustable reference voltage (0V to 5V) is also available using a mechanical potentiometer. Since the reference voltage input of the PGA requires a low-impedance source, these reference voltages are buffered using the MCP6022, a 10 MHz operational amplifier. The PGA reference voltage input can also be connected to ground. All of these options can be selected using the on-board jumper connector JP1 (refer to **Appendix D.** "Setup Conditions" and **D.5** "Reference Voltage Jumper Positions" for more information).

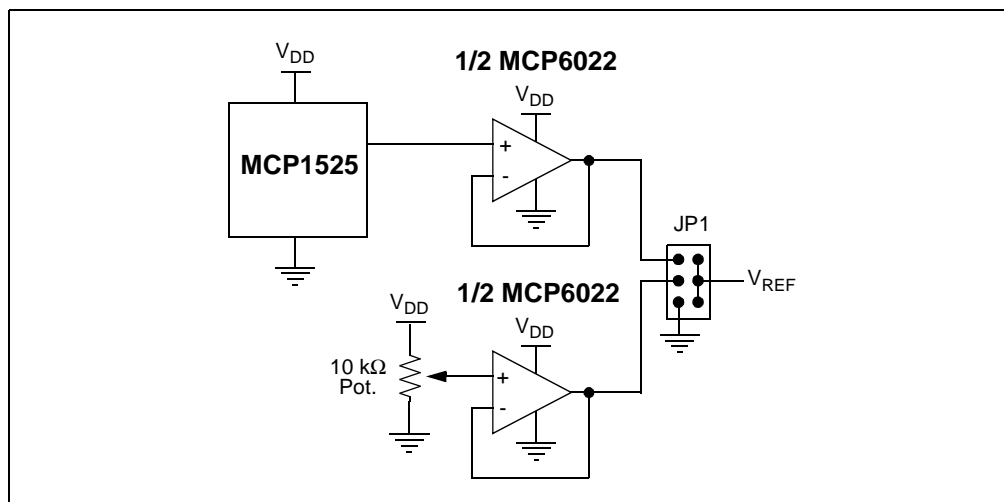

FIGURE 1-3: Simplified Reference Voltage Schematic.

The input and output of this PGA can swing rail-to-rail (V_{DD} and GND supply voltages). However, in order to keep linearity, the output voltage should not exceed the Maximum Output Voltage Swing, referred to in the electrical specifications of the MCP6S21/2/6/8 Data Sheet (DS21117). The reference voltage must be adjusted so that the maximum output would not exceed the specified limit.

The PGA output voltage, with respect to the input and reference voltages, can be determined using the following equation:

EQUATION 1-1:

$$V_{OUT_1} = G_{MCP6S26}(V_{IN_X} - V_{REF}) + V_{REF}$$

$$V_{OUT_2} = G_{MCP6S26} \times G_{MCP6S21}(V_{IN_X} - V_{REF}) + V_{REF}$$

Where: $G_{MCP6S26}$ = gain of 1, 2, 4, 5, 8, 10, 16 or 32 V/V
 $G_{MCP6S21}$ = gain of 1, 2, 4, 5, 8, 10, 16 or 32 V/V
 V_{IN_X} = signal at the MCP6S26's selected channel
 V_{REF} = Reference Voltage at V_{REF} pin.

1.4.6 Programming The PGA

The DIP switch lines are connected to the five microcontroller I/O lines (RA5, RA2, RC0, RC1 and RC2) with pull-down resistors (Refer to Figure 1-1 and **Appendix A. “Schematic and Board Layouts”**). The extreme top switch is the Most Significant Bit (MSB) and the extreme bottom switch is the Least Significant Bit (LSB). Pushing the switches right corresponds to the ‘1’, as shown on Table 1-1. Once the DIP switch is configured to the desired setting, the **READ** push-button switch must be pressed and released. When the button is released, the microcontroller reads the DIP switch settings and transmits the corresponding command and data bytes to the PGAs. The microcontroller remains in a loop to continuously monitor the **READ** push button switch. Refer to Table 1-1 for the settings.

MCP6S2X Evaluation Board (Rev. 4) User's Guide

NOTES:



MCP6S2X Evaluation Board (Rev. 4) User's Guide

Appendix A. Schematic and Board Layouts

A.1 INTRODUCTION

This appendix contains the schematic and printed circuit board (PCB) layout diagrams for the MCP6S2X Evaluation Board (Rev. 4).

A.1.1 Highlights

The MCP6S2X Evaluation Board (Rev. 4) is constructed using a four-layer PCB. The top and bottom layers are for components and traces. The second layer is the ground plane and the third layer is (V_{DD}) the power plane.

Diagrams included in this appendix include:

- Schematic
- Top Silk Screen Layer
- Top Metal Layer
- Ground Plane Layer
- Power Plane Layer
- Bottom Metal Layer
- Bottom Silk Screen Layer

Note: The bottom metal layer (A.7) is missing a connection between pin 8 of the PIC16F676 (U2 in A.2) and pin 6 of the DIP switch (DSW1 in A.2) and with the pull-down resistor (R11). These traces have been corrected prior to shipping by making a solder bridge between these pins.

MCP6S2X Evaluation Board (Rev. 4) User's Guide

A.2 SCHEMATIC

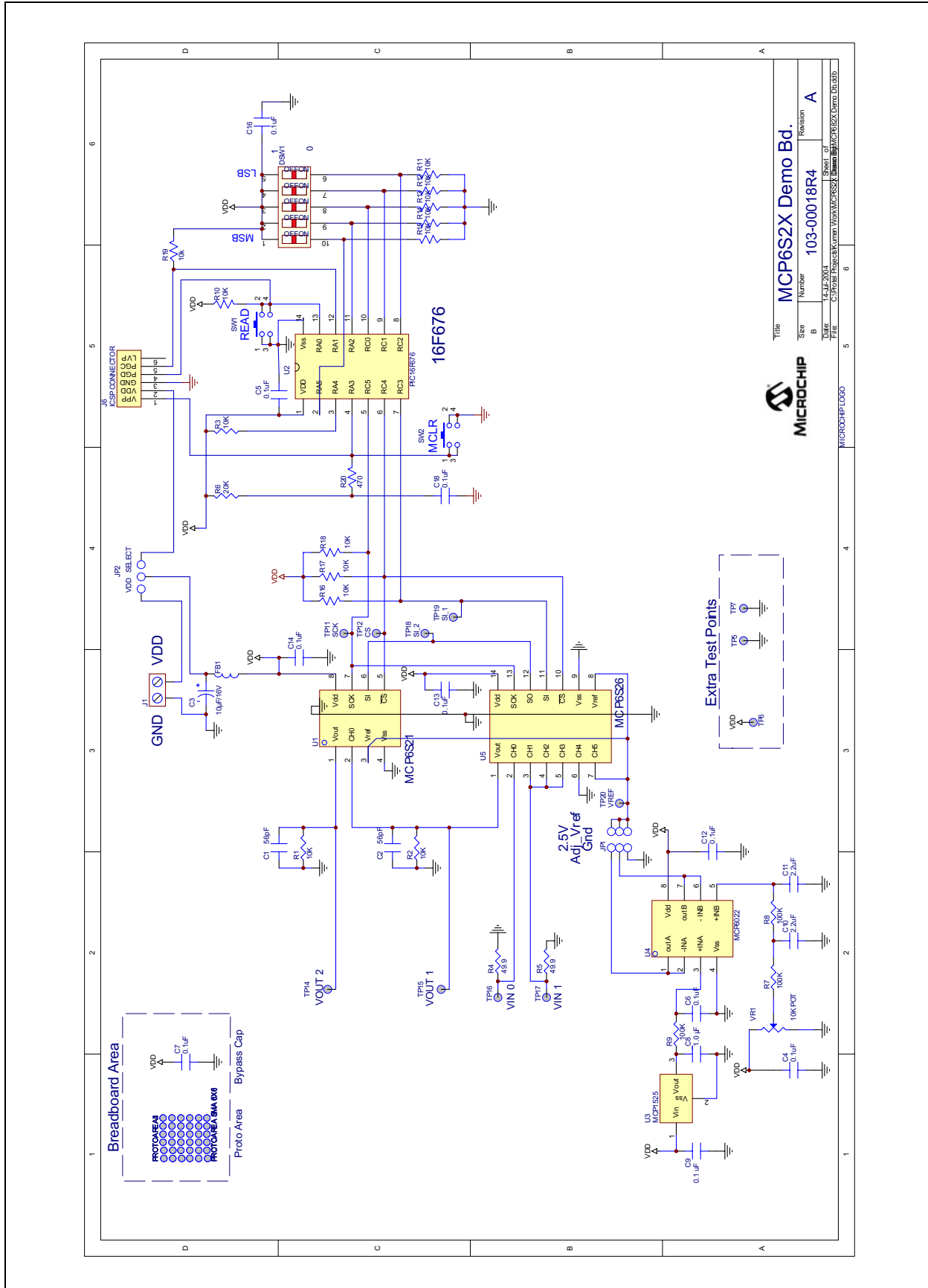

A.3 TOP SILK SCREEN

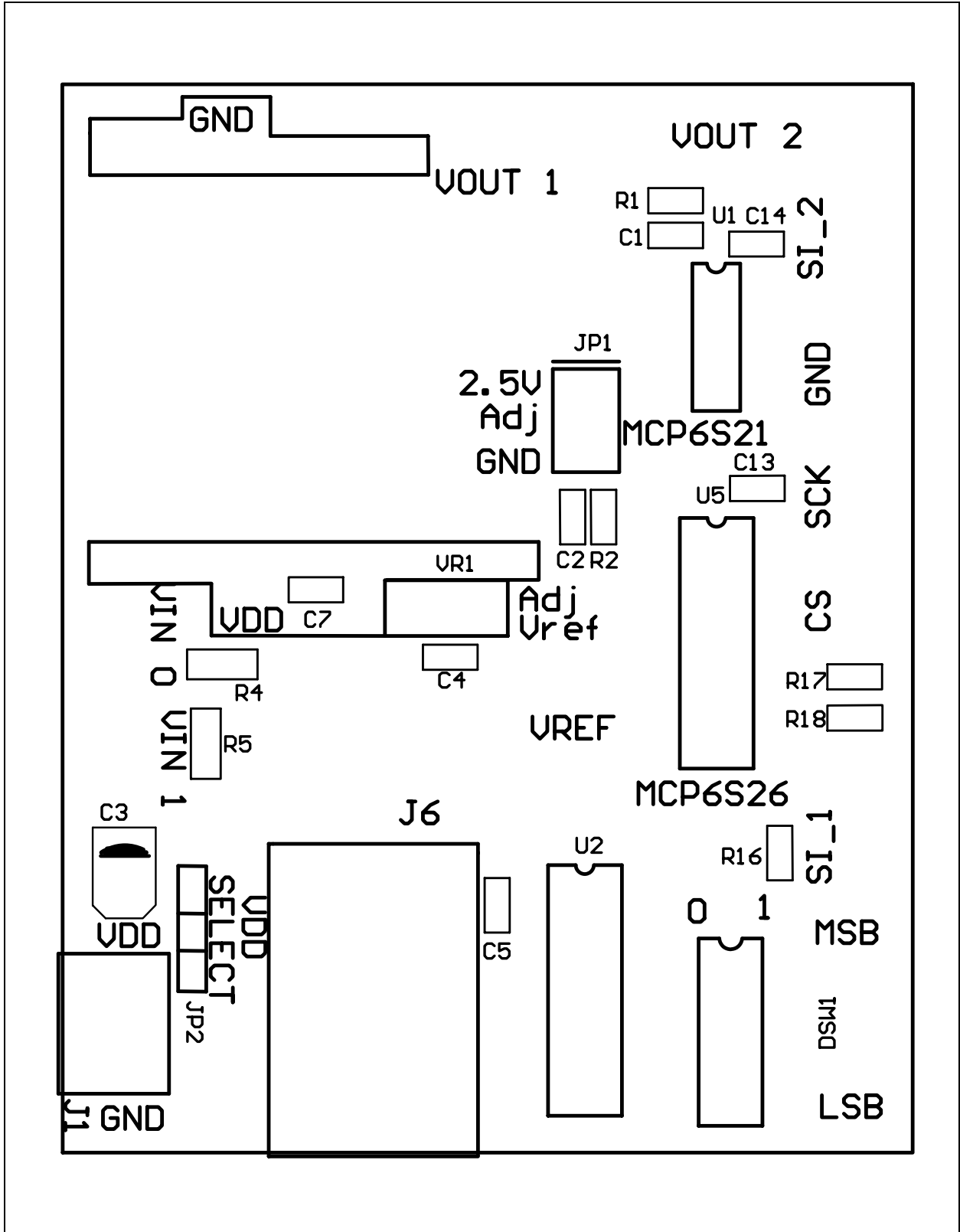

A.4 TOP METAL LAYER

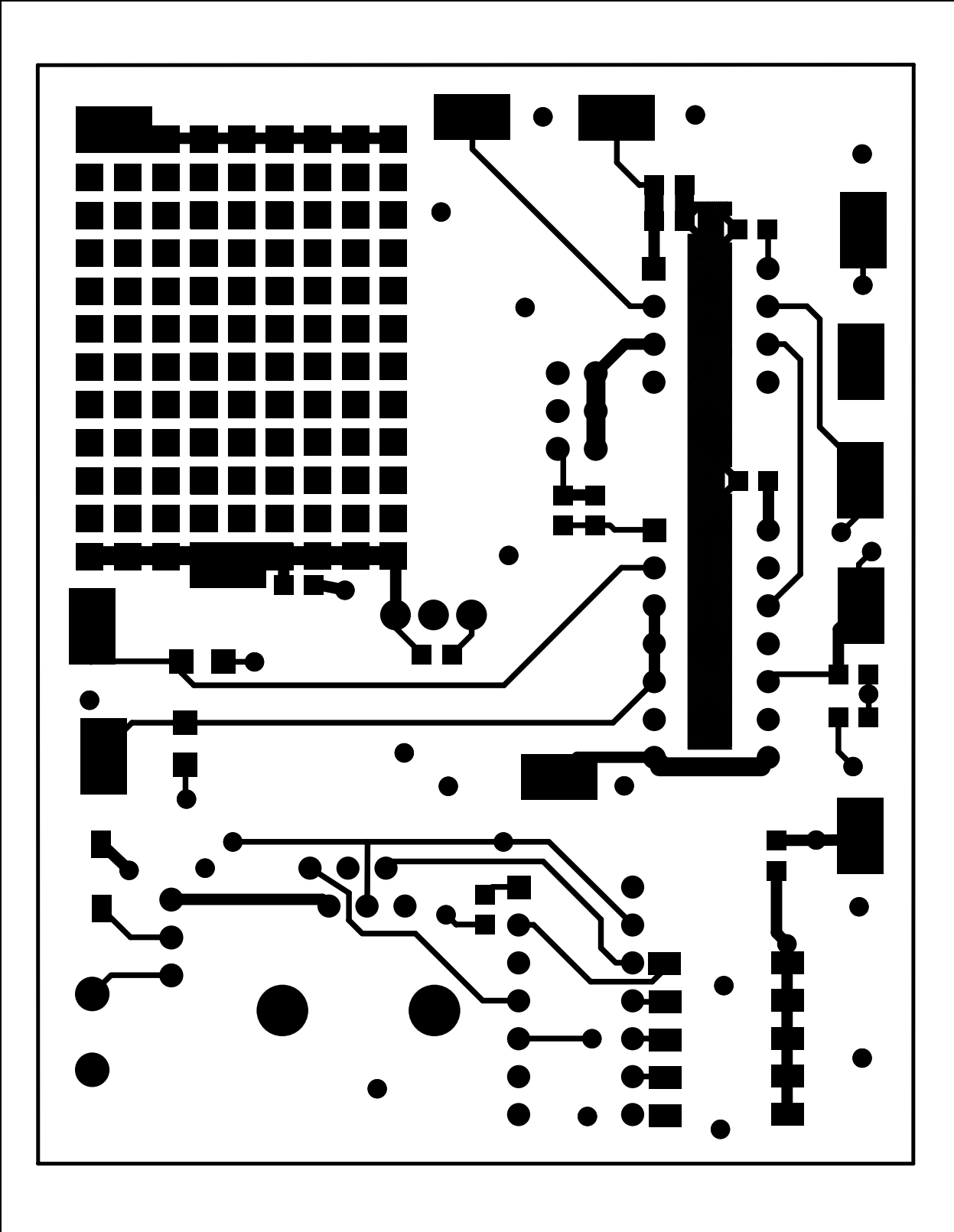

A.5 GROUND PLANE LAYER

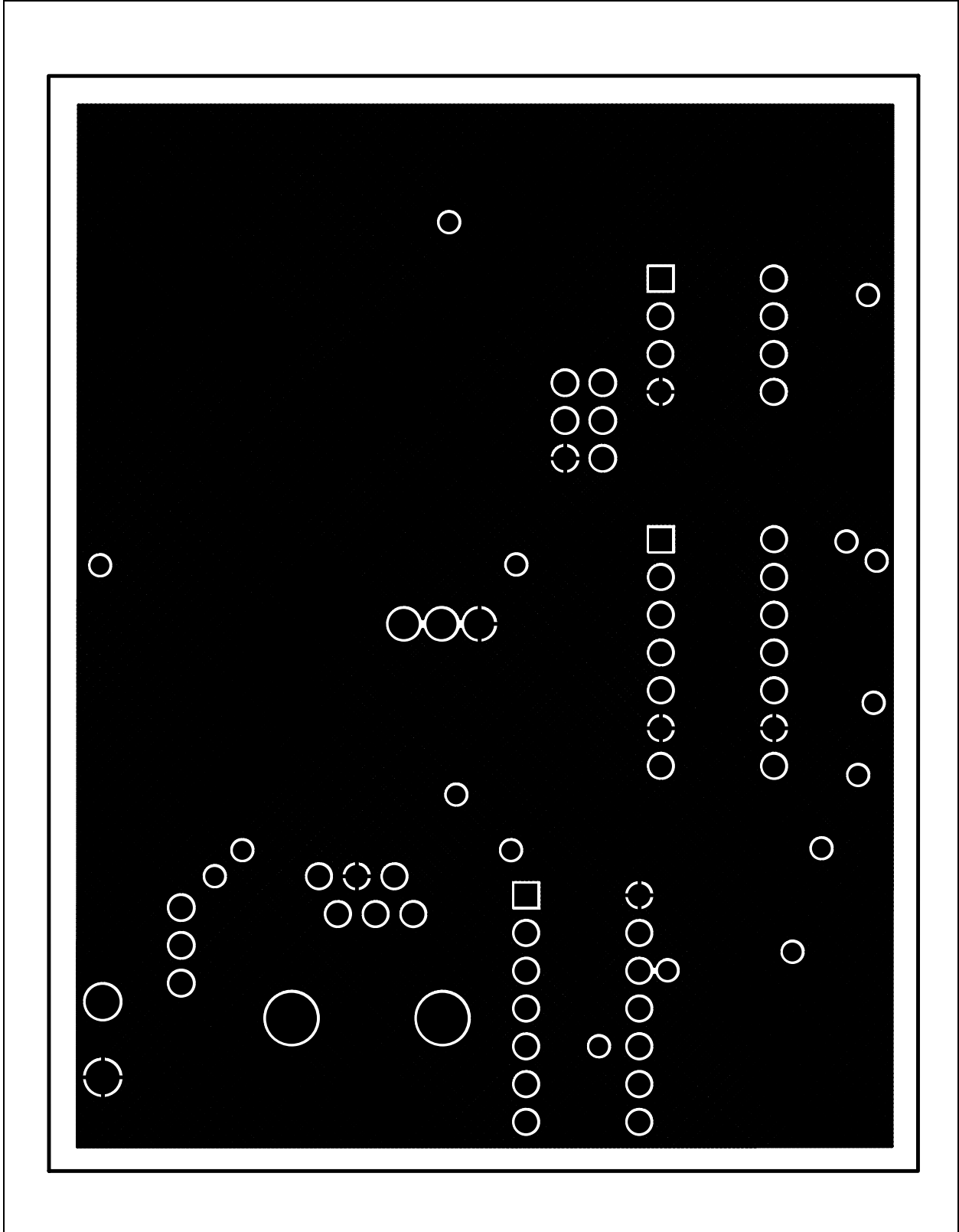

A.6 POWER PLANE LAYER

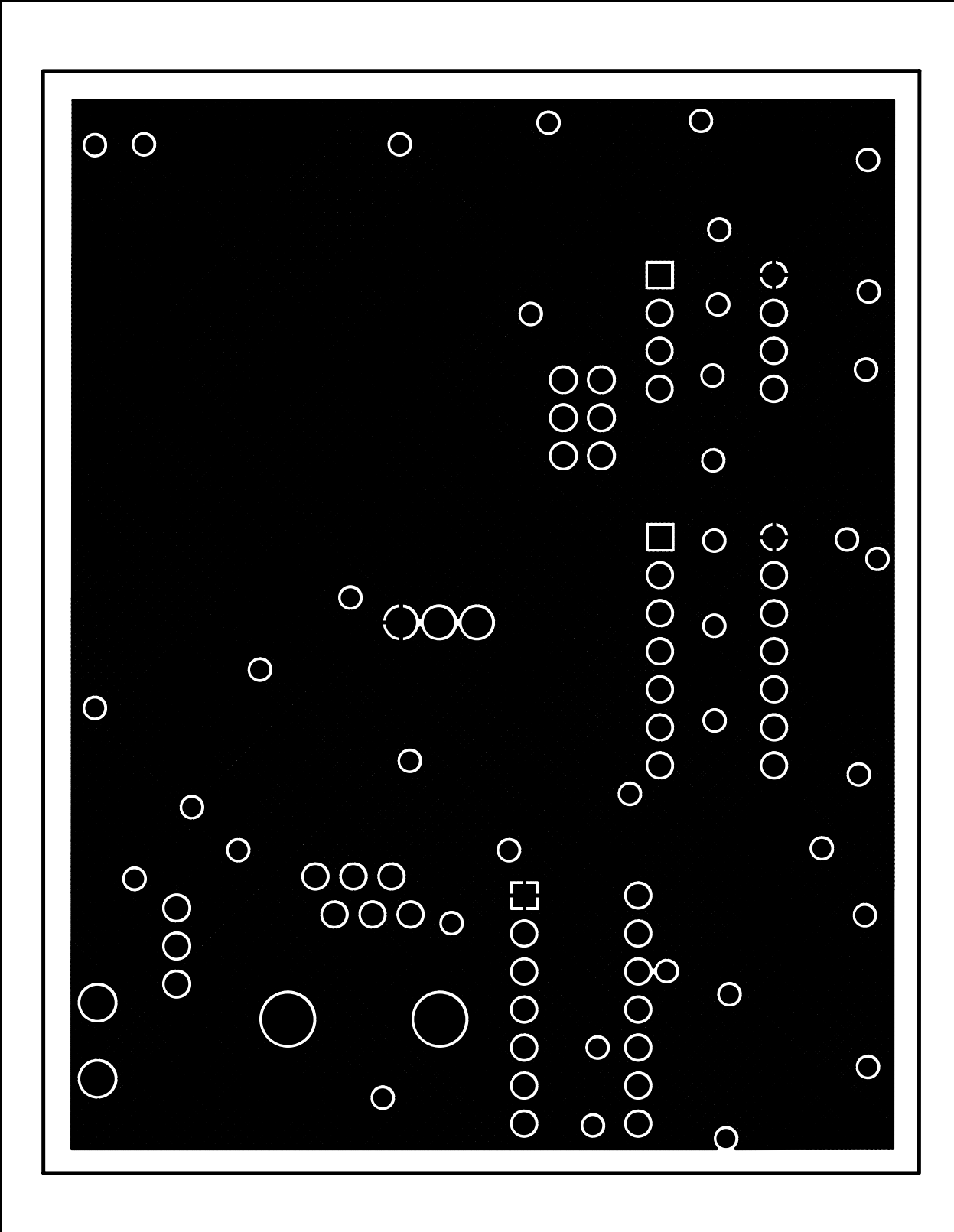

A.7 BOTTOM METAL LAYER

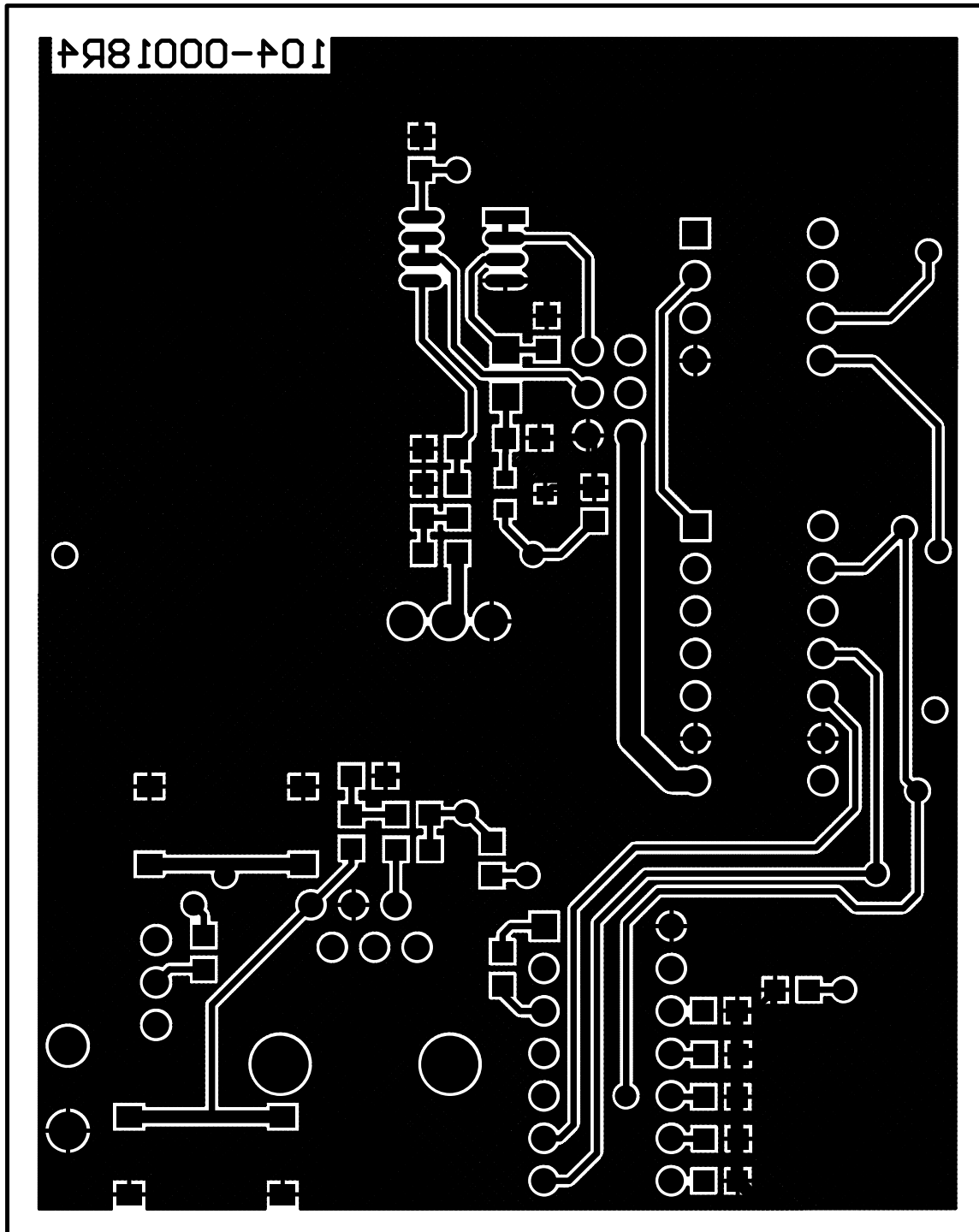

MCP6S2X Evaluation Board (Rev. 4) User's Guide

A.8 BOTTOM SILK SCREEN LAYER (TOP VIEW)

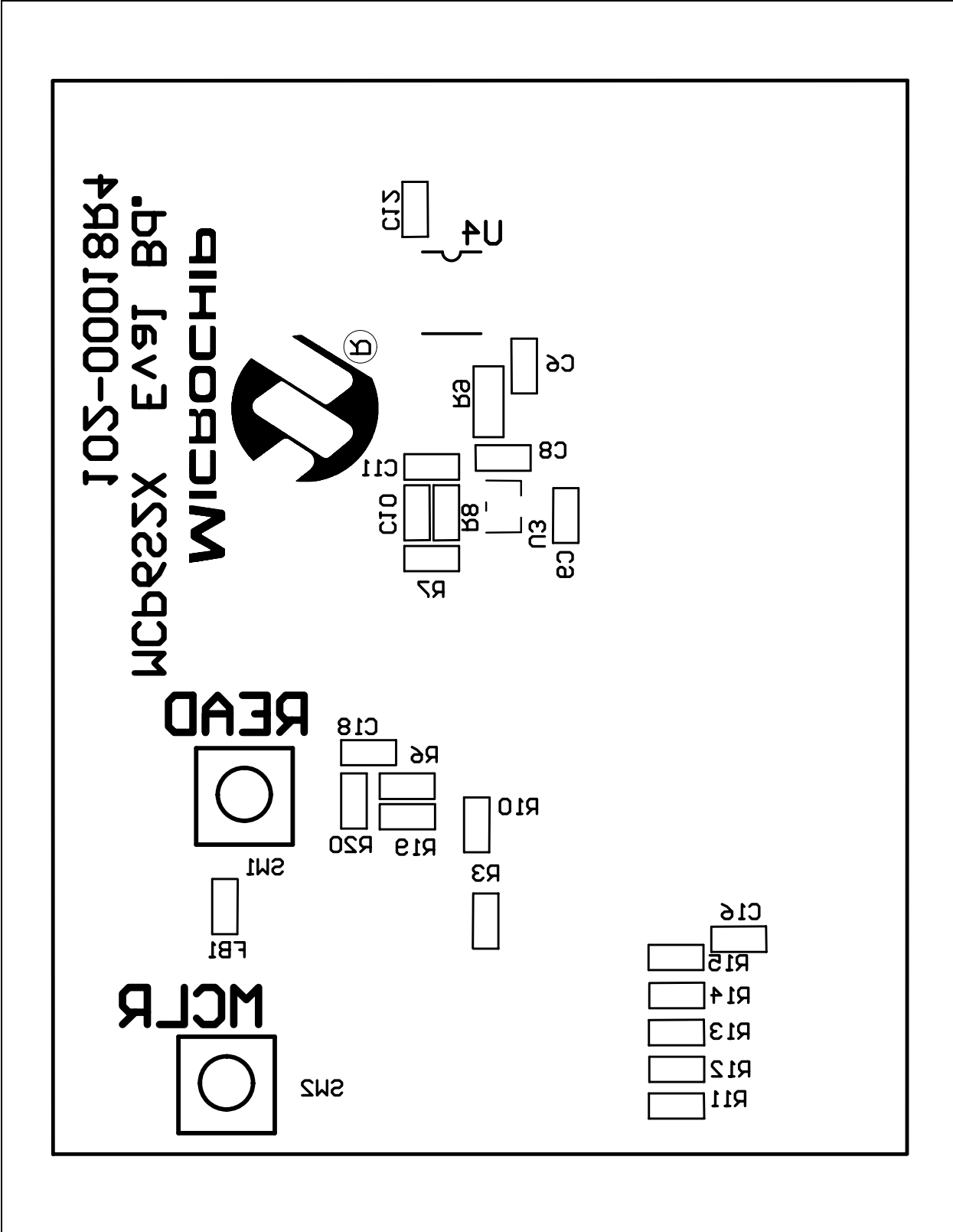



MCP6S2X Evaluation Board (Rev. 4) User's Guide

Appendix B. Bill of Materials (BOM)

B.1 INTRODUCTION

TABLE B-1: BILL OF MATERIALS

Reference Designator	Qty	Description	Manufacturer	Manufacturer Part Number
C1,C2	2	Capacitor, 56 pF, 0805	Digi-Key	PCC560CGCT
C3	1	Capacitor, 10 μF/16V, SMT	Jameco	192997
C4-C7,C9,C12-C14,C16,C18	10	Capacitor, 0.1 μF, 0805	Digi-Key	PCC1828CT-ND
C8	1	Capacitor, 1.0 μF, 0805	Digi-Key	PCC1849CT-ND
C10,C11	2	Capacitor, 2.2 μF, 0805	Digi-Key	PCC1851CT-ND
C15, C17		Note 4	—	—
DSW1	1	DIP Switch, DIP10	Digi-Key	CKN1289-ND
FB1	1	Ferrite Chip, 0805	Digi-Key	240-1018-1-ND
J1	1	2-pin Terminal Block, Connector	Digi-Key	ED1623-ND
J2-J5 (Note 1)	0	SMA Board Connectors, Female	Newark	SPC10611
J6	1	ICSP™ Connector, 6x6 Jack, R/A	Digi-Key	A9049-ND
JP1	1	Jumper, 3x2	Jameco	115035
JP2	1	Jumper, 1x3	Jameco	109575
	2	Shorting block for JP1, JP2	Jameco	152670
R1-R3,R10-R19	13	Resistor, 10 kΩ, 0805	Digi-Key	P10.0KCCT-ND
R4,R5 (Note 2)	2	Resistor, 49.9 Ω, 0805	Digi-Key	P49.9CCT-ND
R6	1	Resistor, 20 kΩ, 0805	Digi-Key	P20.0KCCT-ND
R7-R9	3	Resistor, 100 kΩ, 0805	Digi-Key	P100KCCT-ND
R20	1	Resistor, 470 Ω, 0805	Digi-Key	P475CCT-ND
SW1,SW2	2	Momentary push button switch	Digi-Key	SW400-ND
TP5-TP7, TP11, TP12, TP18-TP20	8	Testpoint, SMT	Digi-Key	5016K-ND
TP14-TP17 (Note 3)	4	Testpoint, SMT	Digi-Key	5016K-ND
TP1-TP4, TP8-TP10, TP13		Note 4	—	—
U1	1	MCP6S21, PDIP-8	Microchip Technology Inc.	MCP6S21
U2	1	PIC16F676, PDIP-14	Microchip Technology Inc.	PIC16F676
U3	1	MCP1525, SOT23-3	Microchip Technology Inc.	MCP1525
U4	1	MCP6022, SOIC-8	Microchip Technology Inc.	MC6022
U5	1	MCP6S26, PDIP-14	Microchip Technology Inc.	MCP6S26
VR1	1	10 kΩ Potentiometer	Digi-Key	3296W-103-ND
	1	8-pin DIP socket (for U1)	Jameco	51625
	2	14-pin DIP socket (for U2, U5)	Jameco	37196

Note 1: Optional; supplied by customer (use J2-J5 or TP14-TP17).

Note 2: Optional; in kit of parts.

Note 3: Optional; in kit of parts (use J2-J5 or TP14-TP17).

Note 4: These capacitors and test points do not exist on the board; they are gaps in the numbering sequence.

MCP6S2X Evaluation Board (Rev. 4) User's Guide

NOTES:



MCP6S2X Evaluation Board (Rev. 4) User's Guide

Appendix C. Evaluation Board Firmware

Software License Agreement

This software is supplied herewith by Microchip Technology Incorporated (the "Company") is supplied to you, the Company's customer, for use solely and exclusively on Microchip's products manufactured by the Company.

This software is owned by the Company and/or its supplier, and is protected under applicable copyright laws. All rights are reserved. Any use in violation of the foregoing restrictions may subject the user to criminal sanctions under applicable laws, as well as to civil liability for the breach of the terms and conditions of this license.

THE SOFTWARE IS PROVIDED IN AN "AS IS" CONDITION. NO WARRANTIES, WHETHER EXPRESS, IMPLIED OR STATUTORY, INCLUDING, BUT NOT LIMITED TO, IMPLIED WARRANTIES OF MERCHANTABILITY AND FITNESS FOR A PARTICULAR PURPOSE APPLY TO THIS SOFTWARE. THE COMPANY SHALL NOT, IN ANY CIRCUMSTANCES, BE LIABLE FOR SPECIAL, INCIDENTAL OR CONSEQUENTIAL DAMAGES, FOR ANY REASON WHATSOEVER.

```
-----  
; This firmware is developed for the MCP6S2X PGA demo board.  
;  
; The firmware reads the user interface dip and push-button switch  
; settings and programs the PGA accordingly.  
;  
;  
; File name:      pga_demo.asm  
; Date:          08/09/04  
; File Version:  1.00  
;  
; Programmer:    MPLAB ICE 2  
; File Required: PIC16F676.inc  
;  
; Demo Board:  
;   Name:        MCP6S2X Eval. Bd.  
;   Number:      102-00018R4  
;   Rev.:        R4  
;   PGAs:        MCP6S21 (or MCP6S91), MCP6S26  
;  
; Author:        Ezana Haile  
; Company:       Microchip Technology, Inc.  
-----  
  
ERRORLEVEL -302  
ERRORLEVEL -305  
  
#INCLUDE <P16F676.INC>  
  
__CONFIG      _MCLRE_ON & _WDT_OFF & _INTRC_OSC_NOCLKOUT & _PWRTE_OFF & _BODEN_OFF &  
_CPD_OFF  
  
; definitions  
  
#DEFINE CS      PORTC, 4      ; CHIP SELECT  
#DEFINE SCK     PORTC, 5      ; CLOCK  
#DEFINE DO      PORTC, 3      ; DATA OUT  
#DEFINE PUSH    PORTA, 0      ; READ PUSH BUTTON  
#DEFINE SW1     PORTC, 2      ; SWITCH 1  
#DEFINE SW2     PORTC, 1      ; SWITCH 2  
#DEFINE SW3     PORTC, 0      ; SWITCH 3  
#DEFINE SW4     PORTA, 2      ; SWITCH 4  
#DEFINE SW5     PORTA, 5      ; SWITCH 5  
#DEFINE PRG_GAIN B'01000000' ; PROGRAM GAIN  
#DEFINE PRG_CHANNEL B'01000001' ; PROGRAM CHANNEL  
#DEFINE PGA_SHDN B'00100000' ; SHUTDOWN PGA
```

MCP6S2X Evaluation Board (Rev. 4) User's Guide

```
; reserve memory byte

        CBLOCK 0X20
            COUNTER, BUFFER
        ENDC

;=====
;===== PROGRAM =====
;=====

PGA_DEMO                ; CODE NAME
    ORG    0X00
    GOTO   START

START ORG    0X05

    BCF    STATUS, RP0    ; BANK 0
    MOVLW  H'07'
    MOVWF  CMCON          ; DIGITAL I/O
    BSF    STATUS, RP0    ; BANK 1
    CLRF   ANSEL          ; DIGITAL I/O
    CLRF   WPUA
    MOVLW  H'3F'
    MOVWF  TRISA          ; SET PORT A AS INPUT
    MOVLW  H'07'          ; SET RC<5,4,3> OUTPUT AND RC<2,1,0> INPUT
    MOVWF  TRISC          ; SET PORT C AS INPUT
    BCF    STATUS, RP0    ; BANK 0

READ  BTFSC  PUSH        ; CHECK TO SEE IF THE READ BUTTON IS PRESSED
      GOTO  READ
RDING BTFSS  PUSH        ; WAIT UNTIL THE BUTTON IS RELEASED
      GOTO  RDING

      BSF    CS          ; UNSELECT THE DEVICES
      BCF    DO          ; KEEP THE DATAOUT (DO) LOW
      BCF    SCK         ; SET CLOCK
      CLRF   BUFFER      ; CLEAR BUFFER

      BTFSC  SW5
      GOTO  CHANNEL_SHDN ; DETERMINE IF IT'S FOR CHANNEL OR
                        ; SHUTDOWN OTHERWISE PROGRAM GAIN

; PROGRAM THE GAIN OF PGA 1 (MCP6S26) OR PGA 2 (MCP6S21)

      BTFSC  SW4
      GOTO  PGA_2_GAIN   ; DETERMINE THE DEVICE

PGA_1_GAIN
    BCF    CS          ; SELECT PGA
    MOVLW  PRG_GAIN    ; PROGRAM GAIN CONFIGURATION
    MOVWF  BUFFER
    CALL   BITBANG     ; SEND IT THROUGH SPI
    CALL   READ_SWITCH ; READ SWITCH SETTINGS
    CALL   BITBANG     ; SEND IT THROUGH SPI AND PROGRAM PGA
    BSF    CS          ; UNSELECT THE DEVICES
    GOTO  READ

PGA_2_GAIN
    BCF    CS          ; SELECT PGA
    MOVLW  PRG_GAIN    ; PROGRAM GAIN CONFIGURATION
    MOVWF  BUFFER
    CALL   BITBANG     ; SEND IT THROUGH SPI AND PROGRAM PGA
    CALL   READ_SWITCH ; READ SWITCH SETTINGS
    CALL   BITBANG     ; SEND IT THROUGH SPI
    CLRF   BUFFER      ; SEND ZEROS TO PUSH OUT THE DATA TO PGA 2
    CALL   BITBANG     ; SEND 8 DUMMY BITS
    CALL   BITBANG     ; SEND 8 DUMMY BITS
    BSF    CS          ; UNSELECT THE DEVICES
    GOTO  READ

; PROGRAM THE CHANNEL OR SHUTDOWN PGA 1 (MCP6S26) OR PGA 2 (MCP6S21)

CHANNEL_SHDN
    BTFSC  SW4
    GOTO  SHDN        ; GOTO SHUTDOWN

CHANNEL
    BCF    CS          ; SELECT PGA
    MOVLW  PRG_CHANNEL ; PROGRAM CHANNEL CONFIGURATION
    MOVWF  BUFFER
    CALL   BITBANG     ; SEND IT THROUGH SPI
    CALL   READ_SWITCH ; READ SWITCH SETTINGS
    CALL   BITBANG     ; SEND IT THROUGH SPI AND PROGRAM PGA
```

```

BSF CS ; UNSELECT THE DEVICES
GOTO READ

SHDN
BTFSC SW3 ; IF THE 3RD SWITCH IS HIGH THEN DON'T SHUTDOWN
GOTO READ

BTFSC SW2 ; DETERMINE WHICH DEVICE
GOTO SHDN_BOTH ; SHUTDOWN BOTH PGAS
BTFSC SW1
GOTO SHDN_PGA_2 ; IF THE 1RD SWITCH IS HIGH THEN DON'T SHUTDOWN

SHDN_PGA_1 ; SHUTDOWN THE FIRST PGA
BCF CS ; SELECT PGA
MOVLW PGA_SHDN ; PROGRAM SHUTDOWN CONFIGURATION
MOVWF BUFFER
CALL BITBANG ; SEND IT THROUGH SPI AND PROGRAM PGA
CALL BITBANG ; SEND 8 DUMMY BITS
BSF CS ; UNSELECT THE DEVICES
GOTO READ

SHDN_PGA_2 ; SHUTDOWN THE SECOND PGA
BCF CS ; SELECT PGA
MOVLW PGA_SHDN ; PROGRAM SHUTDOWN CONFIGURATION
MOVWF BUFFER
CALL BITBANG ; SEND IT THROUGH SPI AND PROGRAM PGA
CALL BITBANG ; SEND 8 DUMMY BITS
CLRF BUFFER
CALL BITBANG ; SEND 8 DUMMY BITS
CALL BITBANG ; SEND 8 DUMMY BITS
BSF CS ; UNSELECT THE DEVICES
GOTO READ

SHDN_BOTH ; SHUTDOWN BOTH PGAS
BCF CS ; SELECT PGA
MOVLW PGA_SHDN ; PROGRAM SHUTDOWN CONFIGURATION
MOVWF BUFFER
CALL BITBANG ; SEND IT THRU SPI AND SHUTDOWN PGA
CALL BITBANG ; SEND 8 DUMMY BITS
CALL BITBANG ; SEND IT THRU SPI AND SHUTDOWN PGA
CALL BITBANG ; SEND 8 DUMMY BITS
BSF CS ; UNSELECT THE DEVICES
GOTO READ

;-----
;--- READ THE SWITCH SETTINGS
;-----

READ_SWITCH
CLRF BUFFER ; PROGRAM BUFFER FROM SWITCHES
BTFSC SW3 ; CHECK THE 3RD SWITCH
BSF BUFFER, 2
BTFSC SW2 ; CHECK THE 2RD SWITCH
BSF BUFFER, 1
BTFSC SW1 ; CHECK THE 1RD SWITCH
BSF BUFFER, 0
RETURN

;-----
;--- BIT BANG SPI COMMUNICATION
;-----

BITBANG
CLRC
MOVLW H'08'
MOVWF COUNTER ; SET THE BIT BANG COUNTER
SEND BTFSC BUFFER, 7 ; SEE THE LAST BIT OF THE BUFFER
BSF DO ; THE SWITCH IS SET, THEN SET THE BUFFER HIGH
BSF SCK ; SET CLOCK
BCF SCK ; CLEAR CLOCK
BCF DO ; CLEAR THE DATA
RLF BUFFER,F ; ROLL THE BITS
DECFSZ COUNTER, F ; CHECK END OF COUNTER
GOTO SEND ; LOOP
RETURN

;-----
END

```

MCP6S2X Evaluation Board (Rev. 4) User's Guide

NOTES:



MCP6S2X Evaluation Board (Rev. 4) User's Guide

Appendix D. Setup Conditions

D.1 DIP SWITCH CONFIGURATIONS (STAND-ALONE MODE)

TABLE D-1: DIP SWITCH CONFIGURATION FOR MCP6S21 ONLY

Register	MCP6S21 MSB → LSB
Gain 1	01000
Gain 2	01001
Gain 4	01010
Gain 5	01011
Gain 8	01100
Gain 10	01101
Gain 16	01110
Gain 32	01111
SHDN (Shutdown)	11001

TABLE D-2: DIP SWITCH CONFIGURATION FOR MCP6S26 ONLY

Register	MCP6S26 MSB → LSB
Gain 1	00000
Gain 2	00001
Gain 4	00010
Gain 5	00011
Gain 8	00100
Gain 10	00101
Gain 16	00110
Gain 32	00111
Channel 0	10000
Channel 1	10001
Channel 2	10010
Channel 3	10011
Channel 4	10100
Channel 5	10101
SHDN (Shutdown)	11000

TABLE D-3: DIP SWITCH CONFIGURATION FOR MCP6S21 AND MCP6S26

Register	MCP6S21/MCP6S26 MSB → LSB
SHDN (Shutdown)	11010

MCP6S2X Evaluation Board (Rev. 4) User's Guide

D.2 MOMENTARY PUSH BUTTON SWITCH

D.2.1 Read Function

To change the PGA settings:

1. **Stand-alone Mode** - Configure the DIP Switch according to the tables in **Appendix D.1**. Press and release the **READ** switch; the microcontroller immediately updates the PGA's configuration.
2. **Program Mode** - The change in PGA configuration needs to be provided in customer-supplied firmware.

D.2.2 Master Clear Function

To re-initialize the microcontroller:

1. **Stand-alone Mode** - Press and release the **MCLR** switch.
2. **Program Mode** - Do not use the **MCLR** switch. Disconnect from MPLAB ICD 2 and reconnect.

D.3 SMA CONNECTORS

The illustration below shows how the SMA connectors are slid onto the board at test points V_{IN_0} , V_{IN_1} , V_{OUT_1} , and V_{OUT_2} . The round center conductor goes over the test pad and two of the square lugs go underneath the board on the unmasked ground fill (bottom metal). Solder the lugs and center conductor to the board.

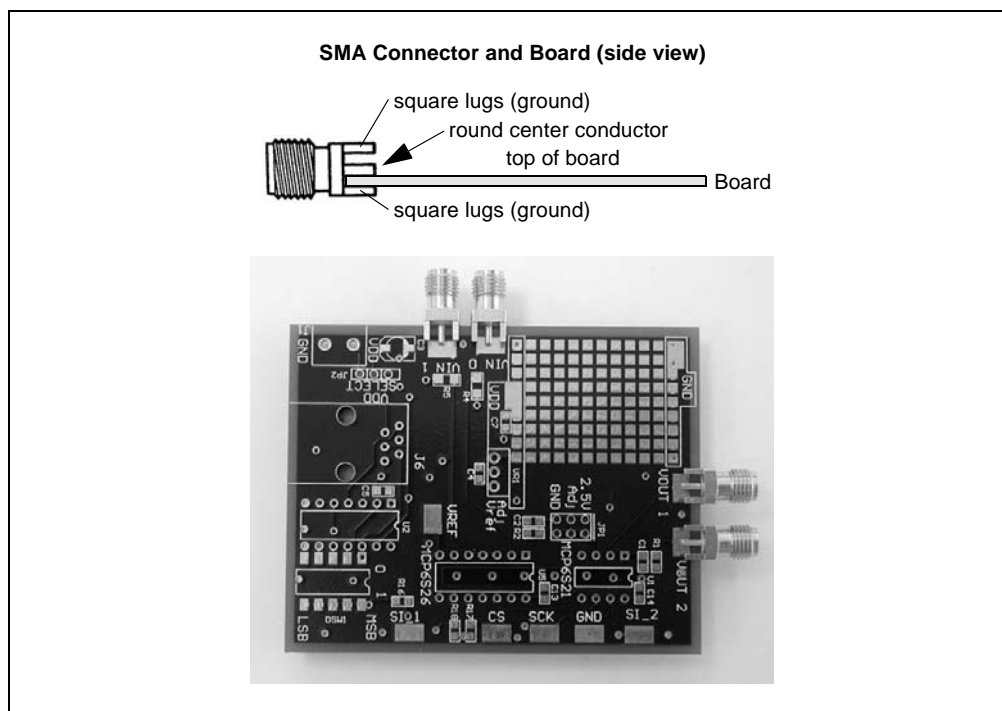

FIGURE D-1: SMA Connectors.

D.4 TEST POINTS

TABLE D-4: TEST POINT CONNECTORS

Name	Reference Designator	Description
V_{IN_0}	TP16	Input Voltage to Channel 0 (MCP6S26)
V_{IN_1}	TP17	Input Voltage to Channel 1 (MCP6S26)
V_{OUT_1}	TP15	Output Voltage from MCP6S26 (Input Voltage to MCP6S21)
V_{OUT_2}	TP14	Output Voltage from MCP6S21
V_{REF}	TP20	Reference Voltage (for MCP6S26 and MCP6S21)
V_{DD}	TP6	Positive Supply Voltage
GND	TP5, TP7	Ground (Negative Supply Voltage)
\overline{CS}	TP12	SPI™ Chip Select
SCK	TP11	SPI Serial Clock
SI_1	TP19	SPI Serial Data In (MCP6S26)
SI_2	TP18	SPI Serial Data In (MCP6S21); SPI Serial Data Out (MCP6S26)

D.5 REFERENCE VOLTAGE JUMPER POSITIONS

TABLE D-5: JUMPER POSITIONS

Jumper	Position	Function
JP1	Top	2.5V
	Middle	Adjustable Reference Voltage
	Bottom	Ground
JP2	Top	V_{DD} supplied by ICSP™ Connector J6
	Bottom	V_{DD} supplied by Terminal Block J1



WORLDWIDE SALES AND SERVICE

AMERICAS

Corporate Office
2355 West Chandler Blvd.
Chandler, AZ 85224-6199
Tel: 480-792-7200
Fax: 480-792-7277
Technical Support:
480-792-7627
Web Address:
www.microchip.com

Atlanta
Alpharetta, GA
Tel: 770-640-0034
Fax: 770-640-0307

Boston
Westford, MA
Tel: 978-692-3848
Fax: 978-692-3821

Chicago
Itasca, IL
Tel: 630-285-0071
Fax: 630-285-0075

Dallas
Addison, TX
Tel: 972-818-7423
Fax: 972-818-2924

Detroit
Farmington Hills, MI
Tel: 248-538-2250
Fax: 248-538-2260

Kokomo
Kokomo, IN
Tel: 765-864-8360
Fax: 765-864-8387

Los Angeles
Mission Viejo, CA
Tel: 949-462-9523
Fax: 949-462-9608

San Jose
Mountain View, CA
Tel: 650-215-1444
Fax: 650-961-0286

Toronto
Mississauga, Ontario,
Canada
Tel: 905-673-0699
Fax: 905-673-6509

ASIA/PACIFIC

Australia - Sydney
Tel: 61-2-9868-6733
Fax: 61-2-9868-6755

China - Beijing
Tel: 86-10-8528-2100
Fax: 86-10-8528-2104

China - Chengdu
Tel: 86-28-8676-6200
Fax: 86-28-8676-6599

China - Fuzhou
Tel: 86-591-750-3506
Fax: 86-591-750-3521

China - Hong Kong SAR
Tel: 852-2401-1200
Fax: 852-2401-3431

China - Shanghai
Tel: 86-21-6275-5700
Fax: 86-21-6275-5060

China - Shenzhen
Tel: 86-755-8290-1380
Fax: 86-755-8295-1393

China - Shunde
Tel: 86-757-2839-5507
Fax: 86-757-2839-5571

China - Qingdao
Tel: 86-532-502-7355
Fax: 86-532-502-7205

ASIA/PACIFIC

India - Bangalore
Tel: 91-80-2229-0061
Fax: 91-80-2229-0062

India - New Delhi
Tel: 91-11-5160-8632
Fax: 91-11-5160-8632

Japan - Kanagawa
Tel: 81-45-471- 6166
Fax: 81-45-471-6122

Korea - Seoul
Tel: 82-2-554-7200
Fax: 82-2-558-5932 or
82-2-558-5934

Singapore
Tel: 65-6334-8870
Fax: 65-6334-8850

Taiwan - Kaohsiung
Tel: 886-7-536-4816
Fax: 886-7-536-4817

Taiwan - Taipei
Tel: 886-2-2500-6610
Fax: 886-2-2508-0102

Taiwan - Hsinchu
Tel: 886-3-572-9526
Fax: 886-3-572-6459

EUROPE

Austria - Weis
Tel: 43-7242-2244-399
Fax: 43-7242-2244-393

Denmark - Ballerup
Tel: 45-4420-9895
Fax: 45-4420-9910

France - Massy
Tel: 33-1-69-53-63-20
Fax: 33-1-69-30-90-79

Germany - Ismaning
Tel: 49-89-627-144-0
Fax: 49-89-627-144-44

Italy - Milan
Tel: 39-0331-742611
Fax: 39-0331-466781

Netherlands - Drunen
Tel: 31-416-690399
Fax: 31-416-690340

England - Berkshire
Tel: 44-118-921-5869
Fax: 44-118-921-5820

08/24/04

Компания «Life Electronics» занимается поставками электронных компонентов импортного и отечественного производства от производителей и со складов крупных дистрибьюторов Европы, Америки и Азии.

С конца 2013 года компания активно расширяет линейку поставок компонентов по направлению коаксиальный кабель, кварцевые генераторы и конденсаторы (керамические, пленочные, электролитические), за счёт заключения дистрибьюторских договоров

Мы предлагаем:

- Конкуренеспособные цены и скидки постоянным клиентам.
- Специальные условия для постоянных клиентов.
- Подбор аналогов.
- Поставку компонентов в любых объемах, удовлетворяющих вашим потребностям.
- Приемлемые сроки поставки, возможна ускоренная поставка.
- Доставку товара в любую точку России и стран СНГ.
- Комплексную поставку.
- Работу по проектам и поставку образцов.
- Формирование склада под заказчика.
- Сертификаты соответствия на поставляемую продукцию (по желанию клиента).
- Тестирование поставляемой продукции.
- Поставку компонентов, требующих военную и космическую приемку.
- Входной контроль качества.
- Наличие сертификата ISO.

В составе нашей компании организован Конструкторский отдел, призванный помогать разработчикам, и инженерам.

Конструкторский отдел помогает осуществить:

- Регистрацию проекта у производителя компонентов.
- Техническую поддержку проекта.
- Защиту от снятия компонента с производства.
- Оценку стоимости проекта по компонентам.
- Изготовление тестовой платы монтаж и пусконаладочные работы.



Тел: +7 (812) 336 43 04 (многоканальный)

Email: org@lifeelectronics.ru