



ON Semiconductor®

<http://onsemi.com>

LA6581DM

Monolithic Linear IC

Fan Motor Driver

BLT Driver Single-Phase Full-Wave

Overview

The LA6581DM is a low-saturation BTL output linear driving motor driver for single-phase bipolar fan motors. It features quite, low power, high efficiency drive that suppresses reactive current. It is optimal for use in applications that require miniaturization and low noise, such as CPU cooling fan motors and 5 to 12V electronic game products.

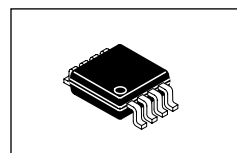

Micro8

Functions

- Single-phase full-wave linear drive with BTL output (gain resistance 500Ω to 284kΩ, 55dB) : Suitable for the equipment requiring silent operation, such as game equipment, CPU cooler, etc. because of its freedom from switching noise.
- Low-voltage operation possible, with wide operable voltage range (2.2 to 16V)
- Low saturation output (Upper + lower saturation voltage : V_{Osat} (total) = 0.3V typ, $I_O = 100mA$) : High coil efficiency with low current drain. IC itself does not generate much heat.
- High impedance of Hall input pin
- FG output (rotation speed detection output : open collector output)
- Heat protection circuit : When the large current flows because of output short-circuit, raising the IC chip temperature above 180°C, the heat protection circuit suppresses the drive current, preventing IC burn and breakdown.
- Extra-small package (Micro8)
Small substrate while allowing larger blades

Specifications

Maximum Ratings at $T_a = 25^\circ C$

Parameter	Symbol	Conditions	Ratings	Unit
Output voltage	V_{CC} max		18	V
Allowable power dissipation	P_d max	Mounted on a specified board *1	400	mW
Output current	I_{OUT1} max	*2	0.36	A
	I_{OUT2} max	T<200ms	0.50	A
Output withstand voltage	V_{OUT} max		18	V
FG output withstand	V_{FG} max		18	V
FG output current	I_{FG} max		5	mA
Operating temperature	T_{opr}		-30 to +100	°C
Storage temperature	T_{stg}		-55 to +150	°C

*1: Mounted on a board (20.0mm 10.0mm 0.8mm: Paper Phenol, wiring density 20%)

*2: This specifies the starting current. $T_j=15^\circ C$ max must not be exceeded..

Caution 1) Absolute maximum ratings represent the value which cannot be exceeded for any length of time.

Caution 2) Even when the device is used within the range of absolute maximum ratings, as a result of continuous usage under high temperature, high current, high voltage, or drastic temperature change, the reliability of the IC may be degraded. Please contact us for the further details.

Stresses exceeding Maximum Ratings may damage the device. Maximum Ratings are stress ratings only. Functional operation above the Recommended Operating Conditions is not implied. Extended exposure to stresses above the Recommended Operating Conditions may affect device reliability.

ORDERING INFORMATION

See detailed ordering and shipping information on page 5 of this data sheet.

LA6581DM

Recommended Operating Conditions at Ta = 25°C

Parameter	Symbol	Conditions	Ratings	Unit
Supply voltage	V _{CC}		2.2 to 16	V
Common-phase input voltage range of Hall input	V _{ICM}		0.3 to V _{CC} -1.5	V

Electrical Characteristics at Ta = 25°C, V_{CC} = 12.0V, unless especially specified.

Parameter	Symbol	Conditions	Ratings			Unit
			min	Typ	Max	
Circuit Current	I _{CC}	IN ⁻ = 5.8V, IN ⁺ = 6.0V, R _L = ∞		14	19	mA
OUT output low voltage	V _{OL}	I _O = 100mA		0.1	0.2	V
OUT output high voltage	V _{OH}	I _O = 100mA		0.1	0.2	V
Hall bias voltage	V _{HB}	RH = 360Ω +91Ω	1.85	1.95	2.05	V
Hall amplifier gain	V _g		52	55	58	dB
Hall amplifier input current	V _{INR}		-10	-2	+10	μA
FG output low voltage	V _{FG}	I _{FG} = 3mA		0.2	0.3	V
FG output leakage current	I _{FGL}	V _{FG} = 7V			30	μA
Thermal protection circuit	Th	* Design guarantee	150	180	200	°C

*: These values are design guarantee values, and are not tested.

Truth Table

IN ⁻	IN ⁺	OUT1	OUT2	FG	mode
H	L	H	L	L	During rotation
L	H	L	H	Off	
-	-	Off	Off	-	During overheat protection

Pd-Ta

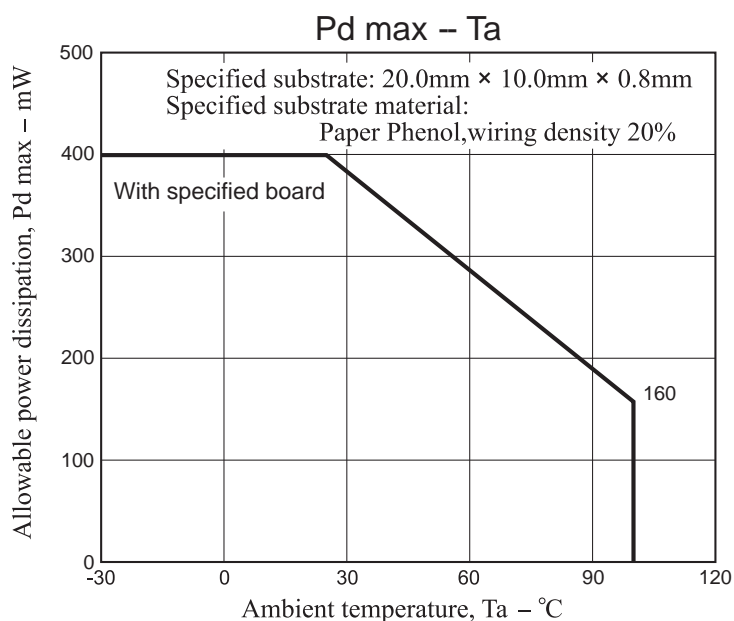

Package Dimensions

unit : mm (typ)

Micro8

CASE 846A-02

ISSUE J

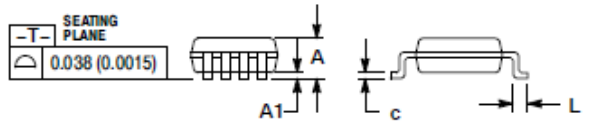
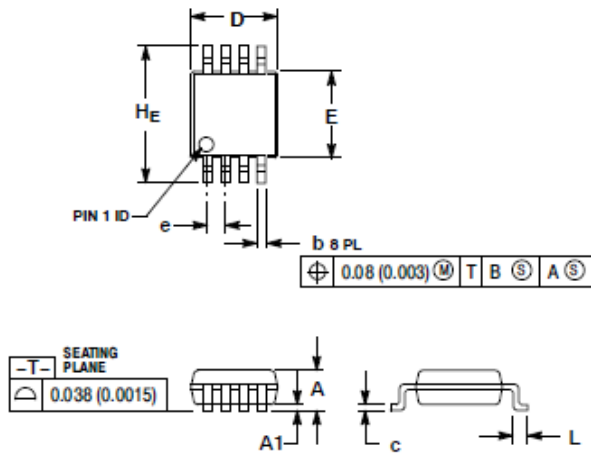

RECOMMENDED SOLDERING FOOTPRINT*

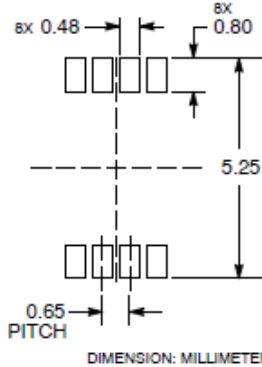

*For additional information on our Pb-Free strategy and soldering details, please download the ON Semiconductor Soldering and Mounting Techniques Reference Manual, SOLDERRM/D.

NOTES:

1. DIMENSIONING AND TOLERANCING PER ANSI Y14.5M, 1982.
2. CONTROLLING DIMENSION: MILLIMETER.
3. DIMENSION A DOES NOT INCLUDE MOLD FLASH, PROTRUSIONS OR GATE BURRS. MOLD FLASH, PROTRUSIONS OR GATE BURRS SHALL NOT EXCEED 0.15 (0.008) PER SIDE.
4. DIMENSION B DOES NOT INCLUDE INTERLEAD FLASH OR PROTRUSION. INTERLEAD FLASH OR PROTRUSION SHALL NOT EXCEED 0.25 (0.010) PER SIDE.
5. 846A-01 OBSOLETE, NEW STANDARD 846A-02.

DIM	MILLIMETERS			INCHES		
	MIN	NOM	MAX	MIN	NOM	MAX
A	--	--	1.10	--	--	0.043
A1	0.05	0.08	0.15	0.002	0.003	0.008
b	0.25	0.33	0.40	0.010	0.013	0.018
e	0.13	0.18	0.23	0.005	0.007	0.009
D	2.90	3.00	3.10	0.114	0.118	0.122
E	2.90	3.00	3.10	0.114	0.118	0.122
e	0.65 BSC			0.026 BSC		
L	0.40	0.56	0.70	0.016	0.021	0.028
Hc	4.75	4.90	5.05	0.187	0.193	0.199

GENERIC MARKING DIAGRAM*

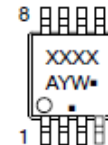

- XXXX = Specific Device Code
 - A = Assembly Location
 - Y = Year
 - W = Work Week
 - = Pb-Free Package
- (Note: Microdot may be in either location)

*This information is generic. Please refer to device data sheet for actual part marking. Pb-Free indicator, "G" or microdot "•", may or may not be present.

STYLE 1:	STYLE 2:	STYLE 3:
PIN 1. SOURCE	PIN 1. SOURCE 1	PIN 1. N-SOURCE
2. SOURCE	2. GATE 1	2. N-GATE
3. SOURCE	3. SOURCE 2	3. P-SOURCE
4. GATE 2	4. GATE 2	4. P-GATE
5. DRAIN	5. DRAIN 2	5. P-DRAIN
6. DRAIN	6. DRAIN 2	6. P-DRAIN
7. DRAIN	7. DRAIN 1	7. N-DRAIN
8. DRAIN	8. DRAIN 1	8. N-DRAIN

Pin Assignment

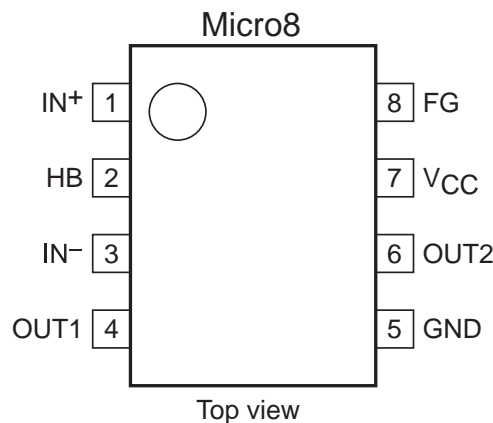

Block Diagram

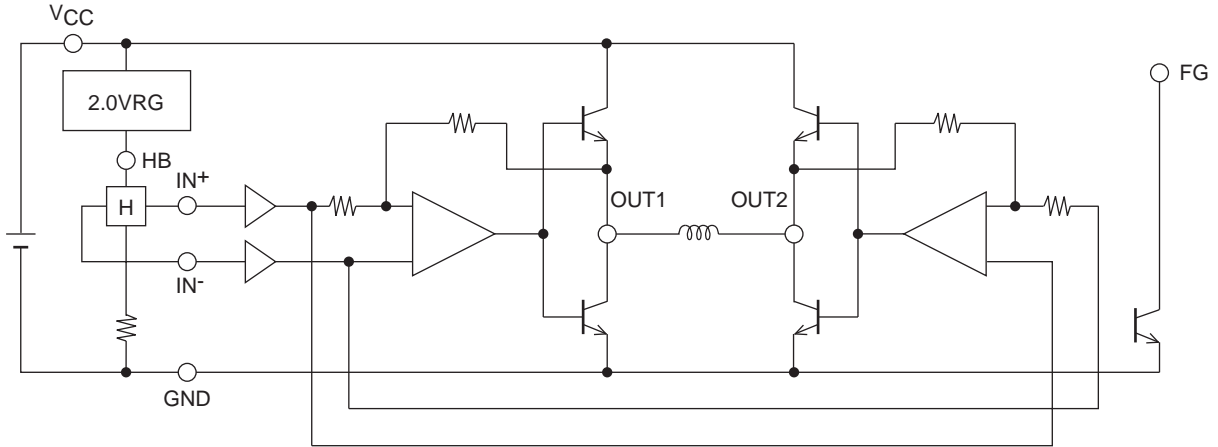

Timing Chart

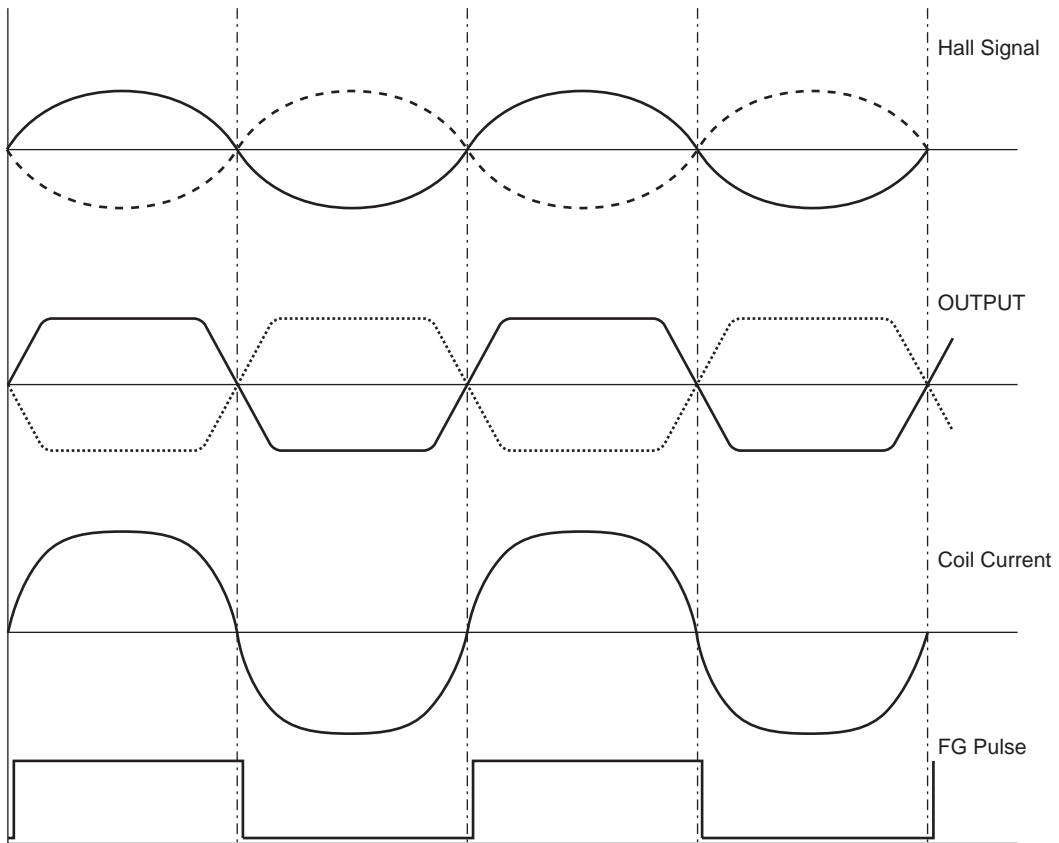

Application Circuit Example

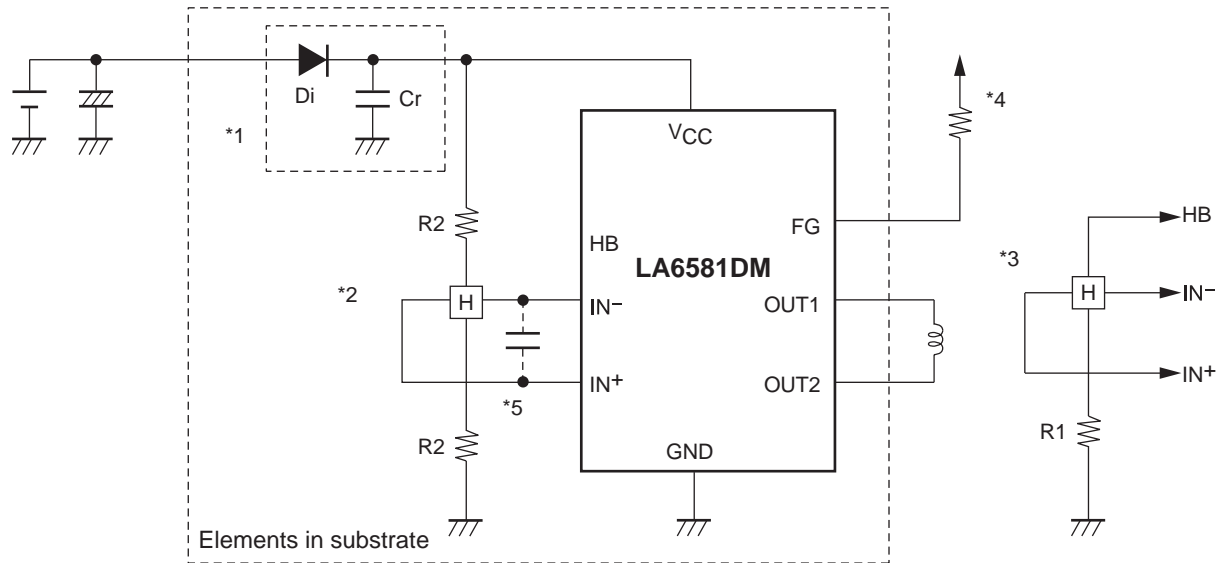

- *1 : When Di to prevent breakdown in case of reverse connection is used, it is necessary to insert a capacitor Cr to secure the regenerative current route. Similarly, Cr is necessary to enhance the reliability when there is no capacitor near the fan power line.
- *2 : To obtain Hall bias from VCC, carry out $1/2 \times V_{CC}$ bias as shown in the figure. Linear driving is made through voltage control of the coil by amplifying the Hall output. When the Hall element output is large, the startup performance and efficiency are improved. Adjustment of the Hall element can reduce the noise further.
- *3 : When the Hall bias is taken from the HB pin, constant-voltage bias is made with about 2.0V. Therefore, the Hall element can provide the output satisfactory in temperature characteristics. Adjustment of the Hall output amplitude is made with R1. (When $V_{CC} = 12V$, the step *2 above proves advantageous for IC heat generation.)
- *4 : Keep this open when not used.
- *5 : When the wiring from the Hall output to IC Hall input is long, noise may be carried through the wiring. In this case, insert the capacitor as shown in the figure.

ORDERING INFORMATION

Device	Package	Shipping (Qty / Packing)
LA6581DMR2G	Micro8 (Pb-Free / Halogen Free)	4000 / Tape & Reel

ON Semiconductor and the ON logo are registered trademarks of Semiconductor Components Industries, LLC (SCILLC). SCILLC owns the rights to a number of patents, trademarks, copyrights, trade secrets, and other intellectual property. A listing of SCILLC's product/patent coverage may be accessed at www.onsemi.com/site/pdf/Patent-Marking.pdf. SCILLC reserves the right to make changes without further notice to any products herein. SCILLC makes no warranty, representation or guarantee regarding the suitability of its products for any particular purpose, nor does SCILLC assume any liability arising out of the application or use of any product or circuit, and specifically disclaims any and all liability, including without limitation special, consequential or incidental damages. "Typical" parameters which may be provided in SCILLC data sheets and/or specifications can and do vary in different applications and actual performance may vary over time. All operating parameters, including "Typicals" must be validated for each customer application by customer's technical experts. SCILLC does not convey any license under its patent rights nor the rights of others. SCILLC products are not designed, intended, or authorized for use as components in systems intended for surgical implant into the body, or other applications intended to support or sustain life, or for any other application in which the failure of the SCILLC product could create a situation where personal injury or death may occur. Should Buyer purchase or use SCILLC products for any such unintended or unauthorized application, Buyer shall indemnify and hold SCILLC and its officers, employees, subsidiaries, affiliates, and distributors harmless against all claims, costs, damages, and expenses, and reasonable attorney fees arising out of, directly or indirectly, any claim of personal injury or death associated with such unintended or unauthorized use, even if such claim alleges that SCILLC was negligent regarding the design or manufacture of the part. SCILLC is an Equal Opportunity/Affirmative Action Employer. This literature is subject to all applicable copyright laws and is not for resale in any manner.

Компания «Life Electronics» занимается поставками электронных компонентов импортного и отечественного производства от производителей и со складов крупных дистрибьюторов Европы, Америки и Азии.

С конца 2013 года компания активно расширяет линейку поставок компонентов по направлению коаксиальный кабель, кварцевые генераторы и конденсаторы (керамические, пленочные, электролитические), за счёт заключения дистрибьюторских договоров

Мы предлагаем:

- Конкурентоспособные цены и скидки постоянным клиентам.
- Специальные условия для постоянных клиентов.
- Подбор аналогов.
- Поставку компонентов в любых объемах, удовлетворяющих вашим потребностям.
- Приемлемые сроки поставки, возможна ускоренная поставка.
- Доставку товара в любую точку России и стран СНГ.
- Комплексную поставку.
- Работу по проектам и поставку образцов.
- Формирование склада под заказчика.
- Сертификаты соответствия на поставляемую продукцию (по желанию клиента).
- Тестирование поставляемой продукции.
- Поставку компонентов, требующих военную и космическую приемку.
- Входной контроль качества.
- Наличие сертификата ISO.

В составе нашей компании организован Конструкторский отдел, призванный помогать разработчикам, и инженерам.

Конструкторский отдел помогает осуществить:

- Регистрацию проекта у производителя компонентов.
- Техническую поддержку проекта.
- Защиту от снятия компонента с производства.
- Оценку стоимости проекта по компонентам.
- Изготовление тестовой платы монтаж и пусконаладочные работы.



Тел: +7 (812) 336 43 04 (многоканальный)

Email: org@lifeelectronics.ru