

Evaluation Board for the **AD8174** 250 MHz, 10 ns Switching Multiplexer with Amplifier

FEATURES

Full-featured evaluation board for the **AD8174**
±5 V operation

EVALUATION KIT CONTENTS

AD8174-EB evaluation board

EQUIPMENT NEEDED

Signal source or video pattern generator and signal analyzer
Power supplies (+2 V/1 A and ±5 V/1 A)
SMA to BNC cables for inputs, outputs, and other pins

GENERAL DESCRIPTION

The **AD8174** is a high speed buffered multiplexer that offers an internal current feedback output amplifier whose gain is programmed via external resistors and is capable of delivering 50 mA of output current. The **AD8174** offers -3 dB signal bandwidth of 250 MHz and a slew rate greater than 1000 V/μs. The **AD8174** has excellent video specifications with low differential gain of 0.02%, low differential phase error of 0.05°, and 0.1 dB flatness out to 85 MHz. With a low -78 dB at 5 MHz of crosstalk and better than -88 dB at 5 MHz isolation, the **AD8174** is useful in many high speed applications. It is also a low power device consuming only 9.7 mA from a ±5 V supply.

The **AD8174** offers a high speed disable feature that allows the user to put the output into a high impedance state for cascading stages so that the off channels do not load the output bus. In addition, the **AD8174** can be shut down when not in use to minimize power consumption ($I_s = 1.5$ mA). The **AD8174** is available in 14-lead PDIP and 14-lead SOIC packages.

Full details about the device are available in the **AD8174** data sheet, which should be consulted when using the **AD8174-EB**.

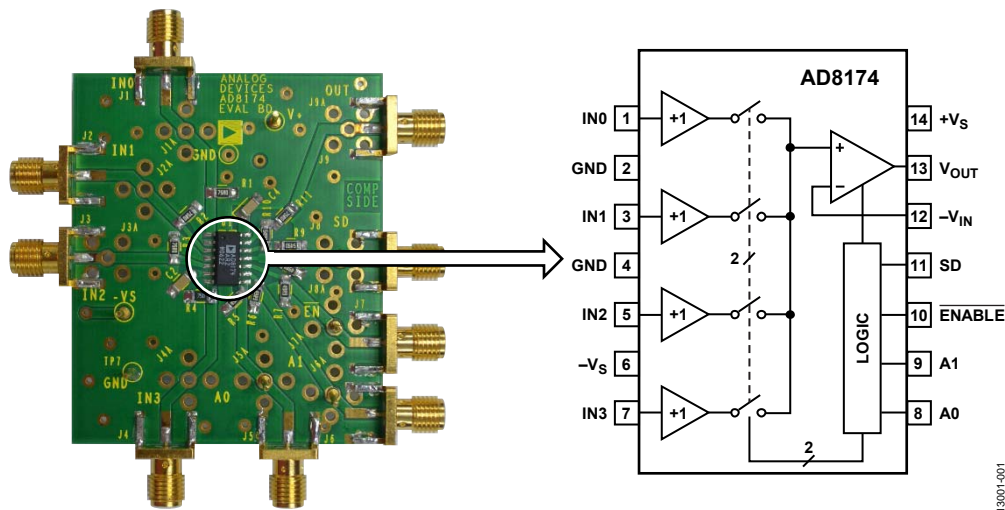

Figure 1. **AD8174** 4:1 Buffered Multiplexer.

13001-001

TABLE OF CONTENTS

Features	1	Introduction	3
Evaluation Kit Contents.....	1	Power Supply.....	3
Equipment Needed.....	1	Analog Inputs	3
General Description	1	Analog Output.....	3
Revision History	2	Shutdown (SD) and $\overline{\text{ENABLE}}$ Pins	3
Evaluation Board Hardware.....	3	Evaluation Board Schematic and Artwork.....	5

REVISION HISTORY

3/15—Revision 0: Initial Version

EVALUATION BOARD HARDWARE

INTRODUCTION

The AD8174-EB evaluation board allows the user to easily evaluate the AD8174 in its various gain configurations. Figure 2 shows the typical evaluation board setup used to evaluate the buffered multiplexer.

POWER SUPPLY

The AD8174-EB requires a typical ± 5 V power supply to power up the device via the $+V_S$ and $-V_S$ pins.

ANALOG INPUTS

The AD8174-EB has four input channels: IN0, IN1, IN2, and IN3. The input channels are activated by varying the voltage level of the digital control pins, A0 and A1. To make the digital control pins (A0 and A1) logic high, supply a minimum input of 2 V. To make the digital control pins (A0 and A1) logic low, supply a maximum input of 0.8 V. Table 1 shows the truth table for setting the inputs.

By default, all inputs are terminated with 75 Ω resistors in order to receive video signals. To use the evaluation board in nonvideo applications where 50 Ω termination is more popular, replace these resistors with 50 Ω values. Digital control pins, such as A0 and A1, are terminated with 50 Ω resistors to allow easy connection to laboratory equipment. Tie any unused input channels to ground.

ANALOG OUTPUT

The AD8174-EB has only one output (OUT) that can be put into a high impedance state for cascading stages by setting the ENABLE pin (see Table 1). OUT is terminated by default with a 75 Ω resistor.

By default, the gain of the output amplifier is set to +2, but other gain configurations can be set by replacing the two gain resistors. Table 2 shows the recommended resistor values for gain settings.

SHUTDOWN (SD) AND ENABLE PINS

The SD pin, if set to high, shuts off the supply current for all the switches, some of the logic control circuitry, and the amplifier, reducing the quiescent current drain to 1.5 mA.

The ENABLE pin, if set to high, shuts off the supply current of the amplifier, making the output of the amplifier into a high impedance that allows the AD8174-EB to be used in larger arrays.

Both the ENABLE and SD pins are terminated with 50 Ω resistors to allow easy connection to laboratory equipment. If the ENABLE and SD functions are not used, tie these respective pins to ground for proper operation.

Table 1. AD8174-EB Truth Table

A0	A1	ENABLE	SD	V _{OUT}
0	0	0	0	IN0
1	0	0	0	IN1
0	1	0	0	IN2
1	1	0	0	IN3
X ¹	X ¹	1	0	High-Z, I _S = 4.1 mA
X ¹	X ¹	X ¹	1	High-Z, I _S = 1.5 mA

¹ X = don't care.

Table 2. Recommended Feedback, Series Resistors, and Bandwidth vs. Capacitive Load and Gain

C _L (pF)	G = +1			G = +2			G = +3			G ≥ +4	
	R _F (k Ω)	R _{SOUT} (Ω)	V _{OUT} = 2 V p-p – 3 dB Bandwidth (MHz)	R _F (k Ω)	R _{SOUT} (Ω)	V _{OUT} = 2 V p-p – 3 dB Bandwidth (MHz)	R _F (Ω)	R _{SOUT} (Ω)	V _{OUT} = 2 V p-p – 3 dB Bandwidth (MHz)	R _F (Ω)	R _{SOUT} (Ω)
20	1	50	149	1	20	174	499	25	170	499	20
50	1	30	104	1	15	117	1 k	15	98	499	20
100	2	20	73	1	15	80	1 k	15	71	499	15
300	2	20	27	1	15	34	1 k	15	33	499	15

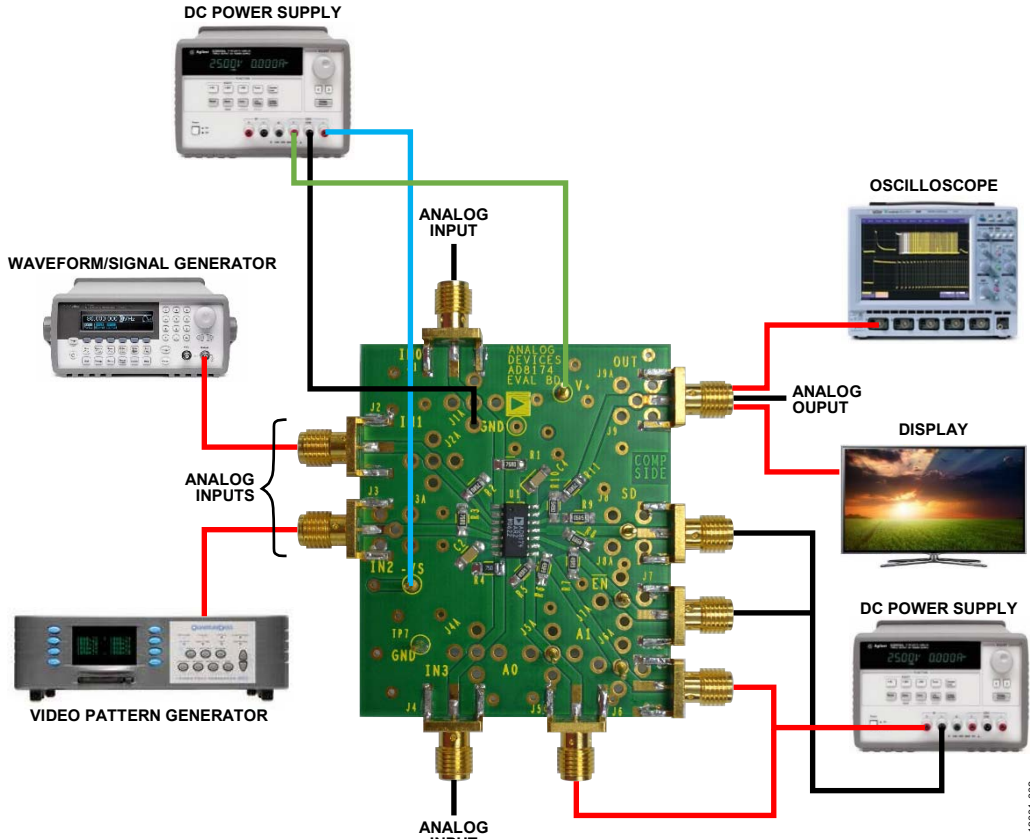

13001-002

Figure 2. Typical Evaluation Board Setup

EVALUATION BOARD SCHEMATIC AND ARTWORK

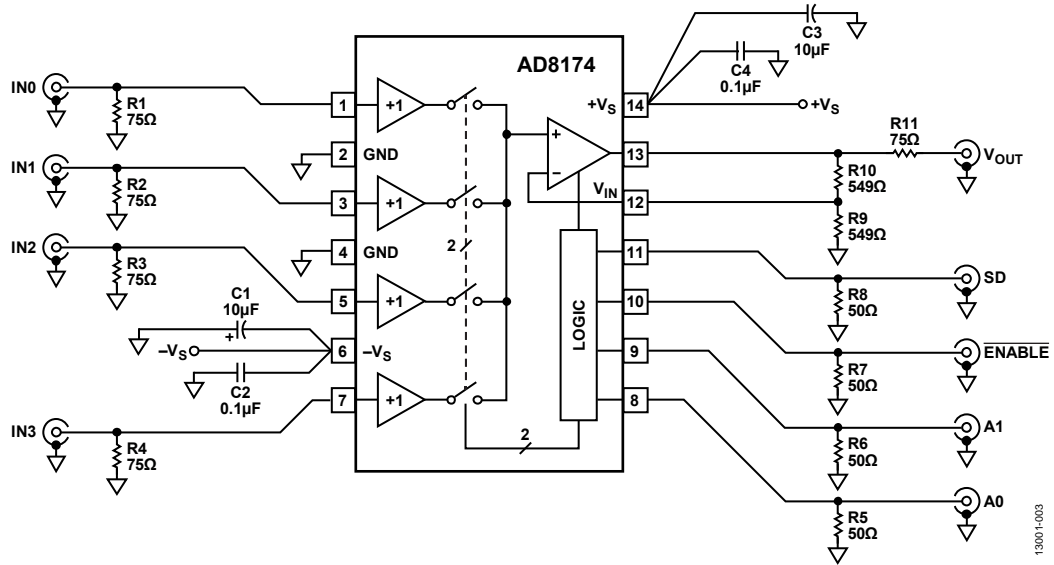

Figure 3. Evaluation Board Schematic

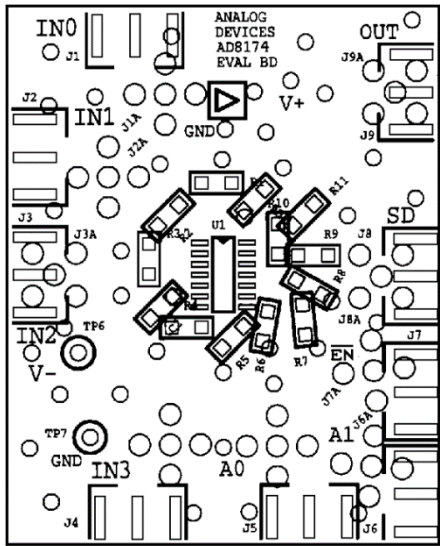

Figure 4. Component Side Silkscreen

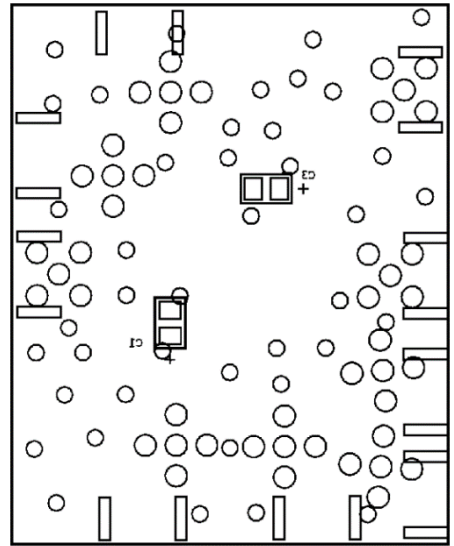

Figure 5. Solder Side Silkscreen

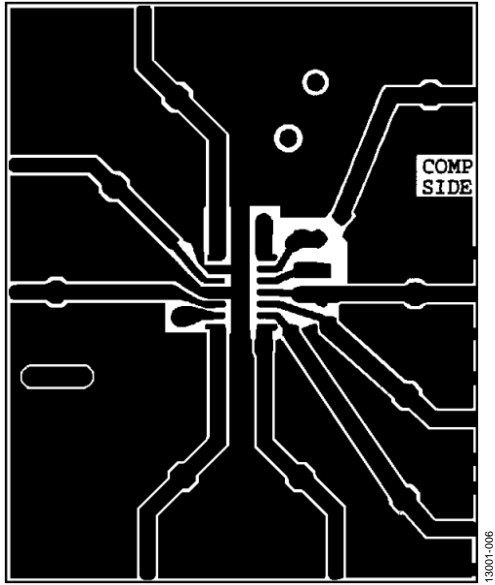

Figure 6. Component Side Layout



Figure 8. Solder Side Layout

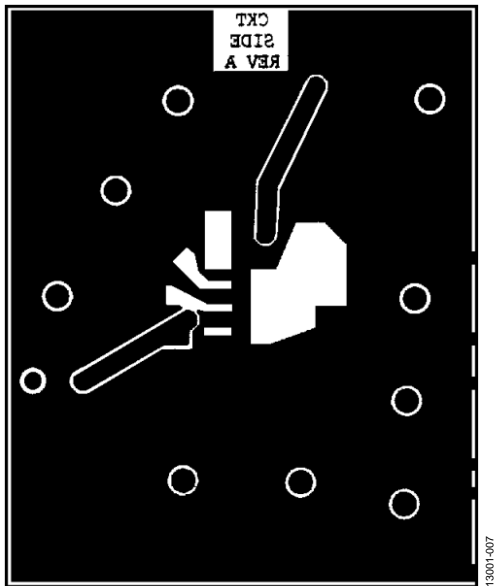

Figure 7. Evaluation Board Top View

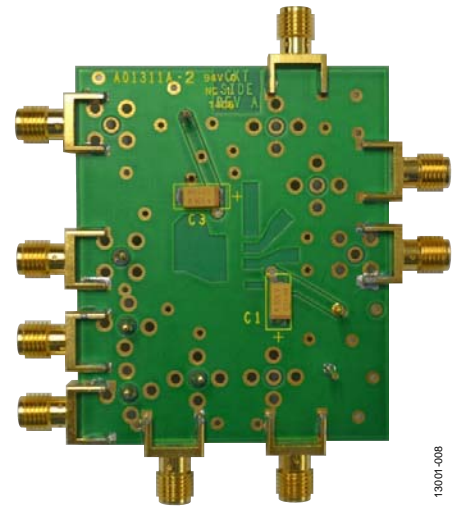

Figure 9. Evaluation Board Bottom View

NOTES



ESD Caution

ESD (electrostatic discharge) sensitive device. Charged devices and circuit boards can discharge without detection. Although this product features patented or proprietary protection circuitry, damage may occur on devices subjected to high energy ESD. Therefore, proper ESD precautions should be taken to avoid performance degradation or loss of functionality.

Legal Terms and Conditions

By using the evaluation board discussed herein (together with any tools, components documentation or support materials, the "Evaluation Board"), you are agreeing to be bound by the terms and conditions set forth below ("Agreement") unless you have purchased the Evaluation Board, in which case the Analog Devices Standard Terms and Conditions of Sale shall govern. Do not use the Evaluation Board until you have read and agreed to the Agreement. Your use of the Evaluation Board shall signify your acceptance of the Agreement. This Agreement is made by and between you ("Customer") and Analog Devices, Inc. ("ADI"), with its principal place of business at One Technology Way, Norwood, MA 02062, USA. Subject to the terms and conditions of the Agreement, ADI hereby grants to Customer a free, limited, personal, temporary, non-exclusive, non-sublicensable, non-transferable license to use the Evaluation Board FOR EVALUATION PURPOSES ONLY. Customer understands and agrees that the Evaluation Board is provided for the sole and exclusive purpose referenced above, and agrees not to use the Evaluation Board for any other purpose. Furthermore, the license granted is expressly made subject to the following additional limitations: Customer shall not (i) rent, lease, display, sell, transfer, assign, sublicense, or distribute the Evaluation Board; and (ii) permit any Third Party to access the Evaluation Board. As used herein, the term "Third Party" includes any entity other than ADI, Customer, their employees, affiliates and in-house consultants. The Evaluation Board is NOT sold to Customer; all rights not expressly granted herein, including ownership of the Evaluation Board, are reserved by ADI. CONFIDENTIALITY. This Agreement and the Evaluation Board shall all be considered the confidential and proprietary information of ADI. Customer may not disclose or transfer any portion of the Evaluation Board to any other party for any reason. Upon discontinuation of use of the Evaluation Board or termination of this Agreement, Customer agrees to promptly return the Evaluation Board to ADI. ADDITIONAL RESTRICTIONS. Customer may not disassemble, decompile or reverse engineer chips on the Evaluation Board. Customer shall inform ADI of any occurred damages or any modifications or alterations it makes to the Evaluation Board, including but not limited to soldering or any other activity that affects the material content of the Evaluation Board. Modifications to the Evaluation Board must comply with applicable law, including but not limited to the RoHS Directive. TERMINATION. ADI may terminate this Agreement at any time upon giving written notice to Customer. Customer agrees to return to ADI the Evaluation Board at that time. LIMITATION OF LIABILITY. THE EVALUATION BOARD PROVIDED HEREUNDER IS PROVIDED "AS IS" AND ADI MAKES NO WARRANTIES OR REPRESENTATIONS OF ANY KIND WITH RESPECT TO IT. ADI SPECIFICALLY DISCLAIMS ANY REPRESENTATIONS, ENDORSEMENTS, GUARANTEES, OR WARRANTIES, EXPRESS OR IMPLIED, RELATED TO THE EVALUATION BOARD INCLUDING, BUT NOT LIMITED TO, THE IMPLIED WARRANTY OF MERCHANTABILITY, TITLE, FITNESS FOR A PARTICULAR PURPOSE OR NON-INFRINGEMENT OF INTELLECTUAL PROPERTY RIGHTS. IN NO EVENT WILL ADI AND ITS LICENSORS BE LIABLE FOR ANY INCIDENTAL, SPECIAL, INDIRECT, OR CONSEQUENTIAL DAMAGES RESULTING FROM CUSTOMER'S POSSESSION OR USE OF THE EVALUATION BOARD, INCLUDING BUT NOT LIMITED TO LOST PROFITS, DELAY COSTS, LABOR COSTS OR LOSS OF GOODWILL. ADI'S TOTAL LIABILITY FROM ANY AND ALL CAUSES SHALL BE LIMITED TO THE AMOUNT OF ONE HUNDRED US DOLLARS (\$100.00). EXPORT. Customer agrees that it will not directly or indirectly export the Evaluation Board to another country, and that it will comply with all applicable United States federal laws and regulations relating to exports. GOVERNING LAW. This Agreement shall be governed by and construed in accordance with the substantive laws of the Commonwealth of Massachusetts (excluding conflict of law rules). Any legal action regarding this Agreement will be heard in the state or federal courts having jurisdiction in Suffolk County, Massachusetts, and Customer hereby submits to the personal jurisdiction and venue of such courts. The United Nations Convention on Contracts for the International Sale of Goods shall not apply to this Agreement and is expressly disclaimed.

Компания «Life Electronics» занимается поставками электронных компонентов импортного и отечественного производства от производителей и со складов крупных дистрибьюторов Европы, Америки и Азии.

С конца 2013 года компания активно расширяет линейку поставок компонентов по направлению коаксиальный кабель, кварцевые генераторы и конденсаторы (керамические, пленочные, электролитические), за счёт заключения дистрибьюторских договоров

Мы предлагаем:

- Конкуренеспособные цены и скидки постоянным клиентам.
- Специальные условия для постоянных клиентов.
- Подбор аналогов.
- Поставку компонентов в любых объемах, удовлетворяющих вашим потребностям.
- Приемлемые сроки поставки, возможна ускоренная поставка.
- Доставку товара в любую точку России и стран СНГ.
- Комплексную поставку.
- Работу по проектам и поставку образцов.
- Формирование склада под заказчика.
- Сертификаты соответствия на поставляемую продукцию (по желанию клиента).
- Тестирование поставляемой продукции.
- Поставку компонентов, требующих военную и космическую приемку.
- Входной контроль качества.
- Наличие сертификата ISO.

В составе нашей компании организован Конструкторский отдел, призванный помогать разработчикам, и инженерам.

Конструкторский отдел помогает осуществить:

- Регистрацию проекта у производителя компонентов.
- Техническую поддержку проекта.
- Защиту от снятия компонента с производства.
- Оценку стоимости проекта по компонентам.
- Изготовление тестовой платы монтаж и пусконаладочные работы.



Тел: +7 (812) 336 43 04 (многоканальный)
Email: org@lifeelectronics.ru