

NHD-3.5-320240MF-ASXV#

TFT (Thin-Film-Transistor) Color Liquid Crystal Display Module

NHD-	Newhaven Display
3.5-	3.5" Diagonal
320240-	320xRGBx240 Pixels
MF-	Model
A-	Built-in Driver / No Controller
S-	High Brightness, White LED Backlight
X-	TFT
V-	MVA, Wide Temperature
#	RoHS Compliant

Newhaven Display International, Inc.

2661 Galvin Ct.

Elgin IL, 60124

Ph: 847-844-8795

Fax: 847-844-8796

www.newhavendisplay.com

nhtech@newhavendisplay.com

nhsales@newhavendisplay.com

Document Revision History

Revision	Date	Description	Changed by
0	4/29/16	Initial Release	SB
1	6/30/16	Added Chromaticity	SB
2	9/23/16	Updated I_{LED} , I_{DD} , and Chromaticity Values	SB
3	6/19/19	Backlight Characteristics & Supply Current Updated	SB

Functions and Features

- 320xRGBx240 resolution
- LED backlight
- 3.3V power supply
- 24-bit Parallel digital RGB interface (6.4MHz)
- Premium high brightness display

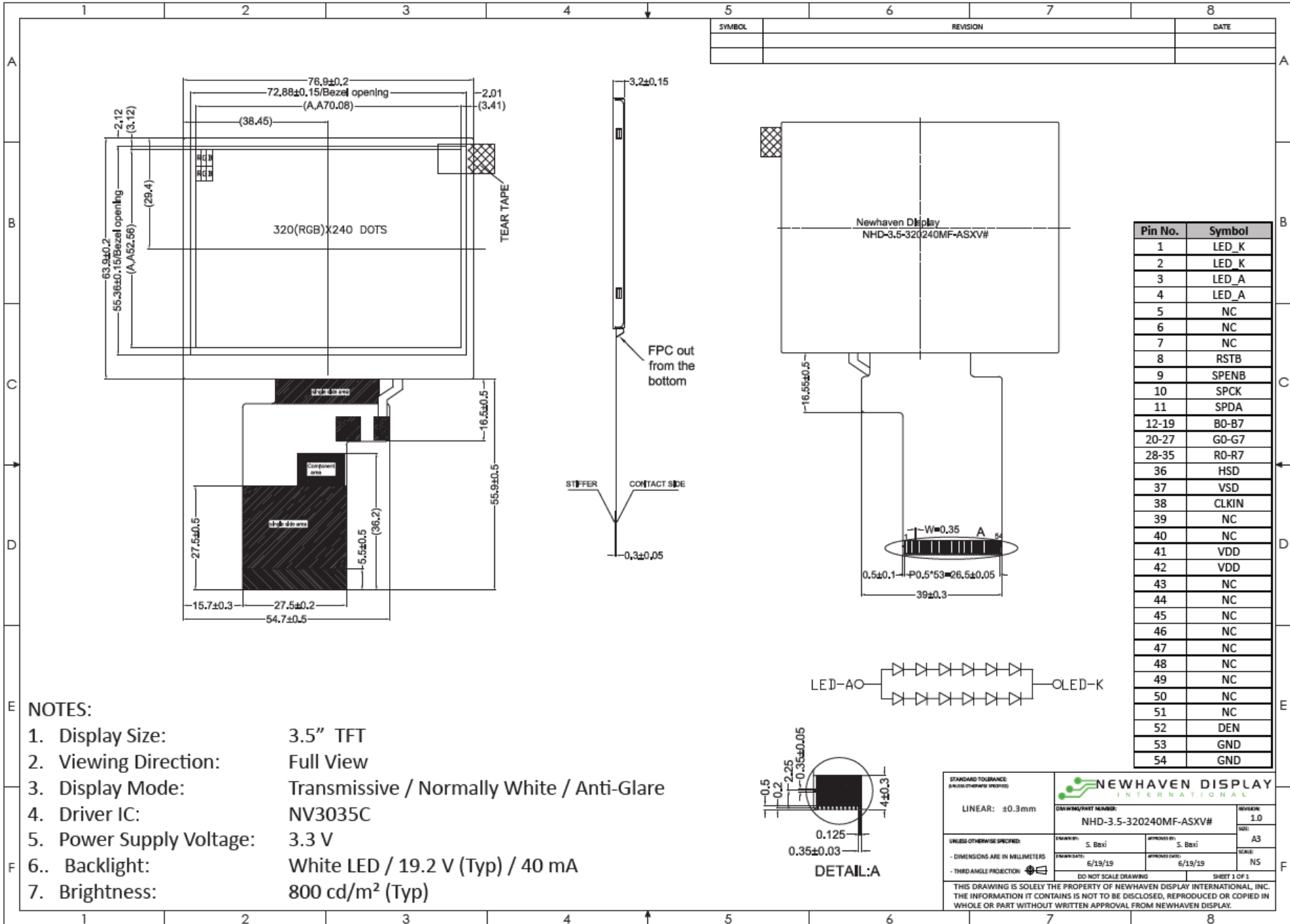

SYMBOL	REVISION	DATE

Pin No.	Symbol
1	LED_K
2	LED_K
3	LED_A
4	LED_A
5	NC
6	NC
7	NC
8	RSTB
9	SPENB
10	SPCK
11	SPDA
12-19	B0-B7
20-27	G0-G7
28-35	R0-R7
36	HSD
37	VSD
38	CLKIN
39	NC
40	NC
41	VDD
42	VDD
43	NC
44	NC
45	NC
46	NC
47	NC
48	NC
49	NC
50	NC
51	NC
52	DEN
53	GND
54	GND

- NOTES:**
- 1. Display Size: 3.5" TFT
 - 2. Viewing Direction: Full View
 - 3. Display Mode: Transmissive / Normally White / Anti-Glare
 - 4. Driver IC: NV3035C
 - 5. Power Supply Voltage: 3.3 V
 - 6. Backlight: White LED / 19.2 V (Typ) / 40 mA
 - 7. Brightness: 800 cd/m² (Typ)

STANDARD TOLERANCE:
UNLESS OTHERWISE SPECIFIED

LINEAR: ±0.3mm

UNLESS OTHERWISE SPECIFIED:
- DIMENSIONS ARE IN MILLIMETERS
- THIRD ANGLE PROJECTION

NEWHAVEN DISPLAY INTERNATIONAL

DRAWING/PART NUMBER:
NHD-3.5-320240MF-ASXV#

REVISION: 1.0

DATE: 6/19/19

SCALE: A3

DO NOT SCALE DRAWING

SHEET 1 OF 1

THIS DRAWING IS SOLELY THE PROPERTY OF NEWHAVEN DISPLAY INTERNATIONAL, INC. THE INFORMATION IT CONTAINS IS NOT TO BE DISCLOSED, REPRODUCED OR COPIED IN WHOLE OR PART WITHOUT WRITTEN APPROVAL FROM NEWHAVEN DISPLAY.

Pin Description

Pin No.	Symbol	External Connection	Function Description
1	LED_K	Power Supply	Backlight Cathode (Ground)
2	LED_K	Power Supply	Backlight Cathode (Ground)
3	LED_A	Power Supply	Backlight Anode (40mA @ 19.2V)
4	LED_A	Power Supply	Backlight Anode (40mA @ 19.2V)
5	NC	-	No Connect
6	NC	-	No Connect
7	NC	-	No Connect
8	RSTB	MPU	Active LOW Reset signal
9	SPENB	MPU	Active LOW Serial Chip Select signal
10	SPCK	MPU	Serial Clock signal
11	SPDA	MPU	Serial Data signal
12-19	B0-B7	MPU	Blue Data signals
20-27	G0-G7	MPU	Green Data signals
28-35	R0-R7	MPU	Red Data signals
36	HSD	MPU	Horizontal (Line) Sync signal
37	VSD	MPU	Vertical (Frame) Sync signal
38	CLKIN	MPU	Dot Clock signal
39	NC	-	No Connect
40	NC	-	No Connect
41	VDD	Power Supply	Supply Voltage for LCD and logic (3.3V)
42	VDD	Power Supply	Supply Voltage for LCD and logic (3.3V)
43	NC	-	No Connect
44	NC	-	No Connect
45	NC	-	No Connect
46	NC	-	No Connect
47	NC	-	No Connect
48	NC	-	No Connect
49	NC	-	No Connect
50	NC	-	No Connect
51	NC	-	No Connect
52	DEN	-	Data Enable signal (No Connect)
53	GND	Power Supply	Ground
54	GND	Power Supply	Ground

Recommended connector: 54pin, 0.5mm pitch, FFC connector. Molex P/N 51296-5494

Electrical Characteristics

Item	Symbol	Condition	Min.	Typ.	Max.	Unit
Operating Temperature Range	T _{OP}	Absolute Max	-20	-	+70	°C
Storage Temperature Range	T _{ST}	Absolute Max	-30	-	+80	°C
Digital Supply Voltage	V _{DD}	-	3.0	3.3	3.6	V
Supply Current	I _{DD}	V _{DD} =3.3V	5	10	15	mA
"H" Level input	V _{IH}	-	0.8*V _{DD}	-	V _{DD}	V
"L" Level input	V _{IL}	-	V _{SS}	-	0.2*V _{DD}	V
"H" Level output	V _{OH}	-	V _{DD} -0.4	-	V _{DD}	V
"L" Level output	V _{OL}	-	V _{SS}	-	V _{SS} +0.4	V
Backlight Supply Current	I _{LED}	-	30	40	50	mA
Backlight Supply Voltage	V _{LED}	I _{LED} = 40 mA	17.4	19.2	19.8	V
Backlight Lifetime*	-	T _{OP} = 25° C	20,000	50,000	-	Hrs.

*Backlight lifetime is rated as Hours until **half-brightness**, under normal operating conditions. The LED of the backlight is driven by current drain; drive voltage is for reference only. Drive voltage must be selected to ensure backlight current drain is below MAX level stated

Optical Characteristics

Item	Symbol	Condition	Min.	Typ.	Max.	Unit	
Optimal Viewing Angles	Top	φY+	CR ≥ 10	-	70	-	°
	Bottom	φY-		-	70	-	°
	Left	θX-		-	70	-	°
	Right	θX+		-	70	-	°
Contrast Ratio	CR	-	200	350	-	-	
Luminance	L _V	I _{LED} = 40 mA	640	800	-	cd/m ²	
Response Time	Rise	T _R	T _{OP} = 25° C	-	25	40	ms
	Fall	T _F		-	25	40	ms
Chromaticity	Red	X _R	-	0.554	0.604	0.654	-
		Y _R	-	0.298	0.345	0.395	-
	Green	X _G	-	0.263	0.313	0.363	-
		Y _G	-	0.552	0.602	0.652	-
	Blue	X _B	-	0.094	0.144	0.194	-
		Y _B	-	0.056	0.106	0.156	-
	White	X _W	-	0.229	0.279	0.329	-
		Y _W	-	0.271	0.321	0.371	-

Driver Information

Built-in NV3035C driver. No controller.

Please download specification at http://www.newhavendisplay.com/app_notes/NV3035C.pdf

Note: To achieve optimum VCOM and VGL settings, the SPI interface may be used to set the following registers:

ROEh = 6Bh

ROFh = 24h

Timing Characteristics

Parameter	Symbol	Min.	Typ.	Max.	Unit	Conditions
System Operation Timing						
VDD power source slew time	T _{POr}			1000	us	From 0V to 90% VDD
RSTB active pulse width	T _{RSTB}	40			us	VDD=3.3V
Input Output Timing						
CLKIN clock time	Tclk	-		35.7	ns	Please refer to timing table(P25)
HSD to CLKIN	T _{hc}	-	-	1	CLKIN	
HSD width	T _{hwh}	1	-	-	CLKIN	
VSD width	T _{vwh}	1	-	-	Th	
HSD period time	T _h	60	63.56	67	us	
VSD setup time	T _{vst}	12	-	-	ns	
VSD hold time	T _{vhd}	12	-	-	ns	
HSD setup time	T _{hst}	12	-	-	ns	
HSD hold time	T _{hhd}	12	-	-	ns	
Data set-up time	T _{dsu}	12	-	-	ns	DIN[23:0] to CLKIN
Data hold time	T _{dhd}	12	-	-	ns	DIN[23:0] to CLKIN
DEN setup time	T _{esd}	12	-		ns	DEN to CLKIN
Time that VSD to 1 st line data input	T _{vs}	2	13	127	Th	@CIR601/8bit RGB HV mode Control by HDLY[6:0] setting T _{vs} =HDLY[6:0]
Time that CCIR_V to 1 st line data input	T _{vs}	12	20	28	Th	@CCIR656 NTSC mode Control by HDLY[6:0] setting T _{vs} =HDLY[6:0]
Time that CCIR_V to 1 st line data input	T _{vs}	17	25	33	Th	@CCIR656 PAL mode Control by HDLY[6:0] setting T _{vs} =HDLY[6:0]
Time that VSD to 1 st line data input	T _{vs}	2	13	127	Th	@24bit RGB HV mode Control by HDLY[6:0] setting T _{vs} =HDLY[6:0]
Source output stable time 1	T _{st}	-	25	30	us	96% final, CL=30pF, RL=2K
Gate output stable time	T _{gst}	-	500	1000	ns	96% final, CL=40pF
VCOMOUT output stable time	T _{est}	-	4	8	us	96% final, CL=33nF, RL=100ohm
3-wire serial communication AC timing						
Serial clock	T _{spck}	320	-	-	ns	
SPCK pulse duty	T _{scdut}	40	50	60	%	T _{ckh} /T _{spck}
Serial data setup time	T _{isu}	120	-	-	ns	
Serial data hold time	T _{ihd}	120	-	-	ns	
Serial clock high/low	T _{ssw}	120	-	-	ns	
Chip select distinguish	T _{cd}	1	-	-	us	
SPENA to VSD	T _{ev}	1	-	-	us	
SPENB input setup time	T _{eck}	150	-	-	Ns	
SPENB input hold time	T _{cke}	150	-	-	ns	

Parameter	Symbol	Min.	Typ.	Max.	Unit	Conditions
CLKIN frequency	Fclk	6.1	6.4	8.0	MHz	VDD=3.0~3.6V
CLKIN cycle time	Tclk	125	156	164	ns	
CLKIN pulse duty	T _{cwh}	40	50	60	%	Tclk
Time that HSD to 1 st data input(NTSC)	T _{hs}	40	70	255	CLKIN	DDLY=70,Offset=0(fixed)

Input Data Format

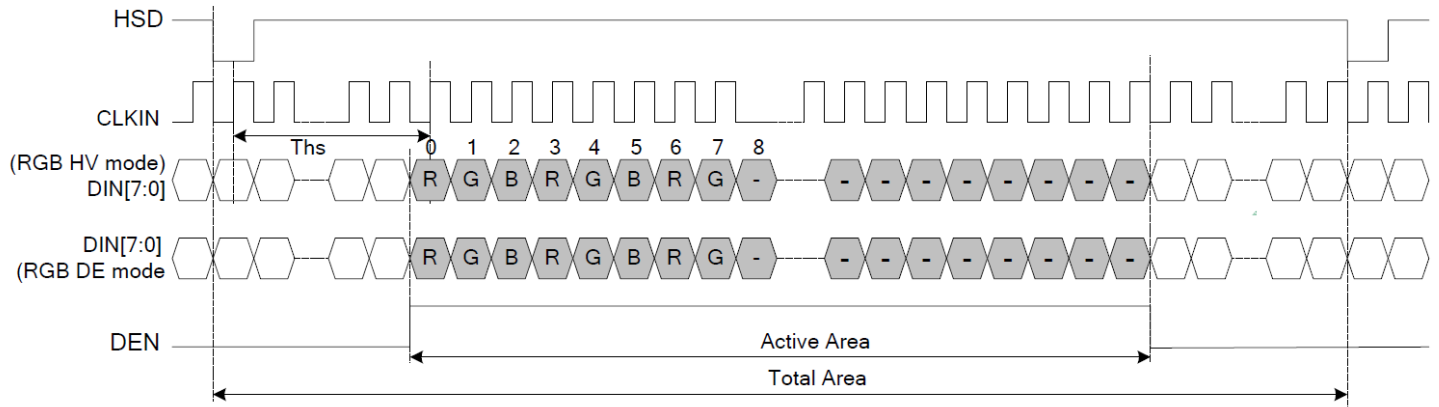

Clock and Data Input Timing Diagram

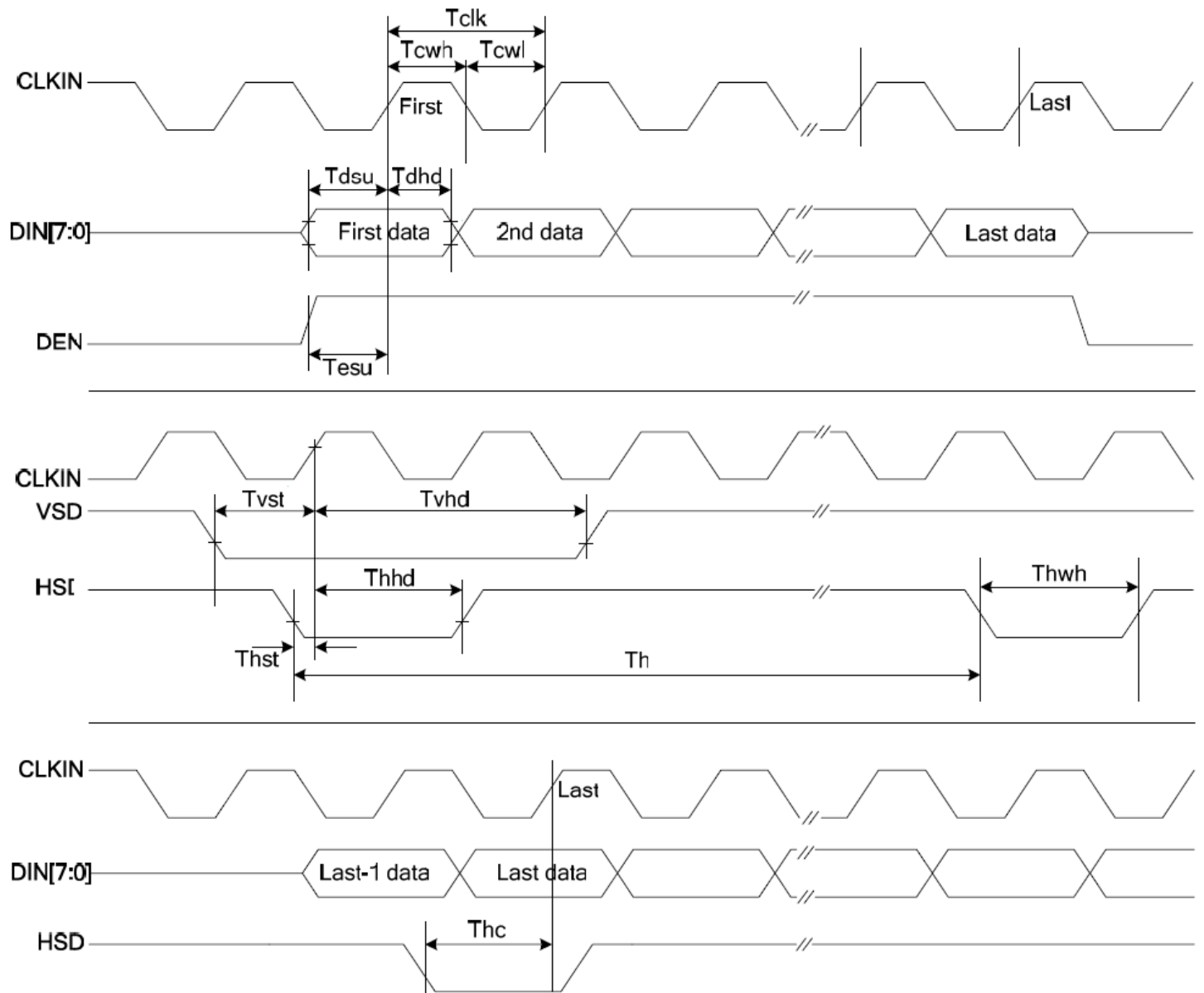

3-wire Timing Diagram

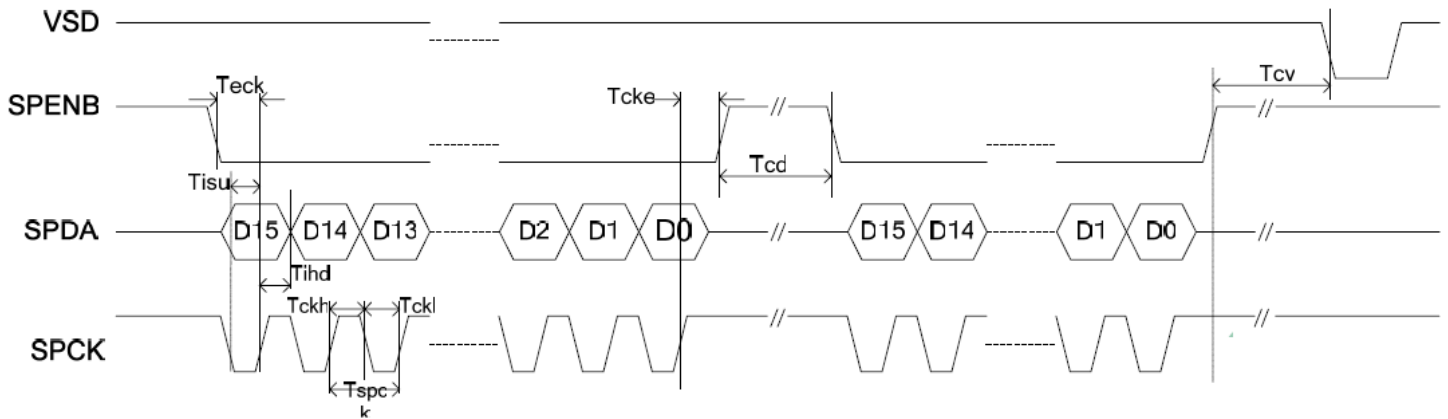

Input Data Timing

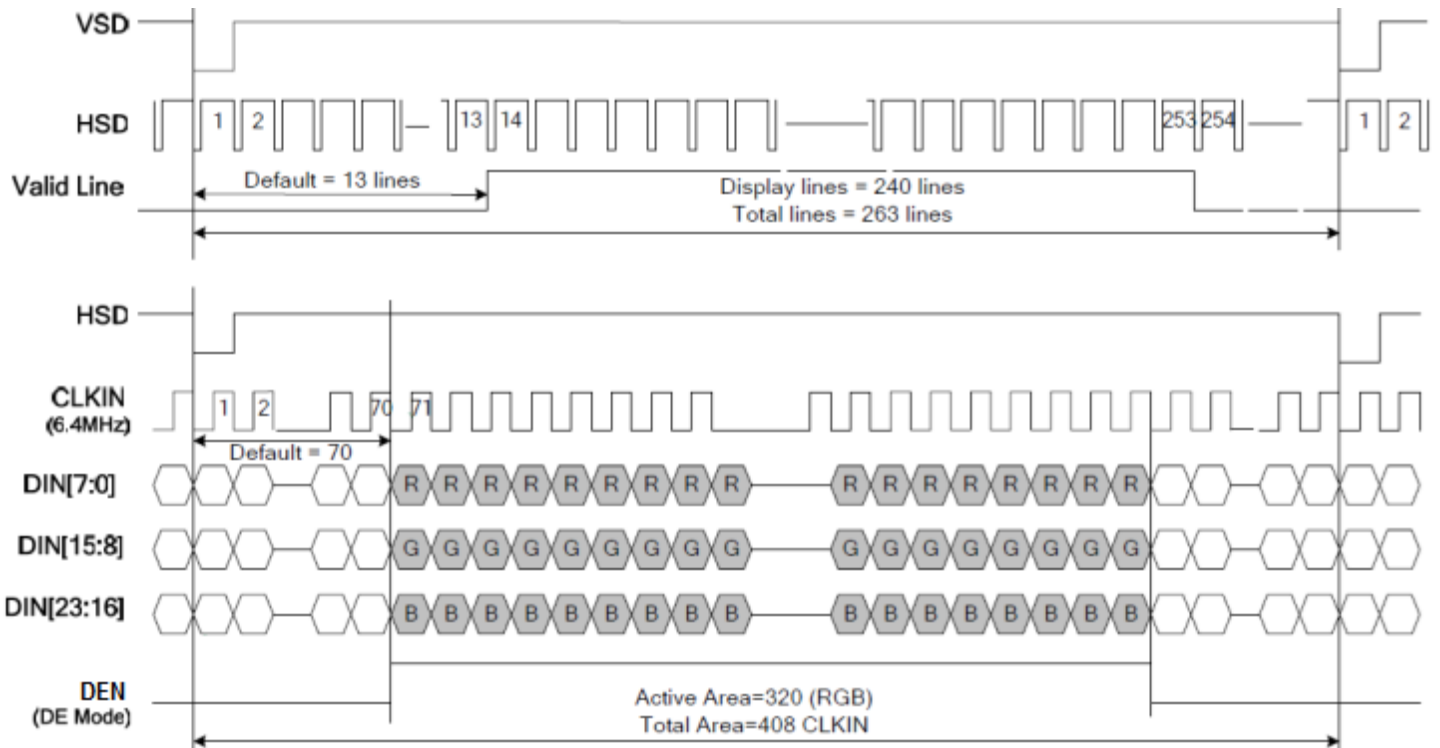

Quality Information

Test Item	Content of Test	Test Condition	Note
High Temperature storage	Endurance test applying the high storage temperature for a long time.	+70°C , 240hrs	2
Low Temperature storage	Endurance test applying the low storage temperature for a long time.	-30°C , 240hrs	1,2
High Temperature Operation	Endurance test applying the electric stress (voltage & current) and the high thermal stress for a long time.	+60°C , 240hrs	2
Low Temperature Operation	Endurance test applying the electric stress (voltage & current) and the low thermal stress for a long time.	-20°C , 240hrs	1,2
High Temperature / Humidity Operation	Endurance test applying the electric stress (voltage & current) and the high thermal with high humidity stress for a long time.	+60°C , 90% RH , 160hrs	1,2
Thermal Shock resistance	Endurance test applying the electric stress (voltage & current) during a cycle of low and high thermal stress.	-30°C,30min -> 25°C,5min -> 80°C,30min = 1 cycle 100 cycles	
Vibration test	Endurance test applying vibration to simulate transportation and use.	10-55Hz , 15mm amplitude. 60 sec in each of 3 directions X,Y,Z For 15 minutes	3
Static electricity test	Endurance test applying electric static discharge.	VS=4KV, RS=330kΩ, CS=150pF Five times	

Note 1: No condensation to be observed.

Note 2: Conducted after 4 hours of storage at 25°C, 0%RH.

Note 3: Test performed on product itself, not inside a container.

Precautions for using LCDs/LCMs

See Precautions at www.newhavendisplay.com/specs/precautions.pdf

Warranty Information and Terms & Conditions

http://www.newhavendisplay.com/index.php?main_page=terms

Компания «Life Electronics» занимается поставками электронных компонентов импортного и отечественного производства от производителей и со складов крупных дистрибьюторов Европы, Америки и Азии.

С конца 2013 года компания активно расширяет линейку поставок компонентов по направлению коаксиальный кабель, кварцевые генераторы и конденсаторы (керамические, пленочные, электролитические), за счёт заключения дистрибьюторских договоров

Мы предлагаем:

- Конкуренспособные цены и скидки постоянным клиентам.
- Специальные условия для постоянных клиентов.
- Подбор аналогов.
- Поставку компонентов в любых объемах, удовлетворяющих вашим потребностям.
- Приемлемые сроки поставки, возможна ускоренная поставка.
- Доставку товара в любую точку России и стран СНГ.
- Комплексную поставку.
- Работу по проектам и поставку образцов.
- Формирование склада под заказчика.
- Сертификаты соответствия на поставляемую продукцию (по желанию клиента).
- Тестирование поставляемой продукции.
- Поставку компонентов, требующих военную и космическую приемку.
- Входной контроль качества.
- Наличие сертификата ISO.

В составе нашей компании организован Конструкторский отдел, призванный помогать разработчикам, и инженерам.

Конструкторский отдел помогает осуществить:

- Регистрацию проекта у производителя компонентов.
- Техническую поддержку проекта.
- Защиту от снятия компонента с производства.
- Оценку стоимости проекта по компонентам.
- Изготовление тестовой платы монтаж и пусконаладочные работы.

