

Power over Ethernet (PoE) powered 45 W LED driver with Bluetooth Low Energy (BLE) enabled control reference design

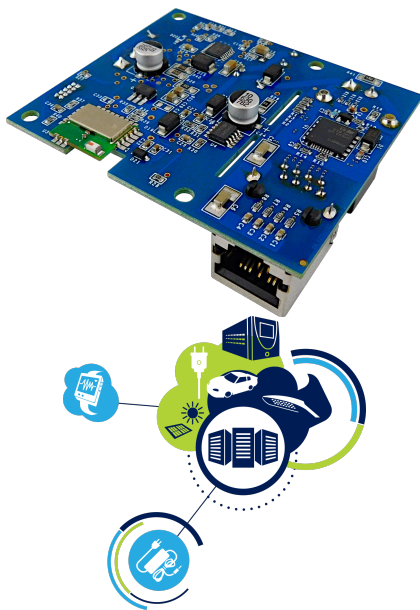

Features

- PoE-PD IEEE 802.3af/at/bt compliant
- Constant current output, working in buck topology
- Output current – 1.4 A with < 0.05% current regulation
 - Number of LEDs connected at output: 6 – 11 white LEDs (3.3 V each)
- Wireless ON/OFF and dimming control with [PoE_Lighting](#) Android application
- Digital dimming with 1% resolution
- LED driver input voltage range 37 – 57 V_{DC}
- Peak efficiency at maximum load > 95%
- Low standby power consumption < 100 mW
- Comprehensive set of protections:
 - open/no-load circuit protection
 - short/overload circuit protection
- RoHS compliant
- WEEE compliant

Description

The [STEVAL-POEL45W1](#) Power over Ethernet (PoE) powered LED driver reference design delivers a power output of 45 W and dims LEDs down to 1% of the maximum brightness without any flicker. The solution supports remote dimming control via Bluetooth with the [PoE_Lighting](#) Android application (available on [Google Play](#)).

You can use this reference design to develop complete indoor network-powered lighting solutions with IP-based Powered Devices (PDs), without additional AC power infrastructure, and extend the functionality to include remote data management via existing LAN networks.

The reference design features a highly integrated [PM8805](#) IEEE802.3bt-compliant Powered Device (PD) PoE interface, a high efficiency [LED6000](#) LED driver able to source up to 3 A_{DC} current, and a certified [SPBTLE-1S](#) Bluetooth Low Energy module, compliant with BT specifications v4.2 and BQE qualified.

The [STSW-POEL45FW](#) board firmware is programmed via the [STSW-BNRG1STLINK](#) utility.

Product summary	
Power over Ethernet (PoE) supplied, 45 W LED driver with Bluetooth Low Energy (BLE) enabled control reference design	STEVAL-POEL45W1
IEEE802.3bt PoE-PD interface with integrated dual-active bridge	PM8805
3 A, 61 V monolithic current source with dimming capability	LED6000
Very low power application module for Bluetooth Smart v4.2	SPBTLE-1S
Firmware for the STEVAL-POEL45W1 PoE-enabled constant current LED driver	STSW-POEL45FW
Android app for STEVAL-POEL45W1 LED driver	PoE_Lighting

1 Schematic diagrams

Figure 1. STEVAL-POEL45W1 board schematic (1 of 2)

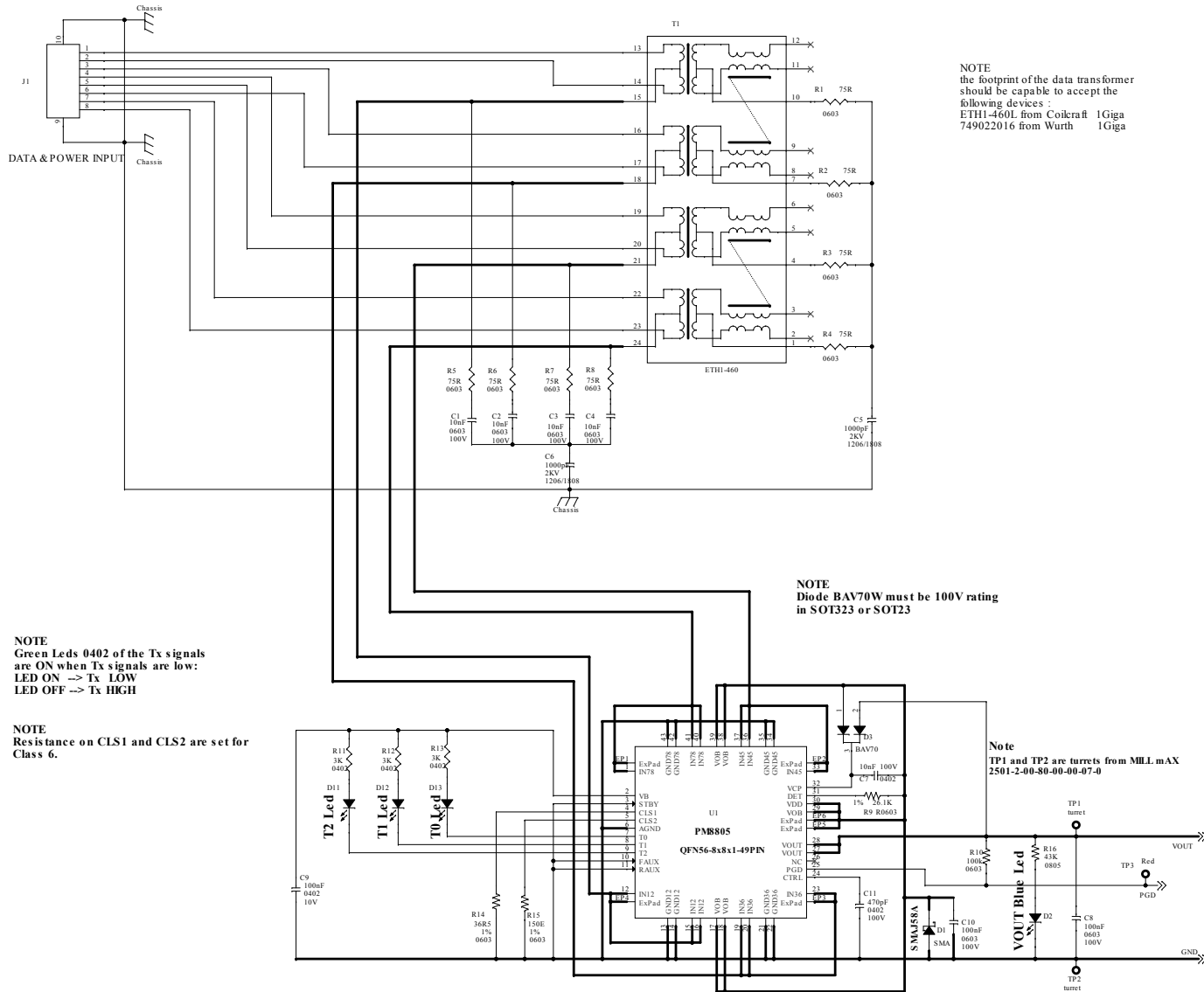
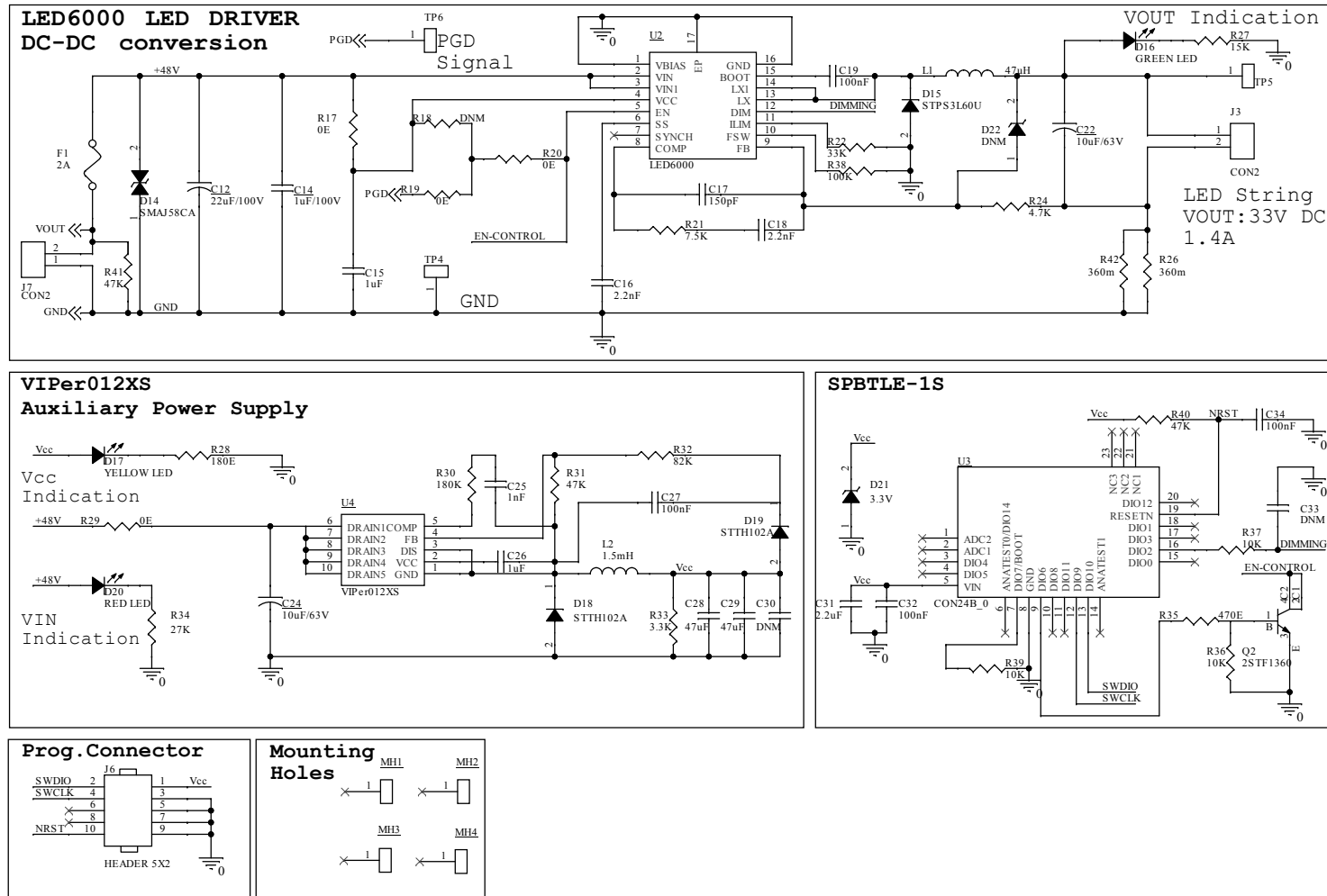

Figure 2. STEVAL-POEL45W1 board schematic (2 of 2)



Revision history

Table 1. Document revision history

Date	Version	Changes
10-Oct-2018	1	Initial release.
05-Mar-2019	2	Updated product summary table.
18-Apr-2019	3	Updated cover page title, image, product summary table, features and description.

IMPORTANT NOTICE – PLEASE READ CAREFULLY

STMicroelectronics NV and its subsidiaries (“ST”) reserve the right to make changes, corrections, enhancements, modifications, and improvements to ST products and/or to this document at any time without notice. Purchasers should obtain the latest relevant information on ST products before placing orders. ST products are sold pursuant to ST’s terms and conditions of sale in place at the time of order acknowledgement.

Purchasers are solely responsible for the choice, selection, and use of ST products and ST assumes no liability for application assistance or the design of Purchasers’ products.

No license, express or implied, to any intellectual property right is granted by ST herein.

Resale of ST products with provisions different from the information set forth herein shall void any warranty granted by ST for such product.

ST and the ST logo are trademarks of ST. For additional information about ST trademarks, please refer to www.st.com/trademarks. All other product or service names are the property of their respective owners.

Information in this document supersedes and replaces information previously supplied in any prior versions of this document.

© 2019 STMicroelectronics – All rights reserved

Компания «Life Electronics» занимается поставками электронных компонентов импортного и отечественного производства от производителей и со складов крупных дистрибьюторов Европы, Америки и Азии.

С конца 2013 года компания активно расширяет линейку поставок компонентов по направлению коаксиальный кабель, кварцевые генераторы и конденсаторы (керамические, пленочные, электролитические), за счёт заключения дистрибьюторских договоров

Мы предлагаем:

- Конкурентоспособные цены и скидки постоянным клиентам.
- Специальные условия для постоянных клиентов.
- Подбор аналогов.
- Поставку компонентов в любых объемах, удовлетворяющих вашим потребностям.
- Приемлемые сроки поставки, возможна ускоренная поставка.
- Доставку товара в любую точку России и стран СНГ.
- Комплексную поставку.
- Работу по проектам и поставку образцов.
- Формирование склада под заказчика.
- Сертификаты соответствия на поставляемую продукцию (по желанию клиента).
- Тестирование поставляемой продукции.
- Поставку компонентов, требующих военную и космическую приемку.
- Входной контроль качества.
- Наличие сертификата ISO.

В составе нашей компании организован Конструкторский отдел, призванный помогать разработчикам, и инженерам.

Конструкторский отдел помогает осуществить:

- Регистрацию проекта у производителя компонентов.
- Техническую поддержку проекта.
- Защиту от снятия компонента с производства.
- Оценку стоимости проекта по компонентам.
- Изготовление тестовой платы монтаж и пусконаладочные работы.



Тел: +7 (812) 336 43 04 (многоканальный)
Email: org@lifeelectronics.ru