

Datasheet SPS30

Particulate Matter Sensor for Air Quality Monitoring and Control

- Unique long-term stability
- Advanced particle size binning
- Superior accuracy in mass-concentration sensing
- Small, ultra-slim package
- Fully calibrated digital output



Product Summary

The SPS30 Particulate Matter (PM) sensor is a technological breakthrough in optical PM sensors. Its measurement principle is based on laser scattering and makes use of Sensirion's innovative contamination-resistance technology. This technology, together with high-quality and long-lasting components, enables accurate measurements from its first operation and throughout its lifetime of more than eight years. In addition, Sensirion's advanced algorithms provide superior accuracy for different PM types and higher-resolution particle size binning, opening up new possibilities for the detection of different sorts of environmental dust and other particles. With dimensions of only 41 x 41 x 12 mm³, it is also the perfect solution for applications where size is of paramount importance, such as wall-mounted or compact air quality devices.

Content

1 Particulate Matter Sensor Specifications	2
2 Electrical Specifications	3
3 Hardware Interface Specifications	4
4 Operation and Communication through the UART Interface	5
5 Operation and Communication through the I ² C Interface	11
6 Technical Drawings	17
7 Shipping Package	18
8 Ordering Information	18
9 Important Notices	19
10 Headquarters and Subsidiaries	20

1 Particulate Matter Sensor Specifications

Default conditions of 25 °C and 5 V supply voltage apply to values in the table below, unless otherwise stated.

Parameter	Conditions	Value	Units
Mass concentration accuracy ¹	0 to 100 µg/m ³	±10	µg/m ³
	100 to 1'000 µg/m ³	±10	%
Mass concentration range	-	0 to 1'000	µg/m ³
Mass concentration resolution	-	1	µg/m ³
Mass concentration size range ²	PM1.0	0.3 to 1.0	µm
	PM2.5	0.3 to 2.5	µm
	PM4	0.3 to 4.0	µm
	PM10	0.3 to 10.0	µm
Number concentration range	-	0 to 3'000	1/cm ³
Number concentration size range ²	PM0.5	0.3 to 0.5	µm
	PM1.0	0.3 to 1.0	µm
	PM2.5	0.3 to 2.5	µm
	PM4	0.3 to 4.0	µm
	PM10	0.3 to 10.0	µm
Sampling interval	-	1	s
Start-up time	-	< 8	s
Lifetime ³	24 h/day operation	> 8	years
Acoustic emission level	0.2 m	25	dB(A)
Weight	-	26	g

Table 1: Particulate Matter sensor specifications.

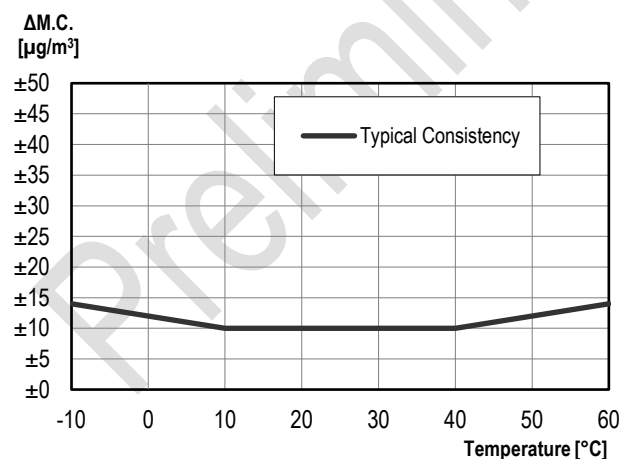

Figure 1: Typical consistency tolerance for PM2.5 in µg/m³ between 0-100 µg/m³.

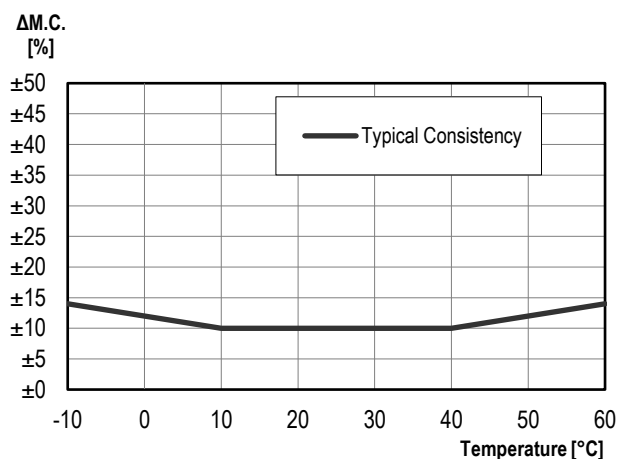

Figure 2: Typical consistency tolerance for PM2.5 in % between 100-1000 µg/m³.

¹ Deviation to TSI DustTrak™ DRX Aerosol Monitor 8533 reference. PM2.5 accuracy is verified for every sensor after calibration using a defined potassium chloride particle distribution. Ask Sensirion for further details on accuracy characterization procedures.

² PMx defines particles with a size smaller than "x" micrometers (e.g., PM2.5 = particles smaller than 2.5 µm).

³ Validated with accelerated aging tests. Ask Sensirion for further details on accelerated aging validation procedures. Lifetime might vary depending on different operating conditions.

1.1 Recommended Operating Conditions

The sensor shows best performance when operated within recommended normal temperature and humidity range of 10 – 40 °C and 20 – 80 %RH, respectively.

2 Electrical Specifications

2.1 Electrical Characteristics

Default conditions of 25 °C and 5 V supply voltage apply to values in the table below, unless otherwise stated.

Parameter	Conditions	Value	Units
Supply voltage	-	4.5 to 5.5	V
Idle current	Idle-Mode	< 8	mA
Average supply current	Measurement-Mode	60	mA
Max. supply current	First ~200 ms after start of Measurement-Mode	80	mA
Input high level voltage (V _{IH})	-	> 2.31	V
Input low level voltage (V _{IL})	-	< 0.99	V
Output high level voltage (V _{OH})	-	> 2.9	V
Output low level voltage (V _{OL})	-	< 0.4	V

Table 2: Electrical specifications.

2.2 Absolute Minimum and Maximum Ratings

Stress levels beyond those listed in Table 3 may cause permanent damage to the device. These are stress ratings only and functional operation of the device at these conditions cannot be guaranteed. Exposure to the absolute maximum rating conditions for extended periods may affect the reliability of the device.

Parameter	Rating
Supply voltage VDD	-0.3 to 5.5 V
Interface Select SEL	-0.3 to 4.0 V
I/O pins (RX/SDA, TX/SCL)	-0.3 to 5.5 V
Max. current on any I/O pin	±16 mA
Operating temperature range	-10 to +60 °C
Storage temperature range	-40 to +70 °C
Operating humidity range	0 to 95 %RH (non-condensing)
ESD CDM (charge device model) ⁴	±4 kV contact, ±8 kV air
Electromagnetic field immunity to high frequencies ⁵	3 V/m (80 MHz to 1000 MHz)
High frequency electromagnetic emission ⁶	30 dB 30 MHz to 230 MHz; 37 dB 230 MHz to 1000 MHz
Low frequency electromagnetic emission ⁷	30-40 dB 0.15 MHz to 30 MHz

Table 3: Absolute minimum and maximum ratings.

⁴ According to IEC 61000-4-2.

⁵ According to IEC 61000-4-3.

⁶ According to CISPR 14.

⁷ According to CISPR 22.

3 Hardware Interface Specifications

The interface connector is located at the side of the sensor opposite to the air inlet/outlet. Corresponding female plug is ZHR-5 from JST Sales America Inc. In Figure 3 a description of the pin layout is given.

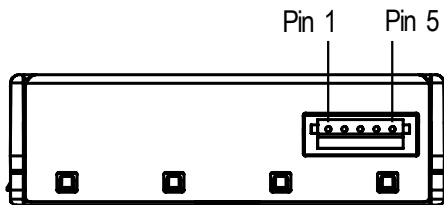

Pin	Name	Description	Comments
1	VDD	Supply voltage	5V ± 10%
2	RX	UART: Receiving pin for communication	TTL 5V and LVTTTL 3.3V compatible
	SDA	I ² C: Serial data input / output	
3	TX	UART: Transmitting pin for communication	TTL 5V and LVTTTL 3.3V compatible
	SCL	I ² C: Serial clock input	
4	SEL	Interface select	Leave floating to select UART
			Pull to GND to select I ² C
5	GND	Ground	

Figure 3 The communication interface connector is located at the side of the sensor opposite to the air outlet.

Table 4 SPS30 pin assignment.

The SPS30 offers both a UART⁸ and an I²C interface. For connection cables longer than 20 cm we recommend using the UART interface, due to its intrinsic robustness against electromagnetic interference.

3.1 Physical Layer

The SPS30 has separate RX and TX lines with unipolar logic levels. A transmitted byte looks as in Figure 4.

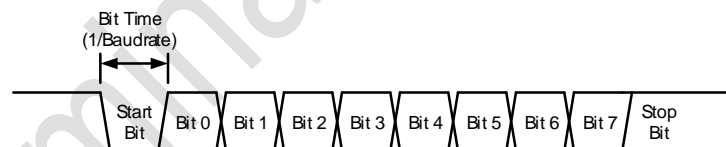
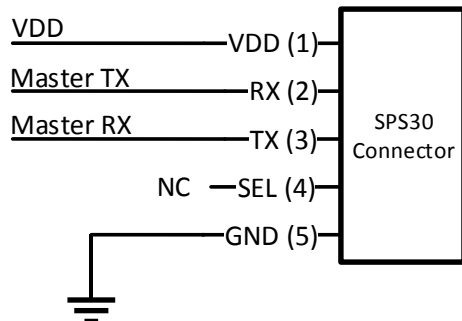

Figure 4 Transmitted byte.

⁸ Universal Asynchronous Receiver Transmitter.

4 Operation and Communication through the UART Interface



The following UART settings have to be used:

- Baud Rate: 115'200 bit/s
- Data Bits: 8
- Parity: None
- Stop Bit: 1

Figure 5 Typical UART application circuit.

4.1 SHDLIC Frame Layer

On top of the UART interface, the SPS30 uses the very powerful and easy-to-implement SHDLIC⁹ protocol. It is a serial communication protocol based on a master/slave architecture. The SPS30 acts as the slave device.

Data is transferred in logical units called frames. Every transfer is initiated by the master sending a MOSI¹⁰ frame. The slave will respond to the MOSI frame with a slave response, or MISO¹¹ frame. The two types of frames are shown in Figure 6.

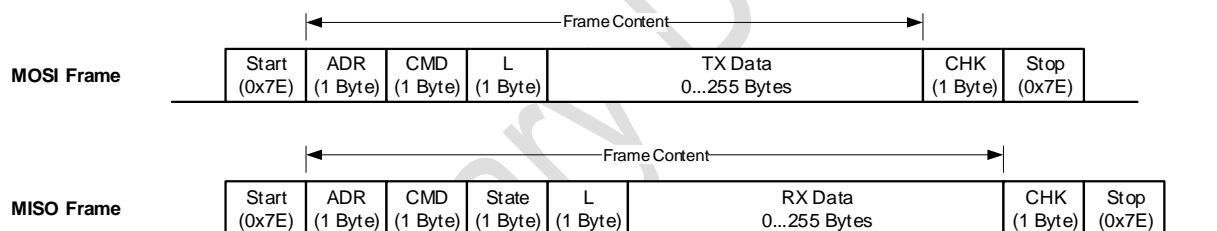

Figure 6 MOSI and MISO frames structure.

Start and Stop Byte (0x7E)

The 0x7E character is sent at the beginning and at the end of the frame to signalize frame start and stop. If this byte (0x7E) occurs anywhere else in the frame, it must be replaced by two other bytes (byte-stuffing). This also applies to the characters 0x7D, 0x11 and 0x13. Use Table 5 for byte-stuffing.

Original data byte	Transferred data bytes
0x7E	0x7D, 0x5E
0x7D	0x7D, 0x5D
0x11	0x7D, 0x31
0x13	0x7D, 0x33

Table 5 Reference table for byte-stuffing.

Example: Data to send = [0x43, 0x11, 0x7F] → Data transmitted = [0x43, 0x7D, 0x31, 0x7F].

⁹ Sensirion High-Level Data Link Control.

¹⁰ Master Out Slave In. Frame direction from master to slave.

¹¹ Master In Slave Out. Frame direction from slave to master.

Address

The slave device address is always 0.

Command

In the MOSI frame the command tells the device what to do with the transmitted data. In the MISO frame, the slave just returns the received command.

Length

Length of the “TX Data” or “RX Data” field (before byte-stuffing).

State

The MISO frame contains a state byte, which allows the master to detect communication and execution errors. The first bit is reserved for future use. Figure 7 shows the composition of the Status byte.

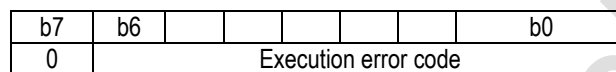

Figure 7 Status byte structure.

The execution error code signalizes all errors which occur while processing the frame or executing the command. The following table shows the error codes which can be reported from the device. Note that some of these errors are system internal errors which require additional knowledge to be understood. In case of a problem, they will help Sensirion to localize and solve the issue.

Error Code		Meaning
dec	hex	
0	0x00	No error
1	0x01	Wrong data length for this command (too much or little data)
2	0x02	Unknown command
3	0x03	No access right for command
4	0x04	Illegal command parameter or parameter out of allowed range
40	0x28	Internal function argument out of range
67	0x43	Command not allowed in current state

Table 6 Reference table for error codes.

Data

The data has a usable size of [0...255] bytes (original data, before byte-stuffing). The meaning of the data content depends on the command.

Checksum

The checksum is built before byte-stuffing and checked after removing stuffed bytes from the frame. The checksum is defined as follows:

1. Sum all bytes between start and stop (without start and stop bytes).
2. Take the LSB of the result and invert it. This will be the checksum.

For a MOSI frame use Address, Command, Length and Data to calculate the checksum.

For a MISO frame use Address, Command, State, Length and Data to calculate the checksum.

Example (MOSI frame without start/stop and without byte-stuffing):

Adr	CMD	L	Tx Data 2 Bytes	CHK
0x00	0x00	0x02	0x01, 0x03	0xF9

The checksum is calculated as follows:

Adr	0x00
CMD	0x00
L	0x02
Data 0	0x01
Data 1	0x03
Sum	0x06
LSB of Sum	0x06
Inverted (=Checksum)	0xF9

4.2 UART / SHDLIC Commands

The following table shows an overview of the available SHDLIC commands.

CMD	Command	Read / Write / Execute
0x00	Start Measurement	Execute
0x01	Stop Measurement	Execute
0x03	Read Measured Value	Read
0x80	Read/Write Auto Cleaning Interval	Read / Write
0x56	Start Fan Cleaning	Execute
0xD0	Device Information	Read
0xD3	Reset	Execute

Table 7 Reference table for SHDLIC commands.

4.2.1 Start Measurement (CMD: 0x00)

Starts the measurement¹². After power up, the module is in Idle-Mode. Before any measurement values can be read, the Measurement-Mode needs to be started using this command.

MOSI Data:

Byte #	Datatype	Description
0	uint8	Subcommand, this value must be set to 0x01
1	uint8	Measurement-Mode, this value must be set to 0x03

MISO Data:

No data.

Example Frames:

MOSI	0x7E 0x00 0x00 0x02 0x01 0x03 0xF9 0x7E
MISO	Empty response frame: 0x7E 0x00 0x00 0x00 0x00 0xFF 0x7E

¹² This command can only be executed in Idle-Mode.

4.2.2 Stop Measurement (CMD: 0x01)

Stops the measurement¹³. Use this command to return to the initial state (Idle-Mode).

MOSI Data:

No data.

MISO Data:

No data.

Example Frames:

MOSI	0x7E 0x00 0x01 0x00 0xFE 0x7E
MISO	0x7E 0x00 0x01 0x00 0x00 0xFE 0x7E

4.2.3 Read Measured Values (CMD: 0x03)

Reads the measured values from the module. This command can be used to poll for new measurement values. If no new measurements are available, the module returns an empty response frame. The default measurement interval is 1 second.

MOSI Data:

No data.

MISO Data:

If no new measurement values are available: no data.

If new measurement values are available:

Byte #	Datatype	Description
0..3	float (IEEE754)	Mass Concentration PM1.0 [$\mu\text{g}/\text{m}^3$]
4..7	float (IEEE754)	Mass Concentration PM2.5 [$\mu\text{g}/\text{m}^3$]
8..11	float (IEEE754)	Mass Concentration PM4.0 [$\mu\text{g}/\text{m}^3$]
12..15	float (IEEE754)	Mass Concentration PM10 [$\mu\text{g}/\text{m}^3$]
16..19	float (IEEE754)	Number Concentration PM0.5 [$\#/ \text{cm}^3$]
20..23	float (IEEE754)	Number Concentration PM1.0 [$\#/ \text{cm}^3$]
24..27	float (IEEE754)	Number Concentration PM2.5 [$\#/ \text{cm}^3$]
28..31	float (IEEE754)	Number Concentration PM4.0 [$\#/ \text{cm}^3$]
32..35	float (IEEE754)	Number Concentration PM10 [$\#/ \text{cm}^3$]
36..39	float (IEEE754)	Typical Particle Size [μm]

Example Frames:

MOSI	0x7E 0x00 0x03 0x00 0xFC 0x7E
MISO	Empty response frame: 0x7E 0x00 0x03 0x00 0x00 0xFC 0x7E
	Or response frame with new measurement values: 0x7E 0x00 0x03 0x00 0x28 0x00 0xD4 0x7E

¹³ This command can only be executed in Measurement-Mode.

4.2.4 Read/Write Auto Cleaning Interval (CMD: 0x80)

Reads/Writes the interval [s] of the periodic fan-cleaning. When the module is in Measurement-Mode an automatic fan-cleaning procedure will be triggered periodically following a defined cleaning interval. This will accelerate the fan to maximum speed for 10 seconds in order to blow out the dust accumulated inside the fan.

Important notes:

- Measurement values are not updated while the fan-cleaning is running.
- Set the interval to 0 to disable the automatic cleaning.
- Once set, the interval is stored permanently in the non-volatile memory.
- The default cleaning interval is set to 604'800 seconds (i.e., 168 hours or 1 week).
- If the sensor is switched off, the time counter is reset to 0. Make sure to trigger a cleaning cycle at least every week if the sensor is switched off and on periodically (e.g., once per day).

MOSI Data:

Read Auto Cleaning Interval:

Byte #	Datatype	Description
0	uint32	Subcommand, this value must be set to 0x00

Write Auto Cleaning Interval:

Byte #	Datatype	Description
0	uint8	Subcommand, this value must be set to 0x00
1..4	uint32	Interval in seconds

MISO Data:

Read Auto Cleaning Interval:

Byte #	Datatype	Description
0..3	uint8	Interval in seconds

Write Auto Cleaning Interval: no data.

Example Frames:

MOSI	Read Auto Cleaning Interval: 0x7E 0x00 0x80 0x01 0x00 0x7D 0x5E 0x7E Write Auto Cleaning Interval to 0 (disable): 0x7E 0x00 0x80 0x05 0x00 0x00 0x00 0x00 0x00 0x7A 0x7E
MISO	Response frame for "Read Auto Cleaning Interval": 0x7E 0x00 0x80 0x00 0x04 0x00 0x00 0x00 0x00 0x7B 0x7E Response frame for "Write Auto Cleaning Interval": 0x7E 0x00 0x80 0x00 0x00 0x7F 0x7E

4.2.5 Start Fan Cleaning (CMD: 0x56)

Starts the fan-cleaning manually¹⁴. For more details, note the explanations given for the "Read/Write Auto Cleaning Interval" command.

MOSI Data:

No data.

¹⁴ This command can only be executed in Measurement-Mode.

Example Frames:

MOSI	0x7E 0x00 0xD3 0x00 0x2C 0x7E
MISO	0x7E 0x00 0xD3 0x00 0x00 0x2C 0x7E

5 Operation and Communication through the I²C Interface

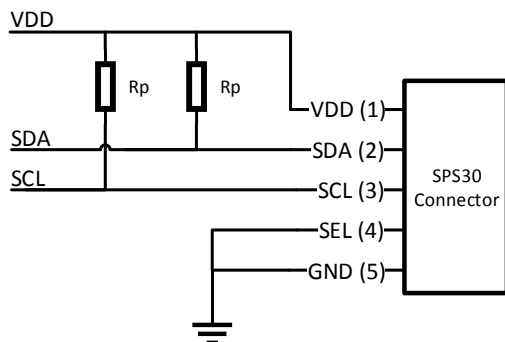

Usage:

- I²C address: 0x69
- Max. speed: standard mode, 100 kbit/s
- Clock stretching: not used

Both SCL and SDA lines are open drain I/Os. They should be connected to external pull-up resistors (e.g. Rp = 10 kΩ). **Important notice:** in order to correctly select I²C as interface, the interface select (SEL) pin must be pulled to GND before or at the same time the sensor is powered up.

Figure 8 Typical I²C application circuit.

Some considerations should be made about the use of the I²C interface. I²C was originally designed to connect two chips on a PCB. When the sensor is connected to the main PCB via a cable, particular attention must be paid to electromagnetic interference and crosstalk. Use as short as possible (< 10 cm) and/or well shielded connection cables. We recommend using the UART interface instead, whenever possible: it is more robust against electromagnetic interference, especially with long connection cables.

5.1 Transfer Types

Set Pointer

Sets the 16-bit address pointer without writing data to the sensor module. It is used to execute commands, which do not require additional parameters.

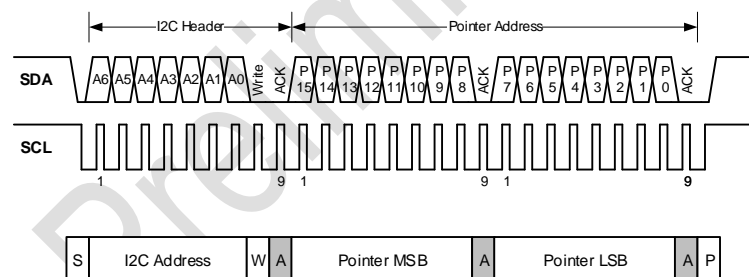

Set Pointer & Read Data

Sets the 16-bit address pointer and read data from sensor module. It is used to read sensor module information or measurement results. The data is ready to read immediately after the address pointer is set. The sensor module transmits the data in 2-byte packets, which are protected with a checksum.

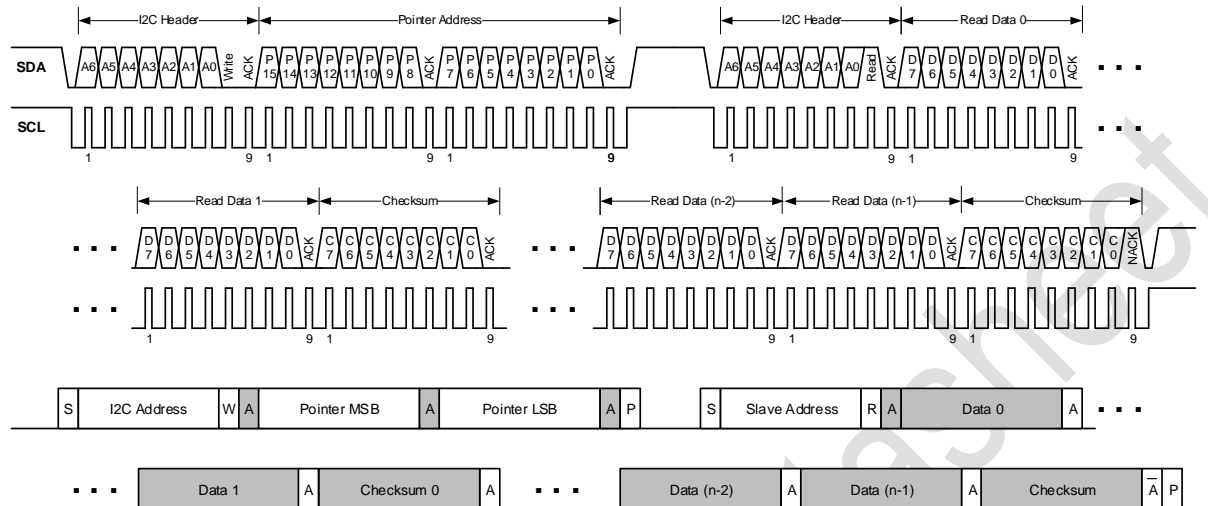

It is allowed to read several times in succession without setting the address pointer again. This reduces the protocol overhead for periodical reading of the measured values.

Set Pointer & Write Data

Sets the 16-bit address pointer and writes data to the sensor module. It is used to execute commands, which require additional parameters. The data must be transmitted in 2-byte packets which are protected by a checksum.

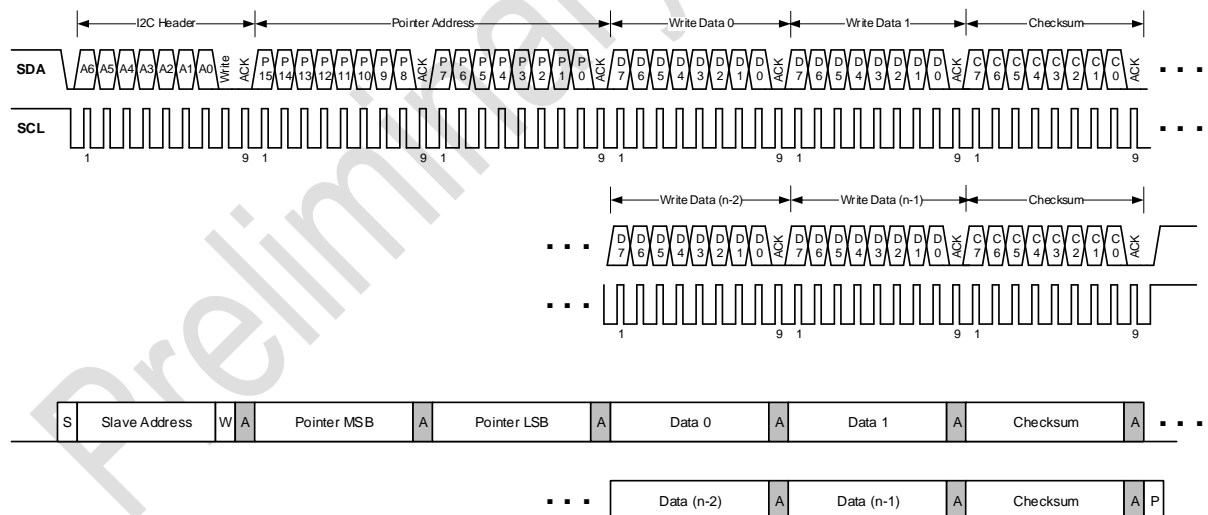

5.2 Checksum Calculation

The Read and Write Commands transmit the data in 2-byte packets, followed by an 8-bit checksum. The checksum is calculated as follows:

Property	Value
Name	CRC-8
Protected Data	read and/or write data
Width	8 bit
Polynomial	0x31 ($x^8 + x^5 + x^4 + 1$)
Initialization	0xFF
Reflect Input	false
Reflect Output	false
Final XOR	0x00
Example	CRC(0xBEEF) = 0x92

```
uint8_t CalcCrc(uint8_t data[2]) {
    uint8_t crc = 0xFF;
    for(int i = 0; i < 2; i++) {
        crc ^= data[i];
        for(uint8_t bit = 8; bit > 0; --bit) {
            if(crc & 0x80) {
                crc = (crc << 1) ^ 0x31;
            } else {
                crc = (crc << 1);
            }
        }
    }
    return crc;
}
```

Please note that the checksums are used only for the 2-byte data packets. The command code itself already contains a 3-bit CRC and therefore no checksum must be appended to it.

5.3 I²C Commands

The following table shows an overview of the available I²C commands.

Address Pointer	Command Name	Transfer Type
0x0010	Start Measurement	Set Pointer & Write Data
0x0104	Stop Measurement	Set Pointer
0x0202	Read Data-Ready Flag	Set Pointer & Read Data
0x0300	Read Measured Values	Set Pointer & Read Data
0x8004	Read/Write Auto Cleaning Interval	Set Pointer & Read/Write Data
0x5607	Start Fan Cleaning	Set Pointer
0xD025	Read Article Code	Set Pointer & Read Data
0xD033	Read Serial Number	Set Pointer & Read Data
0xD304	Reset	Set Pointer

Table 8 Reference table for I²C commands.

5.3.1 Start Measurement (0x0010)

Starts the measurement. After power up, the module is in Idle-Mode. Before any measurement values can be read, the Measurement-Mode needs to be started using this command.

Transfer Type: Set Pointer & Write Data
Pointer Address: 0x0010

Write Data:

Byte #	Description
0	Measurement-Mode, this value must be set to 0x03
1	dummy byte, insert 0x00
2	Checksum for bytes 0, 1

5.3.2 Stop Measurement (0x0104)

Stops the measurement. Use this command to return to the initial state (Idle-Mode).

Transfer Type: Set Pointer
Pointer Address: 0x0104

5.3.3 Read Data-Ready Flag (0x0202)

This command can be used for polling to find out when new measurements are available. The pointer address only has to be set once. Repeated read requests get the status of the Data-Ready Flag.

Transfer Type: Set Pointer & Read Data
Pointer Address: 0x0202

Read Data:

Byte #	Description
0	unused, always 0x00
1	Data-Ready Flag 0x00: no new measurements available 0x01: new measurements ready to read
2	Checksum for bytes 0, 1

5.3.4 Read Measured Values (0x0300)

Reads the measured values from the sensor module and resets the “Data-Ready Flag”. If the sensor module is in Measurement-Mode, an updated measurement value is provided every second and the “Data-Ready Flag” is set. If no synchronized readout is desired, the “Data-Ready Flag” can be ignored. The command “Read Measured Values” always returns the latest measured values.

Transfer Type: Set Pointer & Read Data
Pointer Address: 0x0300

Read Data:

Byte #	Description	
0, 1	Upper two bytes	big-endian, IEEE754 float value: Mass Concentration PM1.0 [µg/m³]
2	Checksum for bytes 0, 1	
3, 4	Lower two bytes	
5	Checksum for bytes 3, 4	
6, 7	Upper two bytes	big-endian, IEEE754 float value: Mass Concentration PM2.5 [µg/m³]
8	Checksum for bytes 6, 7	
9, 10	Lower two bytes	
11	Checksum for bytes 9, 10	
12, 13	Upper two bytes	big-endian, IEEE754 float value: Mass Concentration PM4.0 [µg/m³]
14	Checksum for bytes 12, 13	
15, 16	Lower two bytes	
17	Checksum for bytes 15, 16	
18, 19	Upper two bytes	big-endian, IEEE754 float value: Mass Concentration PM10 [µg/m³]
20	Checksum for bytes 18, 19	
21, 22	Lower two bytes	
23	Checksum for bytes 21, 22	

24, 25	Upper two bytes	big-endian, IEEE754 float value: Number Concentration PM0.5 [#/cm³]
26	Checksum for bytes 24, 25	
27, 28	Lower two bytes	
29	Checksum for bytes 27, 28	
30, 31	Upper two bytes	big-endian, IEEE754 float value: Number Concentration PM1.0 [#/cm³]
32	Checksum for bytes 30, 31	
33, 34	Lower two bytes	
35	Checksum for bytes 33, 34	
36, 37	Upper two bytes	big-endian, IEEE754 float value: Number Concentration PM2.5 [#/cm³]
38	Checksum for bytes 36, 37	
39, 40	Lower two bytes	
41	Checksum for bytes 39, 40	
42, 43	Upper two bytes	big-endian, IEEE754 float value: Number Concentration PM4.0 [#/cm³]
44	Checksum for bytes 42, 43	
45, 46	Lower two bytes	
47	Checksum for bytes 45, 46	
48, 49	Upper two bytes	big-endian, IEEE754 float value: Number Concentration PM10 [#/cm³]
50	Checksum for bytes 48, 49	
51, 52	Lower two bytes	
53	Checksum for bytes 51, 52	
54, 55	Upper two bytes	big-endian, IEEE754 float value: Typical Particle Size [µm]
56	Checksum for bytes 54, 55	
57, 58	Lower two bytes	
59	Checksum for bytes 57, 58	

5.3.5 Read/Write Auto Cleaning Interval (0x8004)

Reads/Writes the interval [s] of the periodic fan-cleaning. When the module is in Measurement-Mode an automatic fan-cleaning procedure will be triggered periodically following a defined cleaning interval. This will accelerate the fan to maximum speed for 10 seconds in order to blow out the dust accumulated inside the fan.

Note that after writing a new interval, this will be activated immediately. However, if the interval register is read out after setting the new value, the previous value is returned until the next start/reset of the sensor module.

Important notes:

- Measurement values are not updated while the fan-cleaning is running.
- Set the interval to 0 to disable the automatic cleaning.
- Once set, the interval is stored permanently in the non-volatile memory.
- The default cleaning interval is set to 604'800 seconds (i.e., 168 hours or 1 week).
- If the sensor is switched off, the time counter is reset to 0. Make sure to trigger a cleaning cycle at least every week if the sensor is switched off and on periodically (e.g., once per day).

Transfer Type: Set Pointer & Read/Write Data
Pointer Address: 0x8004

Read/Write Data:

Byte #	Description	
0, 1	MSB	big-endian, unsigned 32-bit integer value: Auto Cleaning Interval [s]
2	Checksum for bytes 0, 1	
3, 4	LSB	
5	Checksum for bytes 3, 4	

5.3.6 Start Fan Cleaning (0x5607)

Starts the fan-cleaning manually¹⁵. For more details, note the explanations given for the “Read/Write Auto Cleaning Interval” command.

Transfer Type: Set Pointer
Pointer Address: 0x5607

5.3.7 Read Device Information (0xD025, 0xD033)

This command returns the requested device information. It is defined as a string value with a maximum length of 32 ASCII characters (including terminating null-character).

Transfer Type: Set Pointer & Read Data
Pointer Address: Article Code: 0xD025
Serial Number: 0xD033

Read Data:

Byte #	Description
0	ASCII Character 0
1	ASCII Character 1
2	Checksum for bytes 0, 1
...	...
45	ASCII Character 30
46	ASCII Character 31
47	Checksum for bytes 45, 46

5.3.8 Device Reset (0xD304)

Device software reset command. After calling this command, the module is in the same state as after a power reset.

Transfer Type: Set Pointer
Pointer Address: 0xD304

¹⁵ This command can only be executed in Measurement-Mode.

6 Technical Drawings

6.1 Product Outline Drawings

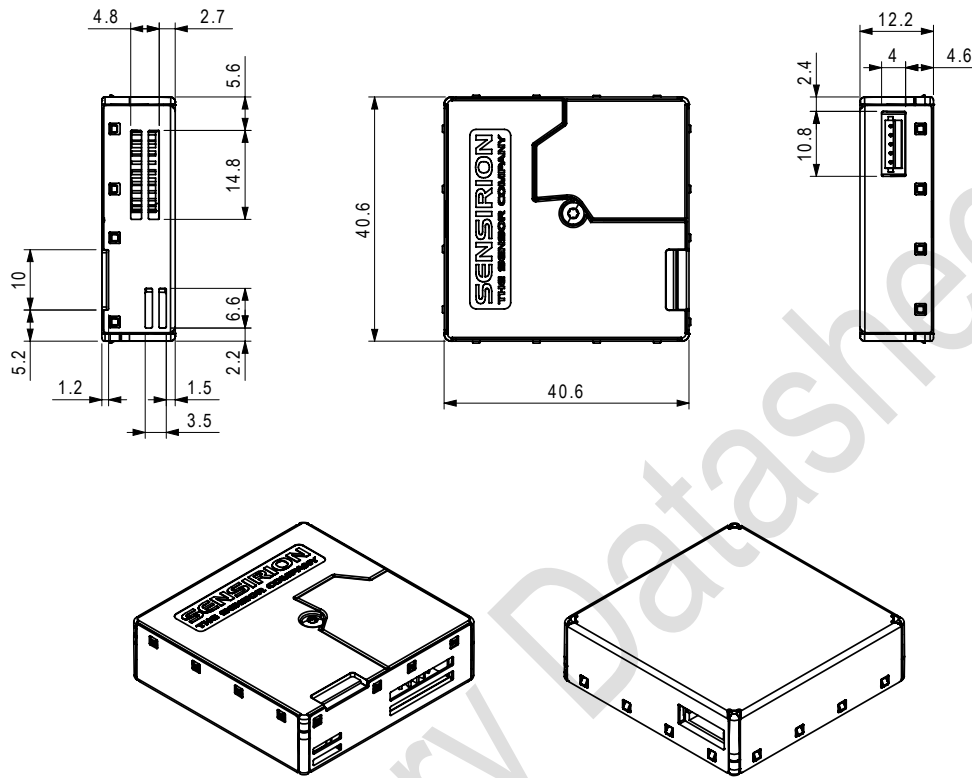

Figure 9: Package outline dimensions (in mm) of the SPS30.

7 Shipping Package

The SPS30 is shipped in stackable trays with 56 pieces each. Non-packaged tray dimensions are given in Figure 10. Packaged tray dimensions are 670 mm x 460 mm x 45 mm. The weight of each full packaged tray (including sensors) is 2.4 kg.

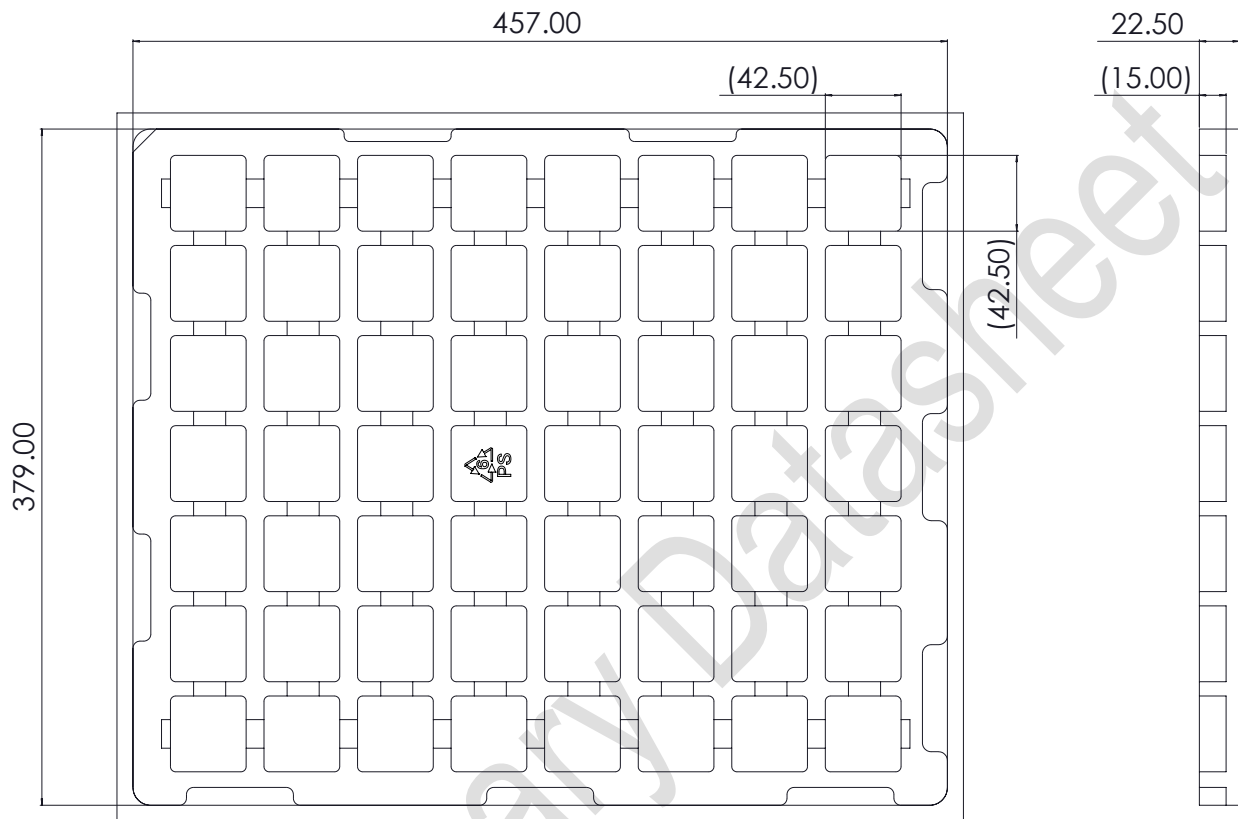

Figure 10: 56-sensor tray dimensions (in mm).

8 Ordering Information

The SPS30 and its evaluation kit can be ordered via the article numbers listed in Table 9.

Product	Description	Article Number
SPS30 sensor	Particulate Matter Sensor	1-101638-10
SPS30 evaluation kit	SPS30 sensor and USB evaluation kit	3.000.119

Table 9: SPS30 and evaluation kit ordering information.

9 Important Notices

9.1 Warning, Personal Injury

Do not use this product as safety or emergency stop devices or in any other application where failure of the product could result in personal injury. Do not use this product for applications other than its intended and authorized use. Before installing, handling, using or servicing this product, please consult the data sheet and application notes. Failure to comply with these instructions could result in death or serious injury.

If the Buyer shall purchase or use SENSIRION products for any unintended or unauthorized application, Buyer shall defend, indemnify and hold harmless SENSIRION and its officers, employees, subsidiaries, affiliates and distributors against all claims, costs, damages and expenses, and reasonable attorney fees arising out of, directly or indirectly, any claim of personal injury or death associated with such unintended or unauthorized use, even if SENSIRION shall be allegedly negligent with respect to the design or the manufacture of the product.

9.2 ESD Precautions

The inherent design of this component causes it to be sensitive to electrostatic discharge (ESD). To prevent ESD-induced damage and/or degradation, take customary and statutory ESD precautions when handling this product. See application note "ESD, Latchup and EMC" for more information.

9.3 Warranty

SENSIRION warrants solely to the original purchaser of this product for a period of 12 months (one year) from the date of delivery that this product shall be of the quality, material and workmanship defined in SENSIRION's published specifications of the product. Within such period, if proven to be defective, SENSIRION shall repair and/or replace this product, in SENSIRION's discretion, free of charge to the Buyer, provided that:

- notice in writing describing the defects shall be given to SENSIRION within fourteen (14) days after their appearance;
- such defects shall be found, to SENSIRION's reasonable satisfaction, to have arisen from SENSIRION's faulty design, material, or workmanship;
- the defective product shall be returned to SENSIRION's factory at the Buyer's expense; and
- the warranty period for any repaired or replaced product shall be limited to the unexpired portion of the original period.

This warranty does not apply to any equipment which has not been installed and used within the specifications recommended by SENSIRION for the intended and proper use of the equipment. EXCEPT FOR THE WARRANTIES EXPRESSLY SET FORTH HEREIN, SENSIRION MAKES NO WARRANTIES, EITHER EXPRESS OR IMPLIED, WITH RESPECT TO THE PRODUCT. ANY AND ALL WARRANTIES, INCLUDING WITHOUT LIMITATION, WARRANTIES OF MERCHANTABILITY OR FITNESS FOR A PARTICULAR PURPOSE, ARE EXPRESSLY EXCLUDED AND DECLINED.

SENSIRION is only liable for defects of this product arising under the conditions of operation provided for in the data sheet and proper use of the goods. SENSIRION explicitly disclaims all warranties, express or implied, for any period during which the goods are operated or stored not in accordance with the technical specifications.

SENSIRION does not assume any liability arising out of any application or use of any product or circuit and specifically disclaims any and all liability, including without limitation consequential or incidental damages. All operating parameters, including without limitation recommended parameters, must be validated for each customer's applications by customer's technical experts. Recommended parameters can and do vary in different applications.

SENSIRION reserves the right, without further notice, (i) to change the product specifications and/or the information in this document and (ii) to improve reliability, functions and design of this product.

Copyright© 2018, by SENSIRION.
CMOSens® is a trademark of Sensirion
All rights reserved

10 Headquarters and Subsidiaries

Sensirion AG

Laubisruetistr. 50
CH-8712 Staefa ZH
Switzerland

phone: +41 44 306 40 00
fax: +41 44 306 40 30

info@sensirion.com
www.sensirion.com

Sensirion Taiwan Co. Ltd

phone: +886 3 5506701

info@sensirion.com
www.sensirion.com

Sensirion Inc., USA

phone: +1 312 690 5858

info-us@sensirion.com
www.sensirion.com

Sensirion Japan Co. Ltd.

phone: +81 3 3444 4940

info-jp@sensirion.com
www.sensirion.co.jp

Sensirion Korea Co. Ltd.

phone: +82 31 337 7700~3

info-kr@sensirion.com
www.sensirion.co.kr

Sensirion China Co. Ltd.

phone: +86 755 8252 1501

info-cn@sensirion.com
www.sensirion.com.cn

To find your local representative, please visit www.sensirion.com/distributors

Компания «Life Electronics» занимается поставками электронных компонентов импортного и отечественного производства от производителей и со складов крупных дистрибьюторов Европы, Америки и Азии.

С конца 2013 года компания активно расширяет линейку поставок компонентов по направлению коаксиальный кабель, кварцевые генераторы и конденсаторы (керамические, пленочные, электролитические), за счёт заключения дистрибьюторских договоров

Мы предлагаем:

- Конкурентоспособные цены и скидки постоянным клиентам.
- Специальные условия для постоянных клиентов.
- Подбор аналогов.
- Поставку компонентов в любых объемах, удовлетворяющих вашим потребностям.
- Приемлемые сроки поставки, возможна ускоренная поставка.
- Доставку товара в любую точку России и стран СНГ.
- Комплексную поставку.
- Работу по проектам и поставку образцов.
- Формирование склада под заказчика.
- Сертификаты соответствия на поставляемую продукцию (по желанию клиента).
- Тестирование поставляемой продукции.
- Поставку компонентов, требующих военную и космическую приемку.
- Входной контроль качества.
- Наличие сертификата ISO.

В составе нашей компании организован Конструкторский отдел, призванный помогать разработчикам, и инженерам.

Конструкторский отдел помогает осуществить:

- Регистрацию проекта у производителя компонентов.
- Техническую поддержку проекта.
- Защиту от снятия компонента с производства.
- Оценку стоимости проекта по компонентам.
- Изготовление тестовой платы монтаж и пусконаладочные работы.



Тел: +7 (812) 336 43 04 (многоканальный)

Email: org@lifeelectronics.ru